

ATTENTION:
 GENERAL MANAGER
 PARTS MANAGER
 CLAIMS PERSONNEL
 SERVICE MANAGER

IMPORTANT - All Service Personnel Should Read and Initial in the boxes provided, right.

© 2019 Subaru of America, Inc. All rights reserved.



QUALITY DRIVEN® SERVICE

SERVICE BULLETIN

APPLICABILITY: 2019MY Forester

NUMBER: 12-262-19

SUBJECT: Hood Release Cable -Design Change

DATE: 10/02/19

INTRODUCTION:

This bulletin announces availability of a new hood lock release cable to address concerns of the front hood lock not releasing when the release lever is pulled. The new inner cable diameter has been increased and the shape of the cable end has been changed to improve engagement between the release cable end and the lock release mechanism. Latching of the hood is not affected by this change.

PRODUCTION CHANGE INFORMATION:

This bulletin will be updated with the production change information when it becomes available.

PART INFORMATION:

REMINDER: Always order the most up-to-date replacement parts based on the specific VIN being repaired.

The part number for the new style CABLE-FRONT HOOD is **57330SJ011**.

- Comparison Illustrations between the New and Old-Style cables:

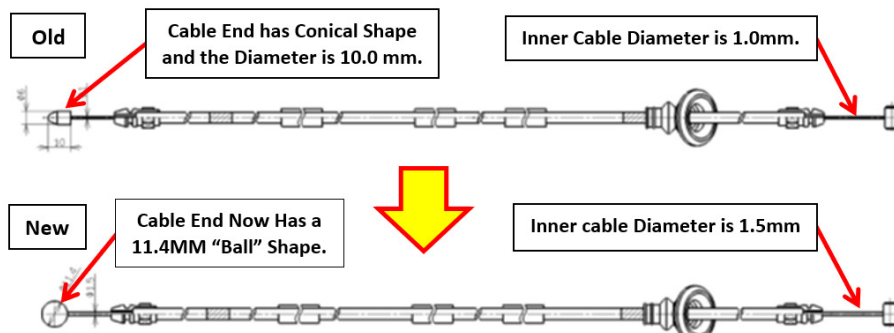

CAUTION: VEHICLE SERVICING PERFORMED BY UNTRAINED PERSONS COULD RESULT IN SERIOUS INJURY TO THOSE PERSONS OR TO OTHERS.

Subaru Service Bulletins are intended for use by professional technicians ONLY. They are written to inform those technicians of conditions that may occur in some vehicles, or to provide information that could assist in the proper servicing of the vehicle. Properly trained technicians have the equipment, tools, safety instructions, and know-how to do the job correctly and safely. If a condition is described, DO NOT assume that this Service Bulletin applies to your vehicle, or that your vehicle will have that condition.

Subaru of America, Inc. is ISO 14001 Compliant

ISO 14001 is the international standard for excellence in Environmental Management Systems. Please recycle or dispose of automotive products in a manner that is friendly to our environment and in accordance with all local, state and federal laws and regulations.

Continued...

SERVICE PROCEDURE / INFORMATION:

REMINDER: Customer satisfaction and retention starts with performing quality repairs.

The service procedure replacing the hood release cable is basically unchanged although an additional inspection and steps have been added when installing the New Style part. Always refer to the applicable Service Manual and review the full requirements of the repair being performed. The Service Manual procedures contain information critical to performing an effective repair the first time and every time. This includes but is not limited to: important SAFETY precautions, proper inspection criteria, necessary special tools, required processes and related one-time-use parts needed for a complete and lasting repair.

Step 1) Release the hood lock and remove the Bracket- Grill Lower (9 clips) and the hood lock (latch) assembly following the procedures in the applicable Service Manual.

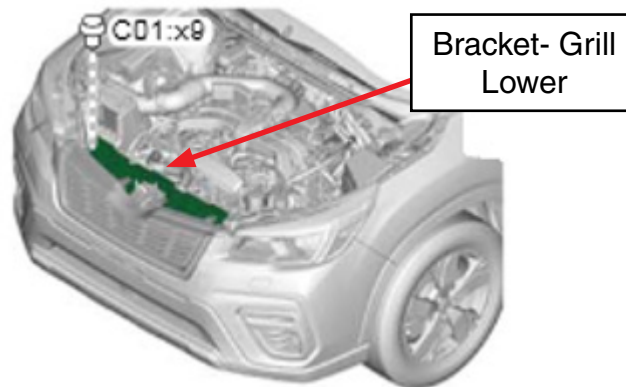

Step 2) Inspect the hood lock closely for the rubber buffer shown in the photos below. Fig. 1 shows a buffer with a long projection while the buffer's projection shown in Fig. 2 is very short.

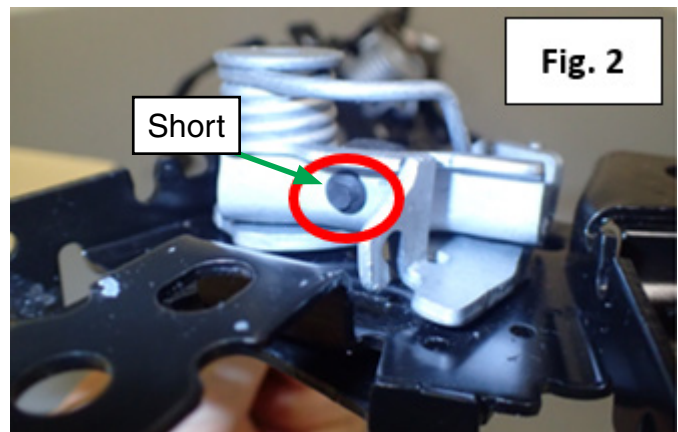
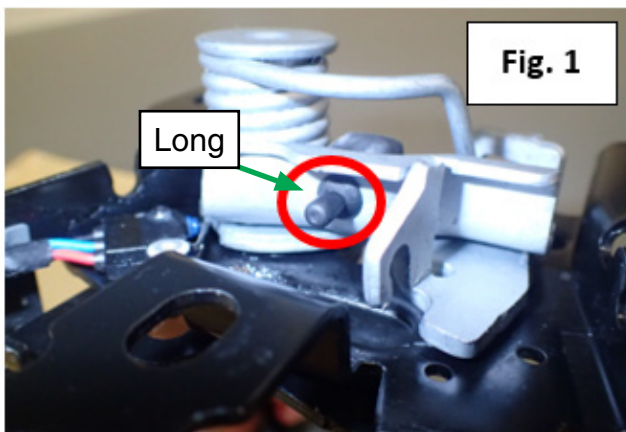

Continued...

Step 3)

- If inspection reveals a hood lock with a “long” projection buffer as shown in Fig. 1 above, 4mm from the end of the projection must be trimmed off using a small wire cutter or equivalent. Use the illustration below as a guideline.

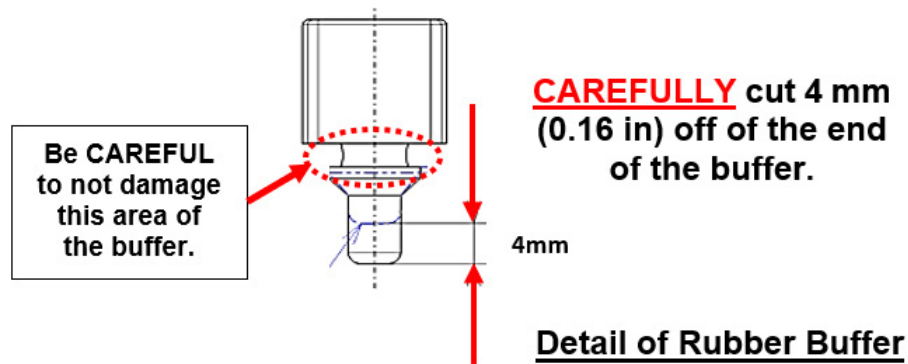

- If the buffer has a short projection as shown in Fig. 2 above, proceed to Step 4.

Step 4) Install the new hood cable assembly following the procedure in the applicable Service Manual.

Step 5) Reinstall all removed components in reverse order of removal. Confirm proper operation of the hood lock and release cable mechanism to complete the procedure.

WARRANTY / CLAIM INFORMATION:

For vehicles within the Basic New Car Limited Warranty period or covered by an active Subaru Added Security Gold plan, this repair may be submitted using the following claim information:

Labor Description	Labor Operation #	Labor Time	Fail Code
HOOD RELEASE CABLE R&R	A915-101	0.5	SBP-29

IMPORTANT REMINDERS:

- SOA strongly discourages the printing and/or local storage of service information as previously released information and electronic publications may be updated at any time.
- Always check for any open recalls or campaigns anytime a vehicle is in for servicing.
- Always refer to STIS for the latest service information before performing any repairs.