

> Constellation  
> Heritage  
> 4700 Models

> 4800 Models  
> 4900 Models  
> 5700 Models

> 5900 Models  
> 6900 Models

**Western Star  
Service Bulletin**

**Description of Revisions:** *This bulletin replaces the version dated August 2015. Instructions for proper visual inspection distance have been added under the Important Information heading.*

## Important Information

The following information addresses the assessment of blemishes and repairs in Western Star vehicles' paint finish. These standards, which outline requirements for paint-finish quality and blemish repairs, are used by Western Star personnel to ensure consistency and quality, in paint finishes on all vehicles.

## Tools

Tools used to measure paint finish can be expensive. However, Axalta (formerly DuPont) and PPG distributors and field representatives have paint-finish measuring tools and the knowledge to use them. Contact Axalta (formerly DuPont) and PPG personnel for assistance and tools through your Daimler Trucks North America (DTNA) Field Service Representative.

## Visual Inspection Distance

All paint inspections must be performed at a distance of approximately 3 feet (1 meter) from the vehicle. The light intensity in the inspection area must meet a minimum of 100 foot-candles (1076 meter-candles).

## Warranty

Repairs made to correct paint defects **WILL NOT** be paid under warranty, unless the defect violates these paint finish standards. Since determination whether a paint defect violates the paint finish standards is subjective, DTNA Field Service or Warranty Department representatives should be consulted before questionable paint repairs are undertaken. Requirements and procedures for filing paint claims are outlined in the Warranty Manual.

**NOTE:** Certain areas of the vehicle either are not painted, or are not painted to a standard. Therefore, claims for repairing the paint on these surfaces are not warrantable. The areas include:

- The underside of the hood, including the inside of the wheel wells;
- the underside of the roof-mounted air fairing;
- the underside of the exterior sun visor;
- the inside of the side-mounted air fairings;
- the inside of the bumper.

## Quality Assurance Appearance Requirements

These standards describe the painted surface appearance requirements for a vehicle cab and chassis to meet the quality expected in a Western Star vehicle.

## Appearance Zones

All vehicles are divided into various appearance zones, with specific requirements for each zone. See [Fig. 1](#), and [Table 1](#).

Appearance quality requirements are detailed in "Quality Requirements for Appearance Attributes — Cab and Hood."

Standards for appearance are detailed in "Paint Surface Blemishes."

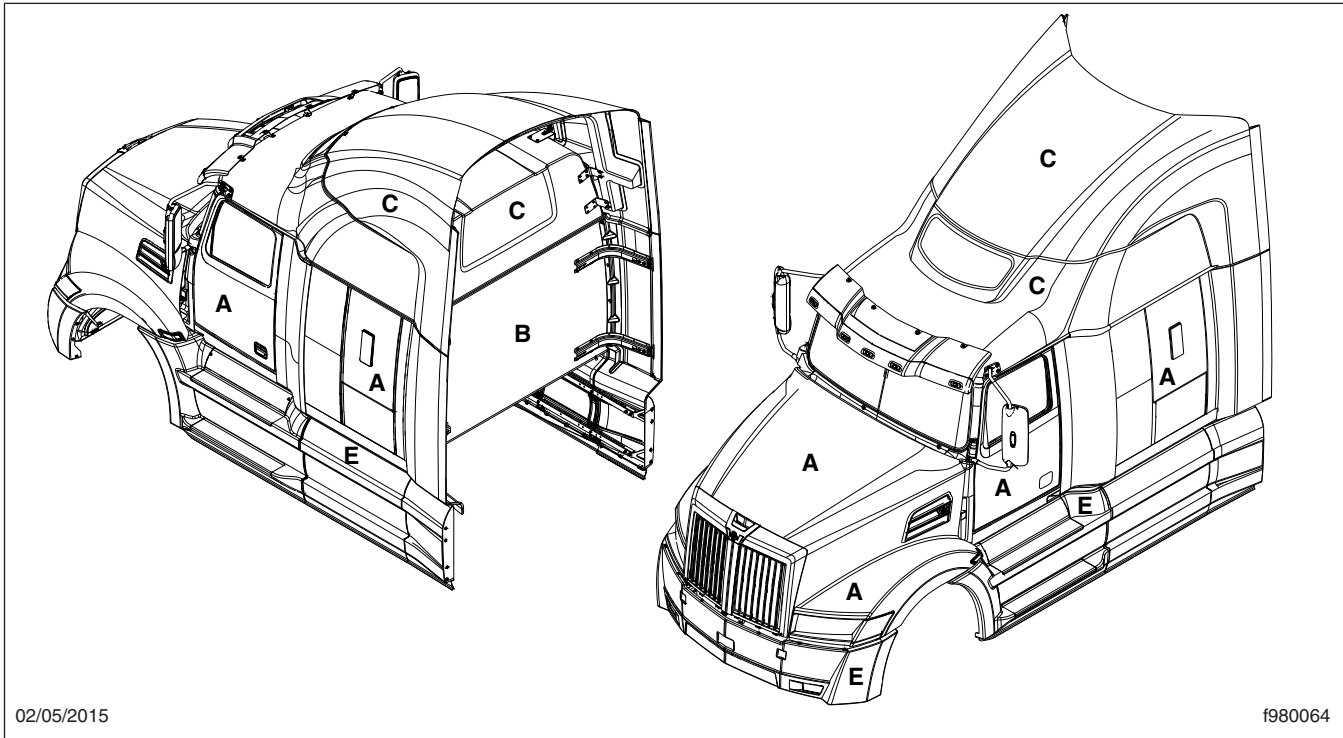

02/05/2015

f980064

**Fig. 1, Paint Appearance Zones (Typical)**

Zone	Description
	<b>All Exterior Surfaces of the Cab, except the Back Panel and Roof Sections:</b>
A	Passenger, Baggage, and Access Doors (including exterior visible surfaces when door is closed), A-Pillar, Cab and Sleeper Side, B-Pillar, Cowl Side, Lower Skirting, Cab Interior, Hood Top and Sides, Cowl Top, Fender, Upper and Lower Nose Skin, Center Nose Skin, Headlight Bucket, Sun Visor, Chassis Side Fairing, Forward Quarter-Fender, Bumper, and Side Extenders (outboard side only)
B	Back of Cab Panel, Raised Roof Side, Mid-Roof Side, Raised Roof Back Panel and Raised Roof below Skylight, Side Extenders (inboard side only), and Trim Tabs
C	Flat Roof, Mid-Roof Top, Raised Roof Cap Above Skylight, Interior Surfaces of Passenger, Baggage, and Access Doors; "B" Side Surfaces (underside or inside) of Fairing Fuel Door, Sun Visor, and Roof Fairing
D	Chassis and Chassis Components
E	Molded plastic proprietary textured surface parts such as some Chassis Side Fairing and Bumper options

**Table 1, Appearance Zones of a Cab and Hood**

NOTE: The interior surfaces of the hood and fender wells are to have a light coating (fog) of topcoat paint; however, there are no appearance or surface blemish standard requirements for these areas.

> Constellation  
> Heritage  
> 4700 Models

> 4800 Models  
> 4900 Models  
> 5700 Models

> 5900 Models  
> 6900 Models

## Quality Requirements for Appearance Attributes—Cab and Hood Gloss

**Condition:** The term used to describe the relative amount of mirror-like reflection. This is measured in the percentage of light reflected from the surface.

**Method of Inspection:** Gloss is measured using a 20-degree gloss meter. Gloss measurements should be taken only on flat surfaces of the cab. Contoured surfaces, such as those on the hood, will give false readings. Do not take gloss measurements on the chassis, as the surface preparation of the frame rails is uneven.

**Measurement Required:** Measure three random points on each of the following surfaces:

- left-hand door
- left-hand sleeper side
- right-hand door
- right-hand sleeper side

Record the average of each set of the above measurements.

**Appearance Zone Requirements:** These requirements include Imron 5000 and Imron 6000 Basecoat/Clearcoat. See [Table 2](#).

20-Degree Gloss		
Zone	Non-Metallic	Metallic
A	80	65
B	N/A	N/A
C	N/A	N/A
D	N/A	N/A
E*	80	65

\* A 60-degree gloss meter is used for zone E. If a 60-degree meter is not available, a 20-degree meter may be used, however the resulting gloss measurement will show a 30 point difference of the value measured in zone A.

**Table 2, 20-Degree Gloss**

## Orange Peel

**Condition:** An evenly textured surface appearance similar to the skin of an orange.

**Method of Inspection:** Instrumental evaluation with wave scan or visual evaluation and comparison with the standard ACT orange peel panels ranging from 1 (worst) to 10 (best). When evaluating orange peel, measure a minimum of three random points on each of the following surfaces:

- left-hand door
- left-hand sleeper side
- right-hand door
- right-hand sleeper side

Record the average of each set of the above measurements.

**Appearance Zone Requirements:** See [Table 3](#).

Orange Peel	
Zone	Requirement
A	≥5
B	N/A
C	N/A
D	N/A
E	N/A

**Table 3, Orange Peel**

## Uniformity

Uniformity refers to the consistency of the topcoat appearance over the entire vehicle. Gloss, orange peel, and color should not be visibly different within individual body panels or between adjacent panels in a zone. For example, the gloss of a zone A panel will match other zone A panels, and the gloss of a zone E panel will match other zone E panels.

## Film Thickness

Film thickness refers to the layer depth of dry paint on the surface of the part after the baking process.

**Method of Inspection:** Film thickness can be evaluated instrumentally with a mil thickness gauge suitable for the substrate material. Film thickness measurements are taken as a combination of primer and topcoat for a total thickness.

When evaluating film thickness by instrumental means, measure a minimum of three random points on each of the following surfaces:

- left-hand door
- left-hand sleeper side
- right-hand door
- right-hand sleeper side

Record the average of each set of the above measurements.

**Appearance Zone Requirements:** See [Table 4](#).

Paint Film Thickness		
Zone	Single Stage	Base/Clear Coat
A	2.8 mils	3.4 mils
B	N/A	N/A
C	N/A	N/A
D	2.4 mils	N/A
E	2.8 mils	3.4 mils

**Table 4, Paint Film Thickness**

## Paint Surface Blemishes

When combinations of the following blemishes are present, apply the standards for the highest quality requirement.

> Constellation  
> Heritage  
> 4700 Models

> 4800 Models  
> 4900 Models  
> 5700 Models

> 5900 Models  
> 6900 Models

## Bubbles/Craters

**Condition:** Small, round depressions in the paint film that may, or may not expose the underlying surface.

**Method of Inspection:** Visual inspection only.

**Appearance Zone Requirements:** See [Table 5](#).

Bubbles/Craters				
Zone	Quantity Per Panel Per Zone	Maximum Size (diameter)	Minimum Distance Apart	Description
A	5 maximum	2 mm	2 allowed within a 6-inch (150-mm) diameter circle	Primer not exposed
B	Unlimited	2 mm	10 allowed within a 6-inch (150-mm) diameter circle	Primer not exposed
C	Unlimited	3 mm	N/A	Primer not exposed
D	Unlimited	4 mm	N/A	Primer not exposed
E	5 maximum	2 mm	2 allowed within a 6-inch (150-mm) diameter circle	Primer not exposed

**Table 5, Bubbles/Craters**

## Dirt

**Condition:** Foreign matter in, on, or under the paint film surface (e.g., lint, fibers, sanding dust, etc.).

**Method of Inspection:** Metric scale with visual evaluation and comparison to boundary samples.

**Appearance Zone Requirements:** See [Table 6](#).

Dirt in Paint			
Zone	Quantity Per Panel Per Zone	Maximum Size (diameter)	Minimum Distance Apart
A	5 maximum	2 mm	2 allowed within a 6-inch (150-mm) diameter circle
B	Unlimited	2 mm	10 allowed within a 6-inch (150-mm) diameter circle
C	Unlimited	3 mm	No requirement
D	N/A	N/A	N/A
E	5 maximum	2 mm	2 allowed within a 6-inch (150-mm) diameter circle

**Table 6, Dirt in Paint**

## Ding/Dent

**Condition:** A ding/dent is a visible depression or protrusion in the metal surface or substrate.

**Method of Inspection:** Visual evaluation and comparison with appearance zone requirements.

**Appearance Zone Requirements:** See [Table 7](#).

Ding/Dent	
Zone	Quantity per Panel
A	0 maximum
B	0 maximum
C	No requirement
D	N/A

Ding/Dent	
Zone	Quantity per Panel
E	N/A

**Table 7, Ding/Dent**

## Overspray

**Condition:** Overspray is a rough or gritty texture on a painted surface caused by small droplets of paint that fail to blend or melt into the surface.

**Method of Inspection:** Visual evaluation and comparison with appearance zone requirements; color difference is not acceptable.

**Appearance Zone Requirements:** See [Table 8](#).

Overspray	
Zone	Quantity per Panel
A	No visible or felt overspray
B	No visible or felt overspray
C	No visible overspray allowed
D	No overspray of a different color allowed
E	No visible or felt overspray

**Table 8, Overspray**

## Solvent Pops

**Condition:** Small holes in a paint film usually caused by trapped solvent. Solvent boils are small, clustered, raised but unbroken bubbles in a paint film surface.

**Method of Inspection:** Visual evaluation and comparison with appearance zone requirements.

**Appearance Zone Requirements:** See [Table 9](#).

Solvent Pop			
Zone	Quantity per Panel	Maximum Size	Description
A	Unlimited	0.5 mm	3 areas allowed per panel No area larger than 6-inch (150-mm) diameter circle
B	Unlimited	0.5 mm	10 areas allowed per panel No area larger than 6-inch (150-mm) diameter circle
C	Unlimited	0.5 mm	N/A
D	Unlimited	0.5 mm	N/A
E	Unlimited	0.5 mm	3 areas allowed per panel No area larger than 6-inch (150-mm) diameter circle

**Table 9, Solvent Pop**

> Constellation  
> Heritage  
> 4700 Models

> 4800 Models  
> 4900 Models  
> 5700 Models

> 5900 Models  
> 6900 Models

## Polishing Marks

**Condition:** Marks left by polishing are identified as visible swirl or hazy marks.

**Method of Inspection:** Visual evaluation.

**Requirements:** See [Table 10](#).

Polishing Marks	
Zone	Quantity per Panel
A	None allowed
B	None allowed
C	N/A
D	N/A
E	None allowed

**Table 10, Polishing Marks**

## Sags and Runs

**Condition:** Non-uniform downward flow of a wet paint film, typically found around rivets and along edges.

**Method of Inspection:** Visual evaluation and comparison to examples shown in [Table 11](#).

**Appearance Zone Requirements:** See [Table 11](#).

Sags and Runs		
Zone	Quantity per Panel	Maximum Size
A	3	4 mm vertical; no color change
B	10	4 mm vertical
C	Allowed	4 mm vertical
D	Allowed	Outside frame rail: 2 inches (50 mm) Inside frame rail: 6 inches (150 mm)
E	3	4 mm vertical; no color change

**Table 11, Sags and Runs**

## Scratches and Mars

**Condition:** Scratched or marred paint surface.

**Method of Inspection:** Visual evaluation and comparison with appearance zone requirements.

**Appearance Zone Requirements:** See [Table 12](#).

Scratches and Mars			
Zone	Allowed	Maximum Size (length)	Description
A	Yes	25 mm	Visible but not felt; easily polished out
B	Yes	25 mm	Visible and felt
C	Unlimited	No requirement	No bare substrate primer exposed

Scratches and Mars			
Zone	Allowed	Maximum Size (length)	Description
D	Unlimited	No requirement	No bare substrate primer exposed
E	Yes	25 mm	Visible and felt

**Table 12, Scratches and Mars**

## File/Grind Marks

**Condition:** Cuts in the surface metal caused by poor file technique or incorrect repair (visible after paint).

**Method of Inspection:** Visual evaluation and comparison with appearance zone requirements.

**Appearance Zone Requirements:** See [Table 13](#).

File and Grind Marks	
Zone	Quantity per Panel
A	None allowed
B	None allowed
C	N/A
D	N/A
E	None allowed

**Table 13, File and Grind Marks**

## Pinholes

**Condition:** Small holes in a paint film, usually in the area of a silicon bronze joint, on plastic parts, or polyester body fill (i.e., porosity).

**Method of Inspection:** Visual evaluation and comparison with appearance zone requirements.

**Appearance Zone Requirements:** See [Table 14](#).

Pinholes			
Zone	Quantity Per Panel Per Zone	Maximum Size (diameter)	Description
A	5 maximum	2 mm	2 allowed within a 6-inch (150-mm) diameter circle
B	Unlimited	2 mm	10 allowed within a 6-inch (150-mm) diameter circle
C	Unlimited	3 mm	No requirement
D	N/A	N/A	N/A
E	5 maximum	2 mm	2 allowed within a 6-inch (150-mm) diameter circle

**Table 14, Pinholes**

## Paint Chips

**Condition:** The absence of a small portion of the paint film usually caused by scraping or impacting the painted surface. Rock chips are a common example.

**Method of Inspection:** Visual evaluation and comparison with appearance zone requirements.

> Constellation  
> Heritage  
> 4700 Models

> 4800 Models  
> 4900 Models  
> 5700 Models

> 5900 Models  
> 6900 Models

**Appearance Zone Requirements:** See [Table 15](#).

Paint Chips	
Zone	Quantity per Panel
A	None allowed
B	None allowed
C	No bare substrate or primer exposed
D	No bare substrate or primer exposed
E	None allowed

**Table 15, Paint Chips**

## Stripes and Paint Break Edges

**Condition:** The chipping or loss of adhesion of small portions of the paint film from the edge of the stripe or paint break.

**Definition:** A stripe is any color less than 8 inches (203 mm) wide. A paint break is wider than 8 inches (203 mm).

**Method of Inspection:** Visual evaluation and comparison with appearance zone requirements.

**Appearance Zone Requirements:** See [Table 16](#).

Stripes and Paint Breaks		
Zone	Allowed	Description
A	Yes	Very slight loss of edge (less than 2 mm)
B	Yes	5 mm horizontal: 1 mm vertical: Must be at least 11-3/4 inches (300 mm) away from next occurrence
C	Yes	5 mm horizontal: 1 mm vertical: Must be at least 11-3/4 inches (300 mm) away from next occurrence
D	N/A	N/A
E	Yes	Very slight loss of edge (less than 2 mm)

**Table 16, Stripes and Paint Breaks**

## Chassis Paint Requirements

The chassis is inspected for runs and sags, overspray, grind marks, inadequate paint coverage, and loss of adhesion (primer and/or topcoat) at the time of manufacture.

**NOTE:** Chassis includes frame rails, crossmembers, axles, drivelines, battery boxes, fuel tanks, and wheels.

## Chassis Marks

Cosmetic surface marks and scratches are usually present on the frame rails. These surface marks are acceptable, as long as they are properly covered with paint.

## Western Star Service Bulletin

> Constellation  
> Heritage  
> 4700 Models

> 4800 Models  
> 4900 Models  
> 5700 Models

> 5900 Models  
> 6900 Models

## Sags and Runs

**Outside:** Sags or runs on the outside of the rail or in visible areas of brackets, axle, hubs, or wheels shall be allowed, if no longer than 2 inches (50 mm) in length and have only a single crest. All other runs are unacceptable.

**Inside:** Sags or runs inside the rail and in less visible areas are allowed, if no longer than 6 inches (150 mm) in length. All other runs are unacceptable, including runs on drivelines, crossmembers, etc.

## Overspray

Overspray on visible areas of bumpers, steps, battery and tool boxes, brackets, axles, hubs, wheels, drivelines, or frame rails is unacceptable. Overspray inside the frame rail is allowed, if it is not an unacceptable color.

## Inadequate Paint Coverage

Inadequate or incomplete primer/substrate paint coverage, visible or hidden, is unacceptable and requires touch-up.

**IMPORTANT:** Several vehicle components, such as aluminum wheel hubs, are not meant to be painted.

## Loss of Adhesion

Loss of adhesion to primer and/or topcoat on any visible or hidden areas of the chassis is unacceptable.

## Tape Test

In instances where it is difficult to determine an adhesion problem, a tape test should be performed using the following steps.

1. Photograph an area that **does not** already have paint damage.
2. Take a piece of regular masking tape and press it firmly to the area.
3. Pull (jerk) the tape off quickly.
4. Photograph any paint attached to the tape.
5. Photograph any paint missing from where the tape was applied.
6. Large parts will need to have multiple areas tested.

**IMPORTANT:** A second option is the cross-hatch method where a small "X" is scribed with a razor blade through the paint and primer prior to performing the tape test. However, if no adhesion problem is found, fixing the scribe "X" damage will be the **responsibility of the person performing the tape test**.

## Topcoat Requirement

The chassis topcoat thickness (plus primer) requirement is to be 2.4±0.5 mils using Axalta's (formerly DuPont's) Imron 5000 or the Standard Black Urethane.

The chassis topcoat thickness (plus primer) requirement is to be 2.5±0.5 mils using PPG Delfleet Evolution®.

**NOTE:** Chassis paint finish gloss cannot be measured with a meter, because of the uneven metal surface condition.

> Constellation  
> Heritage  
> 4700 Models

> 4800 Models  
> 4900 Models  
> 5700 Models

> 5900 Models  
> 6900 Models

**Western Star  
Service Bulletin**

## Warranty

This is an informational bulletin only; warranty does not apply.