



# Service Bulletin

Bulletin No.: 19-NA-222

Date: September, 2019

## TECHNICAL

**Subject:** Upper B-Pillar Rattle Noise

Brand:	Model:	Model Year:		VIN:		Engine:	Transmission:
		from	to	from	to		
Cadillac	XT4	2019	2020			All	All

<b>Involved Region or Country</b>	North America, Middle East, Palestine, Europe, Russia
<b>Condition</b>	Some customers may comment on hearing a slight B-Pillar rattle noise on the driver and/or passenger side of the vehicle.
<b>Cause</b>	The cause of the condition may be an unintended design variance which may allow too much clearance between the center pillar upper trim panel and the seatbelt retractor D-ring and belt.
<b>Correction</b>	Verify if one, or both, B-Pillar(s) are affected and follow the steps in the Service Procedure below to eliminate the condition.

### Service Procedure

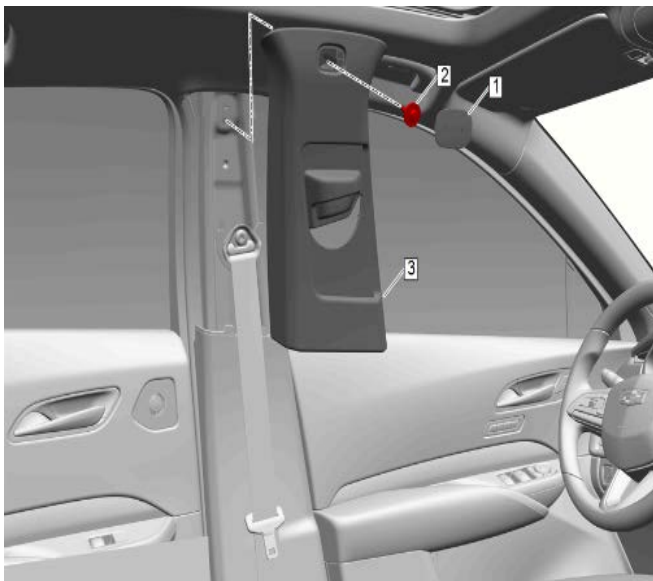

5411087

1. Remove the center pillar upper trim panel (3) on the affected side. Refer to *Center Pillar Upper Trim Panel Replacement* in SI.

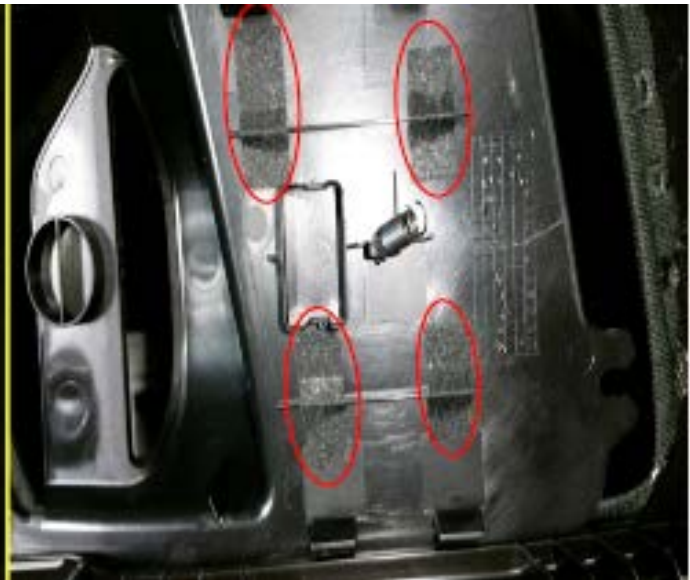

5411089

**Note:** The trim panel may need more than one tape piece applied per location. Use your best judgement as to what final thickness of tape will help alleviate the clearance issue.

2. Once the panel is removed, add Kent Automotive BRS Tape P/N KT13486, or equivalent, to the four areas shown in the graphic above.

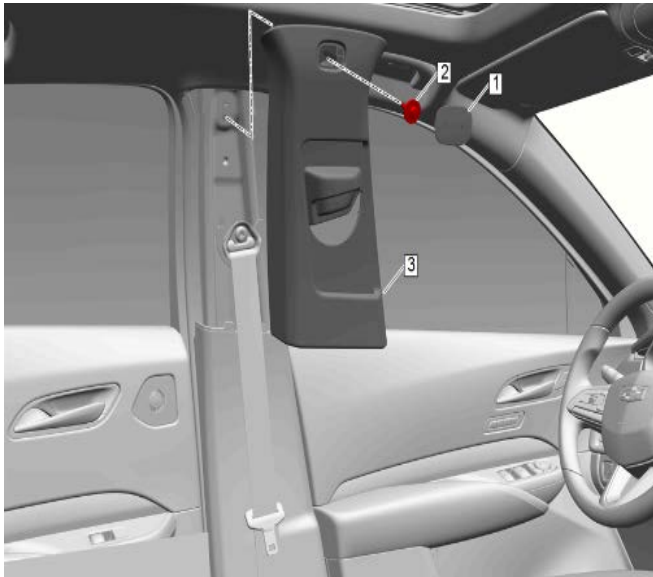

5411087

3. Reinstall the center pillar upper trim panel (3). Refer to *Center Pillar Upper Trim Panel Replacement* in SI.

4. If affected, repeat steps 1–3 on the opposite side.
5. After reassembly, test drive the vehicle to verify that the rattle noise condition has been eliminated.

**Parts Information**

Contact Kent Automotive at 1-888-YES-KENT or online at [www.kent-automotive.com](http://www.kent-automotive.com).

Causal Part	Description	Part Number	Material Allowance
N/A	Kent Automotive BRS Tape	KT13486	\$ 2.20 U.S. \$2.92 Canada

**Warranty Information**

For vehicles repaired under the Bumper-to-Bumper coverage (Canada Base Warranty coverage), use the following labor operation. Reference the Applicable Warranties section of Investigate Vehicle History (IVH) for coverage information.

Labor Operation	Description	Labor Time
1086108*	Remove and Reinstall Center Pillar Upper Trim, Add BRS Tape (Inc. Test drive)	0.6 hr
Add	Same Repair Opposite Side	0.3 hr

\*This is a unique Labor Operation for Bulletin use only.

<b>Version</b>	1
<b>Modified</b>	Released September 24, 2019

GM bulletins are intended for use by professional technicians, NOT a "do-it-yourselfer". They are written to inform these technicians of conditions that may occur on some vehicles, or to provide information that could assist in the proper service of a vehicle. Properly trained technicians have the equipment, tools, safety instructions, and know-how to do a job properly and safely. If a condition is described, DO NOT assume that the bulletin applies to your vehicle, or that your vehicle will have that condition. See your GM dealer for information on whether your vehicle may benefit from the information.



WE SUPPORT VOLUNTARY  
TECHNICIAN  
CERTIFICATION