

**TECHNICAL INSTRUCTIONS  
FOR  
CUSTOMER SUPPORT PROGRAM ZKA**

\*\*\*\*\*

**CERTAIN 2011 THROUGH 2015 MODEL YEAR TACOMA**

\*\*\*\*\*

**COVERAGE FOR VEHICLE FRAME CORROSION PERFORATION**

The repair quality of covered vehicles is extremely important to Toyota. All dealership technicians performing this CSP are required to successfully complete the most current version of the E-Learning course "Safety Recall and Service Campaign Essentials". To ensure that all vehicles have the repair performed correctly; technicians performing this repair are required to currently hold at least one of the following certification levels:

- Certified Technician (any specialty)
- Expert Technician (any specialty)
- Master Technician
- Master Diagnostic Technician

Final repair must be signed off and validated by a MDT, Shop Foreman or Service Manager using the Frame Replacement Inspection Form.

It is the dealership's responsibility to select technicians with the above certification level or greater to perform this CSP repair. Carefully review your resources, the technician skill level, and ability before assigning technicians to this repair. It is important to consider technician days off and vacation schedules to ensure there are properly trained technicians available to perform this repair at all times.

# I. OPERATION FLOWCHART

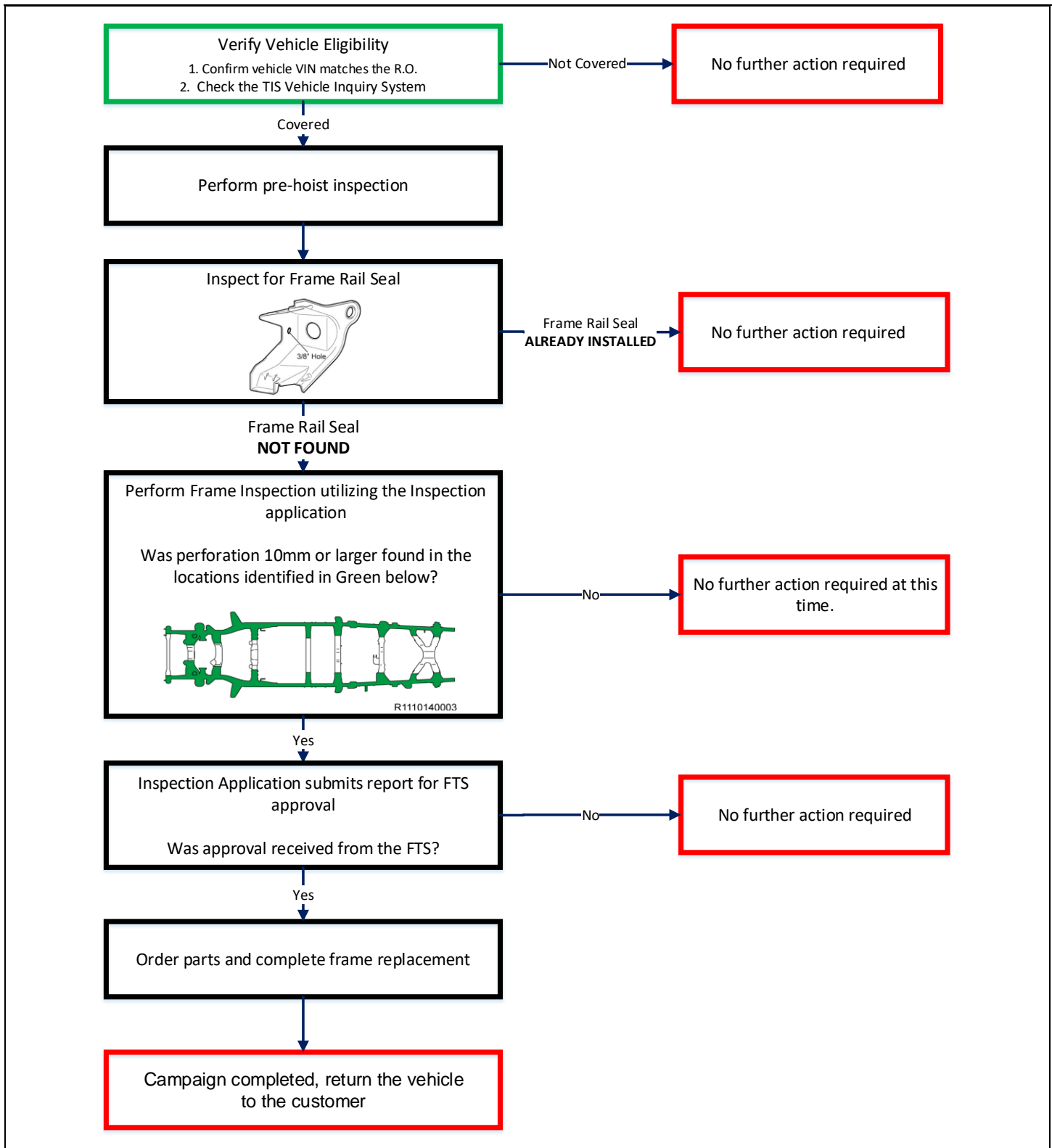

**Cold Climate States Include - CT, DE, IL, IN, KY, MA, MD, ME, MI, MN, NH, NJ, NY, OH, PA, RI, VA, VT, WI, WV and District of Columbia**

## Background

Toyota has received a number of reports regarding vehicle frame corrosion perforation on certain 2011-2017 model year Tacoma vehicles. These reports have indicated that these vehicles, when operated in specific cold climate areas (Cold Climate States<sup>1</sup>) with high road salt usage, or exposed to other environmental factors, may exhibit more-than-normal corrosion to the vehicle's frame.

## II. PREPARATION

### A. TOOLS & EQUIPMENT

- A/C service equipment
- Alignment rack
- Brake bleeder
- Engine hanger
  - 1GR-FE Engine
    - 12281-31060 – Engine hanger No. 1 (Qty: 1)
    - 12282-31040 – Engine hanger No. 2 (Qty: 1)
    - 90119-08A87 – Bolt (Qty: 4)
  - 2TR-FE Engine
    - 12281-75050 – Engine hanger (Qty: 2)
    - 91672-81025 – Bolt (Qty: 2)
- Engine hoist (Qty: 2) or Hydraulic mini crane (Qty 2)
- Engine sling (Qty: 2)
- Protective eyewear
- Protective gloves
- Ratcheting tie down strap (2 in X 27 ft, minimum work load capacity: 3,000 lbs)
- Special Service Tools (SST)
  - 09325-40010 – Transmission oil plug (*Transmission A340E*)
  - 09610-20012 – Pitman arm puller (*2WD*)
  - 09628-62011 – Ball joint puller (*4WD, Pre-Runner*)
  - 09520-32040 – A component of SST 09520-24010, Differential side gear shaft puller
  - 09520-01010 – Drive shaft remover attachment
  - 09628-00011 – Ball joint puller
  - 09922-10010-01 – Variable open wrench
- Standard hand tools
- Techstream
- Torque wrench
- Torx® T55H socket
- Socket wrench 35mm
- Hexagon wrench 8, 10
- Deep socket wrench 10, 12, 14, 17, 19mm
- Union Nut Wrench 10mm
- Weights

### B. SUPPLIES

- Toyota Genuine ATF WS or DEXRON® III (DEXRON® II) – As needed
- Hypoid gear oil API GL-5 SAE 75W-90 – 1.5 liter (*4WD Only*)
- R134a refrigerant – As needed
- Toyota DOT 3 brake fluid – 3 pints
- Toyota long life coolant – 2 gallons
- Paint Marker
- MP Grease

**THE PARTS SHOWN BELOW WERE INCLUDED IN ZH6 2005-2010MY FRAME REPLACEMENT PARTS BUT WILL NOT BE INCLUDED IN ZKA 2011-2015**



- **When removing the reusable parts, be careful to NOT damage and make them non-reusable.**

Judge if the following parts are reusable or not on the actual vehicle, and order the part individually as needed.

## Reusable Parts for 2011-2015MY

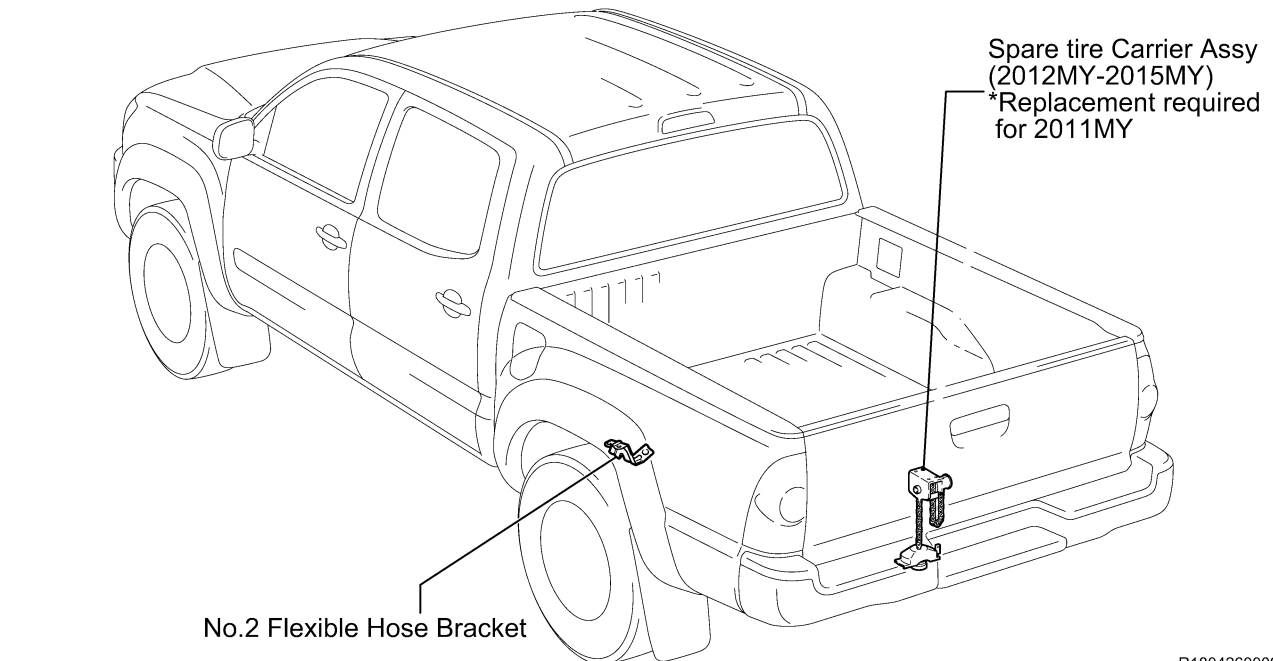
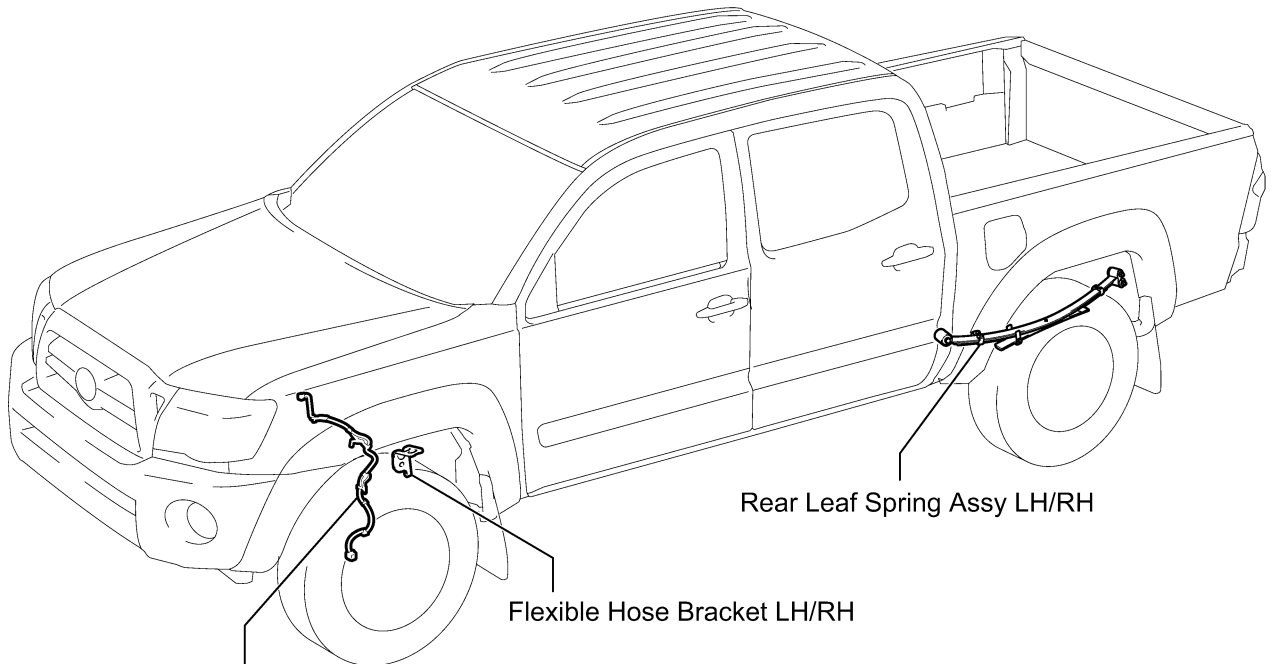

R1804260009

## C. PARTS

To assist dealers in determining the correct part number(s) to order, a website has been set up to look up part numbers by VIN. Please go to <https://tacoma-2011-2017-frames.imagespm.info/> select the appropriate campaign/vehicle, enter the VIN, and the correct part numbers to order will be displayed. **The website is for part(s) application reference only and won't order the parts, confirm campaign completion status, or confirm campaign applicability.**

- The parts will need to be ordered through the Dealer Daily Parts System.
- ETAs for the parts will be available via the normal system.
- Frame ETAs will be made available on the Dealer Daily website, in the MAC reference area.

**Note: When first logging in; enter your dealer code and the default password; xxxxx. Upon logging in the website will ask for you to reset the password and provide an email address.**

An illustration of the parts replaced and their location(s) have been provided. Please reference the "**Illustration Name**" and "**Page**" columns in the parts tables below.

### Individual Parts:

Part Number	Part Description	Quantity	Illustration Name	Page
04006-63304	(GRN225 2011-2012MY)	1	Frame	13
04008-15104	(GRN225 2013-2015MY)	1	Frame	13
04006-63704	(GRN245 DCB 2011-2012MY)	1	Frame	13
04008-15204	(GRN245 DCB 2013-2015MY)	1	Frame	13
04006-63604	(GRN245 LCB 2011-2012MY)	1	Frame	13
04008-15304	(GRN245 LCB 2013-2015MY)	1	Frame	13
04006-64504	(GRN250 2011-2012MY)	1	Frame	13
04008-15404	(GRN250 2013-2015MY)	1	Frame	13
04006-64304	(GRN265 DCB 2011-2012MY)	1	Frame	13
04008-15504	(GRN265 DCB 2013-2015MY)	1	Frame	13
04006-64104	(GRN265 LCB 2011-2012MY)	1	Frame	13
04008-15604	(GRN265 LCB 2013-2015MY)	1	Frame	13
04006-64404	(GRN270 2011-2012MY)	1	Frame	13
04008-15704	(GRN270 2013-2015MY)	1	Frame	13
04006-63104	(TRN220 2011-2012MY)	1	Frame	13
04008-16504	(TRN220 2013-2014MY)	1	Frame	13
04008-16604	(TRN225 DCB 2011-2012MY)	1	Frame	13
04008-16704	(TRN225 DCB 2013-2015MY)	1	Frame	13
04006-63204	(TRN225 LCB 2011-2012MY)	1	Frame	13
04008-16804	(TRN225 LCB 2013-2015MY)	1	Frame	13
04008-16904	(TRN240 4AT 2011-2012MY)	1	Frame	13
04008-17104	(TRN240 4AT 2013-2014MY)	1	Frame	13
04006-63404	(TRN240 5MT 2011-2012MY)	1	Frame	13
04008-17204	(TRN240 5MT 2013-2014MY)	1	Frame	13
04008-17404	(TRN245 4AT 2011-2012MY)	1	Frame	13
04008-17504	(TRN245 4AT 2013-2015MY)	1	Frame	13
04006-63504	(TRN245 5MT 2011-2012MY)	1	Frame	13
04008-17604	(TRN245 5MT 2013-2015MY)	1	Frame	13
04008-17804	(TRN265 DCB 2011-2012MY)	1	Frame	13
04008-17904	(TRN265 DCB 2013-2015MY)	1	Frame	13
04008-18204	(TRN265 LCB 2011-2012MY)	1	Frame	13
04008-18304	(TRN265 LCB 2013-2015MY)	1	Frame	13

**Individual Parts (Continued):**

<b>Part Number</b>	<b>Part Description</b>	<b>Quantity</b>	<b>Illustration Name</b>	<b>Page</b>
43425-04040	Ring, Shaft Snap (For Front Drive Inner Shaft Outer)	2	Front Suspension	15
47313-04210	Tube, Front Brake, No.3	1	Brake Tubes	17,18,20
47313-04241	Tube, Front Brake, No.3	1	Brake Tubes	17,18,20
47315-04180	Tube, Front Brake, No.5	1	Brake Tubes	17,18,20
47315-04191	Tube, Front Brake, No.5	1	Brake Tubes	17,18,20
47323-04180	Tube, Rear Brake, No.3	1	Brake Tubes	17,18,20
47323-04191	Tube, Rear Brake, No.3	1	Brake Tubes	17,18,20
47324-04140	Tube, Rear Brake, No.4	1	Brake Tubes	17,18,20
47324-04151	Tube, Rear Brake, No.4	1	Brake Tubes	17,18,20
47325-04190	Tube, Rear Brake, No.5	1	Brake Tubes	17
47325-04191	Tube, Rear Brake, No.5	1	Brake Tubes	17
47325-04200	Tube, Rear Brake, No.5	1	Brake Tubes	18-21
47325-04201	Tube, Rear Brake, No.5	1	Brake Tubes	18-21
47325-04210	Tube, Rear Brake, No.5	1	Brake Tubes	20
47325-04211	Tube, Rear Brake, No.5	1	Brake Tubes	20
47326-04160	Tube, Rear Brake, No.6	1	Brake Tubes	17
47326-04161	Tube, Rear Brake, No.6	1	Brake Tubes	17
47326-04170	Tube, Rear Brake, No.6	1	Brake Tubes	18-21
47326-04171	Tube, Rear Brake, No.6	1	Brake Tubes	18-21
47326-04180	Tube, Rear Brake, No.6	1	Brake Tubes	20
47326-04181	Tube, Rear Brake, No.6	1	Brake Tubes	20
48068-04030	Arm Sub-Assy, Front Suspension, Lower No.1 RH	1	Front Suspension	14
48068-04040	Arm Sub-Assy, Front Suspension, Lower No.1 RH	1	Front Suspension	15
48069-04030	Arm Sub-Assy, Front Suspension, Lower No.1 LH	1	Front Suspension	14
48069-04040	Arm Sub-Assy, Front Suspension, Lower No.1 LH	1	Front Suspension	15
48304-04090	Bumper, Front Spring, LH	1	Front Suspension	14
48304-04090	Bumper, Front Spring, RH	1	Front Suspension	14
48304-AD010	Bumper, Front Spring, LH	1	Front Suspension	14
48304-AD010	Bumper, Front Spring, RH	1	Front Suspension	14
51900-35410	Carrier Assy, Spare Wheel	1	Spare Tire Carrier	13
51900-35420	Carrier Assy, Spare Wheel	1	Spare Tire Carrier	13
82711-16830	Clamp (For Rear Differential Lock)	1	Wire Harness Brackets	23
82715-04160	Bracket (For 2TR-FE 4WD Front Differential Wire)	1	Wire Harness Brackets	23
82715-04200	Bracket (For 2TR-FE A/F Sensor Wiring)	1	Wire Harness Brackets	23
82715-04200	Bracket (For Frame Wire No.2)	1	Wire Harness Brackets	23
82715-04220	Bracket (For Frame Wire)	1	Wire Harness Brackets	23
82715-04230	Bracket (For Frame Wire)	1	Wire Harness Brackets	23
82715-04240	Bracket (For Frame Wire No.2)	1	Wire Harness Brackets	23
82715-04290	Bracket (For Frame Wire No.2)	1	Wire Harness Brackets	23
82715-04290	Bracket (For 2TR-FE A/F Sensor Wiring)	1	Wire Harness Brackets	23
82715-04350	Bracket (For Frame Wire No.2)	1	Wire Harness Brackets	23
82715-3D680	Bracket (For 1GR-FE 4WD Front Differential Wire)	1	Wire Harness Brackets	23
82715-04250	Bracket (For Rear Differential Lock)	1	Wire Harness Brackets	23
82715-04260	Bracket (For Rear Differential Lock)	1	Wire Harness Brackets	23
90105-A0064	Bolt (For Skid Control Sensor)	1	ABS	23
90105-A0066	Bolt (For Rear Differential Lock)	2	Wire Harness Brackets	23
90119-08A91	Bolt (For Rear Stabilizer Bracket Cover)	4	Rear Suspension	16
90119-A0141	Bolt (For Front Differential Wire Bracket)	1	Wire Harness Brackets	23
90119-A0148	Bolt (For W/ Frame Wire No.2)	2	Wire Harness Brackets	23
90119-A0151	Bolt (For Heat Insulator of Propeller Shaft)	2	Propeller Shaft	25
90119-A0161	Bolt (For Front Stabilizer Bracket)	4	Front Suspension	14
90119-A0169	Bolt (For Brake Tube)	9	Brake Tubes	17-20,22
90119-A0169	Bolt (For 1GR-FE W/O Frame Wire No.2)	2	Wire Harness Brackets	23
90119-A0169	Bolt (For 2TR-FE W/O Frame Wire No.2)	4	Wire Harness Brackets	23
90119-A0169	Bolt (For W/ Frame Wire No.2)	6	Wire Harness Brackets	23
90119-A0193	Bolt (For Front Hook, No.1 W/ Fuel Tank Protector)	2	Under Cover	13
90178-A0001	Nut (For 4WD, Pre-Runner Front Suspension Camber Adjust Cam)	2	Front Suspension	15
90178-A0013	Nut (For 2WD Front Suspension Camber Adjust Cam)	4	Front Suspension	14
90179-08241	Nut (For Fuel Tank Protector)	4	Fuel Tank	22
90240-08054	Pin, W/ Hole (For Transmission Control Rod)	1	Shift Lever	26
90468-14033	Clip (For Transmission Control Rod)	1	Shift Lever	26
90469-A0004	Clamp, Brake Tube, No.11 (For Regular Cab)	2	Brake Tubes	17
90469-A0004	Clamp, Brake Tube, No.11 (For Access Cab)	3	Brake Tubes	18,19
90469-A0004	Clamp, Brake Tube, No.11 (For Double Cab)	4	Brake Tubes	20,21

**Parts Kits:**

Part Number	Part Description	Quantity
04008-07235	Parts Kit No.1 – Common Replacement Kit D	1

**The kit listed above includes the following parts:**

Part Number	Part Description	Qty	Illustration Name	Page
90910-03001	Bolt (For Front Engine Mount)	4	Engine Mounting	24
91671-80814	Bolt (For Rear Engine Mount)	4	Engine Mounting	24
94151-21001	Nut (For Front Engine Mount)	4	Engine Mounting	24
90412-10289	Way (For Front Brake Tube)	2	Brake Tubes	17-21
77285-35760	Clamp, Fuel Tube, No.1	1	Fuel Tubes	22

Part Number	Part Description	Quantity
04008-22104	Parts Kit No.2 – Common Replacement Kit E	1

**The kit listed above includes the following parts:**

Part Number	Part Description	Qty	Illustration Name	Page
90069-08019	Packing (For Radiator Drain Cock)	1	Radiator	26
90080-11555	Bolt (For Steering Intermediate Shaft)	2	Power Steering	24
90412-10276	Way, 2 (For Rear Brake Tube)	1	Brake Tubes	17-21
90949-A1006	Clamp, Brake Tube, No.10	3	Brake Tubes	17-21
90468-A0007	Clip (For Brake Tube)	4	Brake Tubes	17-22
90171-A0005	Nut, Castle (For Front Lower Ball Joint RH)	1	Front Suspension	14,15
90171-A0005	Nut, Castle (For Front Lower Ball Joint LH)	1	Front Suspension	14,15
90080-17215	Nut (For Front Suspension Support)	6	Front Suspension	14,15
90177-A0010	Nut (For Rear Shock Absorber)	2	Rear Suspension	16
90119-A0169	Bolt (For Spare Tire Carrier)	4	Spare Tire Carrier	13
51719-04010	Holder, Body Support Bracket	2	Cab Mounting	13
90178-A0044	Nut (For Front Bumper Extension)	6	Front Bumper	26
90119-A0192	Bolt (For Rear Bumper)	6	Rear Bumper	26
90119-A0249	Bolt (For Fuel Tank Band)	2	Fuel Tank	22
90210-A0002	O Ring (For Discharge Hose Sub-Assy)	1	Air Conditioning	26
90210-A0004	O Ring (For Suction Hose Sub-Assy)	1	Air Conditioning	26

Part Number	Part Description	Quantity
04006-46104	Parts Kit No.3 – JPN Source Parts Kit 4 (4WD)	1

**The kit listed above includes the following parts:**

Part Number	Part Description	Qty	Illustration Name	Page
12157-10010	Gasket, Front Differential Filler Plug	1	Front Differential	24
90430-24003	Gasket, Front Differential Drain Plug	1	Front Differential	24
90311-47027	Seal, Oil (For Differential Side Gear Shaft)	1	Front Differential	24
90311-47026	Seal, Oil (For Differential Side Gear Shaft)	1	Front Differential	24
43514-28010	Cap, Front Axle Hub Grease, RH	1	Front Suspension	15
43514-28010	Cap, Front Axle Hub Grease, LH	1	Front Suspension	15
95381-04045	Cotter Pin (For Front Drive Shaft)	2	Front Suspension	15

**Parts Kits (Continued):**

Part Number	Part Description	Quantity		
04001-71404	Parts Kit No.4 – JPN Source Parts Kit 2 (2WD)	1		
<b>The kit listed above includes the following parts:</b>				
Part Number	Part Description	Qty	Illustration Name	Page
95381-03025	Cotter Pin (For Tie Rod End)	2	Power Steering	24
48190-25010	Cam, Front Suspension Camber Adjust, No.1 RH	2	Front Suspension	14
48190-25010	Cam, Front Suspension Camber Adjust, No.1 LH	2	Front Suspension	14
48198-25010	Cam, Front Suspension Camber Adjust, No.2 RH	2	Front Suspension	14
48198-25010	Cam, Front Suspension Camber Adjust, No.2 LH	2	Front Suspension	14
95381-03230	Cotter Pin (For Front Suspension Lower Arm)	2	Front Suspension	14

Part Number	Part Description	Quantity		
04001-71504	Parts Kit No.5 – JPN Source Parts Kit 3 (4WD and Pre-Runner)	1		
<b>The kit listed above includes the following parts:</b>				
Part Number	Part Description	Qty	Illustration Name	Page
95381-03225	Cotter Pin (For Tie Rod End)	2	Power Steering	24
48190-60020	Cam, Front Suspension Camber Adjust, No.1 RH	1	Front Suspension	15
48190-60020	Cam, Front Suspension Camber Adjust, No.1 LH	1	Front Suspension	15
48198-60011	Cam, Front Suspension Camber Adjust, No.2 RH	1	Front Suspension	15
48198-60011	Cam, Front Suspension Camber Adjust, No.2 LH	1	Front Suspension	15
48409-60020	Cam Sub-Assy, Front Suspension Toe Adjust	2	Front Suspension	15
48452-35020	Plate, Front Suspension Toe Adjust, No.2	2	Front Suspension	15
95381-03230	Cotter Pin (For Front Suspension Lower Arm)	2	Front Suspension	15

Part Number	Part Description	Quantity		
04008-22304	Parts Kit No.6 – USA Source Parts Kit 5 (1GR)	1		
<b>The kit listed above includes the following parts:</b>				
Part Number	Part Description	Qty	Illustration Name	Page
17176-0P030	Gasket, Air Surge Tank to Intake Manifold	1	1GR-FE Exhaust System	25
17451-0D020	Gasket, Exhaust Pipe	1	1GR-FE Exhaust System	25
90080-10291	Bolt (For Exhaust Pipe)	2	1GR-FE Exhaust System	25
90080-11180	Bolt (For Exhaust Pipe Stopper Bracket)	2	1GR-FE Exhaust System	25

Part Number	Part Description	Quantity		
04008-22504	Parts Kit No.7 – USA Source Parts Kit 7 (2TR)	1		
<b>The kit listed above includes the following parts:</b>				
Part Number	Part Description	Qty	Illustration Name	Page
90080-43033	Gasket (Exhaust Pipe)	1	2TR-FE Exhaust System	25
90080-10064	Bolt (Exhaust Pipe)	2	2TR-FE Exhaust System	25
90177-A0004	Nut (Exhaust Pipe)	2	2TR-FE Exhaust System	25



**Parts Kits (Continued):**

<b>Part Number</b>	<b>Part Description</b>	<b>Quantity</b>		
04001-71804	Parts Kit No.8 – USA Source Parts Kit 3 (Except For X-Runner)	1		
<b>The kit listed above includes the following parts:</b>				
<b>Part Number</b>	<b>Part Description</b>	<b>Qty</b>	<b>Illustration Name</b>	<b>Page</b>
90119-A0166	Bolt (For Front Suspension Toe Adjust Cam)	2	Front Suspension	15
48304-04100	Bumper, Front Spring, LH	1	Front Suspension	15
48304-04100	Bumper, Front Spring, RH	1	Front Suspension	15
90119-A0192	Bolt (For Hook No.1)	2	Under Cover	13
90080-11373	Bolt (For Engine Under Cover Sub-Assy No.1)	4	Under Cover	13
90080-11373	Bolt (For Engine Under Cover Sub-Assy No.2)	4	Under Cover	13
90189-A0002	Clip (For Left Rear Wheel Well Liner)	8	Rear Wheel House Liner	26
90189-A0002	Clip (For Quarter Panel Wheel Opening Moulding)	2	Moulding	27
75395-35070	Clip (For Quarter Panel Wheel Opening Moulding)	3	Moulding	27
75396-35020	Clip (For Quarter Panel Wheel Opening Moulding)	7	Moulding	27

<b>Part Number</b>	<b>Part Description</b>	<b>Quantity</b>		
04001-71904	Parts Kit No.9 – USA Source Parts Kit 4 (X-Runner)	1		
<b>The kit listed above includes the following parts:</b>				
<b>Part Number</b>	<b>Part Description</b>	<b>Qty</b>	<b>Illustration Name</b>	<b>Page</b>
90189-A0002	Clip (For Left Rear Wheel Well Liner)	6	Rear Wheel House Liner	26
75395-04010	Clip (For Rocker Panel Moulding)	4	Moulding	27
75396-04010	Clip (For Rocker Panel Moulding)	14	Moulding	27
75395-35070	Clip (For Body Rocker Panel Moulding)	2	Moulding	27
75395-35070	Clip (For Back Door Moulding)	2	Moulding	27
75396-35020	Clip (For Body Rocker Panel Moulding)	1	Moulding	27
75396-35020	Clip (For Back Door Moulding)	1	Moulding	27
90189-A0002	Clip (For Body Rocker Panel Moulding)	1	Moulding	27
90189-A0002	Clip (For Back Door Moulding)	1	Moulding	27

<b>Part Number</b>	<b>Part Description</b>	<b>Quantity</b>		
04001-72204	Parts Kit No.10 – Brake Tube Kit 2 (GRN245 with Off Road Package 2011MY)	1		
<b>The kit listed above includes the following parts:</b>				
<b>Part Number</b>	<b>Part Description</b>	<b>Qty</b>	<b>Illustration Name</b>	<b>Page</b>
47313-04200	Tube, Front Brake, No.3	1	Brake Tubes	19,21
47315-04170	Tube, Front Brake, No.5	1	Brake Tubes	19,21
47323-04170	Tube, Rear Brake, No.3	1	Brake Tubes	19,21
47324-04130	Tube, Rear Brake, No.4	1	Brake Tubes	19,21

**Parts Kits (Continued):**

<b>Part Number</b>	<b>Part Description</b>	<b>Quantity</b>
04008-22704	Prats Kit No.11 – Brake Tube Kit 5 (GRN245 with Off Road or TRD Package 2012-2015MY)	1

**The kit listed above includes the following parts:**

<b>Part Number</b>	<b>Part Description</b>	<b>Qty</b>	<b>Illustration Name</b>	<b>Page</b>
47313-04231	Tube, Front Brake, No.3	1	Brake Tubes	19,21
47315-04171	Tube, Front Brake, No.5	1	Brake Tubes	19,21
47323-04171	Tube, Rear Brake, No.3	1	Brake Tubes	19,21
47324-04131	Tube, Rear Brake, No.4	1	Brake Tubes	19,21

<b>Part Number</b>	<b>Part Description</b>	<b>Quantity</b>
04008-22904	Parts Kit No.12 – Brake Tube Kit 10 (2WD 2011MY)	1

**The kit listed above includes the following parts:**

<b>Part Number</b>	<b>Part Description</b>	<b>Qty</b>	<b>Illustration Name</b>	<b>Page</b>
47314-04140	Tube, Front Brake, No.4	1	Brake Tubes	17,18,20
47316-04140	Tube, Front Brake, No.6	1	Brake Tubes	17,18,20

<b>Part Number</b>	<b>Part Description</b>	<b>Quantity</b>
04008-23104	Parts Kit No.13 – Brake Tube Kit 6 (2WD 2012-2015MY)	1

**The kit listed above includes the following parts:**

<b>Part Number</b>	<b>Part Description</b>	<b>Qty</b>	<b>Illustration Name</b>	<b>Page</b>
47314-04141	Tube, Front Brake, No.4	1	Brake Tubes	17,18,20
47316-04141	Tube, Front Brake, No.6	1	Brake Tubes	17,18,20

<b>Part Number</b>	<b>Part Description</b>	<b>Quantity</b>
04008-23204	Parts Kit No.14 – Brake Tube Kit 11 (4WD and Pre-Runner 2011MY)	1

**The kit listed above includes the following parts:**

<b>Part Number</b>	<b>Part Description</b>	<b>Qty</b>	<b>Illustration Name</b>	<b>Page</b>
47314-04150	Tube, Front Brake, No.4	1	Brake Tubes	17-21
47316-04150	Tube, Front Brake, No.6	1	Brake Tubes	17-21
90119-A0169	Bolt (For Brake Tube)	7	Brake Tubes	17-22

<b>Part Number</b>	<b>Part Description</b>	<b>Quantity</b>
04008-23304	Parts Kit No.15 – Brake Tube Kit 7 (4WD and Pre-Runner 2012-2015MY)	1

**The kit listed above includes the following parts:**

<b>Part Number</b>	<b>Part Description</b>	<b>Qty</b>	<b>Illustration Name</b>	<b>Page</b>
47314-04151	Tube, Front Brake, No.4	1	Brake Tubes	17-21
47316-04151	Tube, Front Brake, No.6	1	Brake Tubes	17-21
90119-A0169	Bolt (For Brake Tube)	7	Brake Tubes	17-22

**Parts Kits (Continued):**

<b>Part Number</b>	<b>Part Description</b>	<b>Quantity</b>
04008-07535	Plug Hole Kit Frame Replacement 1 (4WD and Pre-Runner)	1

**The kit listed above includes the following parts:**

<b>Part Number</b>	<b>Part Description</b>	<b>Qty</b>	<b>Illustration Name</b>	<b>Page</b>
90333-20001	Plug, Plate	10	N/A	N/A
90333-30002	Plug, Plate	29	N/A	N/A
90950-01631	Plug, Hole	4	N/A	N/A
90950-01931	Plug, Hole	1	N/A	N/A
90950-01983	Plug, Hole	4	N/A	N/A
90950-01984	Plug, Hole	2	N/A	N/A
90950-01987	Plug, Hole	8	N/A	N/A
90950-01989	Plug, Hole	4	N/A	N/A
90950-01990	Plug, Hole	4	N/A	N/A
90950-01991	Plug, Hole	4	N/A	N/A
90950-01992	Plug, Hole	2	N/A	N/A
90950-01A24	Plug, Hole	2	N/A	N/A

<b>Part Number</b>	<b>Part Description</b>	<b>Quantity</b>
04007-18235	Plug Hole Kit (2WD)	1

**The kit listed above includes the following parts:**

<b>Part Number</b>	<b>Part Description</b>	<b>Qty</b>	<b>Illustration Name</b>	<b>Page</b>
90333-20001	Plug, Plate	2	N/A	N/A
90333-30002	Plug, Plate	36	N/A	N/A
90950-01631	Plug, Hole	4	N/A	N/A
90950-01931	Plug, Hole	1	N/A	N/A
90950-01983	Plug, Hole	4	N/A	N/A
90950-01984	Plug, Hole	2	N/A	N/A
90950-01987	Plug, Hole	6	N/A	N/A
90950-01989	Plug, Hole	4	N/A	N/A
90950-01990	Plug, Hole	4	N/A	N/A
90950-01991	Plug, Hole	4	N/A	N/A
90950-01992	Plug, Hole	2	N/A	N/A
90950-01A09	Plug, Hole	2	N/A	N/A
90950-01A11	Plug, Hole	2	N/A	N/A
90950-01A24	Plug, Hole	2	N/A	N/A

## D. PARTS ILLUSTRATION

### Frame

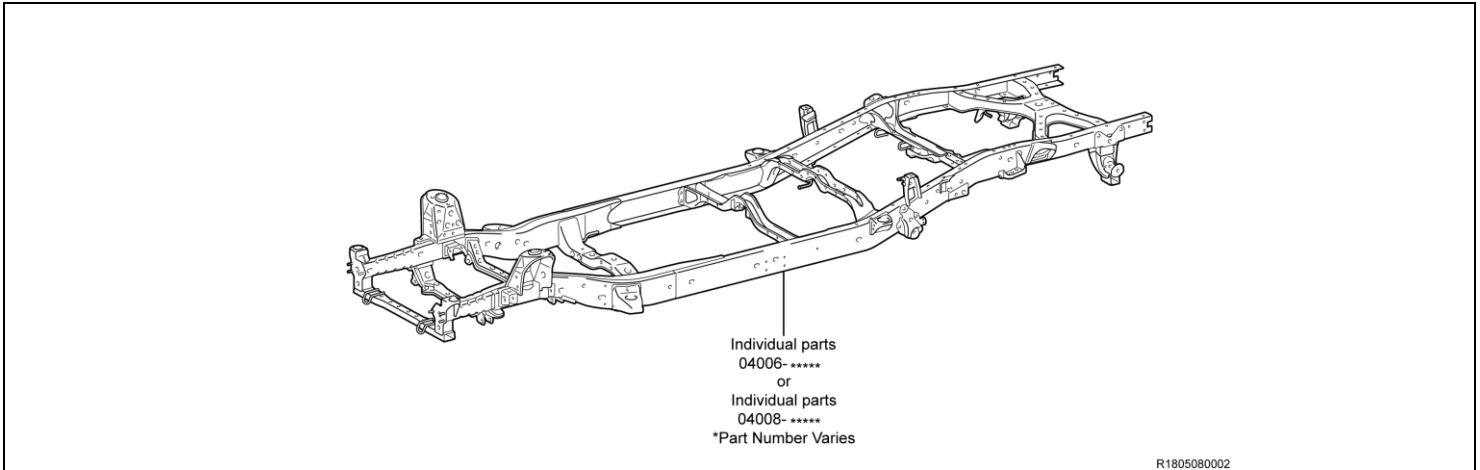

### Cab Mounting

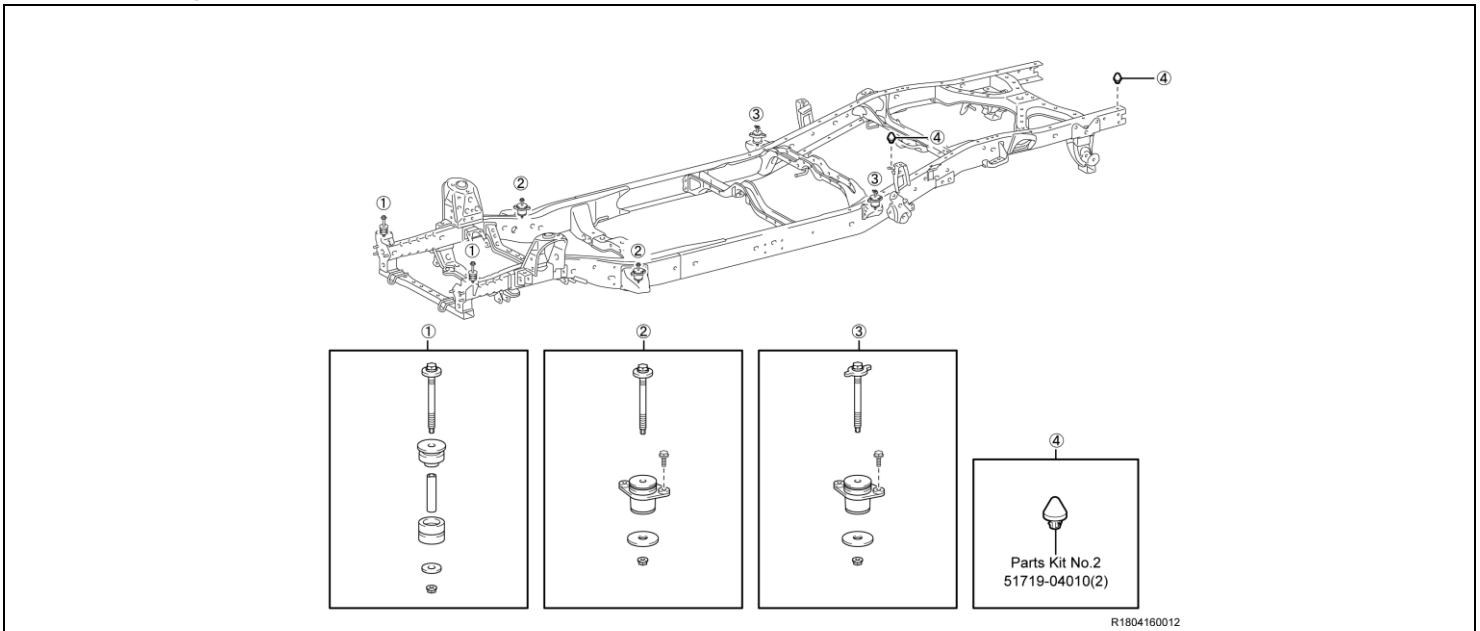

### Under Cover

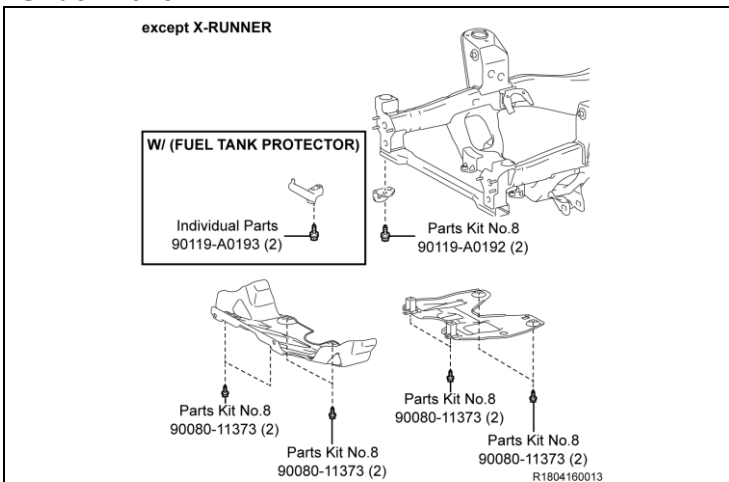

### Spare Tire Carrier

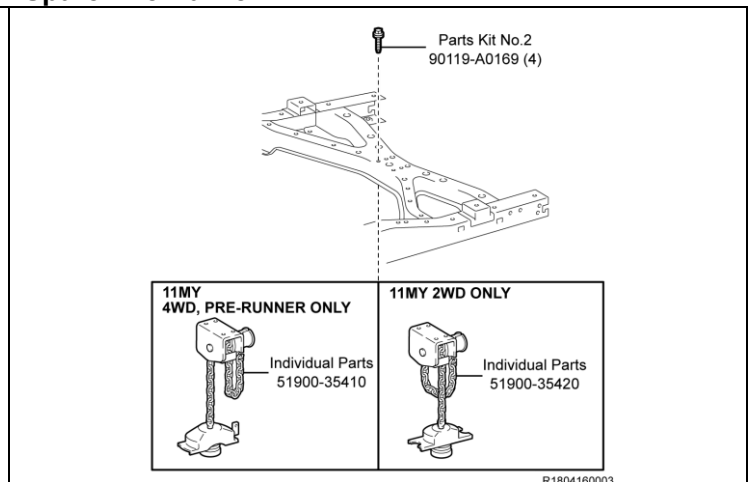

# Front Suspension

2WD ONLY

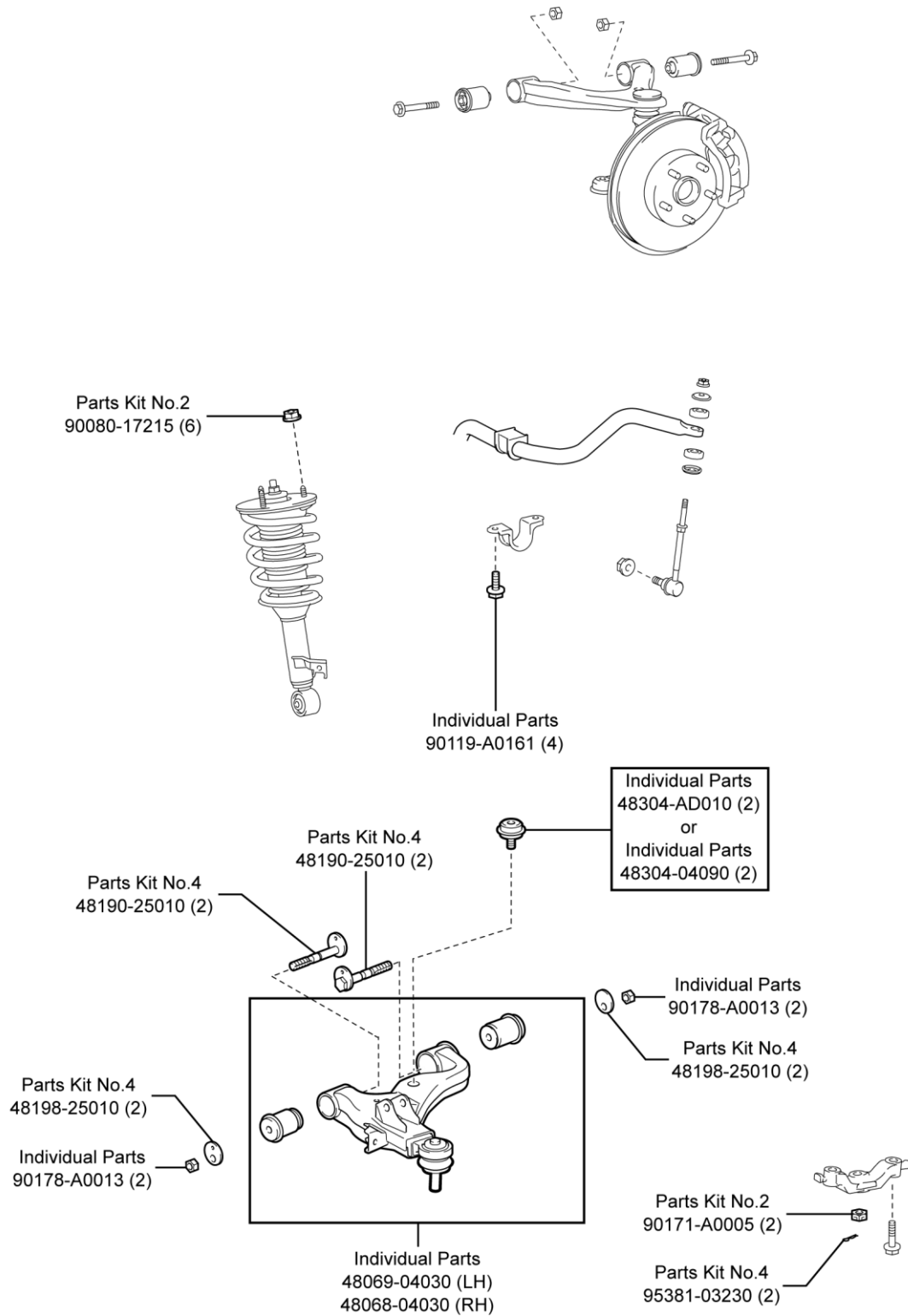

R1804160018

# Front Suspension Continued...

4WD, PRE-RUNNER ONLY

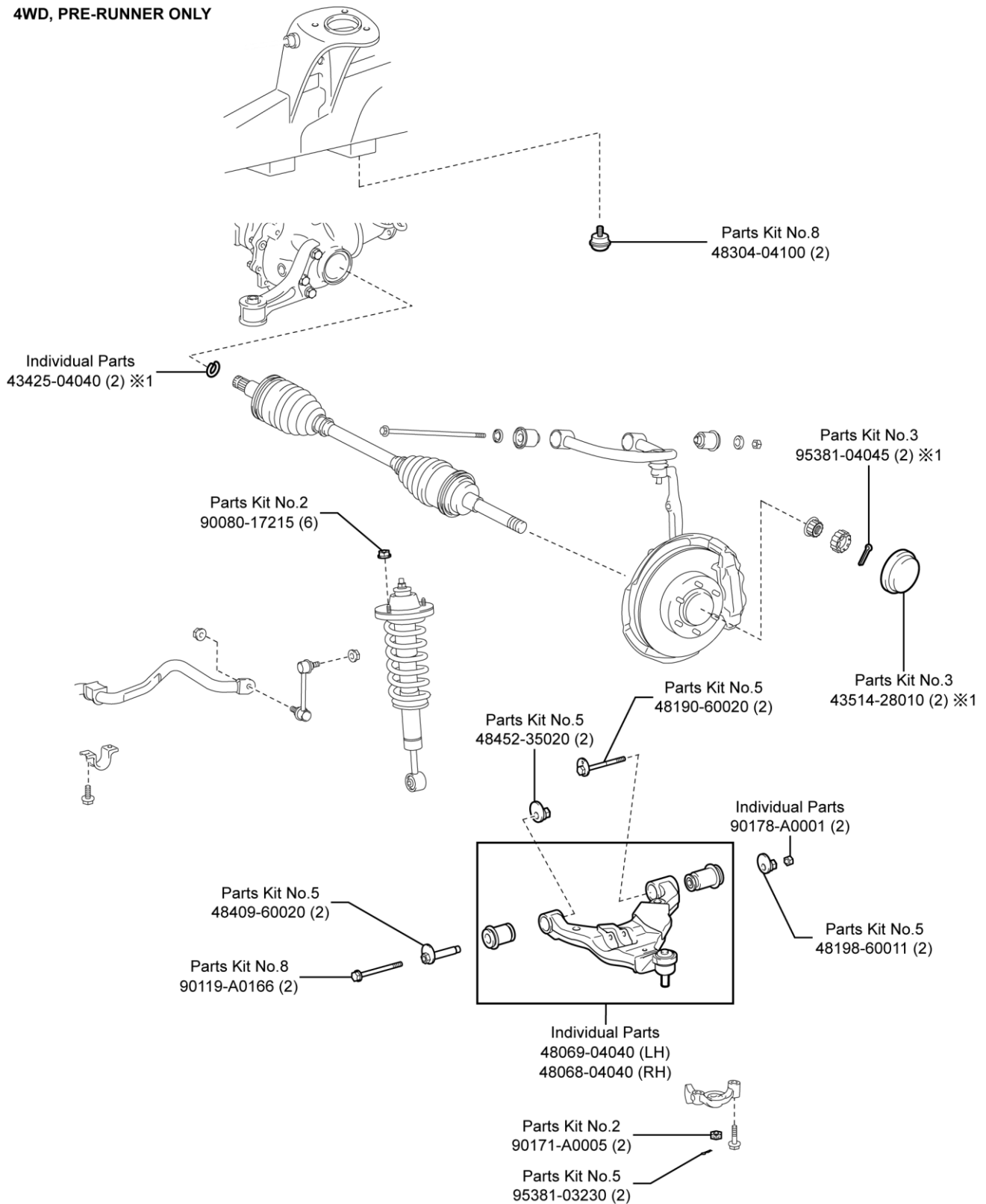

※1 4WD ONLY

R1804160017

# Rear Suspension

X-RUNNER

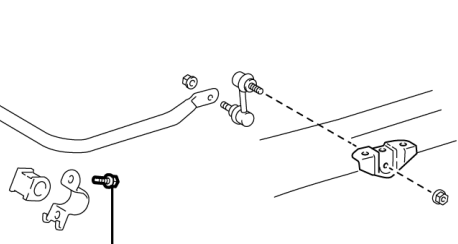

Individual Parts  
90119-08A91 (4)

Parts Kit No.2  
90177-A0010 (2)

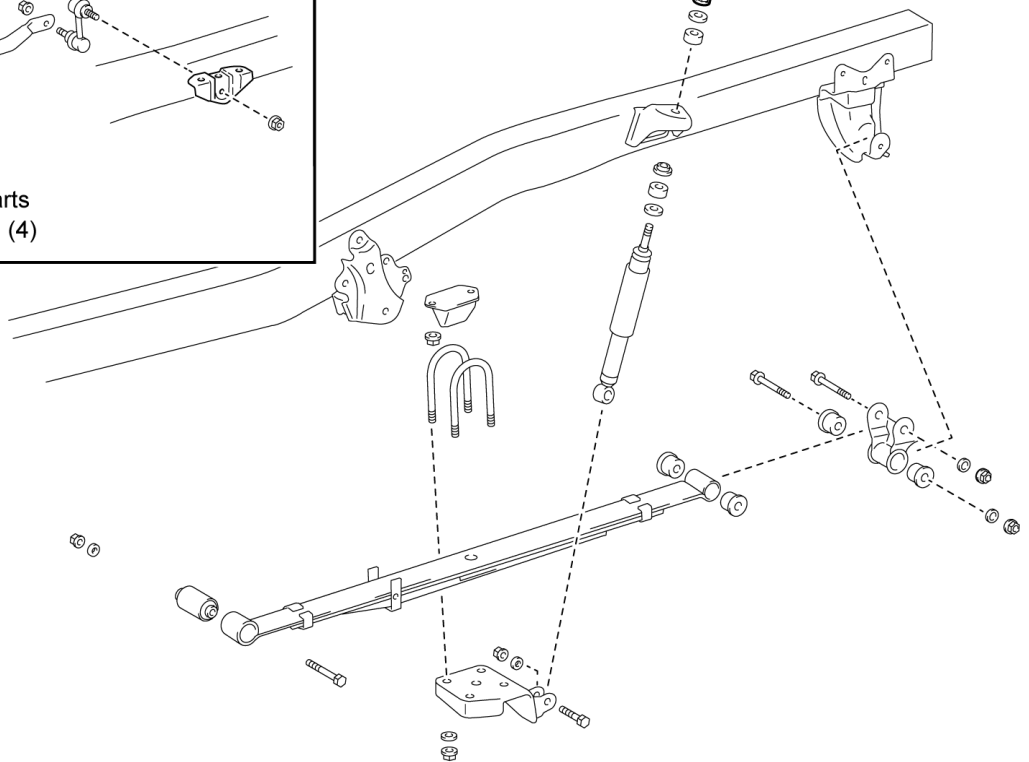

R1804160014

# Brake Tubes

REGULAR CAB  
W/ VSC

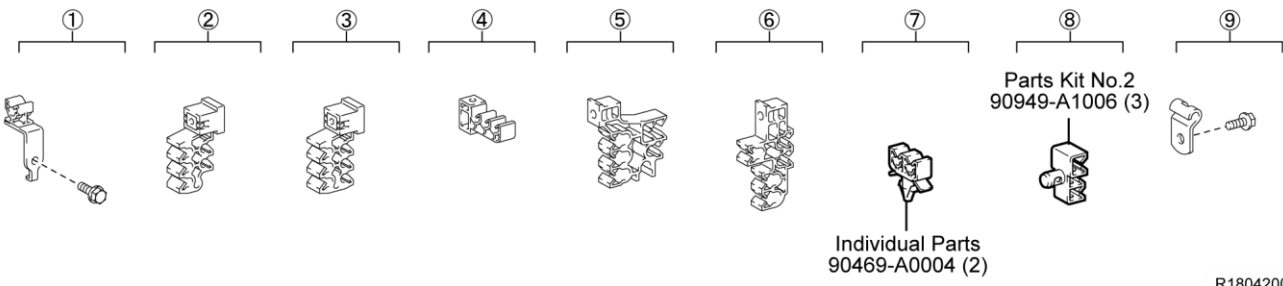
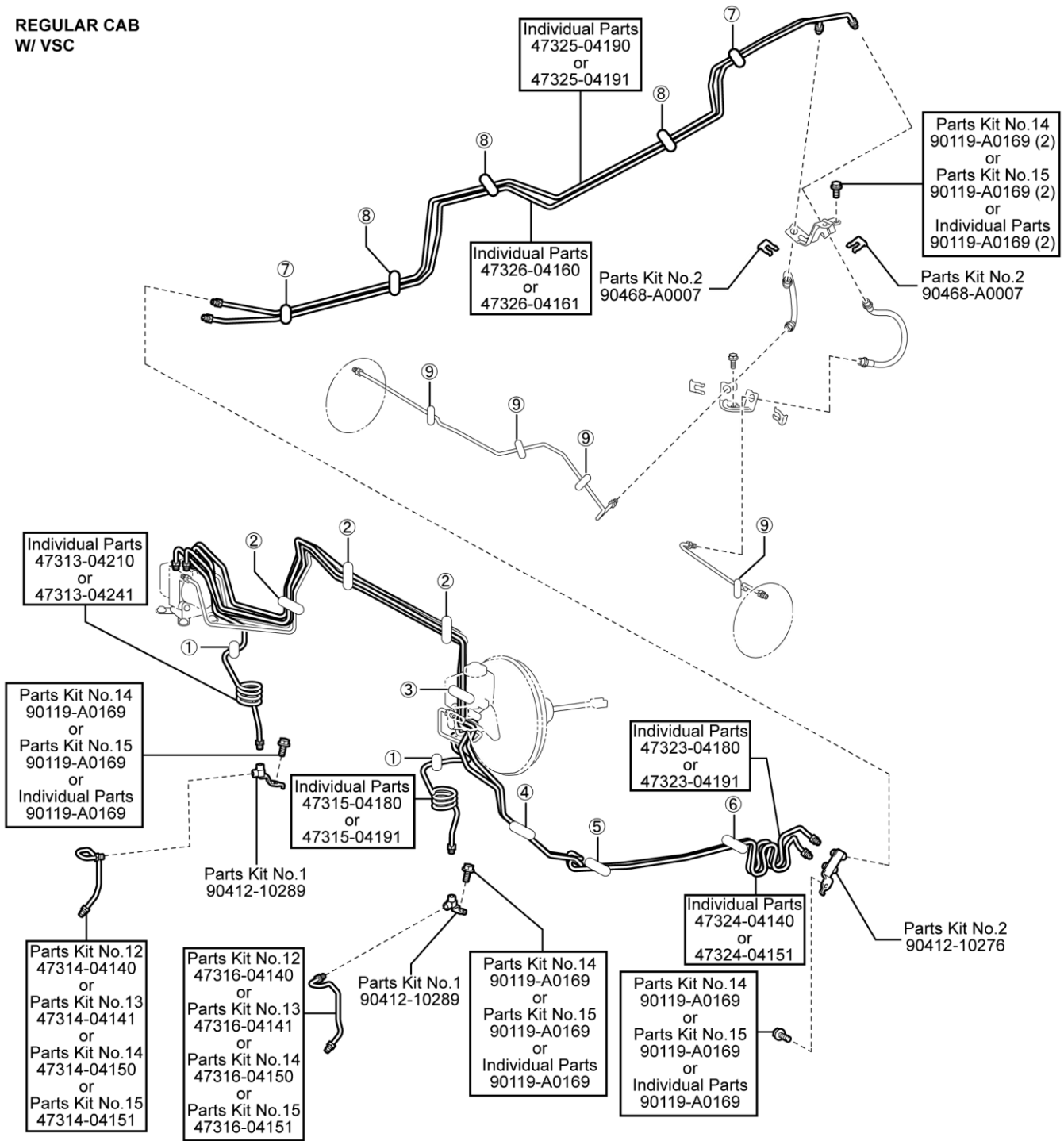

R1804200004



# Brake Tubes Continued...

ACCESS CAB  
W/ VSC

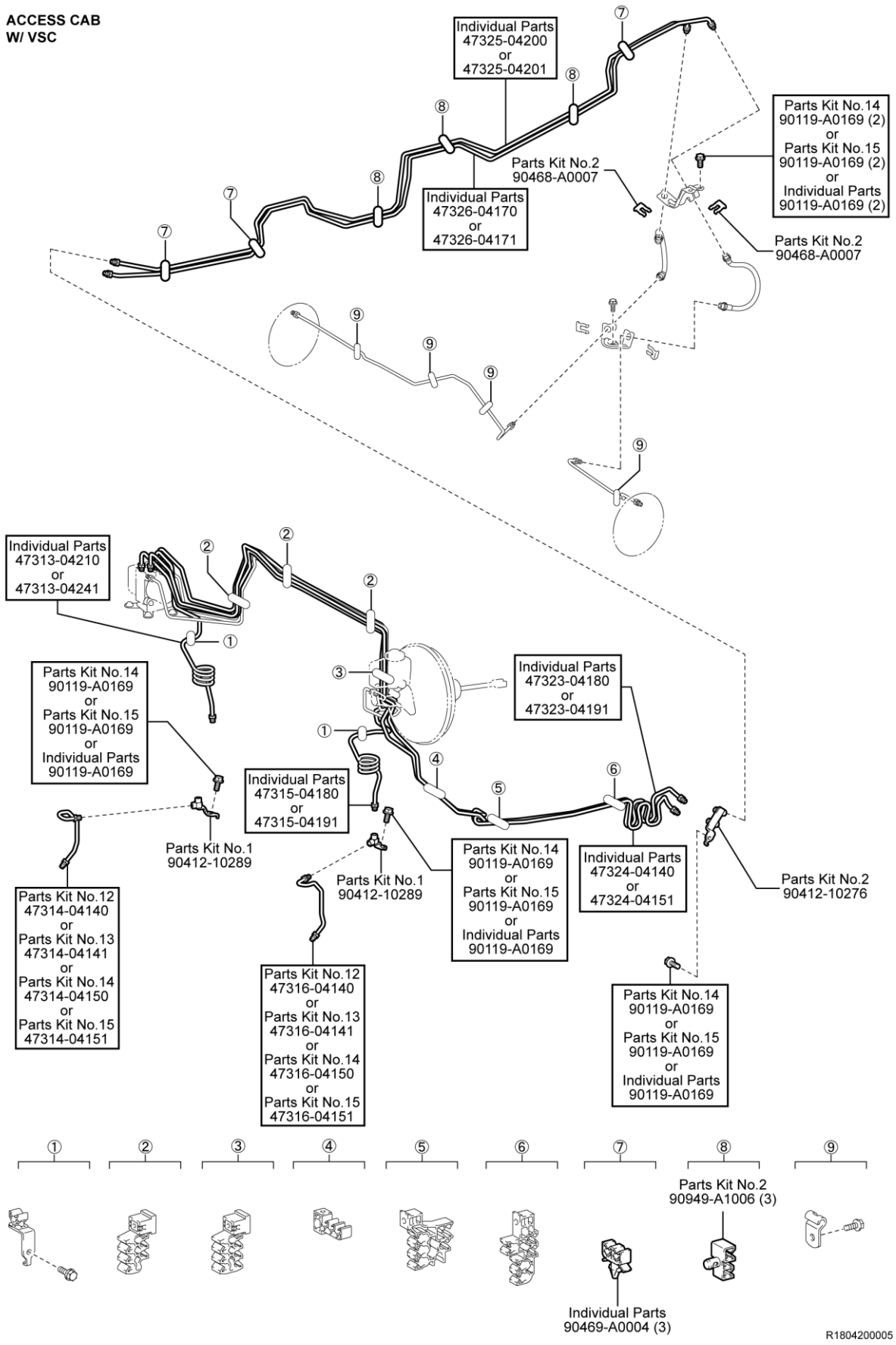

R1804200005

# Brake Tubes Continued...

**ACCESS CAB  
W/ HYDRAULIC BOOSTER**

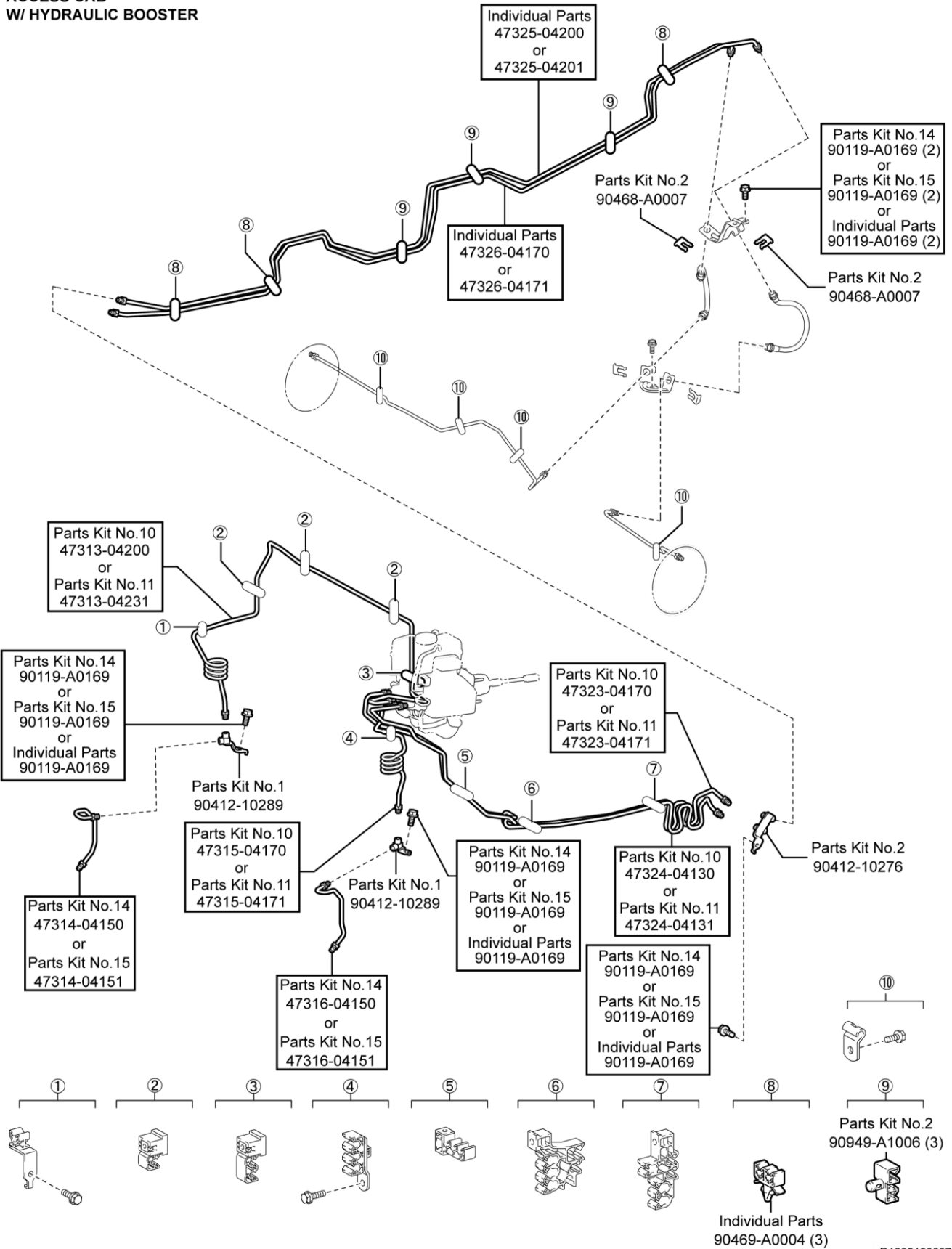

R1805150007

# Brake Tubes Continued...

**DOUBLE CAB  
W/ VSC**

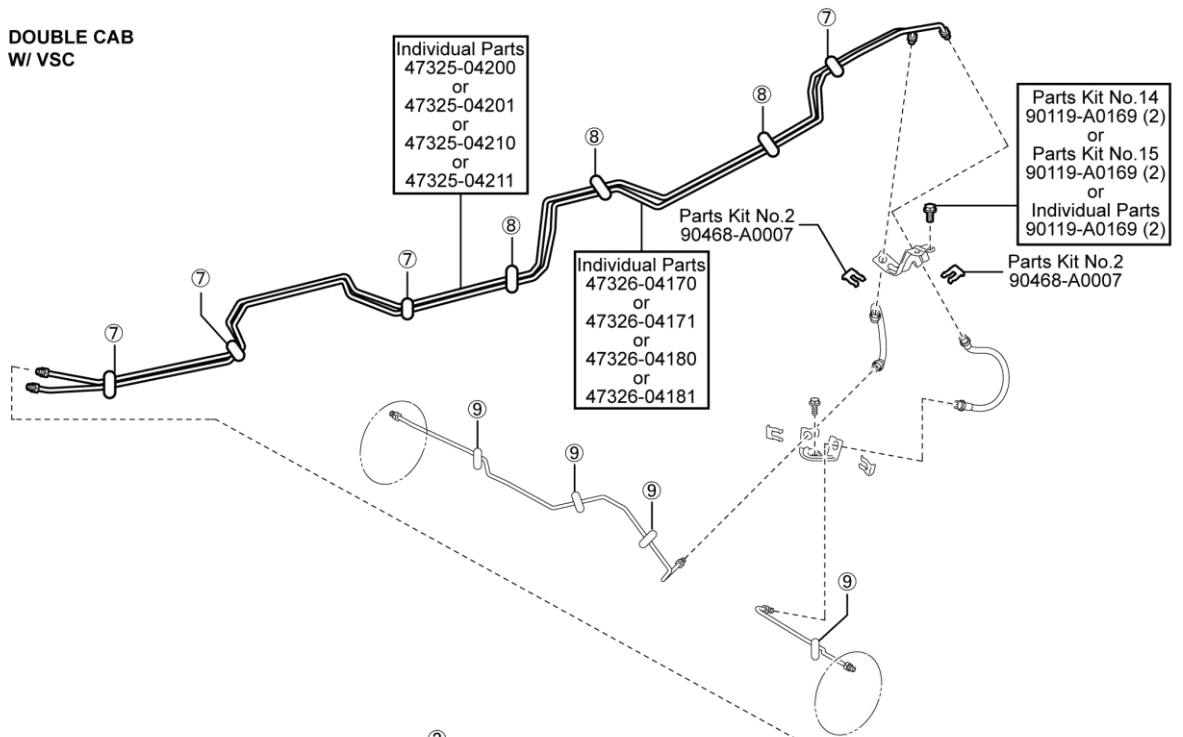

Individual Parts  
47325-04200  
or  
47325-04201  
or  
47325-04210  
or  
47325-04211

Parts Kit No.2  
90468-A0007

Parts Kit No.14  
90119-A0169 (2)  
or  
Parts Kit No.15  
90119-A0169 (2)  
or  
Individual Parts  
90119-A0169 (2)

Individual Parts  
47326-04170  
or  
47326-04171  
or  
47326-04180  
or  
47326-04181

Parts Kit No.2  
90468-A0007

Individual Parts  
47313-04210  
or  
47313-04241

Individual Parts  
47315-04180  
or  
47315-04191

Individual Parts  
47323-04180  
or  
47323-04191

Parts Kit No.14  
90119-A0169  
or  
Parts Kit No.15  
90119-A0169  
or  
Individual Parts  
90119-A0169

Parts Kit No.1  
90412-10289

Parts Kit No.14  
90119-A0169  
or  
Parts Kit No.15  
90119-A0169  
or  
Individual Parts  
90119-A0169

Individual Parts  
47324-04140  
or  
47324-04151

Parts Kit No.2  
90412-10276

Parts Kit No.12  
47314-04140  
or  
Parts Kit No.13  
47314-04141  
or  
Parts Kit No.14  
47314-04150  
or  
Parts Kit No.15  
47314-04151

Parts Kit No.12  
47316-04140  
or  
Parts Kit No.13  
47316-04141  
or  
Parts Kit No.14  
47316-04150  
or  
Parts Kit No.15  
47316-04151

Parts Kit No.14  
90119-A0169  
or  
Parts Kit No.15  
90119-A0169  
or  
Individual Parts  
90119-A0169

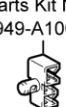
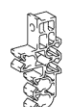
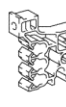
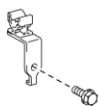

Parts Kit No.2  
90949-A1006 (3)

Individual Parts  
90469-A0004 (4)

R1804200006

# Brake Tubes Continued...

**DOUBLE CAB  
W/ HYDRAULIC BOOSTER**

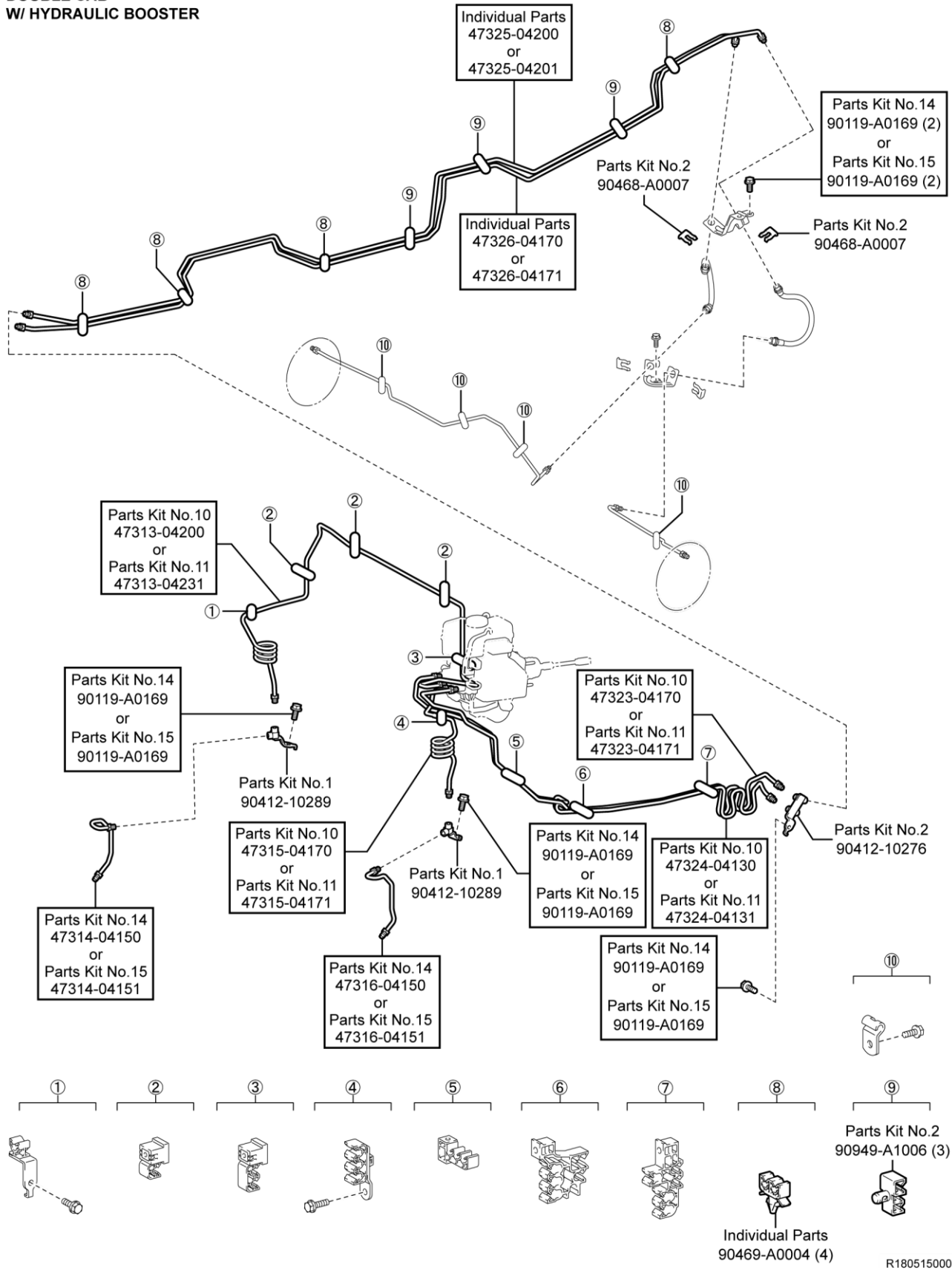

## Brake Tubes Continued...

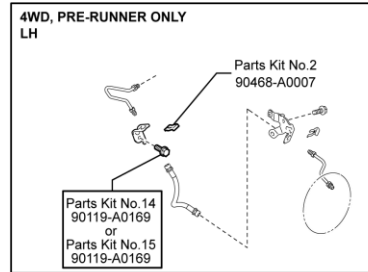
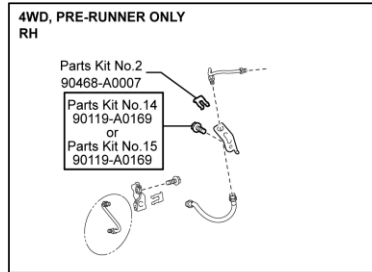
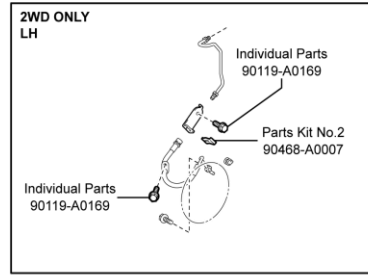
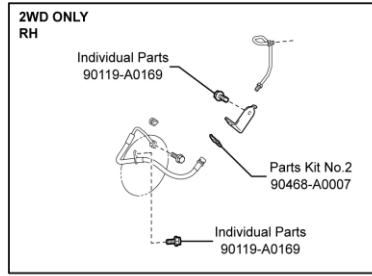

R1804160015

## Fuel Tank

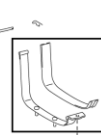
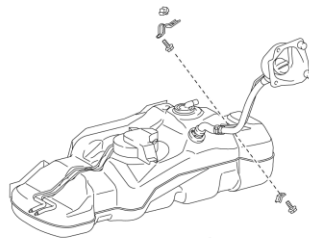

Parts Kit No.2 90119-A0249

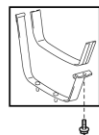

Parts Kit No.2 90119-A0249

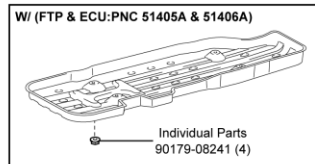

R1804160006

## Fuel Tubes

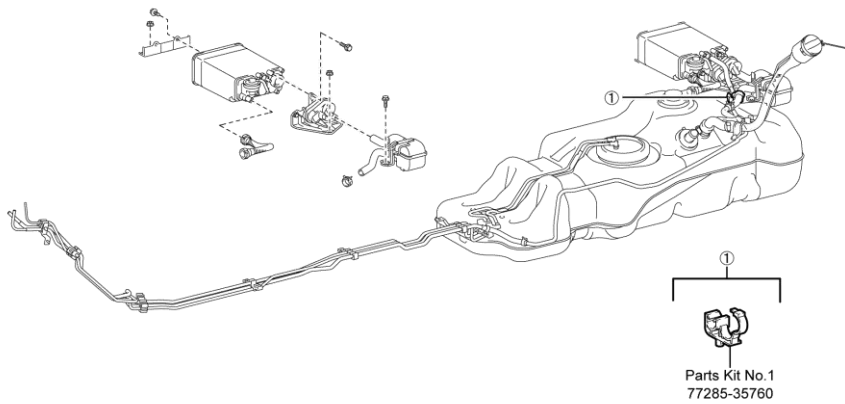

R1804160007

**ABS**

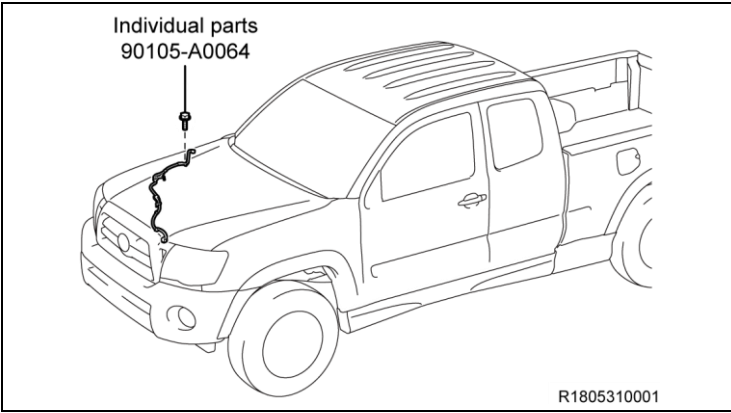

**Wire Harness Brackets**

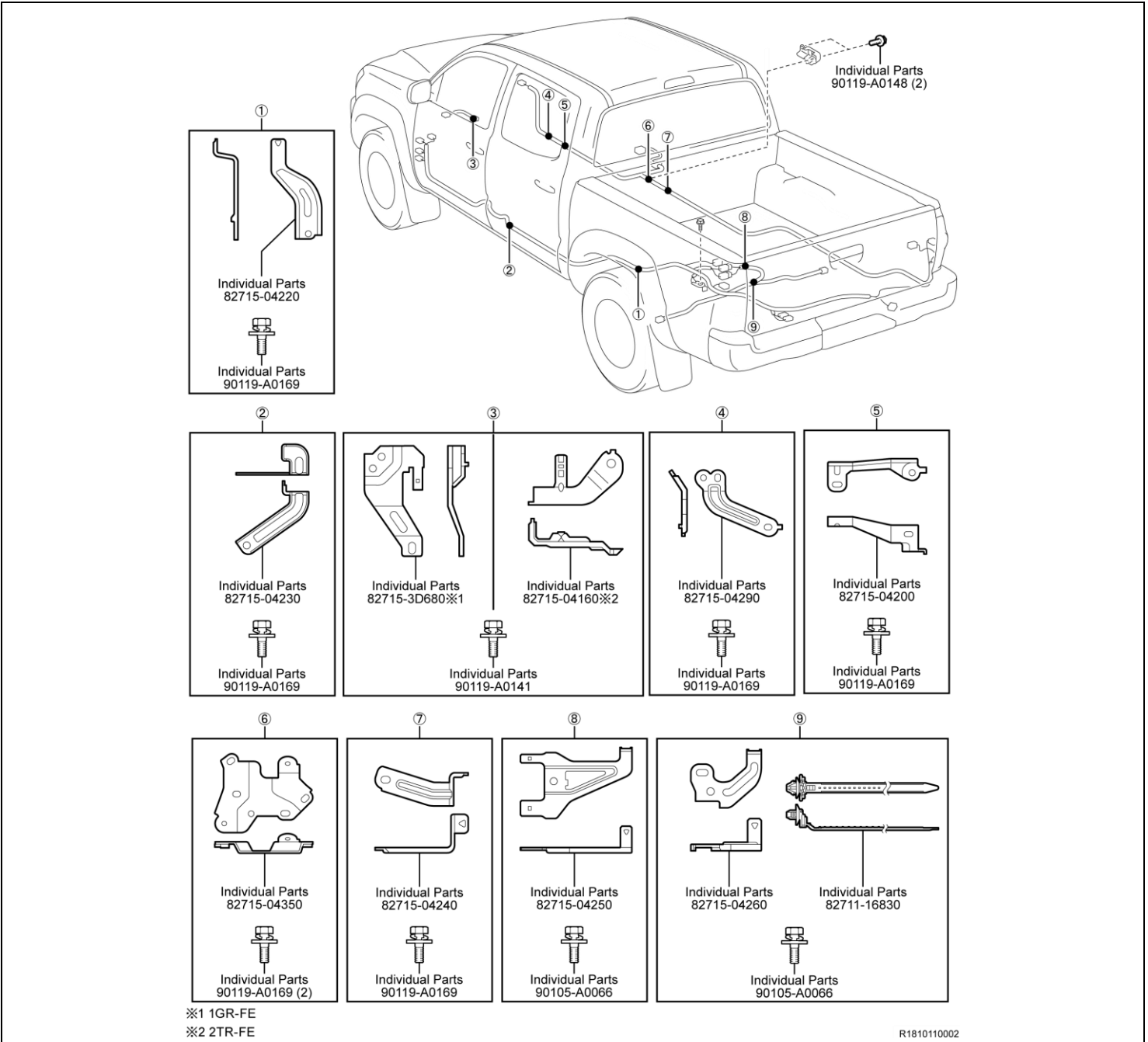

# Power Steering

1GR-FE

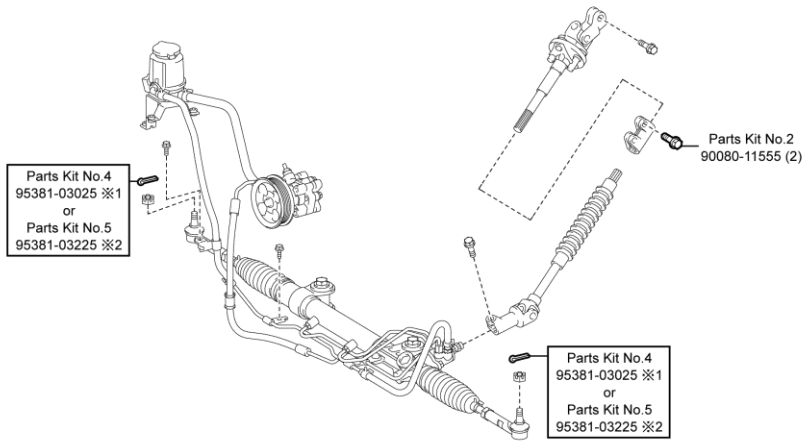

2TR-FE

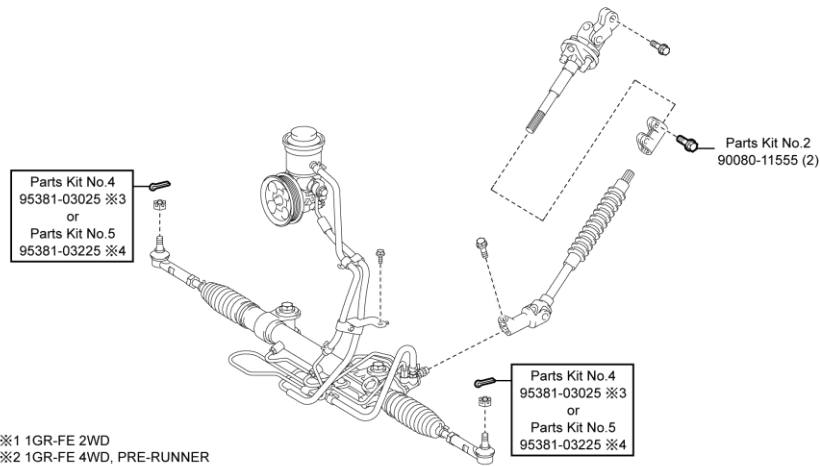

- ※1 1GR-FE 2WD
- ※2 1GR-FE 4WD, PRE-RUNNER
- ※3 2TR-FE 2WD
- ※4 2TR-FE 4WD, PRE-RUNNER

R1804160016

# Front Differential

4WD ONLY

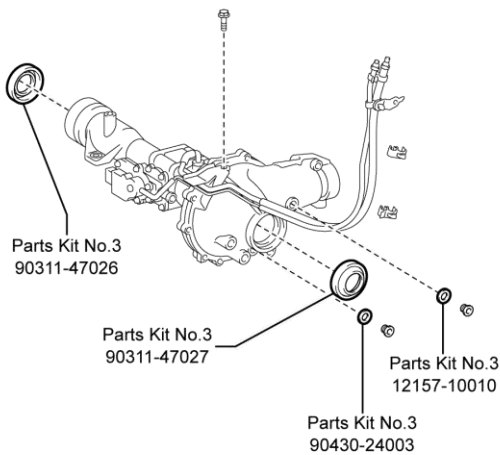

R1804160019

# Engine Mounting

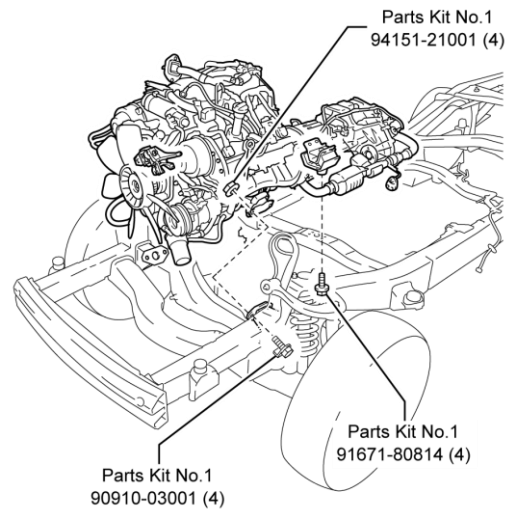

R1805170001

## Propeller Shaft

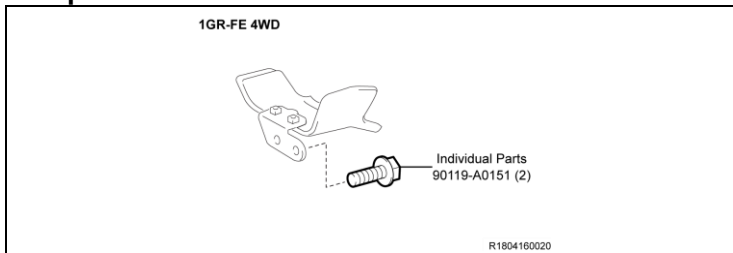

## 1GR-FE Exhaust System

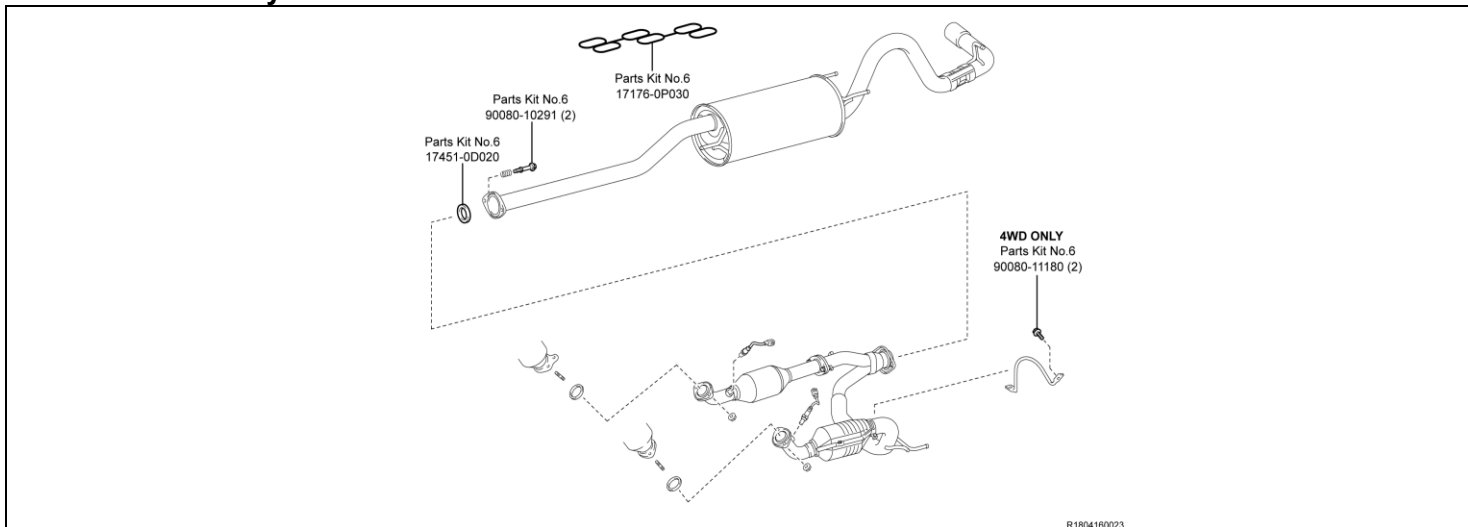

## 2TR-FE Exhaust System

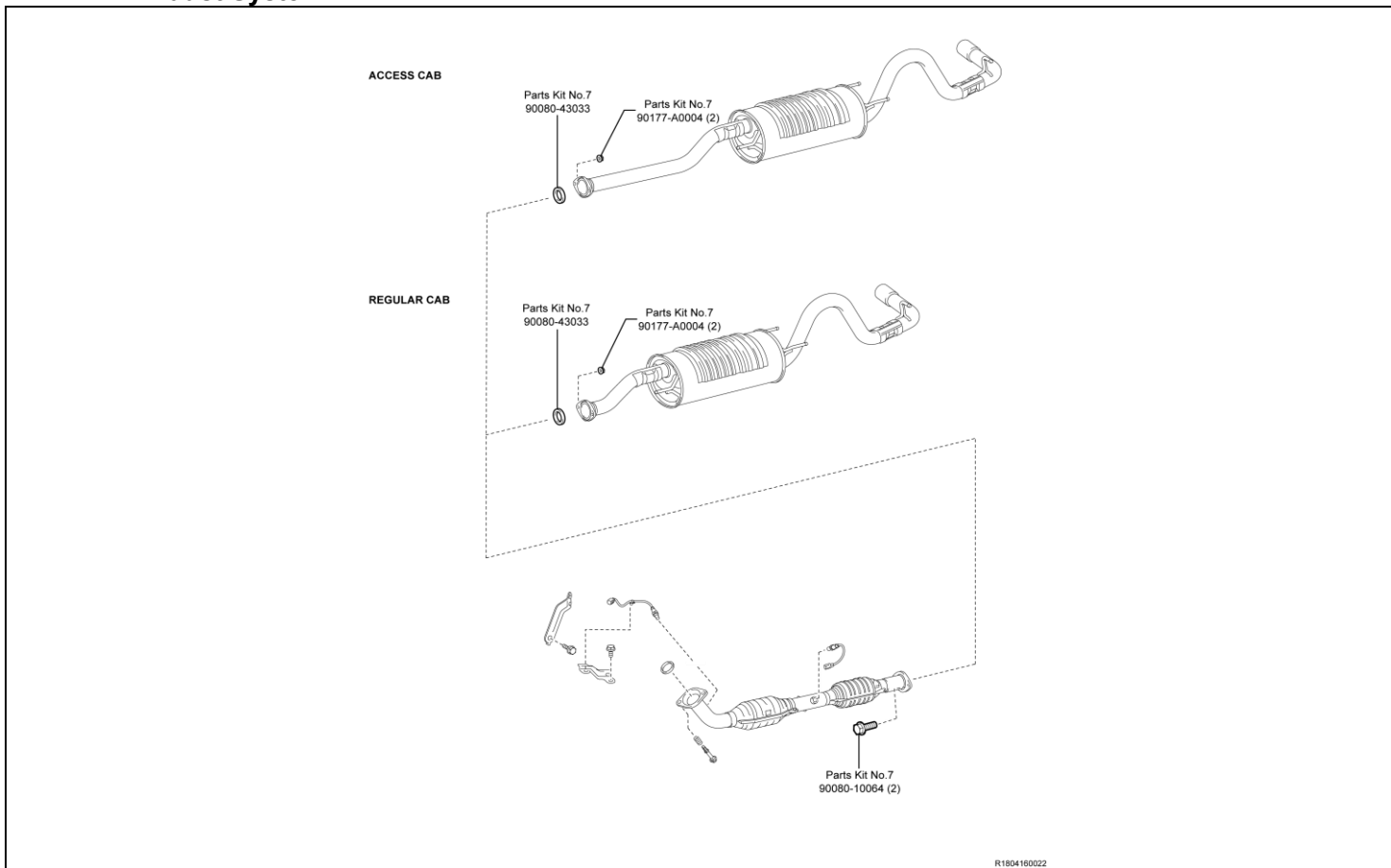



### Shift Lever

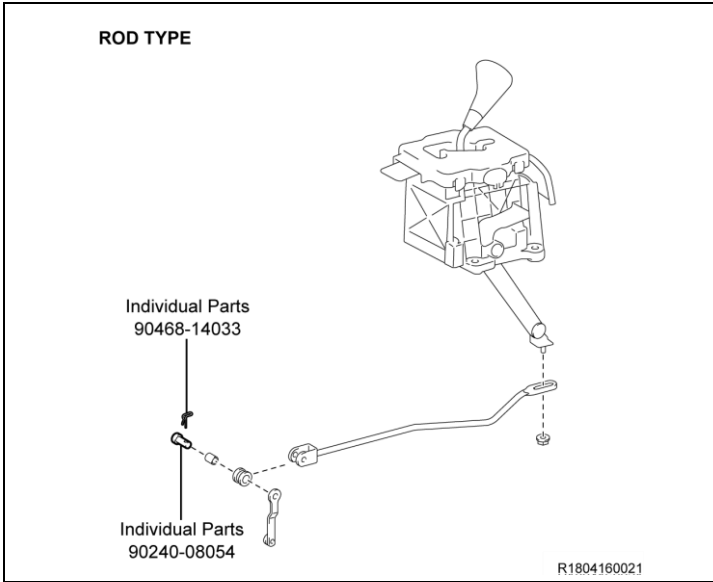

### Radiator

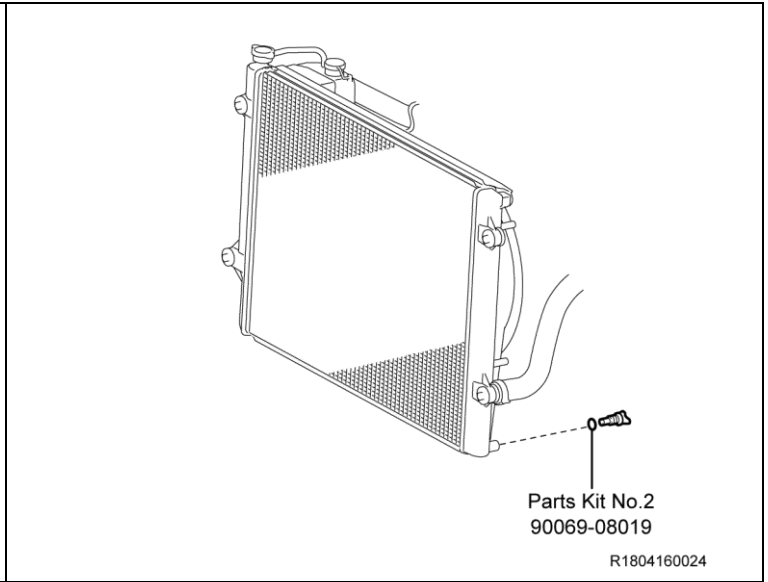

### Air Conditioning

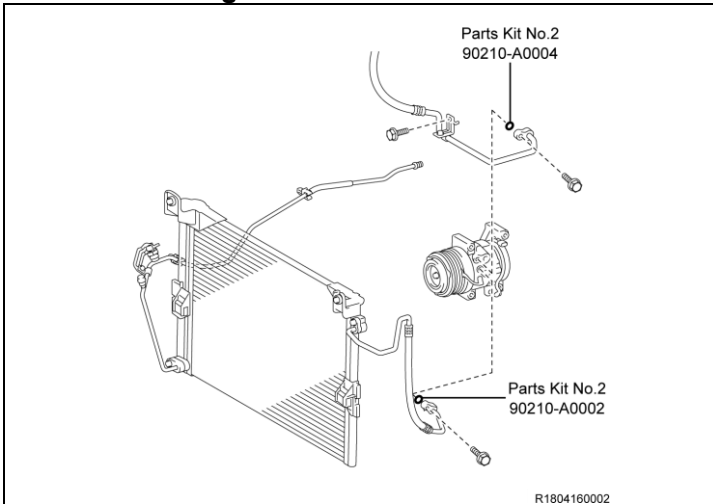

### Front Bumper

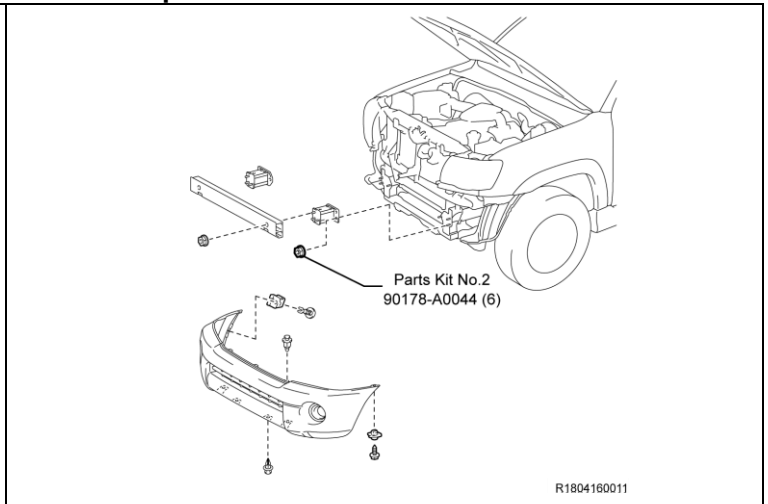

### Rear Bumper

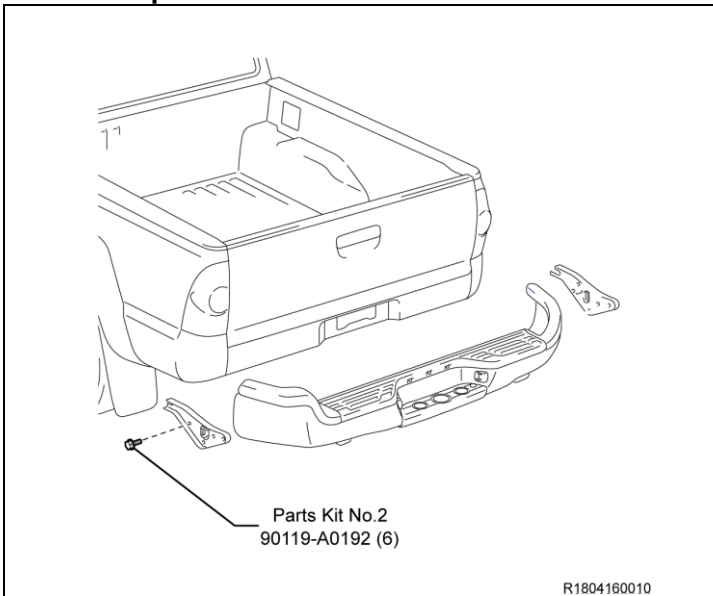

### Rear Wheel House Liner

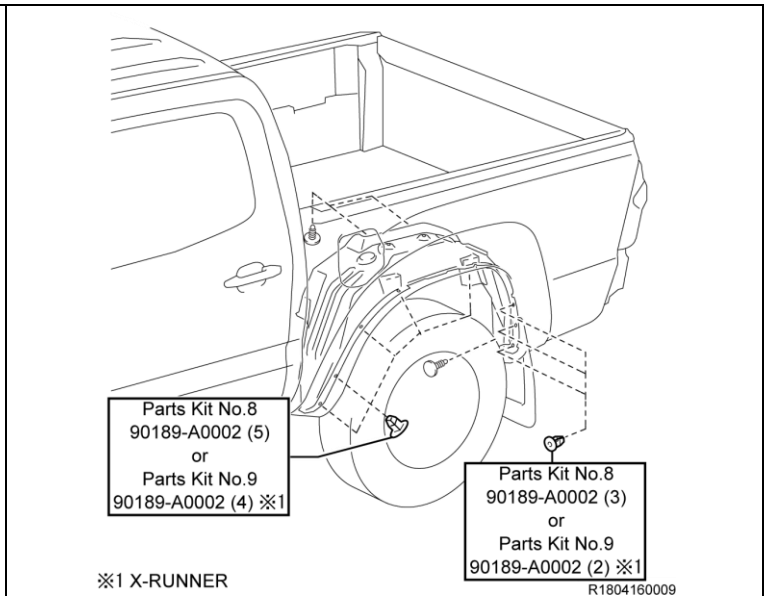

## Moulding

except X-RUNNER

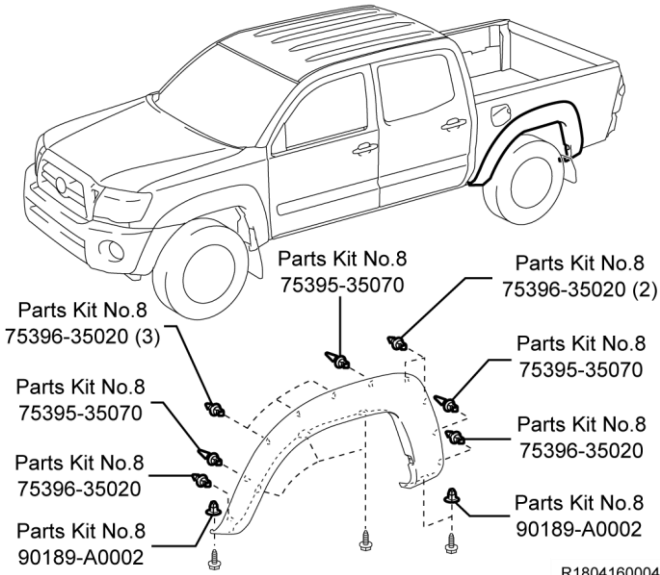

R1804160004

## Moulding Continued...

X-RUNNER

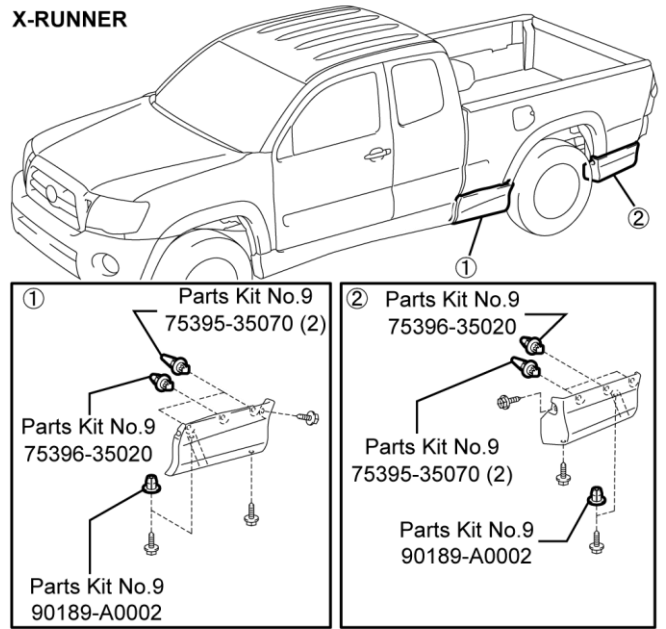

R1804160008

## Moulding Continued...

X-RUNNER

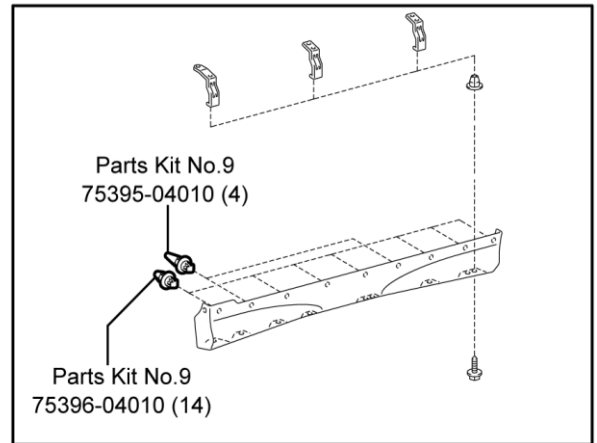
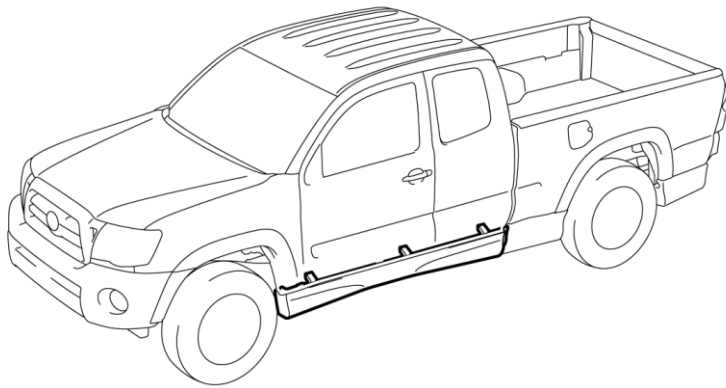

R1804160005

### III. FRAME INSPECTION

#### PERFORM INITIAL PRE-HOIST INSPECTION

1. INSPECT THE FRAME FOR EXCESSIVE FRAME CORROSION THAT COULD AFFECT THE STRUCTURAL INTEGRITY OF THE FRAME

#### FRAME INSPECTION



All frame inspection must be performed using the frame inspection application on TIS. Ensure you inspect the frame and properly document the inspection. Failure to perform this will result in denial of the claim.

#### 1. INSPECT FOR FRAME RAIL SEAL

- a. Inspect if the frame already has a frame rail seal installed as shown in the image below

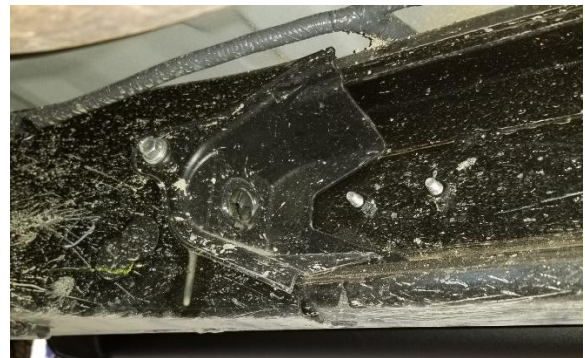
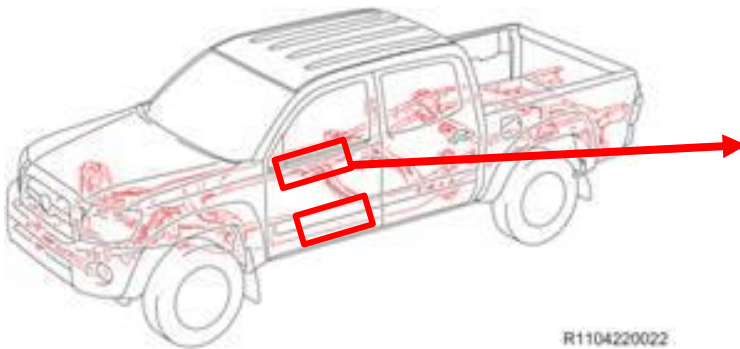

Is the frame rail seal already installed?

YES

NO

No further action required. Campaign is complete

Proceed to the next step in the frame inspection

## 2. ACCESS INSPECTION APPLICATION

- Run the VIN in TIS and click on the Warranty Tab.
- Click on the "Frame Inspection" link on TIS.

**Vehicle Identification Number Search**  
 Enter a 17 Digit VIN below to search for applicable information:  
 VIN:

**Vehicle Information**  
 Division: TOYOTA Model: Tacoma Grade: DLX Model Year: 2010  
 Drive Type: 4WD Body Type: Double Cab Engine Family: V6 - 1GR Engine No: 1GR 8543795  
 Date of First Use: Production Date: 11/20/2009 Plant Code: 4 - FREMONT - NUMMI Transmission:  
 VIN: 8TELU48N0AZ710188 Description: Unknown [MasterParts Catalog](#) [Fluids](#) [Flat Rate Manual](#) [Standard Equipment \(+\)](#)  
 Exterior Color: 03R3, BARCELONA RED METALL Interior Color: P113, P113 Interior Trim Color: P1, \* Interior Fabric: P, \*

Vehicle accessories are not currently available. Try your query again later.

**Vehicle Warranty Information**

**WARRANTY APPLICABILITY QUICK REFERENCE CHART**  
 2010 Tacoma VIN: 8TELU48N0AZ710188 Retailer State: Info Not Found  
 Current Months in service: Last Known Mileage:   State:  CA

Category	Months	Mileage	Eligible
Seal	36	36,000	NO
DEH 12V Auxiliary Battery	36	36,000	NO
Wheel Alignment and Balancing	12	19,000	NO
California Emission Warranty	36	50,000	NO
Short Term	36	70,000	NO
Long Term	96	80,000	YES
Specific Components	96	80,000	YES
Performance Emission Control Warranty	36	30,000	NO
All Parts to pass I/M programs	96	80,000	YES
Specific Components	96	80,000	YES
Powertrain & Restraint Systems	60	60,000	NO
Corrosion Perforation	60	Unlimited	YES
Accessories installed at Vehicle Purchase	36	36,000	NO

**Warranty Policy and Procedures**  
 Warranty coverage is dependent on both the number of months in service and vehicle mileage. If either "Current Months in Service" or "Last Known Mileage" is beyond the applicable warranty coverage, then the vehicle is no longer covered under that warranty category.  
 Please note the information shown above may be subject to change without notice.

**Customer Support Program (CSP)**  
 A CSP enhances portions of the vehicle's warranty coverage for specific conditions. Please see the CSP information for enhancement details.  
 CSP Description: Economic Loss Class Action Settlement - Customer Support Program (CSP)  
 Status: Potentially Eligible  
 Name: This vehicle is included in the model year and range for the Economic Loss Class Action Settlement - Customer Support Program. Please refer to Warranty Policy Bulletin PDL13-02 for additional details.  
 [Show Documents]

CSP Description: Warranty Enhancement Program 2H8 Certain 2005 - 2010 Tacoma Extension of Warranty Coverage for Frame Corrosion  
 Status: Potentially Eligible  
 Name: This Warranty Enhancement Program provides enhanced coverage to the vehicle's "New Vehicle Limited Warranty" as it applies to frame corrosion. The specific condition covered by this program is significant rust perforation (according to Toyota's inspection criteria).  
 [Show Documents]

[Frame Inspection](#)

## 3. LOG INTO THE INSPECTION APPLICATION

- Reenter your TIS password

### Frame Inspection

Language:  English  French  Spanish

Re-enter your TIS Password to proceed with the Frame Inspection

Verify the User ID currently logged into TIS matches the technician's User ID performing the Frame Inspection

TIS Password

**4. ENTER VEHICLE INFORMATION**

- a. Enter the vehicle mileage.
- b. Select the state from the drop down menu that the vehicle is registered.

**Note: Do NOT select the state the dealership is located.**

- c. Select **NO CRC Previously Applied**: Select Frame Button

**Frame Inspection Home**

<b>User ID</b> : JOHNSOJ459	<b>Technician Name</b> : James Johnson
<b>Dealer Code</b> : 54012	<b>Dealer Name</b> : CYPRESS COLLEGE
<b>Date/Time</b> : 07/08/2017 2:12 PM PDT	<b>VIN</b> : 5TBRT38101S125908
<b>Vehicle Mileage</b> : * <input type="text" value="120568"/> Miles	<b>DMY</b> : TOYOTA Tundra 2001
	<b>Vehicle Registered State</b> : * <input type="text" value="VT"/> <input type="button" value="v"/>

Has the vehicle had CRC previously applied to the Frame?  
Click on the appropriate icon below to start the Frame inspection process.

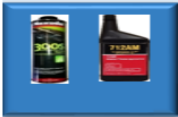

CRC Previously Applied



No CRC Applied

**5. INSPECT THE FRAME SECTIONS**

- a. Inspect the frame in the colored areas below and use the application to document the results of the inspection.

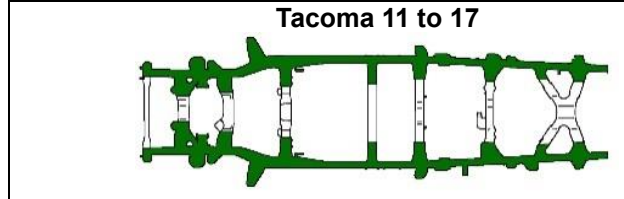

- b. Select Section A

**Note: The frame inspection application must be completed in alphabetical order.**

**Select Frame Section - NO CRC Applied**

<b>User ID</b> : JOHNSOJ459	<b>Technician Name</b> : James Johnson
<b>Dealer Code</b> : 54012	<b>Dealer Name</b> : CYPRESS COLLEGE
<b>Date/Time</b> : 07/08/2017 2:12 PM PDT	<b>VIN</b> : 5TBRT38101S125908
<b>Vehicle Mileage</b> : * 120568 Miles	<b>DMY</b> : TOYOTA Tundra 2001
	<b>Vehicle Registered State</b> : * <input type="text" value="VT"/> <input type="button" value="v"/>

Click on the highlighted section of the frame diagram below to start the inspection process.  
Each section of the frame must be inspected as instructed by the Technical Instructions.  
You must start in Section A (Front Passenger Side of the vehicle) and proceed to each section in alphabetical order.

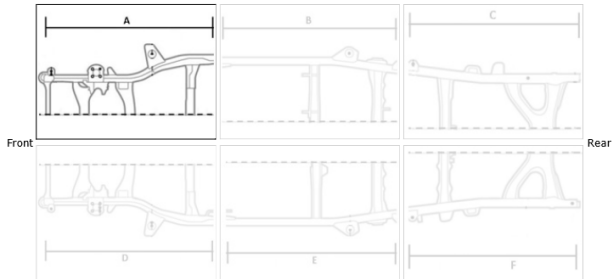

Front  Rear

- c. Inspect the frame section and inspect all surfaces of the frame rail and crossmember. Select the photo that best represents the frame condition. If perforation of 10mm or larger is identified select "Perforation of the Frame".

**Note: You must click the bubble next to the image to select the condition.**

**Frame Inspection**

**Select Frame Condition - NO CRC Applied**

Inspect the frame condition as described in the technical instructions. Ensure to inspect the exterior and interior facing surfaces of the frame rail, along with the crossmembers of the frame. Identify the overall condition of the frame by selecting the appropriate image that best represents the condition of the frame section.

You must click on the bubble next to the image to make your selection.

Note: If there is perforation in any part of the identified frame section always select perforation.

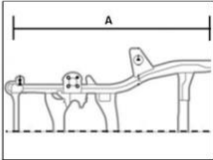

  
E-Coat Intact

  
Light to Moderate Surface Rust

  
Complete Surface Rust with Rust Scales

  
Perforation of the Frame

[Back](#) [Clear](#) [Next](#)

- d. If you selected Perforation of the Frame, the application will request more information about the size of perforation(s) and location.
- e. The section with perforation will split into 2 sub-sections to further identify the perforation location.
- f. Select the size of the perforation in each sub-section.
- g. Upload a photo for each area containing perforation and describe the location in the comments section.

**Note:**

- **Include the R.O in the image of at least one of the perforation holes.**
- **If both sub-sections have perforation, it will require two pictures to be uploaded.**
- **If perforation was accidentally selected, use the back button to reset section.**

- h. Select Next to move onto the next section.

**Frame Inspection**

**Select Perforation Identification - NO CRC Applied**

The frame section has been split into two smaller sections to help clarify to the technical staff where the perforation is located. Please select the location and size of the perforation and upload an image of the perforation.

Note: If perforation is found in both areas please identify both perforation locations below.

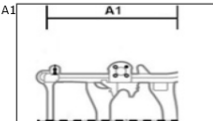

A1 Check the appropriate perforation size\*

Perforation Found during Frame Clearing for CRC-10mm and above

16mm or above

10 to 15mm

None

Comments: (500 Chars)

IMG\_1302.JPG 

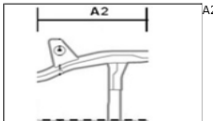

A2 Check the appropriate perforation size\*

Perforation Found during Frame Clearing for CRC-10mm and above

16mm or above

10 to 15mm

None

Comments: (500 Chars)

[Back](#) [Clear](#) [Next](#)



Each image attached has a size limit of 3 MB and all images cannot exceed 15 MB total. If 3MB is uploaded the system will display the error shown below.

User using Chrome browser may receive intermittent errors when uploading several high-quality images, IE is recommended.

**Frame Inspection**

**Select Perforation Identification - NO CRC Applied**

**Please Upload file less than 3MB**  
The frame section has been split into two smaller sections to help clarify to the technical staff where the perforation is located. Please select the location and size of the perforation and upload an image of the perforation.

Note: If perforation is found in both areas please identify both perforation locations below.

**B1** Check the appropriate perforation size\*

Perforation Found during Frame Clearing for CRC-10mm and above

16mm or above

10 to 15mm

None

Comments: (500 Chars)

IMG\_0600.JPG 

**B2** Check the appropriate perforation size\*

Perforation Found during Frame Clearing for CRC-10mm and above

16mm or above

10 to 15mm

None

Comments: (500 Chars)

Upload Images \*  No file chosen

i. Once all sections have been completed, select the Submit button.

**Note: When completed it will be indicated by all sections being grayed out and the submit button will appear.**

**Frame Inspection**

**Frame Inspection - NO CRC Applied**

<b>User ID</b>	: JOHNSOJ459	<b>Technician Name</b>	: James Johnson
<b>Dealer Code</b>	: 54012	<b>Dealer Name</b>	: CYPRESS COLLEGE
<b>Date/Time</b>	: 07/08/2017 2:12 PM PDT	<b>VIN</b>	: 5TBR38101S125908
		<b>DMY</b>	: TOYOTA Tundra 2001
<b>Vehicle Mileage</b>	:* 120568 Miles	<b>Vehicle Registered State</b>	:* VT <input type="button" value="v"/>

Front

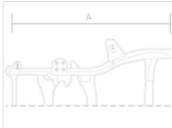

A

Front

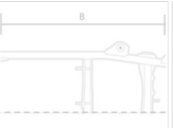

B

Front

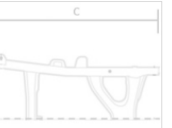

C

Rear

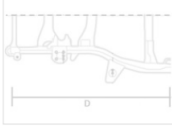

D

Rear

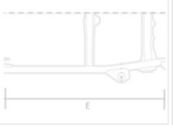

E

Rear

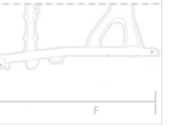

F

## NO Perforation Found

- j. If no perforation was found, follow the directions as provided.

**Frame Inspection**

**Frame Inspection - NO CRC Applied**

<b>User ID</b>	: JOHNSOJ459	<b>Technician Name</b>	: James Johnson
<b>Dealer Code</b>	: 54012	<b>Dealer Name</b>	: CYPRESS COLLEGE
<b>Date/Time</b>	: 07/08/2017 2:12 PM PDT	<b>VIN</b>	: 5TBRT38101S125908
		<b>DMY</b>	: TOYOTA Tundra 2001
<b>Vehicle Mileage</b>	:* 120568 Miles	<b>Vehicle Registered State</b>	:* VT

Frame Inspection Case: FI0000000881  
Inspection Summary: **NO** Perforation

## Perforation Found

- k. If perforation was found, this application will be submitted to your Regional Office for review. The region office will review the inspection and provide feedback if the frame replacement is approved for future repair.



**DO NOT proceed with frame replacement or parts ordering until you are provided with approval from the Regional Office. Approval will be sent to the inspection technician's TIS inbox and Service and Parts Manager email.**

**Frame Inspection**

**Frame Inspection - NO CRC Applied**

<b>User ID</b>	: JOHNSOJ459	<b>Technician Name</b>	: James Johnson
<b>Dealer Code</b>	: 54012	<b>Dealer Name</b>	: CYPRESS COLLEGE
<b>Date/Time</b>	: 07/08/2017 2:12 PM PDT	<b>VIN</b>	: 5TBRT38101S125908
		<b>DMY</b>	: TOYOTA Tundra 2001
<b>Vehicle Mileage</b>	:* 120568 Miles	<b>Vehicle Registered State</b>	:* VT

Frame Inspection Case: FI0000000881  
Inspection Summary: Perforation has been found in Sections A1,C1,C2.  
Toyota Technical Staff will review and provide feedback or authorization for repair.  
Feedback and authorization will be sent to your TIS Inbox when the review has been completed.

[Close](#)



## IV. FRAME REPLACEMENT WORK PROCEDURE

### A. PERFORM PRELIMINARY VEHICLE INSPECTION

1. Perform health check and record any preexisting DTCs
2. Test drive the vehicle and inspect the following vehicle functions/current operating conditions prior to vehicle repair.
  - 4WD System (*4WD Only*)
  - Interior Lights
  - Exterior Lights
  - HVAC System
  - Audio System
  - Power Windows
  - Power Door Locks
  - All Gauges, Indicators and Warning Lights
  - Etc.
3. Documents the current vehicle operating condition on the [Frame Replacement Inspection Sheet](#).

### B. SAFETY CHECKLIST & PRECAUTIONS WHEN DRAINING THE FUEL SYSTEM



- Always remember **“SAFETY FIRST”**.
- Be extremely careful when handling fuel to prevent fires from occurring.
- Before beginning work on the fuel system, perform the following safety check list.
- Before removing any fuel system part, drain all fuel to prevent spilling.

#### 1. AIR VENTILATION

- Perform work in a well-ventilated area.
- DO NOT** work underground or in an area where fuel vapors may fill the room due to poor ventilation.
- Quickly clean up any spilled fuel with a dry cloth and dissipate the fuel vapors.
- Dry all cloths that have come in contact with fuel in a well-ventilated area and dispose of them properly (according to applicable local regulations).

#### 2. FIRES AND IGNITION SOURCES ARE STRICTLY PROHIBITED

- Fires and ignition sources are prohibited while working on the fuel system.
- Clearly display the sign found on the next page stating **“WORKING WITH GASOLINE, NO FIRES OR IGNITION SOURCES”**.
- Smoking is prohibited near the work area.
- DO NOT** work in areas where there are welders, grinders, drills, electric motors, heaters, etc.
- DO NOT** use work lamps or any other electrical appliance due to the risk of sparks flying from the power switch or a rise in temperature.
- DO NOT** use metal hammers while working, due to the risk of flying sparks.
- DO NOT** start any engines or perform any of the above in neighboring work bays.

#### 3. FIRE EXTINGUISHER

- Have a fire extinguisher ready and available before beginning work.

#### 4. PREVENT STATIC ELECTRICITY

- To help prevent static electricity, lightly wet the floor with water, but not to the point where it creates a hazardous working condition.
- Place appropriate warning cones or stand signs around the area as a caution.

#### 5. PRECAUTIONS WHEN USING A LIFT

- For bays equipped with auto lifts, cover all access cover joints with duct tape.
- In the event that fuel has leaked inside the auto lift, remove the access cover and clean up any spilled fuel. Dissipate fuel vapors until the smell is gone.

#### 6. PREVENT THE FUEL FROM SPRAYING

- When disconnecting any fuel tubes, pipes, hoses or connectors there may still be some pressure remaining, even after discharging the system. To prevent the fuel from spraying, cover the tubes, pipes or connectors with a shop rag before disconnecting.
- Remember to always wear protective goggles especially when disconnecting fuel tubes, pipes, hoses or connectors.

#### 7. PREVENT THE FUEL FROM CONTACTING OTHER PARTS

- DO NOT** allow the fuel to come in contact with any parts made of rubber or leather.

#### 8. ASSIGN A SAFETY SUPERVISOR

- Assign a safety supervisor to be in charge of all safety precautions and fire hazards around the work area.

■ Copy And Display When Working

**WORKING WITH  
GASOLINE**

**NO FIRES  
NO IGNITION  
SOURCES**

---

Supervisor

- Copiar y exhibir al trabajar

**TRABAJANDO CON  
GASOLINA  
NINGÚN INCENDIOS  
NINGUNA FUENTE  
DE IGNICIÓN**

Supervisor

### C. DISCHARGE THE FUEL SYSTEM PRESSURE



- **DO NOT** disconnect any part of the fuel system until you have discharged the fuel system pressure.
- Even after discharging the fuel system pressure, place a piece of cloth around the tubes, pipe, hoses and connectors as you separate them to reduce the risk of fuel spraying on yourself, in the engine compartment and onto other parts.
- For additional repair information, please reference the appropriate repair manual in TIS for the vehicle you are working on.

1. CHECK FOR DTCs
2. RECORD THE RADIO STATION PRESETS
3. DISCONNECT THE NEGATIVE (-) BATTERY TERMINAL

**NOTE:** Wait 90 seconds after the negative (-) terminal cable is disconnected from the battery before proceeding. Doing so will prevent the SRS from being deployed (i.e. airbag, seat belt pretensioner, etc.).

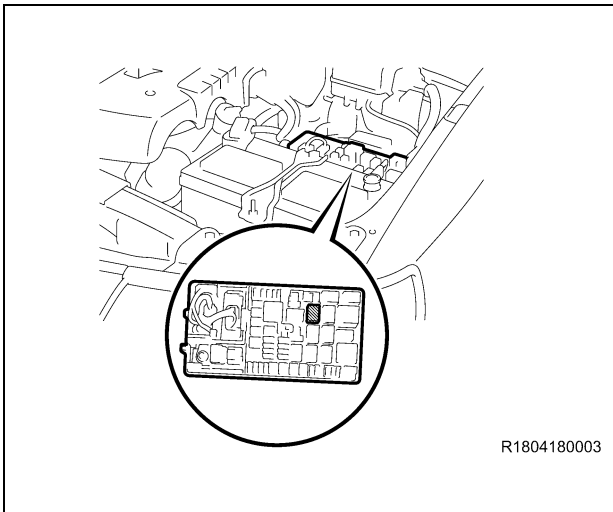

### 4. DISCHARGE THE FUEL SYSTEM PRESSURE

- a) Remove the upper relay block cover.
- b) Remove the circuit opening relay.
- c) Connect the negative (-) battery terminal.
- d) Start the engine.
- e) Turn the ignition switch to ON after the engine stops.  
**NOTE: DTC P0171 (system too lean) may be present.**
- f) Crank the engine again, and check that the engine stops.
- g) Remove the fuel tank cap, and discharge the pressure in the fuel tank completely.
- h) Disconnect the negative (-) battery terminal.
- i) Reinstall the circuit opening relay.
- j) Reinstall the upper relay block cover.

**NOTE:** Reinstall the No.1 upper relay block cover to not let foreign objects enter.

## D. REMOVE THE BED ASSY



- If the frame is perforated, **ONLY** raise the vehicle high enough to remove the tires.
- For added safety and support place jack stands under the front and rear portions of the frame.
- **DO NOT** work directly underneath the vehicle when performing bed assy removal.
- The actual vehicle specs, equipment and parts required may differ than what is shown. Please use the correct specifications and parts for the model you are working on.
- For additional repair information, please reference the appropriate repair manual found on TIS for the vehicle you are working on.

### 1. CENTER THE VEHICLE BETWEEN THE LIFT ARMS

- a) Verify the vehicle is aligned with the center point of the lift to prevent interference and damage to the frame and/or lift.

### 2. REMOVE THE FOLLOWING PARTS

- Rear Tail/Combination Light LH/RH
- Rear Bumper Assy
- Rear Mudguard LH/RH *(If Equipped)*
- Side Step Assy LH/RH *(If Equipped)*
- Rocker Panel Molding LH/RH *(If Equipped)*
- Body Rocker Panel Molding Assy LH *(If Equipped)*
- Outside LH Back Door Molding Sub-Assy *(If Equipped)*
- Quarter Panel Wheel Opening Molding LH *(If Equipped)*
- Left Rear Wheel Well Liner
- Power Outlet Socket Assy *(If Equipped)*



When removing the parts, be careful not to damage them and surrounding components.

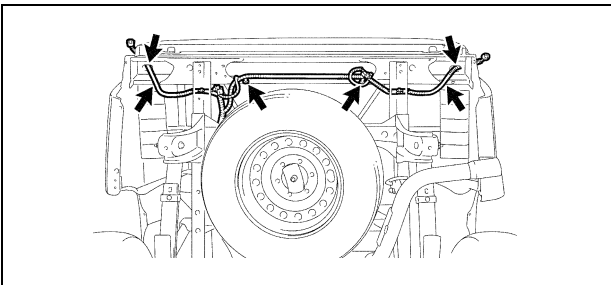

### 3. DISCONNECT THE FRAME WIRE HARNESS

- a) Disconnect the clamps, connectors and the frame wire harness from the bed assy.

#### NOTE:

- The number of connectors may differ depending on the vehicle specification.
- Be careful not to damage the wire harness clamps when removing them.

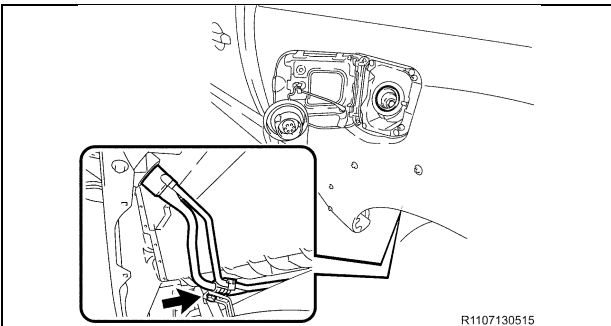

### 4. DISCONNECT THE FUEL INLET PIPE SUB-ASSY

- a) Remove the bolt and disconnect the fuel inlet pipe sub-assy.

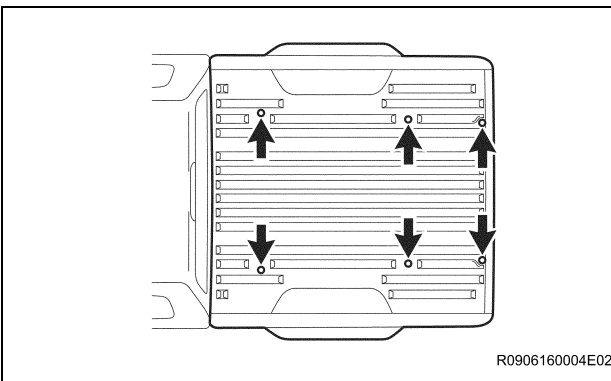

### 5. REMOVE THE BED ASSY

- a) Using a Torx® T55H Socket, remove the 6 Torx ® bolts from the bed assy.

#### NOTE:

- Use 4 or more people to remove the bed assy from the frame.
- Evenly support the bed assy when removing it.
- Be careful not to damage the filler tubes when removing the bed.
- Protect the front side of the bed assy to not damage the cab assy.

## E. REMOVE THE CAB BODY ASSY



- If the frame is perforated, **ONLY** raise the vehicle high enough to remove the tires.
- For added safety and support place jack stands under the front and rear portions of the frame.
- **DO NOT** work directly underneath vehicle when performing cab assy removal, unless noted.
- The actual vehicle specs, equipment and parts required may differ than what is shown. Please use the correct specs and parts for the model you are working on.
- For additional repair information, please reference the appropriate repair manual in TIS for the vehicle you are working on.

### 1. REMOVE THE ENGINE UNDER COVERS

**NOTE:** Use precaution when performing this step, as you will need to work underneath the vehicle.

### 2. EVACUATE THE REFRIGERANT FROM THE AIR CONDITIONING SYSTEM

### 3. DRAIN THE FOLLOWING FLUIDS

- Coolant
- Brake Fluid
- Clutch Fluid (*1GR-FE Manual Trans Only*)
- Front Differential Fluid (*4WD Only*)

**NOTE:** **DO NOT** remove the radiator cap while the radiator and engine are hot, doing so may cause the coolant to spray out causing potential injuries.

### 4. REMOVE THE FOLLOWING BODY COMPONENTS

- Radiator Grille
- Front Bumper Filler LH/RH (*Except 2011MY*)
- Front Fender Mudguard LH/RH
- Front Bumper Assy
- Front Bumper Reinforcement
- Front No.2 Bumper Extension Sub-assy LH/RH

### 5. REMOVE THE FOLLOWING INTERIOR COMPONENTS

- Front Door Scuff Plate LH/RH
- Front Floor Footrest
- Cowl Side Trim Board LH/RH

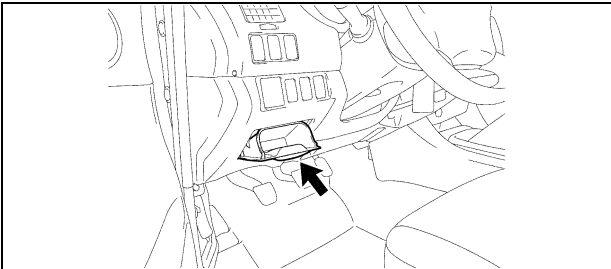

### 6. REMOVE THE INSTRUMENT PANEL BOX

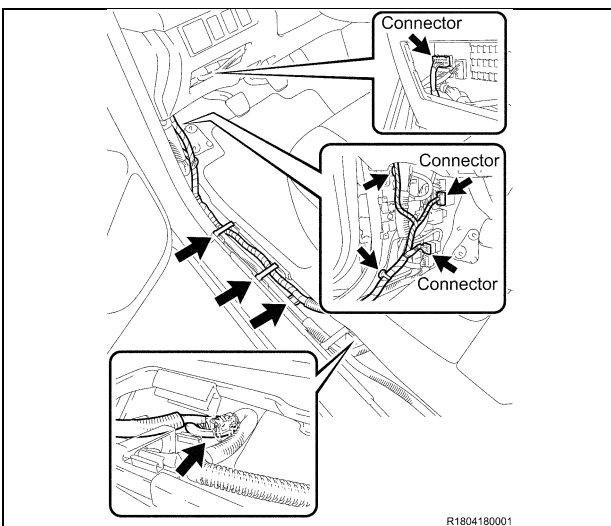

### 7. DISCONNECT THE FRAME WIRE HARNESS

- a) Disconnect the 5 clamps.
- b) Disconnect the connector(s).

**NOTE:** The number of connectors may differ depending on the model.

- c) Remove the frame wire harness grommet from the cab assy.
- d) Pull out the frame wire harness from the vehicle cab assy.

R1804180001

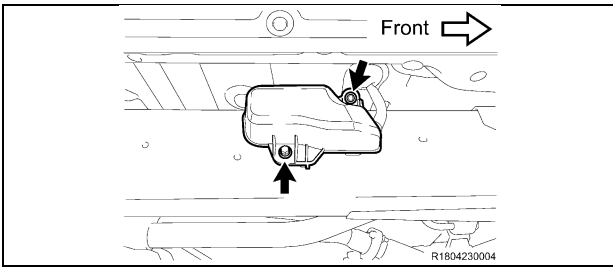

**8. DISCONNECT THE NO.2 FRAME WIRE HARNESS (IF EQUIPPED)**

**For Frame Connecting Type:**

- a) Remove the 2 bolts and cover.
- b) Disconnect the 2 connectors and clamp.

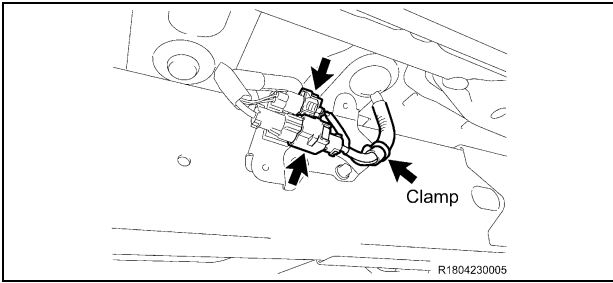

**For Floor Connecting Type:**

- c) Remove all 4 passenger side seat rail bolts.
- d) Tilt the passenger side seat backwards.
- e) Turn back the floor carpet.
- f) Remove the bolt and wiring harness protector.

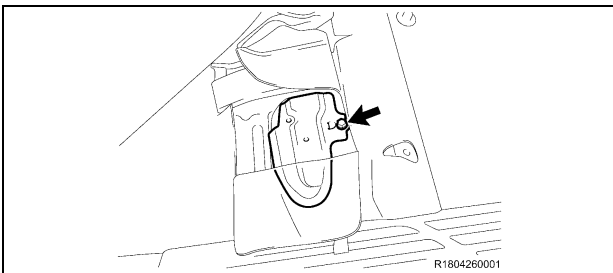

- g) Disconnect the 2 connectors.
- h) Remove the No.2 frame wire harness grommet from the cab assy.
- i) Pull out the No.2 frame wire harness from the cab assy.

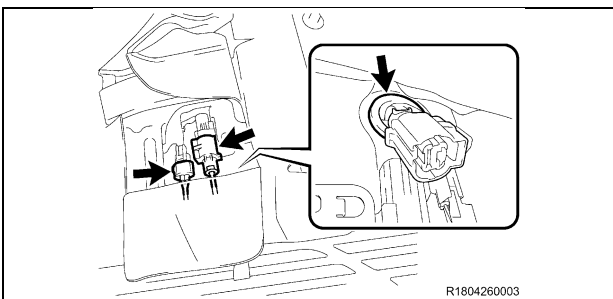

**9. REMOVE THE GLOVE BOX AND LOWER INSTRUMENT PANEL FINISH PANEL**

- a) Remove the glove box.
- b) Remove the bolt and the lower instrument panel finish panel.
- c) Disconnect the radio setting condenser connector. *(If Equipped)*

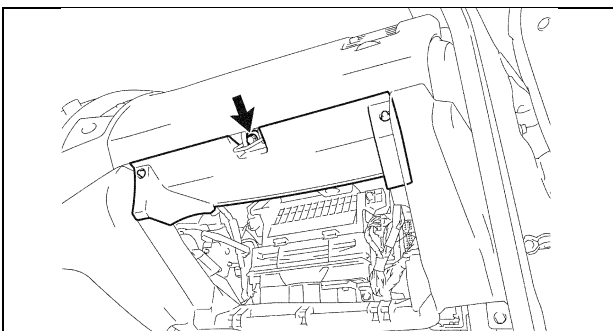

**10. DISCONNECT THE ENGINE WIRE HARNESS**

- a) Disconnect each connector and clamp from the ECM and remove the engine wire harness.

**NOTE: The number of connectors may differ depending on the model.**

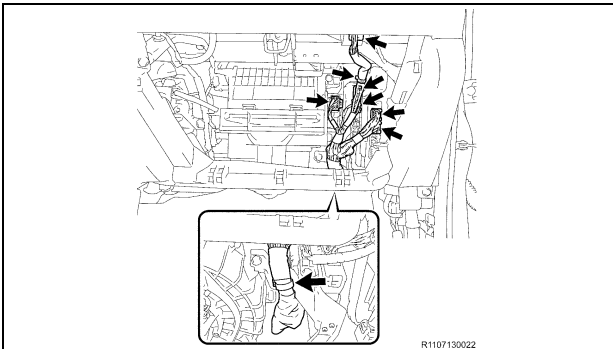

## 11. REMOVE THE FOLLOWING PARTS

- Rear Console Box (*for Separate Seat Type*)
- Front Console Box (*Manual Trans Only*)

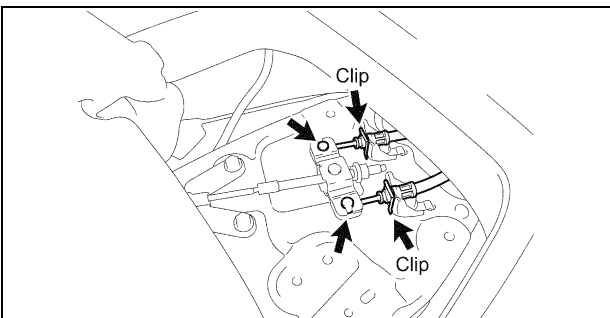
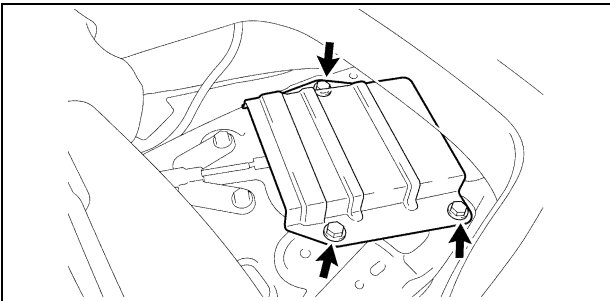
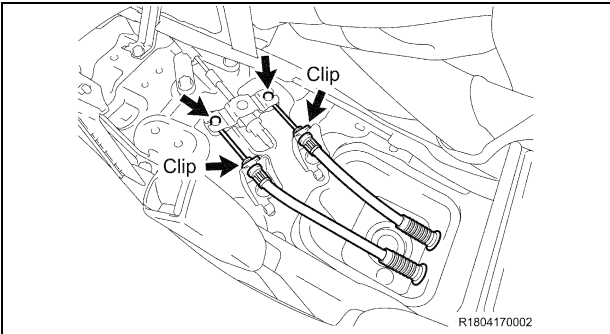

## 13. REMOVE THE FOLLOWING PARTS

- V-Bank Cover (*1GR-FE Only*)
- Air Cleaner Hose and Air Cleaner Assy (*2TR-FE Only*)

- Air Cleaner Assy (*1GR-FE Only*)

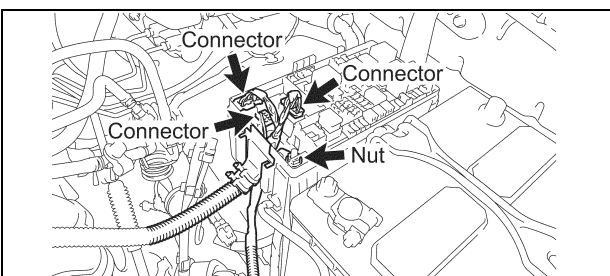
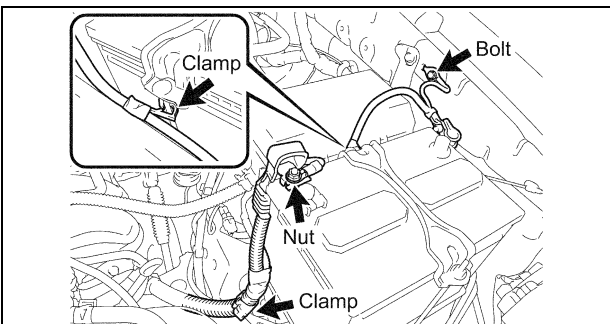

## 12. DISCONNECT THE PARKING BRAKE CABLES

### For Separate Seat Type:

- Remove the 2 clips.
- Disconnect the 2 parking brake cables.

### For Bench Seat Type:

- Turn back the floor carpet.
- Remove the 3 bolts and the parking brake cable joint protector.

- Remove the 2 clips.
- Disconnect the 2 parking brake cables.

## 14. DISCONNECT THE NO.2 ENGINE WIRE HARNESS

- Remove the nut and disconnect the (+) positive battery cable.
- Remove the bolt and disconnect the ground wire.
- Disconnect the 2 clamps.
- Remove the upper relay block cover.
- Disconnect the 3 connectors.
- Remove the nut and disconnect the fuse box wire harness.
- Reinstall the upper relay block cover.



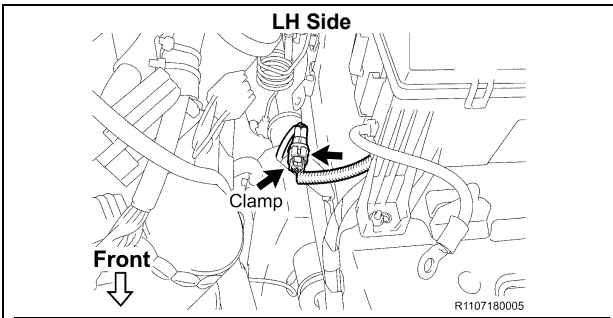

**15. DISCONNECT THE FRONT SKID CONTROL SENSOR WIRE HARNESS**

- a) Disconnect the harness clamp and front skid control sensor connector.
- b) Repeat the procedure on the opposite side.

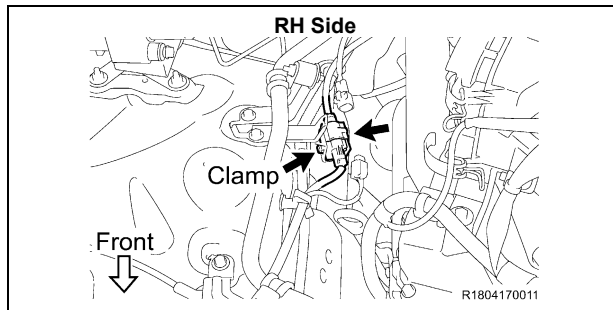
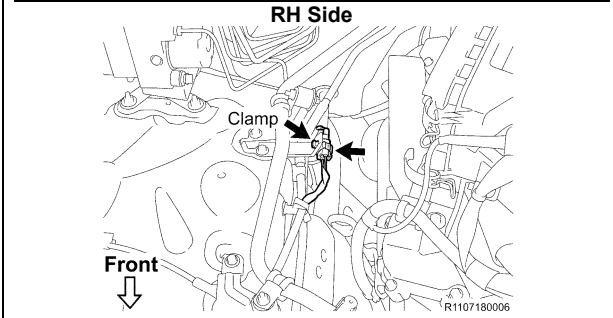

**16. DISCONNECT THE NO.2 FRAME WIRE HARNESS (IF EQUIPPED)**

- a) Disconnect the harness clamp and connector.

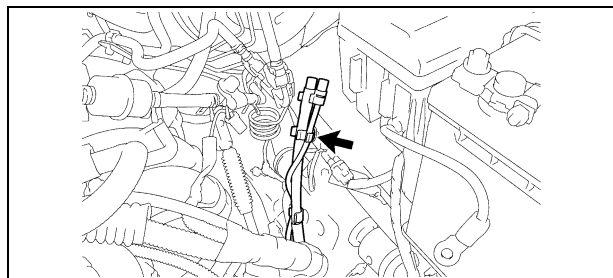

**17. DISCONNECT THE FRONT DIFFERENTIAL BREATHER TUBES (4WD ONLY)**

- a) Disconnect the front differential breather tubes.

**NOTE:** There may be 2 front differential breather tubes depending on the vehicle model.

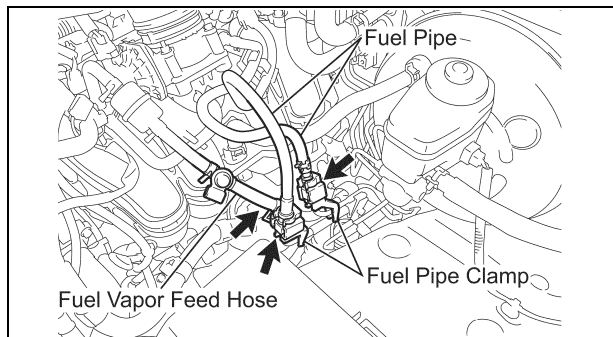

**18. DISCONNECT THE FUEL PIPES AND VAPOR FEED HOSE**

- a) Remove the 2 fuel pipe clamps.
- b) Disconnect the No. 1 and No. 2 fuel pipe.
- c) Remove the clip and disconnect the fuel vapor feed hose.

**NOTE:** Put a shop towel under the fuel pipe to catch any spilled fuel.

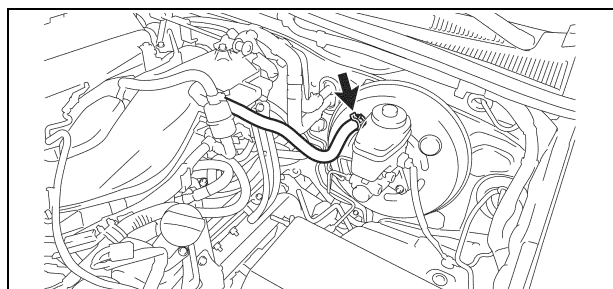

**19. DISCONNECT THE VACUUM HOSE**

- a) Disconnect the vacuum hose.

## 20. DISCONNECT THE RADIATOR HOSES AND AUTO TRANS COOLING LINES (Auto Trans Only)

- Disconnect the inlet and outlet radiator hoses from engine.
- Disconnect the inlet and outlet auto transmission cooling lines from the radiator



Be careful not to damage the radiator hoses.

## 21. REMOVE THE FOLLOWING PARTS

- Radiator Support to Frame Seal
- Fan Shroud
- Radiator Assy

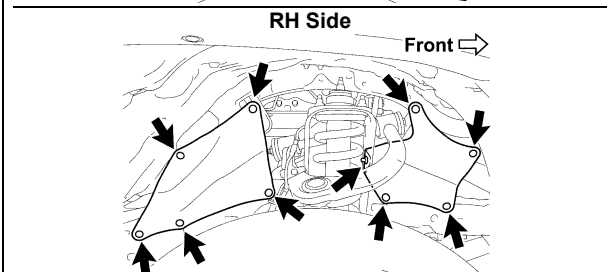
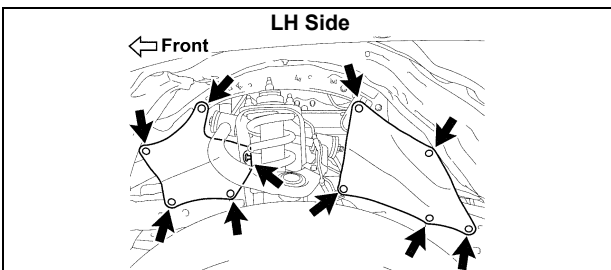
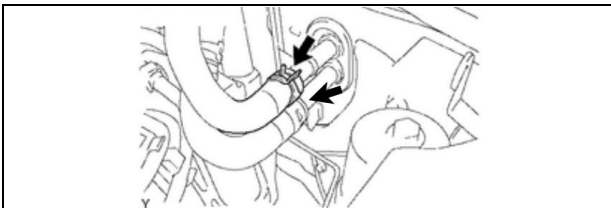
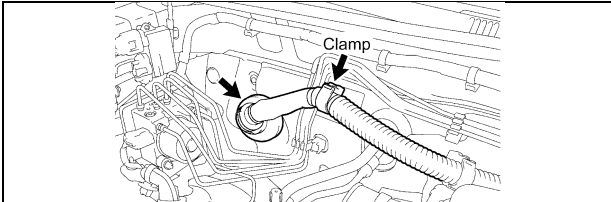
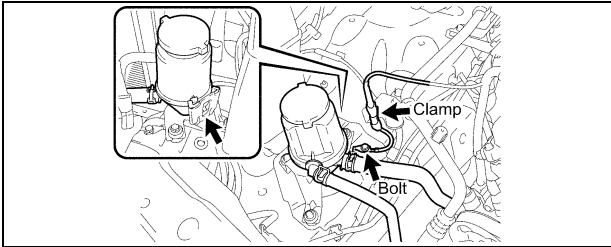
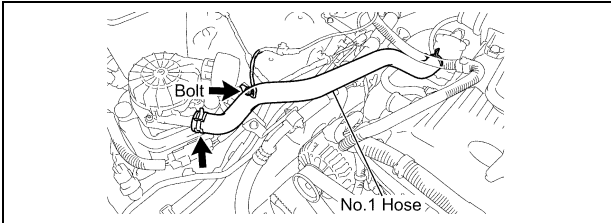

## 22. DISCONNECT THE NO.1 HOSE

2TR-FE Only (Shown):

- Disconnect the No.1 hose from the air pump Assy.
- Remove the bolt and disconnect the ground wire.

2012-2015MY (1GR-FE Only):

- Disconnect the No.1 hose from the air pump Assy.

## 23. DISCONNECT THE POWER STEERING PUMP OIL RESERVOIR ASSY (1GR-FE ONLY)

- Disconnect power steering pump oil reservoir Assy.

## 24. DISCONNECT THE GROUND WIRE (1GR-FE ONLY)

- Remove the bolt and disconnect the clamp and the ground wire.

## 25. DISCONNECT THE ENGINE WIRE HARNESS

- Disconnect the clamp.
- Remove the engine wire harness container from the cowl panel.

## 26. DISCONNECT THE WATER / HEATER HOSES, ENGINE SIDE

## 27. REMOVE THE FRONT FENDER APRON SEALS

4WD, Pre-Runner Only (Shown):

- Remove the 20 clips and 4 front fender apron seals.

2WD Only:

- Remove the 22 clips and 4 front fender apron seals.

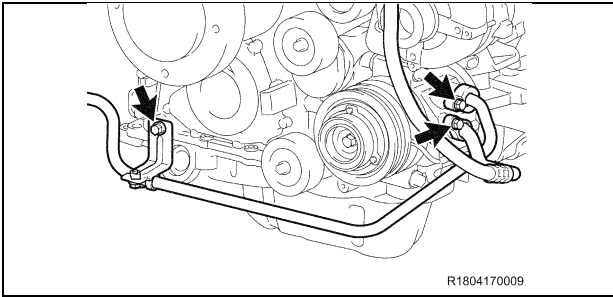

**28. DISCONNECT THE AIR CONDITIONING DISCHARGE AND SUCTION HOSES FROM THE COMPRESSOR**

**29. DISCONNECT THE SUCTION HOSE BRACKET**

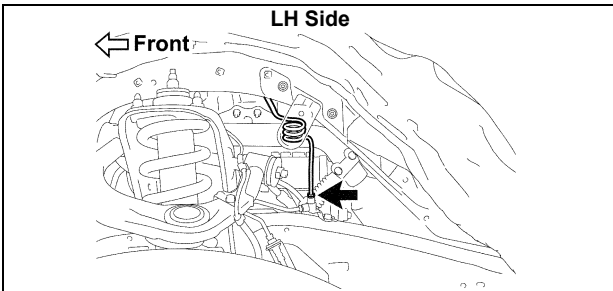

**30. DISCONNECT THE FRONT BRAKE TUBES**

- a) Disconnect the front brake tube.
- b) Repeat the procedure on the opposite side.

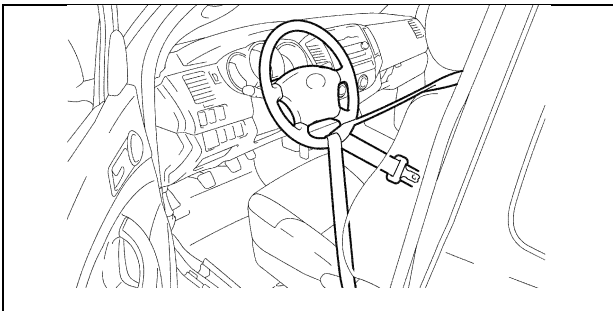
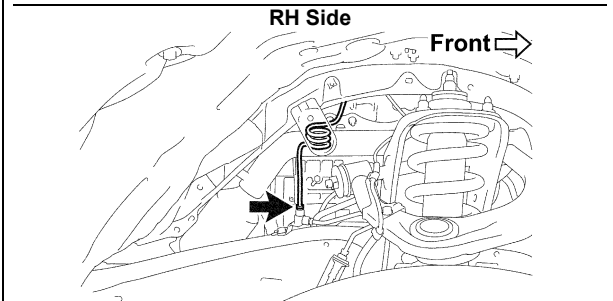

**31. DISCONNECT THE STEERING SLIDING YOKE**

**NOTE: Use precaution when performing this step, as you will need to work underneath the vehicle.**

- a) Make sure the front wheels are in a straight-ahead position and the steering wheel is centered.
- b) Using the seat belt, hold the steering wheel in position as shown in the illustration, to prevent damage to the spiral cable.
- c) Place match marks on the steering sliding yoke and No.2 intermediate shaft.
- d) Loosen bolt (A) and remove bolt (B).
- e) Disconnect the steering sliding yoke from the No.2 intermediate shaft.

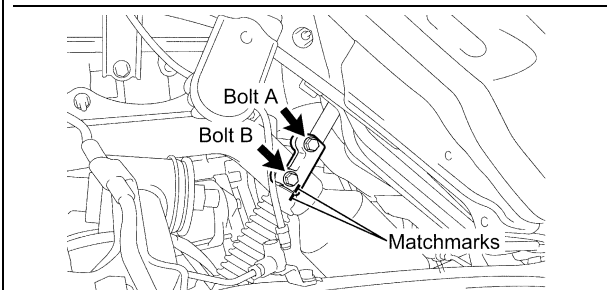

**NOTE: If the steering sliding yoke is stuck, tap it from below with a brass hammer to disconnect it.**

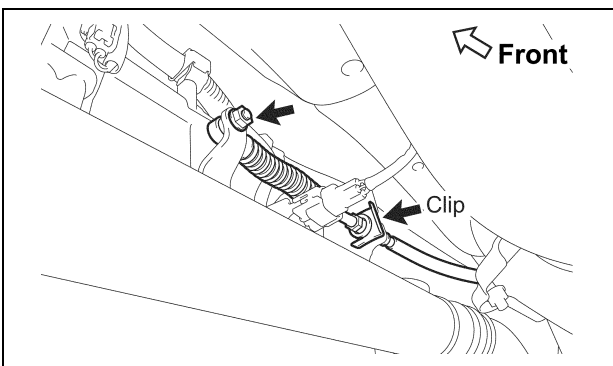

**32. DISCONNECT THE SHIFT CABLE (AUTO TRANS ONLY)**

**Cable Type (Shown):**

- a) Remove the clip.
- b) Remove the nut and disconnect the shift cable.

**Rod Type:**

- c) Remove the pin and clip, disconnect the shift cable.

**NOTE: Use precaution when performing this step, as you will need to work underneath the vehicle.**

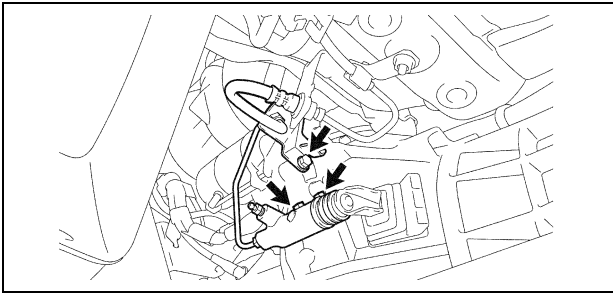

**33. DISCONNECT THE CLUTCH RELEASE CYLINDER ASSY**  
(2TR -FE MANUAL TRANS ONLY)

- a) Remove the bolt and disconnect the clutch hose.
- b) Remove the 2 bolts and disconnect the clutch release cylinder.

**NOTE:** Use precaution when performing this step, as you will need to work underneath the vehicle.

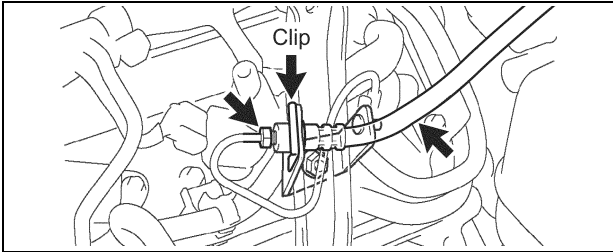

**34. DISCONNECT THE NO.1 CLUTCH HOSE**  
(1GR-FE MANUAL TRANS ONLY)

- a) Disconnect the clutch release cylinder tube from the clutch hose.
- b) Remove the clip and disconnect the clutch hose.

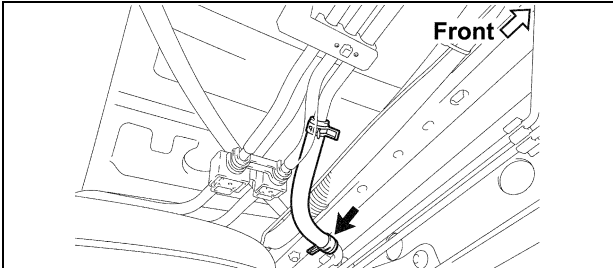

**35. DISCONNECT THE NO.2 FUEL HOSE**

- a) Remove the clip and disconnect the No.2 fuel hose.

**NOTE:** Use precaution when performing this step, as you will need to work underneath the vehicle.

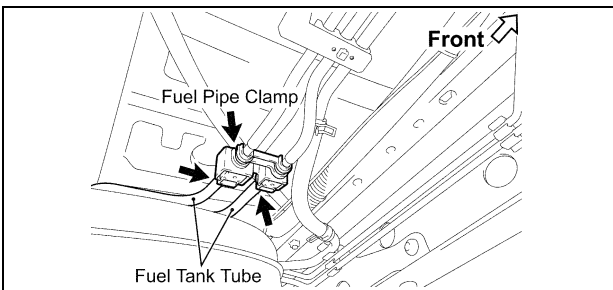

**36. DISCONNECT THE FUEL TANK TUBES**

- a) Remove the fuel pipe clamp.
- b) Disconnect the 2 fuel tank tubes.

**NOTE:** Use precaution when performing this step, as you will need to work underneath the vehicle.

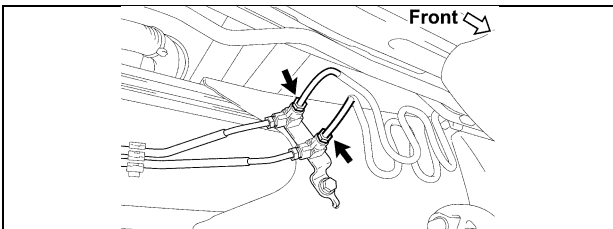

**37. DISCONNECT THE REAR BRAKE TUBES**

- a) Disconnect the 2 rear brake tubes.

**NOTE:** Use precaution when performing this step, as you will need to work underneath the vehicle.

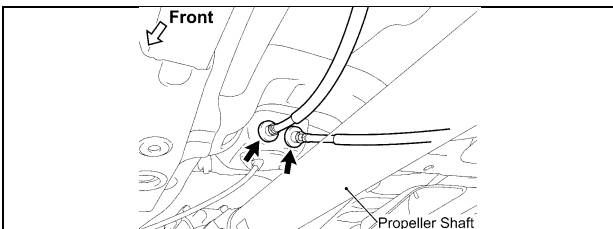

**38. DISCONNECT THE PARKING BRAKE CABLES**

**NOTE:** Use precaution when performing this step, as you will need to work underneath the vehicle.

**39. REMOVE THE FOLLOWING PARTS** (ACCESS CAB ONLY)

- Floor Board No.1/No.2
- Seat Floor Box
- Rear Floor Side Service Hole Cover LH/RH)
- Rear Lower Console Box
- Rear Seat Cushion Assy
- No.1 w/ Box Speaker Assy (If Equipped)

#### 40. REMOVE THE CAB BODY ASSY USING AN ABOVE GROUND LIFT

- a) Remove the 4 hole plugs.
- b) Remove the 6 nuts, 6 washers and 6 bolts.
- c) Set the lift arms under the cab body assy so they **DO NOT** interfere with the frame or cab mounts.
- d) Check that all wire harnesses, hoses, cables and the steering shaft are disconnected.
- e) Mark the location of the tires so it will be easier to install the cab onto the new frame.
- f) Lift the cab assy up slowly, making sure it does not interfere with anything while being raised.
- g) Raise the cab assy high enough so that the top of the engine clears the lowest point of the cab assy.
- h) Pull the frame assy out from under the vehicle.
- i) Lower the cab assy all the way down and leave it on the lift.
- j) Reinstall the 6 bolts, they will be used as guides during cab assy reinstallation.

#### NOTE:

- Center the cab assy weight on the lift arms so that it does not slant/tilt to one side.
- Raise the cab assy slightly off the frame and verify that it is held securely by the lift arms.
- The center of gravity of the cab body may become nose heavy depending on placement of the lift arm which could cause the cab to fall when lifted. To prevent this, use weights to establish a balance and secure the cab body to the lift arm using ratchet tie down belts.
- **DO NOT** work directly underneath the vehicle when pulling the frame assy out from under.

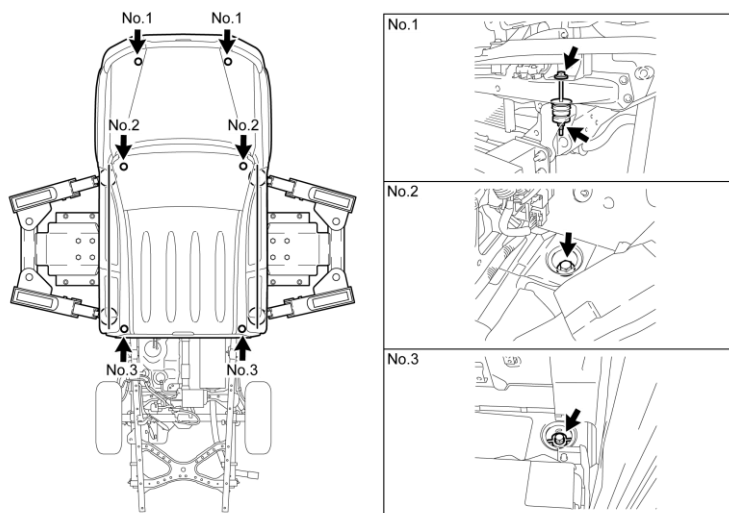

#### F. DISASSEMBLE THE FRAME

##### 1. PLACE THE FRAME ON A LIFT

- a) Place the frame on the lift, and secure it with a ratcheting tie down strap. This will prevent the frame from tilting or falling off as parts are removed.

- **Ratcheting Tie Downs: Qty 1 (Length: 2 in X 27 ft and Min. Work Load Capacity: 3,000 lbs)**

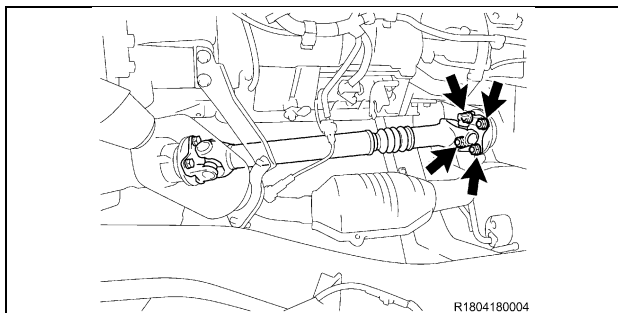

##### 2. DISCONNECT THE FRONT PROPELLER SHAFT ASSY (4WD ONLY)

- a) Remove the 4 nuts from transfer case side of the front propeller shaft assy.

##### 3. REMOVE THE FOLLOWING PARTS

- Wheels
- Rear Propeller Shaft Assy
- Insert **SST 09325-40010** into trans after the Rear Prop Shaft is removed to prevent oil leakage (2WD Only)
- Propeller Shaft Heat Insulator (If Equipped)
- Exhaust Pipe Stopper Bracket (If Equipped)

**NOTE: Place match marks on the front (if equipped) and rear propeller shafts prior to removal.**

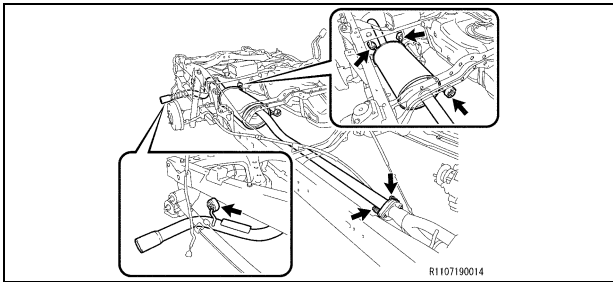

#### 4. REMOVE THE EXHAUST SYSTEM (1GR-FE ONLY)

- a) Remove the 2 bolts and 2 springs.
- b) Disconnect the 4 exhaust pipe supports from the frame and remove the center exhaust pipe assembly.
- c) Remove the exhaust pipe gasket.
- d) Disconnect the 2 exhaust pipe supports from the frame.

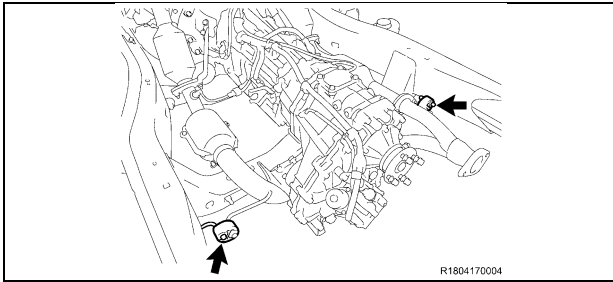

#### 5. REMOVE THE EXHAUST SYSTEM (2TR-FE ONLY)

- a) Remove the 2 bolts and 2 nuts.
- b) Disconnect the 4 exhaust pipe supports from the frame and remove the center exhaust pipe assembly.
- c) Remove the exhaust pipe gasket.
- d) Disconnect the 2 oxygen sensor wire harness clamps.
- e) Disconnect the exhaust pipe support from the frame.

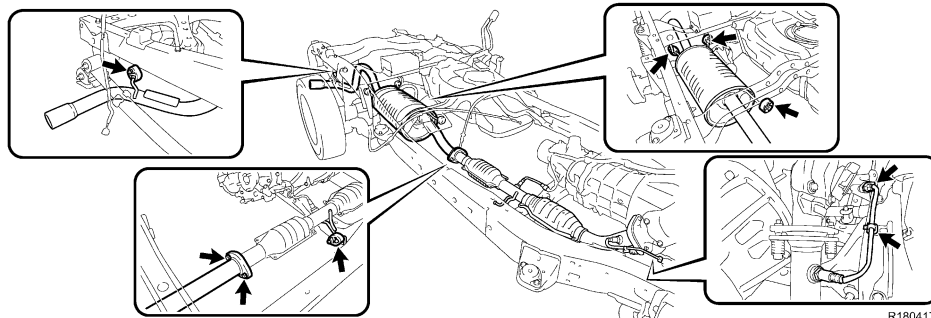

#### 6. REMOVE THE FOLLOWING PARTS

- No.2 Fuel Tank Protector (If Equipped)
- No.1 Fuel Tank Protector Assy (If Equipped)
- Fuel Tank Straps
- V-belt
- Fuel Tank
- Charcoal Canister Assy

#### 7. REMOVE AND SET ASIDE THE POWER STEERING VANE PUMP

- a) Disconnect the connector.
- b) Disconnect the clamp. (1GR-FE Only)
- c) Remove the bolt and disconnect the ground wire. (1GR-FE Only)
- d) Remove the 2 bolts and the power steering vane pump.

**NOTE:**

- DO NOT disconnect the power steering vane pump hoses or tubes.
- Keep the power steering pump reservoir upright to prevent the fluid from leaking out.

#### 8. REMOVE THE FOLLOWING PARTS

- Intake Air Surge Tank (1GR-FE Only)
- Intake Air Connector (2TR-FE Only)

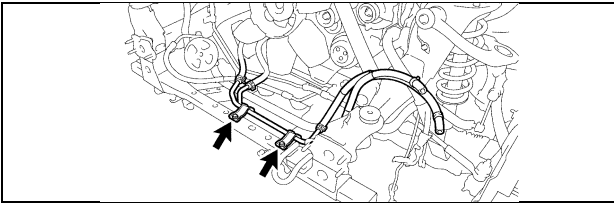

**9. DISCONNECT THE OIL COOLER TUBE (AUTO TRANS ONLY)**

- a) Remove the bolts and disconnect the oil cooler tube.

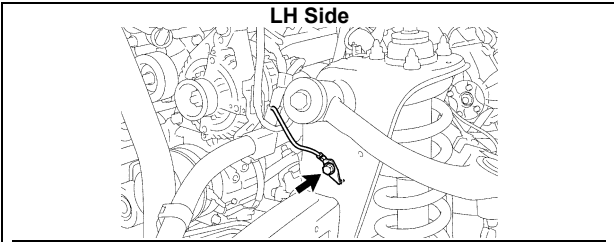

**10. REMOVE THE ENGINE AND TRANSMISSION ASSY**

- a) Remove the bolt and disconnect the ground wire. *(LH Side)*  
 b) Disconnect the connector and clamp. *(4WD Only)*  
 c) Disconnect the clamp. *(2TR-FE Only)*  
 d) Disconnect and remove the necessary items/parts to prepare the engine and transmission assy for removal.  
 e) Install the engine hanger.

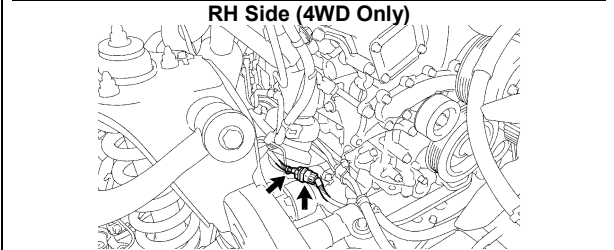

**For 1GR-FE:**

**12281-31060 = No.1 Engine Hanger**

**12282-31040 = No.2 Engine Hanger**

**90119-08A87 = 4 Bolts**

**For 2TR-FE:**

**12281-75050 = 2 Engine Hangers**

**91672-81025 = 2 Bolts**

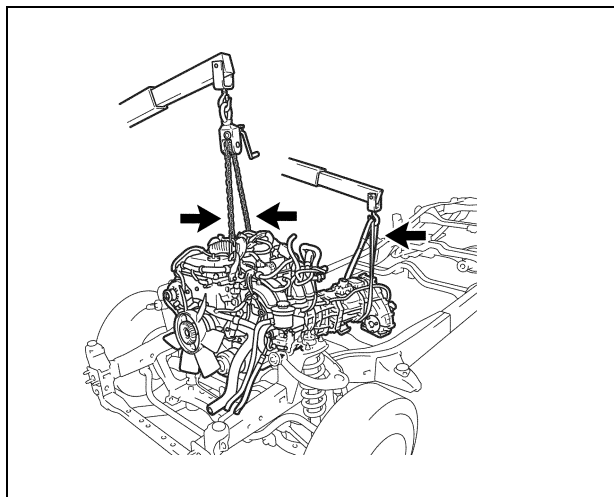
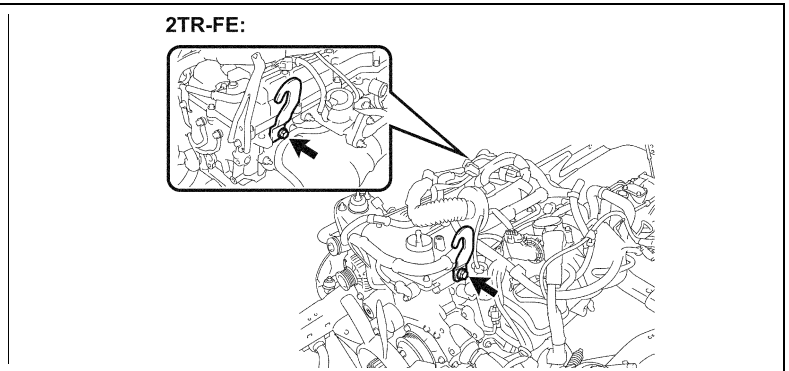
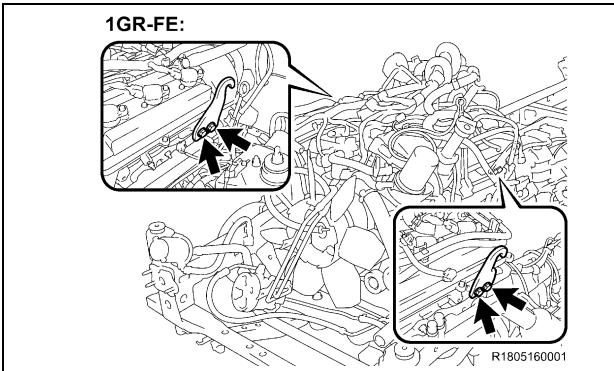
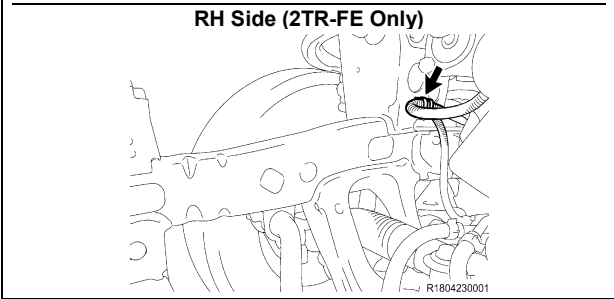

- f) Remove the engine and transmission assy.

**NOTE:**

- Hang up the front exhaust pipe with string to avoid applying pressure at the joint part. *(2TR-FE only)*
- ALWAYS use 2 engine hoists/cranes to lift it.
- DO NOT use 1 engine hoist/crane to lift the engine & transmission assy, as the unbalanced weight may lead to an accident or injury.
- ONLY use engine hoists/cranes that can properly support the weight of the engine and transmission assy.
- Carefully adjust the 2 engine hoists/cranes used so that the engine and transmission assy is properly balanced.



Be careful not to damage exhaust system while removing the engine and trans mission assy.

### 11. REMOVE THE FRONT PROPELLER SHAFT ASSY (4WD ONLY)

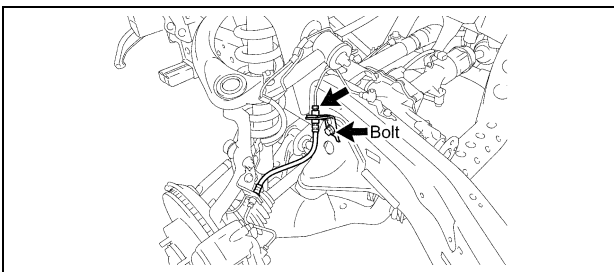
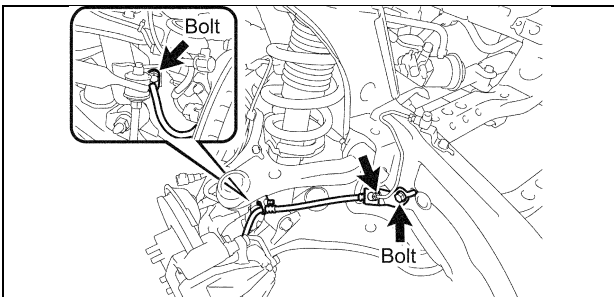
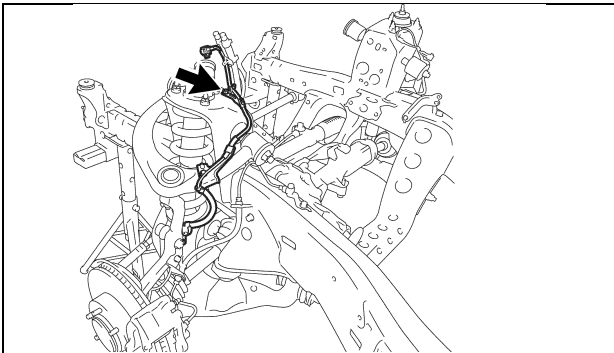
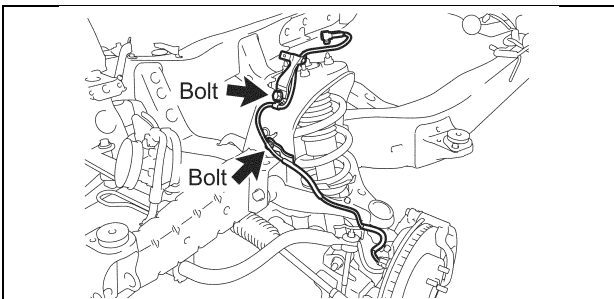
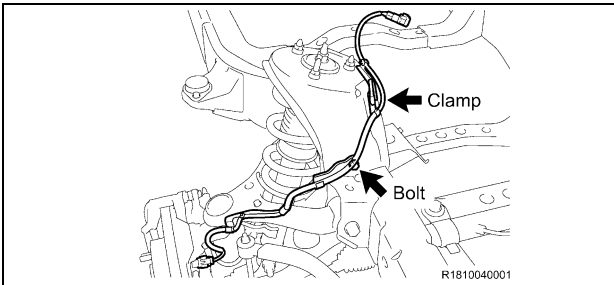

### 16. REMOVE THE FOLLOWING PARTS

- Front Axle Hub Grease Cap (4WD Only)
- Front Axle Shaft Nut (4WD Only)
- Tie Rod End\*
- Front Stabilizer Link Assy
- Lower Ball Joint Attachment\*\*

### 12. DISCONNECT THE FRONT SKID CONTROL SENSOR WIRE HARNESS (2WD ONLY)

#### 2011MY RH Side:

- a) Remove the bolt, disconnect the clamp and skid control sensor wire harness.

#### Except 2011MY RH Side:

- b) Remove the 2 bolts and skid control sensor wire harness.
- c) Repeat the procedure on the opposite side.

### 13. DISCONNECT THE FRONT SKID CONTROL SENSOR WIRE HARNESS (4WD, PRE-RUNNER ONLY)

- a) Remove the bolt and disconnect the skid control sensor wire harness.
- b) Repeat the procedure on the opposite side.

### 14. DISCONNECT THE FRONT BRAKE HOSE (2WD ONLY)

- a) Disconnect the front brake tube from the brake hose.
- b) Remove the 2 bolts and disconnect the front brake hose and flexible hose bracket.
- c) Repeat the procedure on the opposite side.

### 15. DISCONNECT THE FRONT BRAKE HOSE (4WD, PRE-RUNNER ONLY)

- a) Disconnect the front brake tube from the brake hose.
- b) Remove the bolt and disconnect the front brake hose and flexible hose bracket.
- c) Repeat the procedure on the opposite side.



\* SST 09610-20012 (2WD), SST 09628-62011 (4WD, Pre-Runner) disconnect the tie rod end.

\*\*SST 09628-00011

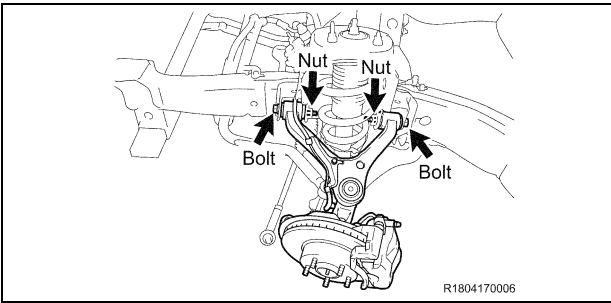

**17. REMOVE THE FRONT SUSPENSION UPPER ARM AND STEERING KNUCKLE ASSY (2WD ONLY)**

- a) Remove the 2 bolts, 2 nuts, 2 washers and front suspension upper arm w/ steering knuckle.
- b) Repeat the procedure on the opposite side.

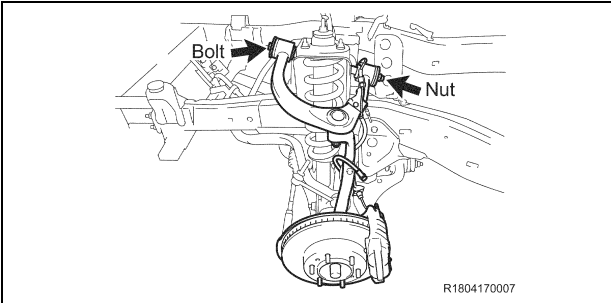

**18. REMOVE THE FRONT SUSPENSION UPPER ARM AND STEERING KNUCKLE ASSY (4WD, PRE-RUNNER ONLY)**

- a) Remove the bolt, nut, 2 washers and front suspension upper arm w/ steering knuckle.
- b) Repeat the procedure on the opposite side.

**NOTE: If the drive shaft is difficult to disconnect, tap the drive shaft loose with a plastic hammer.**

**19. REMOVE THE FOLLOWING PARTS**

- Front Drive Shaft Assy (4WD Only) \*
- Front Suspension Member Brace Sub-Assy
- Front Stabilizer Bar
- Front Shock Absorber Assy
- Power Steering Link Assy w/ Pump
- Front Differential Carrier (4WD Only)

\*SST 09520-24010 (09520-32040), 09520-01010

**NOTE:**

- When removing the power steering link with the pump, have one person support the power steering link and the other support the pump and keep it upright to avoid fluid leakage.
- If the drive shaft is difficult to remove tap it with a plastic hammer.
- Be careful not to damage the dust cover and oil seal.

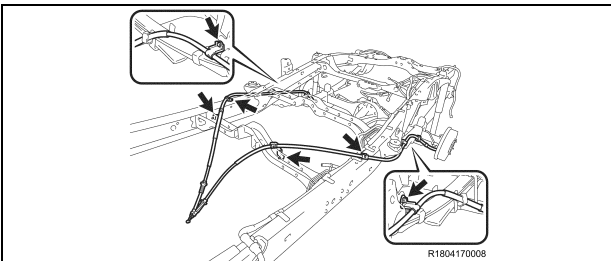

**20. DISCONNECT THE PARKING BRAKE CABLES**

- a) Remove the 6 bolts and parking brake cables.

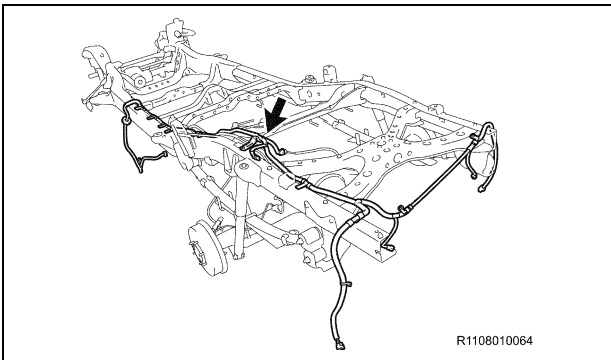

**21. REMOVE THE FRAME WIRE HARNESS**

- a) Remove the bolt and disconnect the ground wire (If Equipped).
- b) Disconnect the clamps and remove the frame wire harness.

**NOTE:**

- The number of wire harness clamps will differ depending on the vehicle specification.
- Take care not to damage or break the wire harness clamps during removal.

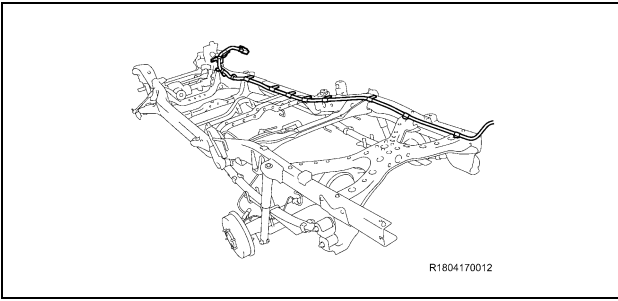

## 22. REMOVE THE NO.2 FRAME WIRE HARNESS (IF EQUIPPED)

- a) Disconnect the clamps and remove the frame wire harness.

### NOTE:

- The number of wire harness clamps will differ depending on the vehicle specification.
- Take care not to damage or break the wire harness clamps during removal.

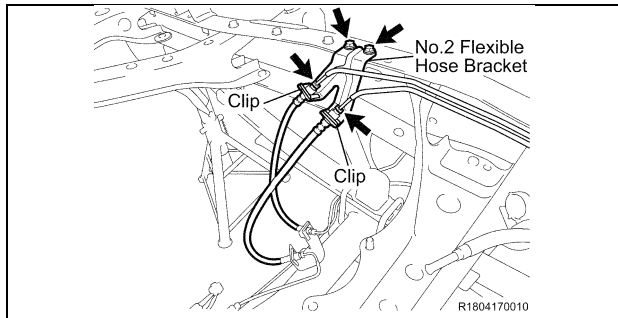

## 23. REMOVE THE NO.2 FLEXIBLE HOSE BRACKET

- a) Disconnect the No.5 rear brake tube.
- b) Disconnect the No.6 rear brake tube.
- c) Remove the 2 clips and disconnect the 2 brake hoses.
- d) Remove the 2 bolts and No.2 flexible hose bracket.

## 24. REMOVE THE FOLLOWING PARTS

- Spare Tire Carrier Assy (2012-2015MY)
- No.1 Rear Spring Bumper (2WD Only)
- Rear Stabilizer Bar (If Equipped)

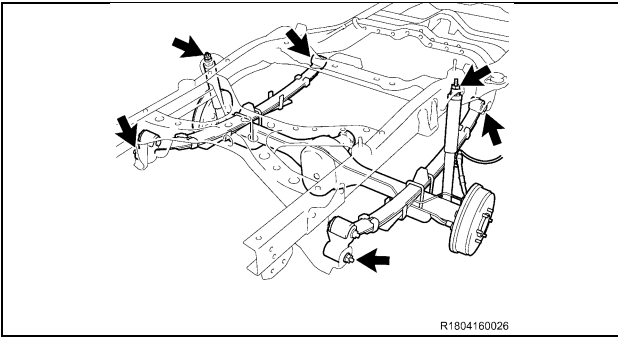

## 25. REMOVE THE LEAF SPRINGS AND SHOCK ABSORBER ASSY



For this campaign, the leaf springs will not be replaced. However, if eligible, replace leaf springs under E02. If the vehicle is not eligible for E02, or already had E02 performed, there is no need to separate the rear differential from the leaf springs, remove the leaf springs and rear diff as an assembly.

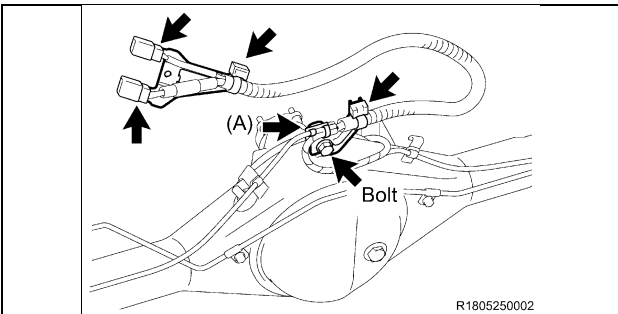

## 26. REMOVE THE SKID CONTROL SENSOR WIRE BRACKET (W/ REAR DIFFERENTIAL LOCK ONLY)

- a) Remove the bolt.
- b) Cut the clamp (A) using nippers.
- c) Disconnect the 2 clamps and 2 connectors to remove the 2 brackets.
- d) Remove the clamp (A) from the bracket.

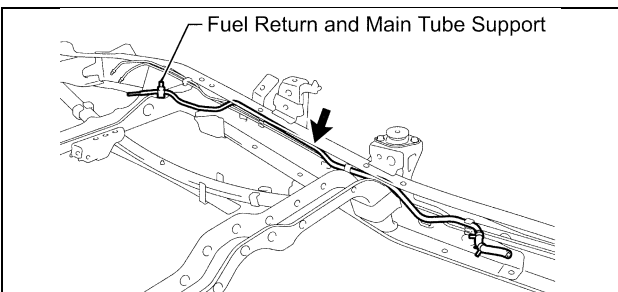

## 27. REMOVE THE NO.2 CHARCOAL CANISTER PIPE

- a) Disconnect the clamps and remove the No.2 charcoal canister pipe.

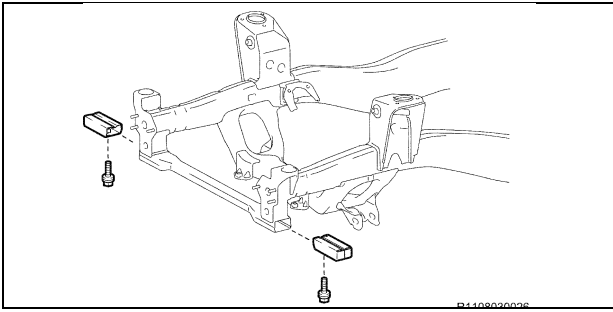

**28. REMOVE THE FRAME AUXILIARY CROSSMEMBER EXTENSIONS (IF EQUIPPED)**

- a) Remove the 2 bolts and frame auxiliary crossmember extensions.

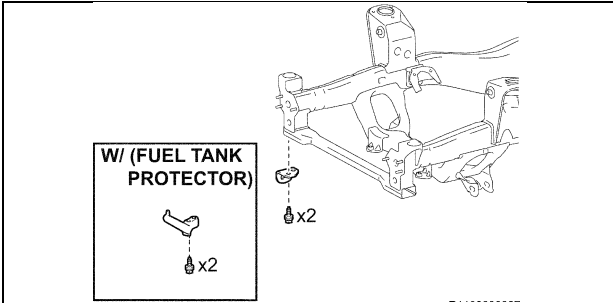

**29. REMOVE THE HOOK**

- a) Remove the 2 bolts and hook.

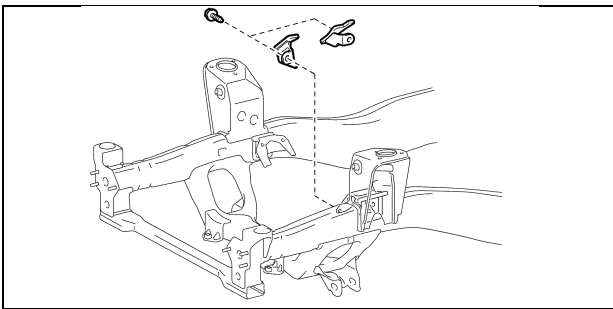

**30. REMOVE THE REAR ENGINE MOUNTING REINFORCES (1GR-FE ONLY)**

- a) Remove the 2 bolts and 2 rear engine mounting reinforces.

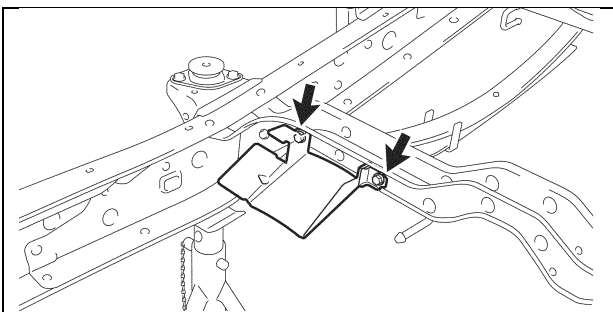

**31. REMOVE THE PARKING BRAKE CABLE HEAT INSULATOR (IF EQUIPPED)**

- a) Remove the 2 bolts and parking brake cable heat insulator.

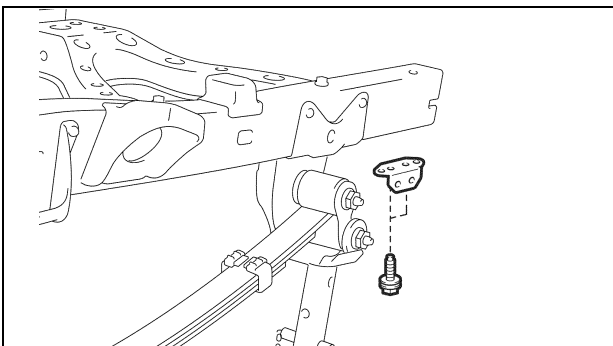

**32. REMOVE THE NO.1 RECEIVER HITCH ATTACHMENT REINFORCEMENT (IF EQUIPPED)**

- a) Remove the 2 bolts and No.1 receiver hitch attachment reinforcement.

**33. REMOVE THE CAB MOUNTS**

**34. REMOVE THE FRAME FROM THE LIFT**

- a) Remove the ratcheting tie down strap and the frame from the lift.

**G. PLUG HOLES IN REPLACEMENT FRAME (see Appendix)**

**1. PLACE THE *NEW* FRAME ON THE LIFT**

- a) Place the ***NEW*** frame on the lift, and secure it with a ratcheting tie down strap.
- **Ratcheting Tie Downs: Qty 1 (Length: 2 in X 27 ft and Min. Work Load Capacity: 3,000 lbs)**
- b) Install all plugs. Use the picture found in appendix to reference the plug installation.

**NOTE:**

- **You may have to remove certain stickers to install optional equipment.**
- **You may not install all the plugs in plug kit.**
- **Make sure all the plugs are flush with the frame.**
- **Make sure the surface of the frame is clean before you apply stickers.**

## H. ASSEMBLE THE FRAME

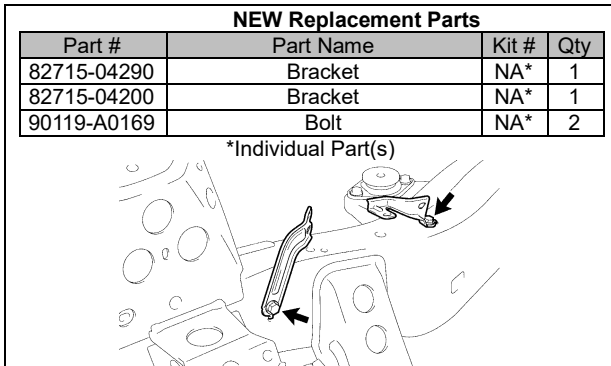
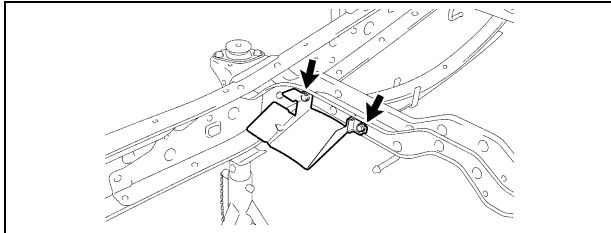
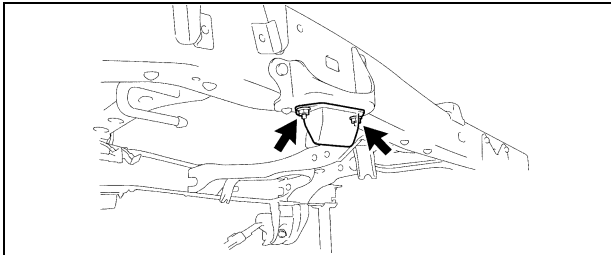
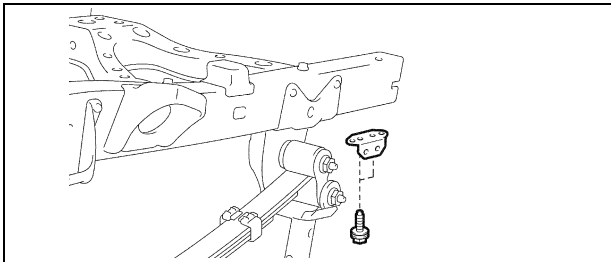
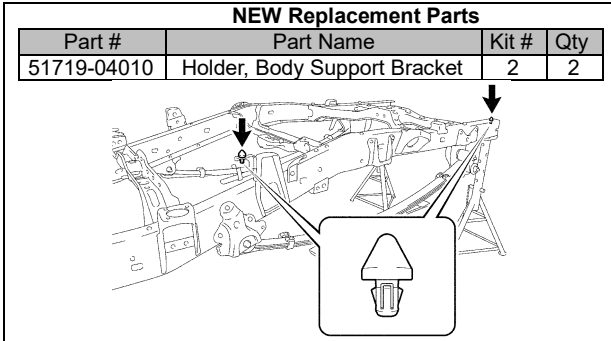

### 1. INSTALL THE *NEW* CLIPS

### 2. REINSTALL THE NO.1 RECEIVER HITCH ATTACHMENT REINFORCEMENT (IF EQUIPPED)

- a) Reinstall the No.1 receiver hitch attachment reinforcement with the 2 bolts and torque to spec.

**Torque Spec: 45 N·m (459 kgf·cm, 33 ft·lbf)**

- b) Repeat the procedure on the opposite side.

### 3. REINSTALL THE NO.1 REAR SPRING BUMPER (2WD ONLY)

- a) Reinstall the rear spring bumper with the 2 nuts and torque to spec.

**Torque Spec: 15 N·m (153 kgf·cm, 11 ft·lbf)**

- b) Repeat the procedure on the opposite side.

### 4. REINSTALL THE PARKING BRAKE CABLE HEAT INSULATOR (IF EQUIPPED)

- a) Reinstall the parking brake cable heat insulator with the 2 bolts and torque to spec.

**Torque Spec: 12.5 N·m (127 kgf·cm, 9 ft·lbf)**

### 5. INSTALL THE *NEW* OXYGEN SENSOR BRACKETS (2TR-FE ONLY)

- a) Install the 2 *NEW* brackets with the 2 *NEW* bolts and torque to spec.

**Torque Spec: 29 N·m (296 kgf·cm, 21 ft·lbf)**

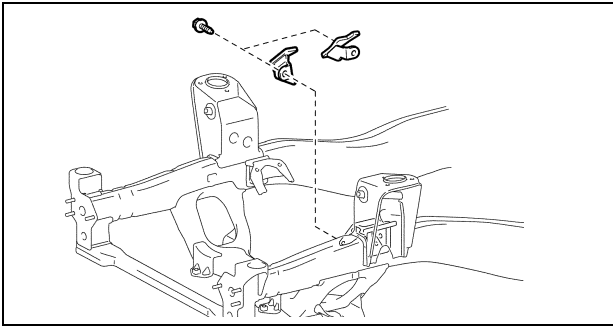

**6. REINSTALL THE REAR ENGINE MOUNTING REINFORCES (1GR-FE ONLY)**

- a) Reinstall the rear engine mounting reinforces with the 2 bolts and torque to spec.

**Torque Spec: 31 N·m (316 kgf·cm, 23 ft·lbf)**

**NEW Replacement Parts**

Part #	Part Name	Kit #	Qty
90119-A0192	Bolt	8	2
90119-A0193	Bolt	NA*	2

\*Individual Part(s)

**W/ (FUEL TANK PROTECTOR)**

x2

x2

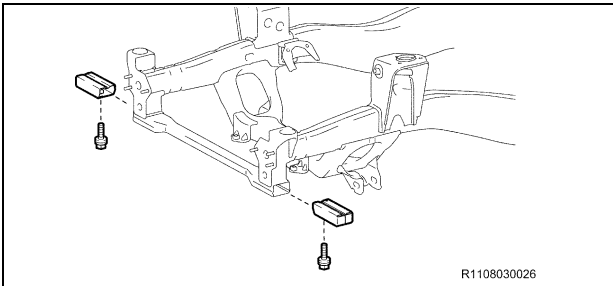

**8. REINSTALL THE FRAME AUXILIARY CROSSMEMBER EXTENSION (IF EQUIPPED)**

- a) Reinstall the 2 frame auxiliary crossmember extensions with the 2 bolts and torque to spec.

**Torque Spec: 45 N·m (459 kgf·cm, 33 ft·lbf)**

No.1

No.2

No.3

**9. REINSTALL THE CAB MOUNTS**

- a) Reinstall cab mounts No.1
- b) Reinstall cab mounts No.2 and No.3 with the 8 bolts and torque to spec.

**Torque Spec: 61 N·m (622 kgf·cm, 45 ft·lbf)**

**10. INSTALL THE NEW FRONT SUSPENSION LOWER ARM (2WD ONLY)**

- a) Install the **NEW** front suspension lower arm with the 2 **NEW** nuts, 2 **NEW** No.1 camber adjust cams and 2 **NEW** No.2 camber adjust cams, then torque to spec.

**Torque Spec: 210 N·m (2141 kgf·cm, 155 ft·lbf)**

- b) Repeat the procedure on the opposite side.

**NEW Replacement Parts**

Part #	Part Name	Kit #	Qty
48069-04030	Arm Sub-Assy, Front Suspension, Lower No.1, LH	NA*	1
48068-04030	Arm Sub-Assy, Front Suspension, Lower No.1, RH	NA*	1
48190-25010	Cam, Front Suspension Camber Adjust, No.1 LH/RH	4	4
48198-25010	Cam, Front Suspension Camber Adjust, No.2 LH/RH	4	4
90178-A0013	Nut	NA*	4

\*Individual Part(s)

2WD Only

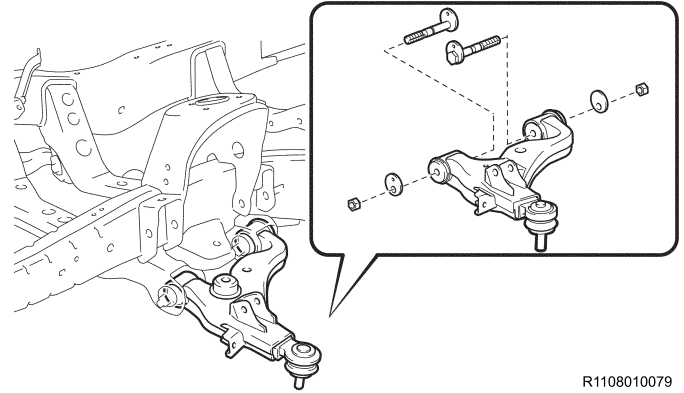

R1108010079

**11. INSTALL THE NEW FRONT SUSPENSION LOWER ARM (4WD, PRE-RUNNER ONLY)**

- a) Install the **NEW** front suspension lower arm with the **NEW** bolt, **NEW** nut, **NEW** toe adjust cam, **NEW** No.2 toe adjust cam, **NEW** No.1 camber adjust cam and **NEW** No.2 camber adjust cam, then torque to spec.

**Torque Spec: 135 N·m (1377 kgf·cm, 100 ft·lbf)**

- b) Repeat the procedure on the opposite side.

**NEW Replacement Parts**

Part #	Part Name	Kit #	Qty
48069-04040	Arm Sub-Assy, Front Suspension, Lower No.1, LH	NA*	1
48068-04040	Arm Sub-Assy, Front Suspension, Lower No.1, RH	NA*	1
48190-60020	Cam, Front Suspension Camber Adjust, No.1 LH/RH	5	2
48198-60011	Cam, Front Suspension Camber Adjust, No.2 LH/RH	5	2
48409-60020	Cam, Sub-Assy, Front Suspension Toe Adjust	5	2
48452-35020	Plate, Front Suspension Toe Adjust, No.2	5	2
90119-A0166	Bolt	8	2
90178-A0001	Nut	NA*	2

\*Individual Part(s)

4WD, Pre-Runner Only

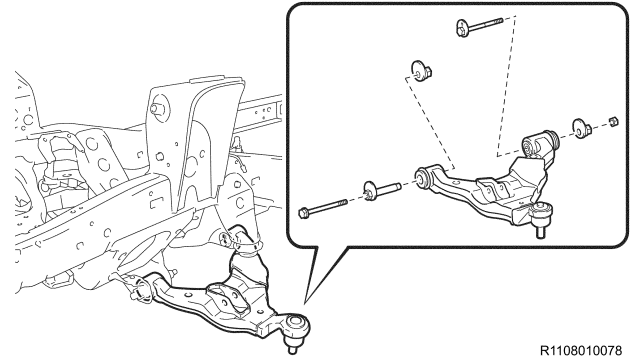

R1108010078

**NEW Replacement Parts (2WD Only)**

Part #	Part Name	Kit #	Qty
48304-AD010	Bumper, Front Spring, LH/RH**	NA*	2
48304-04090		NA*	2

\*Individual Part(s)

\*\*Only 1 part used, part number varies by vehicle type.

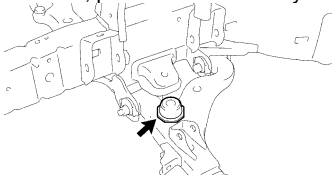

**NEW Replacement Parts (4WD, Pre-Runner Only)**

Part #	Part Name	Kit #	Qty
48304-04100	Bumper, Front Spring, LH/RH	8	2

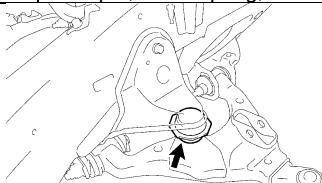

**12. INSTALL THE NEW FRONT SPRING BUMPER**

- a) Using the SST **09922-10010-01**, install the **NEW** front spring bumpers and torque to spec.

**Torque Spec: 31 N·m (316 kgf·cm, 23 ft·lbf)**

- b) Repeat the procedure on the opposite side.

**13. INSTALL THE NEW REAR BRAKE TUBES**

- a) Install the **NEW** rear brake tubes with the **NEW** clamp(s).

**NEW Replacement Parts**

Part #	Part Name	Kit #	Qty
47325-****	Tube, Rear Brake, No.5	NA*	1
47326-****	Tube, Rear Brake, No.6	NA*	1
90469-A0004	Clamp, Brake Tube, No.11**	NA*	2
		NA*	3
		NA*	4
90949-A1006	Clamp, Brake Tube, No.10	2	3

\*Individual Part(s)

\*\* Only 1 part used, part number varies by vehicle type.

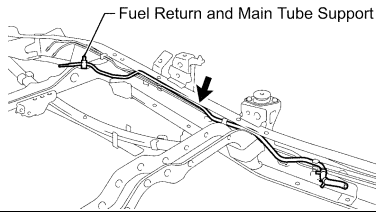
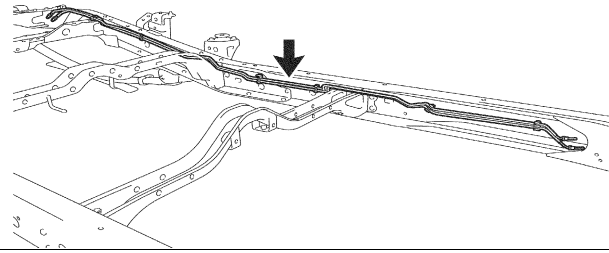

**14. REINSTALL THE NO. 2 CHARCOAL CANISTER PIPE**

- a) Reinstall the fuel return and main tube support.
- b) Reinstall the No.2 charcoal canister pipe.

**NEW Replacement Parts**

Part #	Part Name	Kit #	Qty
90119-A0169	Bolt	2	4
51900-35410	Carrier Assy, Spare Wheel**	NA*	1
51900-35420		NA*	1

\*Individual Part(s)

\*\* Only 1 part used, part number varies by vehicle type.

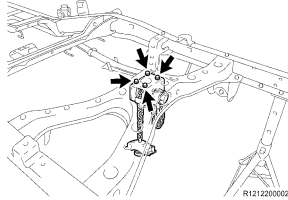

**15. INSTALL THE NEW SPARE TIRE CARRIER ASSY (2011MY ONLY)**

- a) Install the **NEW** spare tire carrier assy with the 4 **NEW** bolts and torque to spec.

**Torque Spec: 20 N·m (204 kgf·cm, 15 ft·lbf)**

**16. REINSTALL THE SPARE TIRE CARRIER ASSY (2012-2015MY ONLY)**

- a) Reinstall the spare tire carrier assy with the 4 **NEW** bolts and torque to spec.

**Torque Spec: 20 N·m (204 kgf·cm, 15 ft·lbf)**

**NEW Replacement Parts**

Part #	Part Name	Kit #	Qty
82715-04250	Bracket	NA*	1
82715-04260	Bracket	NA*	1
82711-16830	Clamp	NA*	1
90105-A0066	Bolt	NA*	1

\*Individual Part(s)

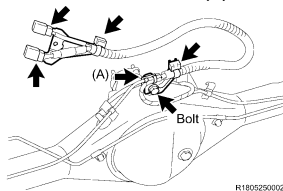

**17. INSTALL THE NEW SKID CONTROL SENSOR WIRE BRACKET (W/ REAR DIFFERENTIAL LOCK ONLY)**

- a) Install the **NEW** clamp (A).
- b) Install the 2 **NEW** brackets with the 2 clamps and 2 connectors.
- c) Install the **NEW** bolt.

**Torque Spec: 12.5 N·m (127 kgf·cm, 9 ft·lbf)**

**NEW Replacement Parts**

Part #	Part Name	Kit #	Qty
90177-A0010	Nut	2	2

\*Individual Part(s)

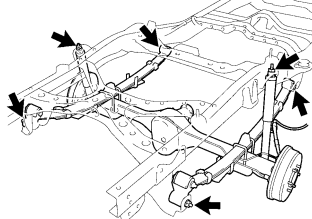

**18. REINSTALL THE LEAF SPRINGS AND SHOCK ABSORBER ASSY**

- a) Reinstall the leaf springs with the 4 bolts, 4 washers and 4 nuts, then torque to spec.

**Torque Spec: 120 N·m (1224 kgf·cm, 89 ft·lbf)**

- b) Reinstall the shock absorber assy with the 2 **NEW** nuts, 2 retainers and 2 cushions, then torque to spec.

**Torque Spec: 20 N·m (204 kgf·cm, 15 ft·lbf)**



NEW Replacement Parts			
Part #	Part Name	Kit #	Qty
90119-08A91	Bolt	NA*	4

\*Individual Part(s)

NEW Replacement Parts			
Part #	Part Name	Kit #	Qty
90468-A0007	Clip	2	2
90119-A0169	Bolt	14 or 15 or NA*	2

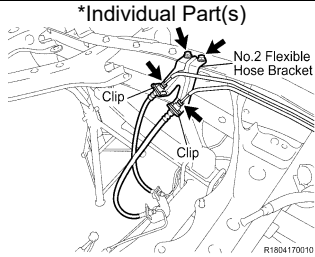

NEW Replacement Parts			
Part #	Part Name	Kit #	Qty
82715-04200	Bracket	NA*	1
82715-04290	Bracket	NA*	1
82715-04240	Bracket	NA*	1
82715-04350	Bracket	NA*	1
90119-A0169	Bolt	NA*	4

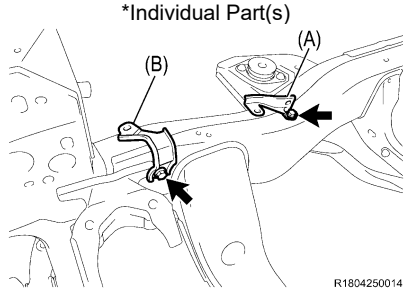

Rear Side  
(Floor Connecting Type)

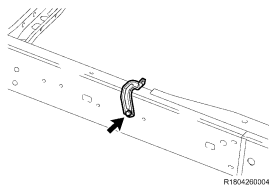

Rear Side  
(Frame Connecting Type)

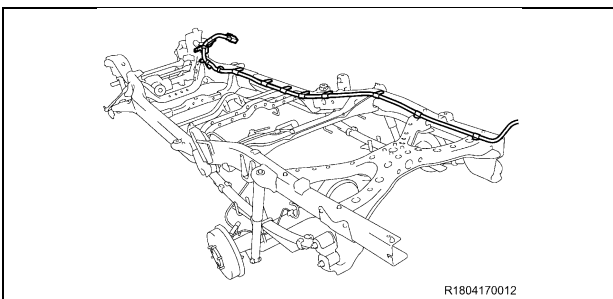
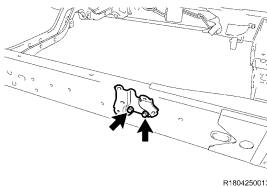

NEW Replacement Parts			
Part #	Part Name	Kit #	Qty
82715-04220	Bracket	NA*	1

### 19. REINSTALL THE REAR STABILIZER BAR (IF EQUIPPED)

- a) Reinstall the rear stabilizer bar with the 2 brackets and 4 **NEW** bolts, then torque to spec.

**Torque Spec: 30 N·m (306 kgf·cm, 22 ft·lbf)**

- b) Reconnect the 2 stabilizer bar links with the 4 nuts, then torque to spec.

**Torque Spec: 65 N·m (663 kgf·cm, 48 ft·lbf)**

### 20. REINSTALL THE NO.2 FLEXIBLE HOSE BRACKET

- a) Reinstall the No.2 flexible hose bracket with the 2 **NEW** bolts.
- b) Reconnect the 2 brake hoses with the 2 **NEW** clips.
- c) Connect the No.5 and No.6 rear brake tubes, then torque to spec.

**Torque Spec:**

**Flexible hose bracket - 29 N·m (296 kgf·cm, 21 ft·lbf)**

**Rear brake tube - 15.2 N·m (155 kgf·cm, 11 ft·lbf)**

### 21. INSTALL THE NEW NO.2 FRAME WIRE HARNESS BRACKETS (IF EQUIPPED)

- a) Install the **NEW** bracket (A) with the **NEW** bolt and torque to spec. *(Except 2TR-FE)*

**Torque Spec: 29 N·m (296 kgf·cm, 21 ft·lbf)**

- b) Install the **NEW** bracket (B) with the **NEW** bolt and torque to spec. *(Except 2TR-FE)*

**Torque Spec: 29 N·m (296 kgf·cm, 21 ft·lbf)**

**For Floor Connecting Type:**

- c) Install the **NEW** bracket with the **NEW** bolt and torque to spec.

**Torque Spec: 29 N·m (296 kgf·cm, 21 ft·lbf)**

**For Frame Connecting Type:**

- d) Install the **NEW** bracket with the 2 **NEW** bolts and torque to spec.

**Torque Spec: 29 N·m (296 kgf·cm, 21 ft·lbf)**

### 22. REINSTALL THE NO.2 FRAME WIRE HARNESS (IF EQUIPPED)

- a) Reconnect the clamps to install the No.2 frame wire harness.

**NOTE: The number of wire harness clamps will differ depending on the vehicle spec.**

### 23. INSTALL THE NEW HARNESS BRACKETS

82715-04230	Bracket	NA*	1
90119-A0169	Bolt	NA*	2

\*Individual Part(s)

Front Side

Rear Side

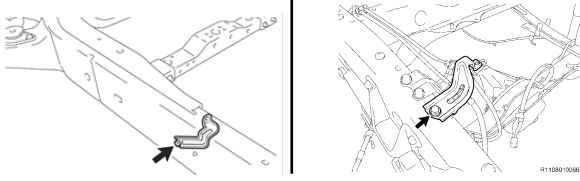

- a) Install the 2 **NEW** brackets with the 2 **NEW** bolts and torque to spec.

**Torque Spec: 14 N·m (143 kgf·cm, 10 ft·lbf)**

#### 24. REINSTALL THE FRAME WIRE HARNESS

- a) Reconnect the clamps to install the frame wire harness.  
 b) Reconnect the ground wire with the bolt and torque to spec (If Equipped).

**Torque Spec: 14 N·m (143 kgf·cm, 10 ft·lbf)**

**NOTE: The number of wire harness clamps will differ depending on the vehicle spec.**

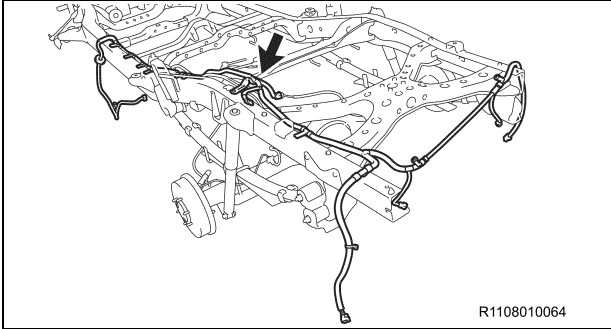

#### 25. RECONNECT THE PARKING BRAKE CABLES

- a) Reinstall the 2 parking brake cables with the 6 bolts, then torque to spec.

**Torque Spec: 12.5 N·m (127 kgf·cm, 9 ft·lbf)**

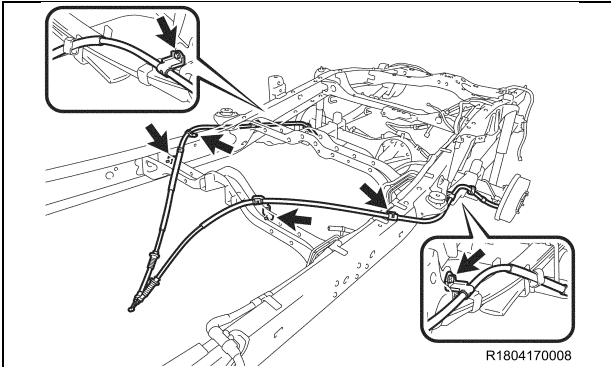

#### Access Cab Parking Brake Cable Routing

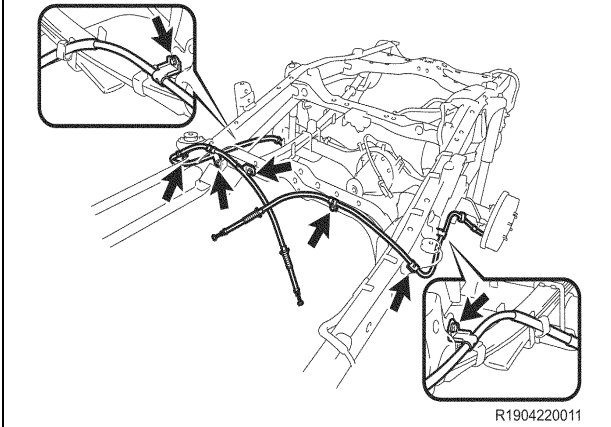

**NEW Replacement Parts**

Part #	Part Name	Kit #	Qty
82715-04160	Bracket**	NA*	1
82715-3D680		NA*	1
90119-A0141	Bolt	NA*	1

\*Individual Part(s)

\*\* Only 1 part used, part number varies by vehicle type.

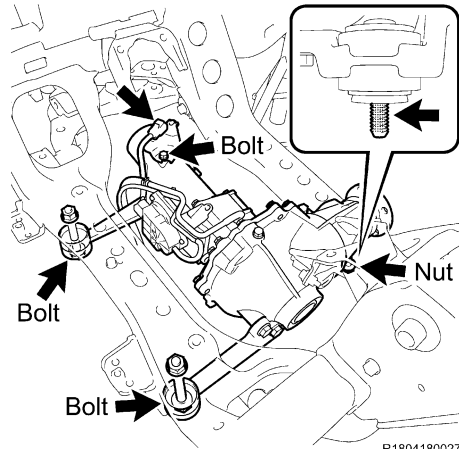

**26. REINSTALL THE FRONT DIFFERENTIAL CARRIER (4WD ONLY)**

- Apply adhesive to the serration bolt.
- Reinstall the front differential carrier with the 2 bolts, 4 stoppers and 3 nuts, then torque to spec.

**Torque Spec: Except TMMTX Made**

**Bolt - 137.3 N·m (1400 kgf·cm, 101 ft·lbf)**

**Nut - 87.2 N·m (889 kgf·cm, 64 ft·lbf)**

**Torque Spec: TMMTX Made**

**Bolt - 128.5 N·m (1310 kgf·cm, 95 ft·lbf)**

**Nut - 81.5 N·m (831 kgf·cm, 60 ft·lbf)**

- Disconnect the connector from the bracket.
- Remove the bolt and bracket.
- Install the **NEW** bracket with the **NEW** bolt and torque to spec.

**Torque Spec: 14 N·m (143 kgf·cm, 10 ft·lbf)**

**2TR-FE**

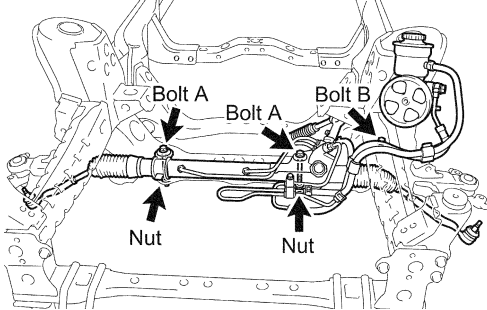

**27. REINSTALL THE POWER STEERING LINK ASSY W/ POWER STEERING VANE PUMP**

- Reinstall the power steering link assy w/ power steering vane pump with the bolts and nuts, then torque to spec.

**Torque Spec: 2TR-FE 4WD**

**Bolt A - 95 N·m (969 kgf·cm, 70 ft·lbf)**

**Bolt B - 28 N·m (286 kgf·cm, 21 ft·lbf)**

**Torque Spec: Except 2TR-FE 4WD**

**Bolt A - 92 N·m (938 kgf·cm, 68 ft·lbf)**

**Bolt B - 28 N·m (286 kgf·cm, 21 ft·lbf)**

**1GR-FE**

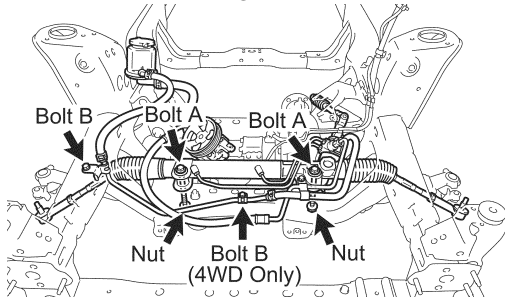

**NOTE:**

- When reinstalling the power steering link with the pump, have one person support the power steering link and the other support the pump.
- Keep the power steering pump reservoir upright to prevent the fluid from leaking out.

**28. RECONNECT THE FRONT DIFFERENTIAL BREATHER TUBE (4WD ONLY)**

- Reconnect the front differential breather tube with the bolt and 2 clamps, then torque to spec.

**Torque Spec: 12.7 N·m (130 kgf·cm, 9 ft·lbf)**

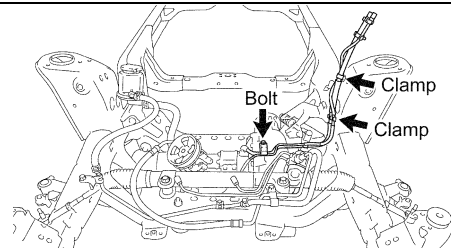

NEW Replacement Parts			
Part #	Part Name	Kit #	Qty
90080-17215	Nut	2	6

The diagram shows a front shock absorber assembly. Three arrows point to 'Nut A' locations: two on the top of the shock absorber and one on the lower mounting bracket. One arrow points to 'Nut B' on the lower mounting bracket.

### 29. REINSTALL THE FRONT SHOCK ABSORBER ASSY

- Install the 3 **NEW** nuts (A) and torque to spec.
- Reinstall the front shock absorber assy with the bolt and nut (B), then torque to spec.

**Torque Spec:**

**Nut A - 64 N·m (653 kgf·cm, 47 ft·lbf)**

**Nut B - 83 N·m (846 kgf·cm, 61 ft·lbf)**

- Repeat the procedure on the opposite side.

NEW Replacement Parts (2WD Only)			
Part #	Part Name	Kit #	Qty
90119-A0161	Bolt	NA*	4

\*Individual Part(s)

### 30. REINSTALL THE FRONT STABILIZER BAR

- Reinstall the stabilizer bar with 2 brackets and 4 **NEW** bolts, then torque to spec. (*2WD Only*)
- Reinstall the stabilizer bar with 2 brackets and 4 bolts, then torque to spec. (*4WD, Pre-Runner Only*).

**Torque Spec:**

**2WD - 21 N·m (214 kgf·cm, 15 ft·lbf)**

**4WD, Pre-Runner - 40 N·m (408 kgf·cm, 30 ft·lbf)**

**2WD Only**

The diagram shows a 2WD front stabilizer bar assembly. Two brackets are shown being attached to the ends of the stabilizer bar. Reference number R1108210010 is visible at the bottom right.

**4WD, Pre-Runner Only**

The diagram shows a 4WD, Pre-Runner front stabilizer bar assembly. Two brackets are shown being attached to the ends of the stabilizer bar. Reference number R1108210011 is visible at the bottom right.

### 31. REINSTALL THE FRONT SUSPENSION MEMBER BRACE SUB-ASSY

- Reinstall the suspension member brace sub-assy with 8 bolts (*2WD Only*) or 7 bolts (*4WD, Pre-Runner Only*), then torque to spec.

**Torque Spec: 45 N·m (459 kgf·cm, 33 ft·lbf)**

NEW Replacement Parts			
Part #	Part Name	Kit #	Qty
90311-47026	Seal, Oil (For Differential Side	3	1
90311-47027	Gear Shaft)	3	1
43425-04040	Ring, Shaft Snap (For Front Drive Inner Shaft Outer)	NA*	2

\*Individual Part(s)

### 32. REINSTALL THE FRONT DRIVE SHAFT ASSY (4WD ONLY)

- Remove the type T oil seal.
- Install the **NEW** type T oil seal.
- Install a **NEW** snap ring.
- Reinstall the front drive shaft assy.
- Repeat the procedure on the opposite side.

**NOTE:**

**Be careful not to damage the dust cover and oil seal.**

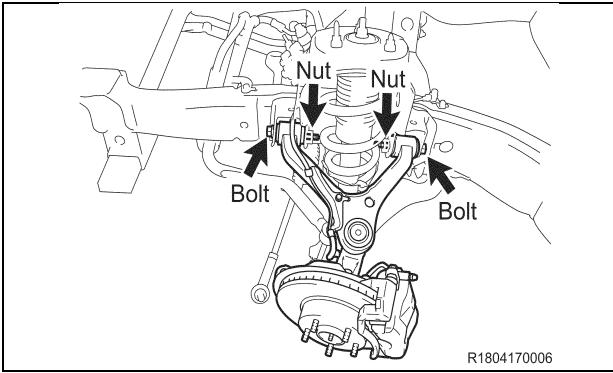

**33. REINSTALL THE FRONT SUSPENSION UPPER ARM AND STEERING KNUCKLE ASSY (2WD ONLY)**

- a) Reinstall the front suspension upper arm w/ steering knuckle with the 2 bolts, 2 nuts and 2 washers, then torque to spec.

**Torque Spec: Bolt - 82 N·m (836 kgf·cm, 60 ft·lbf)**

- b) Repeat the procedure on the opposite side.

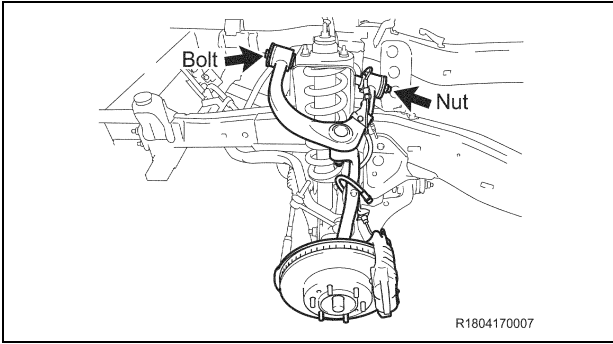

**34. REINSTALL THE FRONT SUSPENSION UPPER ARM AND STEERING KNUCKLE ASSY (4WD, PRE-RUNNER ONLY)**

- a) Reinstall the front suspension upper arm w/ steering knuckle with the bolt, nut and 2 washers, then torque to spec.

**Torque Spec: Nut - 115 N·m (1173 kgf·cm, 85 ft·lbf)**

- b) Repeat the procedure on the opposite side.

**35. REINSTALL THE FOLLOWING PARTS**

- Lower Ball Joint Attachment
  - Reinstall the lower ball joint attachment with the **NEW** nut and 2 bolts, then torque to spec.
  - Install the **NEW** cotter pin.
  - Repeat the procedure on the opposite side.
  - **Torque Spec:**  
**Nut - 140 N·m (1428 kgf·cm, 103 ft·lbf)**  
**Bolt - 160 N·m (1632 kgf·cm, 118 ft·lbf)**
- Front Stabilizer Link Assy (2WD Only)
  - Reinstall the front stabilizer link assy with 2 retainers, 2 cushions and nut, torque to spec.
  - **Torque Spec: 19 N·m (194 kgf·cm, 14 ft·lbf)**
  - Reinstall the nut, then torque to spec.
  - **Torque Spec: 69 N·m (704 kgf·cm, 51 ft·lbf)**
  - Repeat the procedure on the opposite side.
- Front Stabilizer Link Assy (4WD, Pre-Runner Only)
  - Reinstall the front stabilizer link assy with the 2 nuts, torque to spec.
  - **Torque Spec: 70 N·m (714 kgf·cm, 52 ft·lbf)**
  - Repeat the procedure on the opposite side.
- Tie Rod End
  - Reinstall the tie rod end with the nut and torque to spec.
  - **Torque Spec:**  
**2WD - 49 N·m (500 kgf·cm, 36 ft·lbf)**  
**4WD, Pre-Runner - 91 N·m (928 kgf·cm, 67 ft·lbf)**
  - Install the **NEW** cotter pin.
  - Repeat the procedure on the opposite side.
- Front Axle Shaft Nut (4WD Only)
  - Temporarily reinstall the front axle shaft nut.
  - Nut will be tightened when the vehicle is completed.
  - Repeat the procedure on the opposite side.

**NEW Replacement Parts**

**Lower Ball Joint Attachment**

Part #	Part Name	Kit #	Qty
90171-A0005	Nut, Castle (For Front Lower Ball Joint LH/RH)	2	2
95381-03230	Cotter Pin	4 or 5	2

**Tie Rod End**

Part #	Part Name	Kit #	Qty
95381-03025	Cotter Pin**	4	2
95381-03225		5	2

\*\* Only 1 part used, part number varies by vehicle type.

NEW Replacement Parts			
Part #	Part Name	Kit #	Qty
47314-04140	Tube, Front Brake, No.4**	12	1
47314-04141		13	1
47316-04140	Tube, Front Brake, No.6**	12	1
47316-04141		13	1
90412-10289	Way (For Front Brake Tube)	1	2
90119-A0169	Bolt	NA*	2

\*Individual Part(s)  
\*\* Only 1 part used, part number varies by vehicle type.

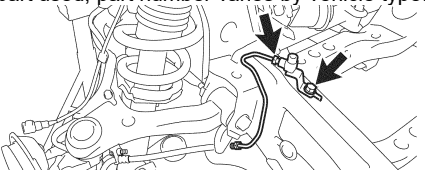

### 36. INSTALL THE **NEW** FRONT BRAKE TUBE AND **NEW** WAY (2WD ONLY)

- Temporarily install the **NEW** front brake tube and **NEW** way.
- Install the **NEW** bolt to the **NEW** way and torque to spec.  
**Torque Spec: 32 N·m (326 kgf·cm, 24 ft·lbf)**
- Repeat the procedure on the opposite side.

NEW Replacement Parts			
Part #	Part Name	Kit #	Qty
47314-04150	Tube, Front Brake, No.4**	14	1
47314-04151		15	1
47316-04150	Tube, Front Brake, No.6**	14	1
47316-04151		15	1
90412-10289	Way (For Front Brake Tube)	1	2
90119-A0169	Bolt	14 or 15	2

\*\*Only 1 part used, part number varies by vehicle type.

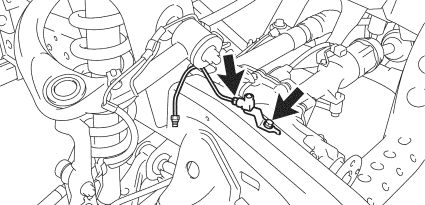

### 37. INSTALL THE **NEW** FRONT BRAKE TUBE AND **NEW** WAY (4WD, PRE-RUNNER ONLY)

- Temporarily install the **NEW** front brake tube and **NEW** way.
- Install the **NEW** bolt to the **NEW** way and torque to spec.  
**Torque Spec: 32 N·m (326 kgf·cm, 24 ft·lbf)**
  - Repeat the procedure on the opposite side.

NEW Replacement Parts			
Part #	Part Name	Kit #	Qty
90119-A0169	Bolt	NA*	4
90468-A0007	Clip	2	2

\*Individual Part(s)

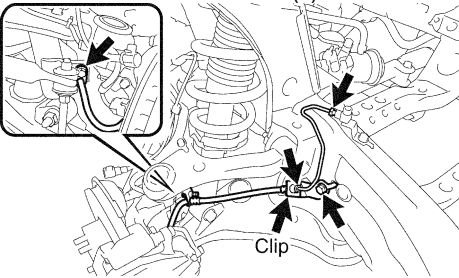

### 38. RECONNECT THE FRONT BRAKE HOSE (2WD ONLY)

- Reinstall the flexible hose bracket with the **NEW** bolt and torque to spec.  
**Torque Spec: 32 N·m (326 kgf·cm, 24 ft·lbf)**
- Reconnect the front brake hose with a **NEW** clip.
- Reconnect the front brake tube and torque to spec.  
**Torque Spec: 15.2 N·m (155 kgf·cm, 11 ft·lbf)**
- Reinstall the **NEW** bolt and torque to spec.  
**Torque Spec: 32 N·m (326 kgf·cm, 24 ft·lbf)**
- Repeat the procedure on the opposite side.

NEW Replacement Parts			
Part #	Part Name	Kit #	Qty
90119-A0169	Bolt	14 or 15	2
90468-A0007	Clip	2	2

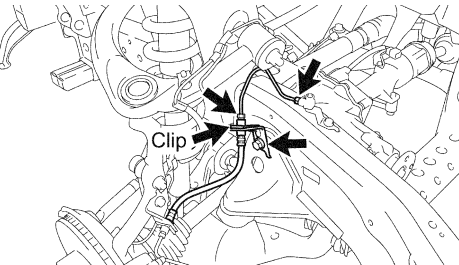

### 39. RECONNECT THE FRONT BRAKE HOSE (4WD, PRE-RUNNER ONLY)

- Reinstall the flexible hose bracket with the **NEW** bolt and torque to spec.  
**Torque Spec: 32 N·m (326 kgf·cm, 24 ft·lbf)**
- Reconnect the front brake hose with a **NEW** clip.
- Reconnect the front brake tube and torque to spec.  
**Torque Spec: 15.2 N·m (155 kgf·cm, 11 ft·lbf)**
- Repeat the procedure on the opposite side.

NEW Replacement Parts			
Part #	Part Name	Kit #	Qty
90105-A0064	Bolt	NA*	1

\*Individual Part(s)

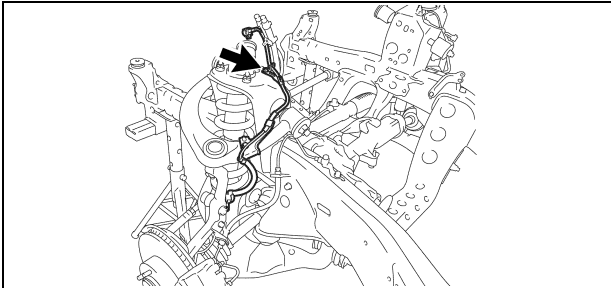
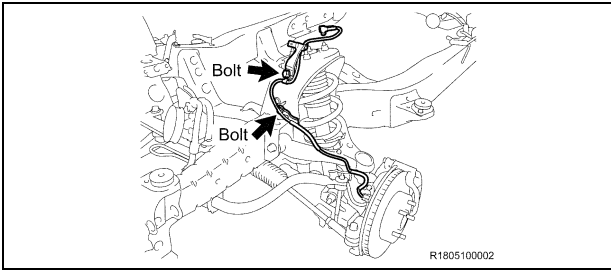

#### 40. RECONNECT THE FRONT SKID CONTROL SENSOR WIRE HARNESS (2WD ONLY)

##### 2011MY RH Side:

- Remove the clamp from the front skid control sensor wire harness.
- Install the **NEW** bolt (A) and torque to spec.

**Torque Spec: 12.5 N·m (127 kgf·cm, 9 ft·lbf)**

- Reconnect the front skid control sensor wire harness with bolt and torque to spec.

**Torque Spec: 12.5 N·m (127 kgf·cm, 9 ft·lbf)**

##### Except 2011MY RH Side:

- Reconnect the front skid control sensor wire harness with the 2 bolts.

**Torque Spec: 12.5 N·m (127 kgf·cm, 9 ft·lbf)**

- Repeat the procedure on the opposite side.

#### 41. RECONNECT THE FRONT SKID CONTROL SENSOR WIRE HARNESS (4WD, PRE-RUNNER ONLY)

- Reconnect the front skid control sensor wire harness with bolt and torque to spec.

**Torque Spec: 12.5 N·m (127 kgf·cm, 9 ft·lbf)**

- Repeat the procedure on the opposite side.

#### 42. REINSTALL THE WHEELS

#### 43. REINSTALL THE FRONT PROPELLER SHAFT ASSY (4WD ONLY)

- Referencing the matchmarks, reinstall the propeller shaft assy to the front differential.
- Reinstall the 4 bolts, 4 washer and 4 nuts, them torque to spec.

**Torque Spec: 88.2 N·m (899 kgf·cm, 65 ft·lbf)**

#### 44. REINSTALL THE ENGINE AND TRANSMISSION ASSY

- Reinstall engine and transmission assy.

##### NOTE:

- Hang up the front exhaust pipe with string to avoid applying pressure at the joint part. (2TR-FE only)
- Use 2 engine hoists/cranes to lift engine & trans assy.
- **DO NOT** use 1 engine hoist/crane to lift the engine & trans assy, the unbalanced weight may lead to an accident or injury.
- **ONLY** use engine hoists/cranes that can properly support the weight of the engine & trans.
- Carefully adjust the 2 engine hoists/cranes used so that the engine & trans assy is balanced.

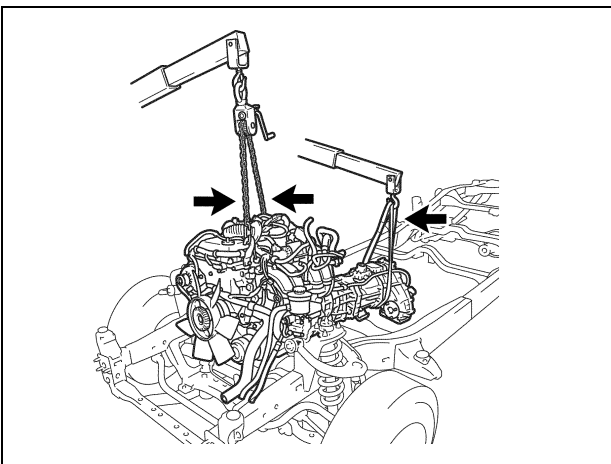

NEW Replacement Parts			
Part #	Part Name	Kit #	Qty
90910-03001	Bolt	1	4
94151-21001	Nut	1	4

**LH Side**

**RH Side**

- b) Attach the engine mounts with the 4 **NEW** bolts and 4 **NEW** nuts, then torque to spec.

**2011MY:**  
**Torque Spec: 38 N·m (387 kgf·cm, 28 ft·lbf)**

**2012-2015MY:**  
**Torque Spec: 40 N·m (408 kgf·cm, 30 ft·lbf)**

NEW Replacement Parts			
Part #	Part Name	Kit #	Qty
91671-80814	Bolt	1	4

- c) Attach the transmission mount with 4 **NEW** bolts and torque to spec.

**2011MY:**  
**Torque Spec: 18.5 N·m (189 kgf·cm, 14 ft·lbf)**

**2012-2015MY:**  
**Torque Spec: 30 N·m (306 kgf·cm, 22 ft·lbf)**

- d) Remove the bolt(s) and the engine hangers.  
 e) Reinstall the items/parts that were removed during the engine and transmission assy removal.  
 f) Reinstall the bolt and reconnect the ground wire. (*LH Side*)

**Torque Spec: 12.5 N·m (127 kgf·cm, 9 ft·lbf)**

- g) Reconnect the connector and clamp. (*4WD Only*)  
 h) Reconnect the clamp. (*2TR-FE Only*)

**LH Side**

**RH Side (4WD Only)**

**RH Side (2TR-FE Only)**

R1804230001



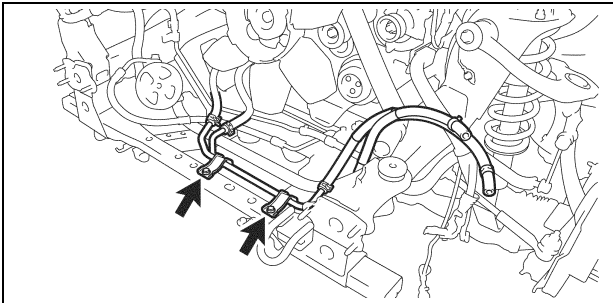

#### 45. RECONNECT THE OIL COOLER TUBE (AUTO TRANS ONLY)

- a) Reconnect the oil cooler tube with the 2 bolts and torque to spec.

**Torque Spec: 28 N·m (286 kgf·cm, 21 ft·lbf)**

#### 46. REINSTALL THE INTAKE AIR SURGE TANK (1GR-FE ONLY)

- a) Install a **NEW** gasket onto the intake air surge tank.
- b) Using a 8mm hexagon socket, reinstall the intake air surge tank with the 4 bolts and torque to spec.

**Torque Spec: 28 N·m (286 kgf·cm, 21 ft·lbf)**

- c) Reinstall the 2 intake air surge tank nuts and torque to spec.

**Torque Spec: 28 N·m (286 kgf·cm, 21 ft·lbf)**

- d) Reinstall the 2 surge tank stays with the 4 bolts, then torque to spec.

**Torque Spec: 21 N·m (214 kgf·cm, 15 ft·lbf)**

- e) Reinstall oil baffle plate with the bolt and torque to spec.

**Torque Spec: 9.0 N·m (92 kgf·cm, 80 in·lbf)**

- f) Reinstall the throttle body bracket with the 2 bolts, then torque to spec.

**Torque Spec: 21 N·m (214 kgf·cm, 15 ft·lbf)**

- g) Reconnect the 3 wire harness clamps and hose clamp.
- h) Reconnect the throttle body w/ motor connector.
- i) Reconnect the 2 VSV connectors.
- j) Reconnect the ventilation hose.
- k) Reconnect the fuel vapor feed hose.
- l) Reconnect the 2 water by-pass hoses.

#### NEW Replacement Parts

Part #	Part Name	Kit #	Qty
17176-0P030	Gasket, Air Surge Tank to Intake Manifold	6	1

#### 47. REINSTALL THE INTAKE AIR CONNECTOR (2TR-FE ONLY)

- a) Reinstall the intake air connector with the 3 bolts, then torque to spec.

**Torque Spec: 8.0 N·m (82 kgf·cm, 71 in·lbf)**

- b) Tighten the hose clamp bolts.
- c) Reconnect the vacuum hose.
- d) Reconnect the No.2 ventilation hose.
- e) Reconnect the vacuum hose.
- f) Reconnect the wire harness clamp.
- g) Reconnect the pressure sensor connector.

#### 48. REINSTALL THE POWER STEERING VANE PUMP

- a) Reinstall the bolt and reconnect the ground wire and torque to spec. (1GR-FE Only)

**Torque Spec: 8.0 N·m (82 kgf·cm, 71 in·lbf)**

- b) Reinstall the power steering vane pump with the 2 bolts, then torque to spec.

**Torque Spec: 21 N·m (214 kgf·cm, 15 ft·lbf)**

- c) Reconnect the connector.
- d) Reconnect the clamp. (1GR-FE Only)

#### 49. REINSTALL THE V-BELT

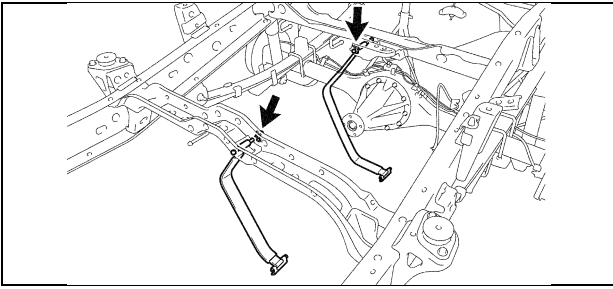

## 50. REINSTALL THE FUEL TANK STRAPS

- a) Reinstall the fuel tank straps with the 2 pins and 2 clips.

### NEW Replacement Parts

Part #	Part Name	Kit #	Qty
90119-A0249	Bolt	2	2

## 51. REINSTALL THE FUEL TANK

- a) Reinstall the fuel tank with the 2 **NEW** bolts and torque to spec.

**Torque Spec: 62 N·m (632 kgf·cm, 46 ft·lbf)**

- b) Reconnect the connector.

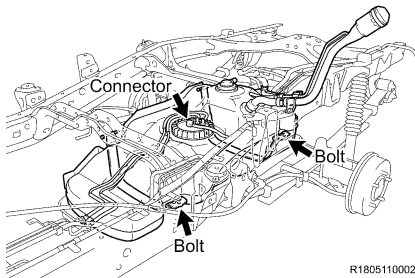

## 52. REINSTALL THE NO.2 FUEL TANK PROTECTOR (IF EQUIPPED)

### NEW Replacement Parts

Part #	Part Name	Kit #	Qty
90179-08241	Nut	NA*	4

\*Individual Part(s)

## 53. REINSTALL THE NO.1 FUEL TANK PROTECTOR ASSY (IF EQUIPPED)

- a) Reinstall the No.1 fuel tank protector assy with the 4 **NEW** nuts and torque to spec.

**Torque Spec: 20 N·m (204 kgf·cm, 15 ft·lbf)**

## 54. REINSTALL THE CHARCOAL CANISTER ASSY

- a) Reinstall the charcoal canister assy with the bolt and 3 nuts, then torque to spec.

**Torque Spec: 20 N·m (204 kgf·cm, 15 ft·lbf)**

- b) Reconnect the fuel tank vent hose.
- c) Reconnect the fuel hose.
- d) Reconnect the main tube support and reconnect the filter hose.
- e) Reconnect the connector.
- f) w/ Rear Differential Lock:  
Install the **NEW** bolt and connect the skid control sensor wire bracket and torque to spec.
- w/o Rear Differential Lock:  
Install the bolt and reconnect the skid control sensor wire bracket and torque to spec.

**Torque Spec: 12.5 N·m (127 kgf·cm, 9 ft·lbf)**

- g) Install the **NEW** clamp.

### NEW Replacement Parts

Part #	Part Name	Kit #	Qty
77285-35760	Clamp, Fuel Tube, No.1	1	1
90105-A0066	Bolt	NA*	1

\*Individual Part(s)

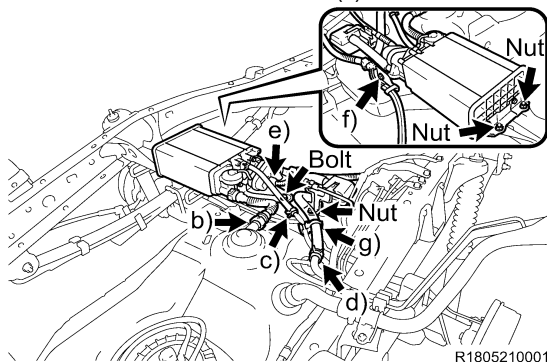

### NEW Replacement Parts

Part #	Part Name	Kit #	Qty
17451-0D020	Gasket, Exhaust Pipe	6	1

## 55. REINSTALL THE EXHAUST SYSTEM (1GR-FE ONLY)

- a) Reconnect the 2 exhaust pipe supports to the frame.
- b) Install the **NEW** exhaust pipe gasket.

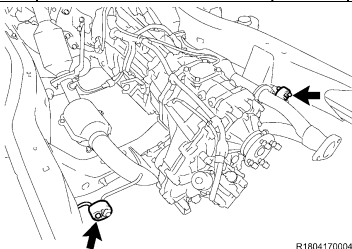

**NEW Replacement Parts**

Part #	Part Name	Kit #	Qty
90080-10291	Bolt	6	2

R1107190014

- c) Reconnect the 4 exhaust pipe supports to the frame and reinstall the center exhaust pipe assy.
- d) Install the 2 **NEW** bolts and 2 springs, then torque to spec.

**Torque Spec: 43 N·m (438 kgf·cm, 32 ft·lbf)**

**56. REINSTALL THE EXHAUST SYSTEM (2TR-FE ONLY)**

**NEW Replacement Parts**

Part #	Part Name	Kit #	Qty
90080-43033	Gasket	7	1
90080-10064	Bolt	7	2
90177-A0004	Nut	7	2

- a) Reconnect the exhaust pipe support to the frame.
- b) Reconnect the 2 oxygen sensor wire harness clamps.
- c) Install the **NEW** exhaust pipe gasket.
- d) Reconnect the 4 exhaust pipe supports to the frame and reinstall the center exhaust pipe assy.
- e) Install the 2 **NEW** bolts and 2 **NEW** nuts then torque to spec.

**Torque Spec: 48 N·m (489 kgf·cm, 35 ft·lbf)**

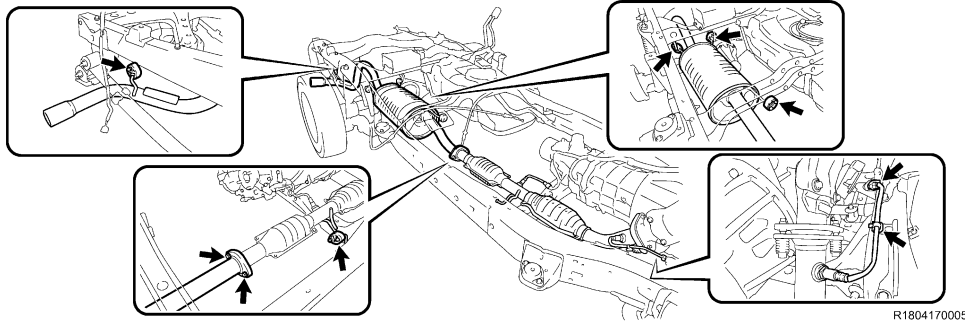

**NEW Replacement Parts**

Part #	Part Name	Kit #	Qty
90080-11180	Bolt	6	2

**57. REINSTALL THE EXHAUST PIPE STOPPER BRACKET (IF EQUIPPED)**

- a) Reinstall the exhaust pipe stopper bracket with the 2 **NEW** bolts and torque to spec.

**Torque Spec: 19 N·m (194 kgf·cm, 14 ft·lbf)**

**NEW Replacement Parts**

Part #	Part Name	Kit #	Qty
90119-A0151	Bolt	NA*	2

\*Individual Part(s)

**58. REINSTALL THE PROPELLER SHAFT HEAT INSULATOR (IF EQUIPPED)**

- a) Reinstall the propeller shaft heat insulator with the 2 **NEW** bolts and torque to spec.

**Torque Spec: 15.7 N·m (160 kgf·cm, 12 ft·lbf)**

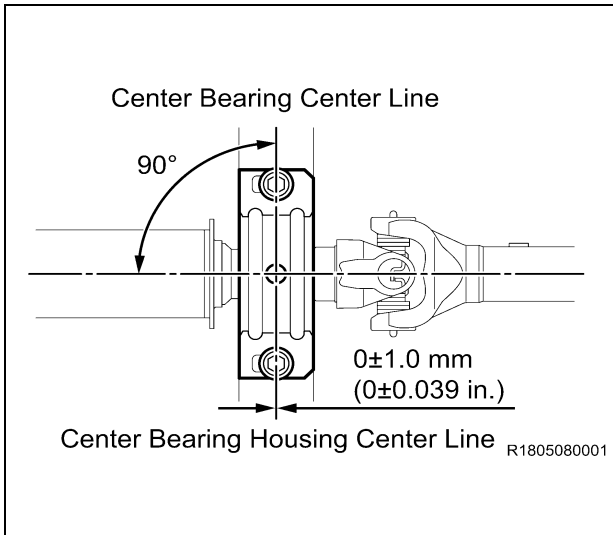

### 59. REINSTALL THE REAR PROPELLER SHAFT ASSY

- a) Remove the SST. *(2WD Only)*
- b) Referencing the matchmarks, reinstall the rear propeller shaft assy to the transmission / transfer case.
- c) Reinstall the 4 washers and 4 nuts, then torque to spec. *(4WD Only)*

**Torque Spec: 88.2 N·m (899 kgf·cm, 65 ft·lbf)**

- d) Reinstall the center support bearing to the frame as shown in the illustration with 2 washers and 2 bolts, then torque to spec. *(3-Joint Type Only)*

**Torque Spec: 36.2 N·m (369 kgf·cm, 27 ft·lbf)**

- e) Referencing the matchmarks, reinstall the rear propeller shaft assy to the rear differential with 4 bolts, 4 washers and 4 nuts, then torque to spec.

**Torque Spec: 88.2 N·m (899 kgf·cm, 65 ft·lbf)**

### 60. RECONNECT THE FRONT PROPELLER SHAFT ASSY (4WD ONLY)

- a) Referencing the matchmarks, reconnect the front propeller shaft assy to the transfer case and the front differential with 4 bolts, 4 washers and 4 nuts, then torque to spec.

**Torque Spec: 88.2 N·m (899 kgf·cm, 65 ft·lbf)**

### 61. REMOVE THE FRAME FROM THE LIFT

- a) Remove the ratcheting tie down strap from the frame.
- b) Lower the frame to the ground.

## I. REINSTALL THE CAB BODY ASSY



Before lowering the cab assembly ensure that you install the **NEW** brakelines onto the bulk head.

NEW Replacement Parts			
Part #	Part Name	Kit #	Qty
47313-04200	Tube, Front Brake, No.3**	10	1
47313-04231		11	1
47313-04210		NA*	1
47313-04241	Tube, Front Brake, No.5**	NA*	1
47315-04170		10	1
47315-04171		11	1
47315-04180		NA*	1
47315-04191	Tube, Rear Brake, No.3**	NA*	1
47323-04170		10	1
47323-04171		11	1
47323-04180		NA*	1
4732304191	Tube, Rear Brake, No.4**	NA*	1
47324-04130		10	1
47324-04131		11	1
47324-04140		NA*	1
47324-04151		NA*	1

\*Individual Part(s)  
\*\*Only 1 part used, part number varies by vehicle type.

### 1. INSTALL THE NEW ENGINE COMPARTMENT BRAKE TUBES

- Install the **NEW** No.3 and **NEW** No.5 front brake tubes.
- Install the **NEW** No.3 and **NEW** No.4 rear brake tubes.
- Torque all brake tubes to spec.

#### Torque Spec:

Flare Nut (M10) - 15.2 N·m (155 kgf·cm, 11 ft·lbf)

Flare Nut (M12) - 19.5 N·m (199 kgf·cm, 14 ft·lbf)

### 2. REINSTALL THE CAB BODY ASSY

- Raise the cab assy high enough so that the top of the engine clears the lowest point of the cab.
- Push the frame under the cab assy and line the tires up with the alignment marks.
- Lower the cab assy slowly, making sure it does not interfere with anything.
- Adjust the vehicle's frame as needed to align the cab mounts with the cab assy bolts.
- Once the cab assy is set on the mounts, secure it to the frame with 6 bolts, 6 nuts, 6 washers and torque to spec.

#### Torque Spec:

No.1 - 37.5 N·m (382 kgf·cm, 28 ft·lbf)

No.2, No.3 - 45 N·m (459 kgf·cm, 33 ft·lbf)

- Reinstall the 4 hole plugs.

#### NOTE:

- DO NOT work directly underneath the vehicle when pushing the frame under the cab assy.
- Slowly lower the cab assy making sure the wire harness, steering shaft & hoses don't interfere.
- With 2 to 3 people checking for interference, slowly lower the cab body assembly to the frame.

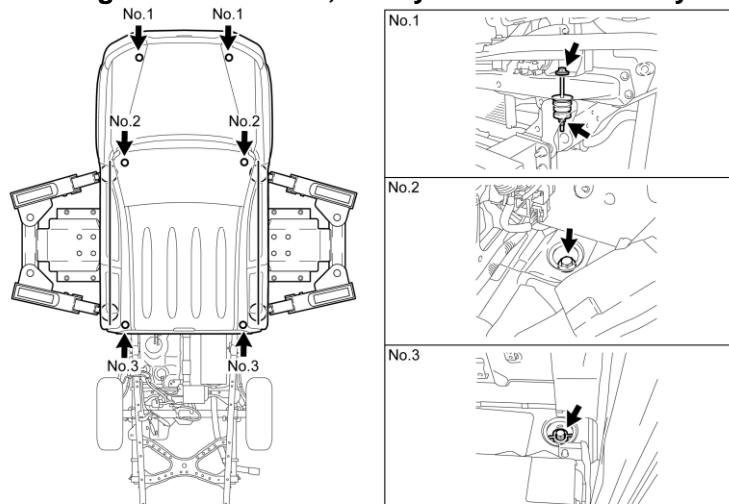

R1107190012 01

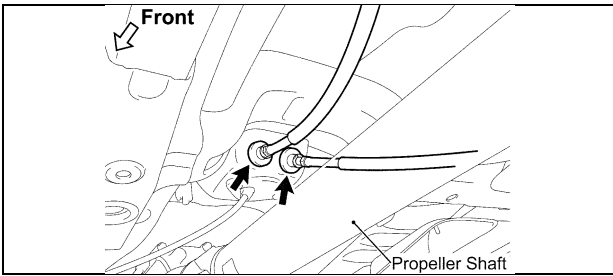

### 3. RECONNECT THE PARKING BRAKE CABLE

NEW Replacement Parts			
Part #	Part Name	Kit #	Qty
90412-10276	Way, 2 (For Rear Brake Tube)	2	1
90119-A0169	Bolt	14 or 15 or NA*	1

### 4. CONNECT THE REAR BRAKE TUBES

- Temporarily install the **NEW** 2 way with the **NEW** bolt.
- Temporarily install the 4 rear brake tubes.
- Torque the bolt to spec.

**Torque Spec: 32 N·m (326 kgf·cm, 24 ft·lbf)**

- Torque the 4 rear brake tubes to spec.

**Torque Spec: 15.2 N·m (155 kgf·cm, 11 ft·lbf)**

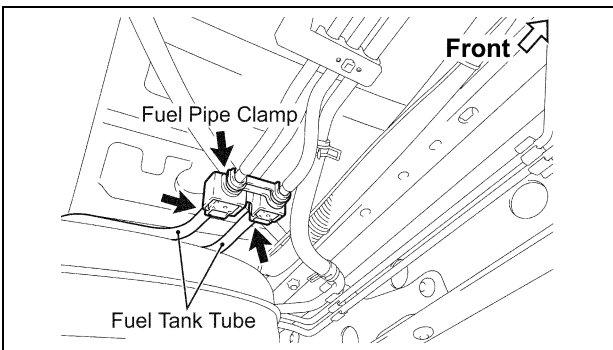
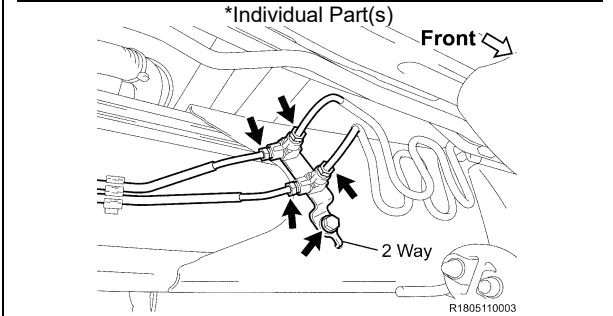

### 5. RECONNECT THE FUEL TANK TUBES

- Reconnect the 2 fuel tank tubes.
- Reinstall the fuel pipe clamp.

**NOTE:**

- Align the connector with the pipe, and push into the connector until the connector makes a "click" sound. If the connection is tight, apply a little amount of fresh engine oil on the tip of the pipe.
- Ensure the pipe and the connector are securely connected by pulling them.

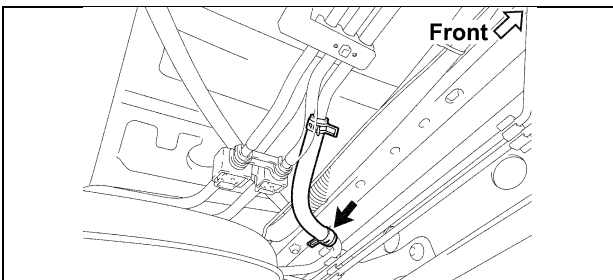

### 6. RECONNECT THE NO.2 FUEL HOSE

- Reconnect the No.2 fuel hose with the clip.

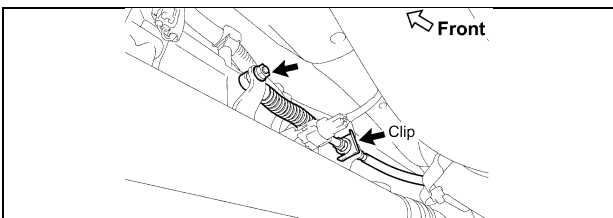

### 7. RECONNECT THE SHIFT CABLE (AUTO TRANS ONLY)

**Cable Type (Shown):**

- Reconnect the shift cable with the nut and torque to spec.

**Torque Spec: 14 N·m (143 kgf·cm, 10 ft·lbf)**

- Install the clip.

**Rod Type:**

- Reconnect the shift cable with the **NEW** pin and **NEW** clip.

NEW Replacement Parts (Rod Type)			
Part #	Part Name	Kit #	Qty
90468-14033	Clip	NA*	1
90240-08054	Pin, W/ Hole (For Transmission Control Rod)	NA*	1

\*Individual Part(s)

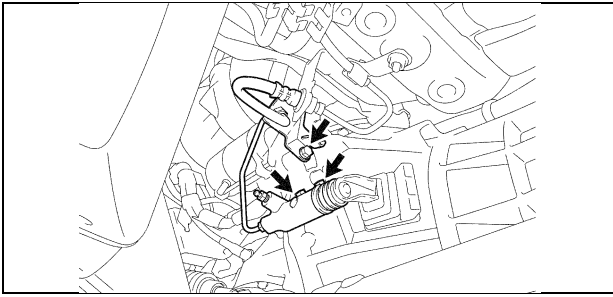

**8. RECONNECT THE CLUTCH RELEASE CYLINDER ASSY (2TR-FE MANUAL TRANS ONLY)**

- a) Reconnect the clutch release cylinder with the 2 bolts and torque to spec.

**Torque Spec: 11.8 N·m (120 kgf·cm, 9 ft·lbf)**

- b) Reconnect the clutch hose with the bolt and torque to spec.

**Torque Spec: 37 N·m (377 kgf·cm, 27 ft·lbf)**

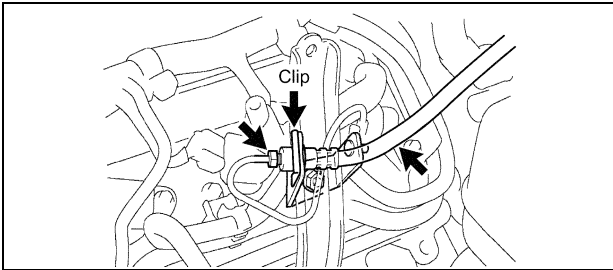

**9. RECONNECT THE NO.1 CLUTCH HOSE (1GR-FE MANUAL TRANS ONLY)**

- a) Reconnect the No.1 clutch hose with the clip.
- b) Reconnect the clutch release cylinder tube to the clutch hose.

**Torque Spec: 15.2 N·m (155 kgf·cm, 11 ft·lbf)**

**NEW Replacement Parts**

Part #	Part Name	Kit #	Qty
90080-11555	Bolt	2	2

**10. RECONNECT THE STEERING SLIDING YOKE**

- a) Make sure the front wheels are in a straight-ahead position and the steering wheel is centered.
- b) Referencing the match marks, reconnect the steering sliding yoke to the No.2 intermediate shaft with the **NEW** bolt (B).
- c) Remove bolt (A) and install the **NEW** bolt (A).
- d) Torque all bolts to spec.

**Torque Spec: 35 N·m (357 kgf·cm, 26 ft·lbf)**

- e) Disconnect the seat belt that is holding the steering wheel.

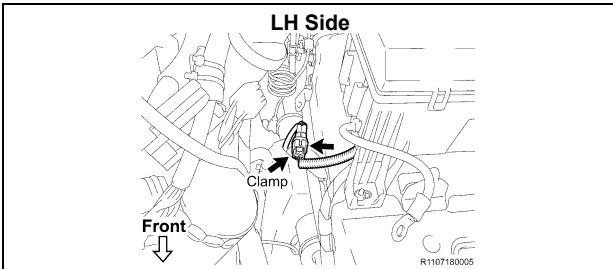

**11. RECONNECT THE FRONT SKID CONTROL SENSOR WIRE HARNESS**

- a) Reconnect the harness clamp and front skid control sensor connector.
- b) Repeat the procedure on the opposite side.

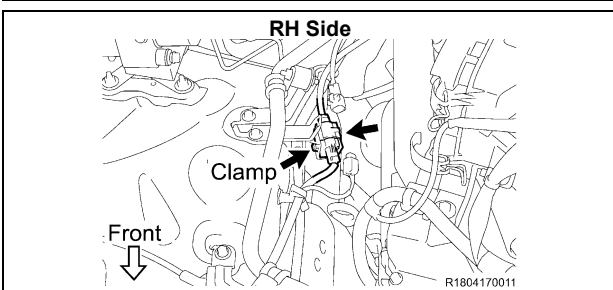
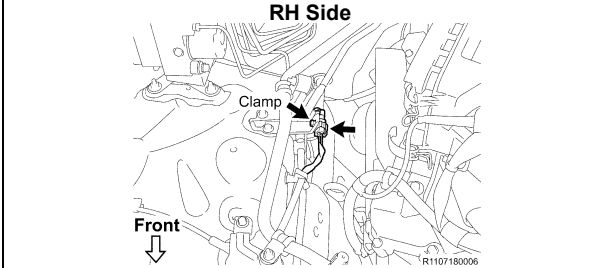

**12. RECONNECT THE NO.2 FRAME WIRE HARNESS (IF EQUIPPED)**

- a) Reconnect the harness clamp and connector.

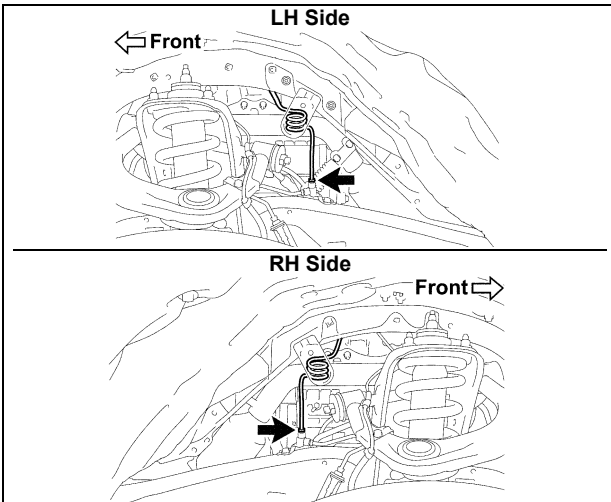

### 13. CONNECT THE FRONT BRAKE TUBES

- a) Connect the front brake tube and torque to spec.

**Torque Spec: 15.2 N·m (155 kgf·cm, 11 ft·lbf)**

- b) Repeat the procedure on the opposite side.

**NEW Replacement Parts**

Part #	Part Name	Kit #	Qty
90210-A0002	O Ring	2	1
90210-A0004	O Ring	2	1

R1804170009

### 14. RECONNECT THE AIR CONDITIONING DISCHARGE AND SUCTION HOSES TO THE COMPRESSOR

- a) Install a **NEW** o-ring to the A/C discharge and suction hoses.
- b) Reconnect the A/C discharge and suction hoses to the compressor, then torque to spec.

**Torque Spec: 19 N·m (194 kgf·cm, 14 ft·lbf)**

### 15. RECONNECT THE SUCTION HOSE BRACKET

- a) Reconnect the suction hose bracket with the bolt and torque to spec.

**Torque Spec: 7.5 N·m (76 kgf·cm, 66 in·lbf)**

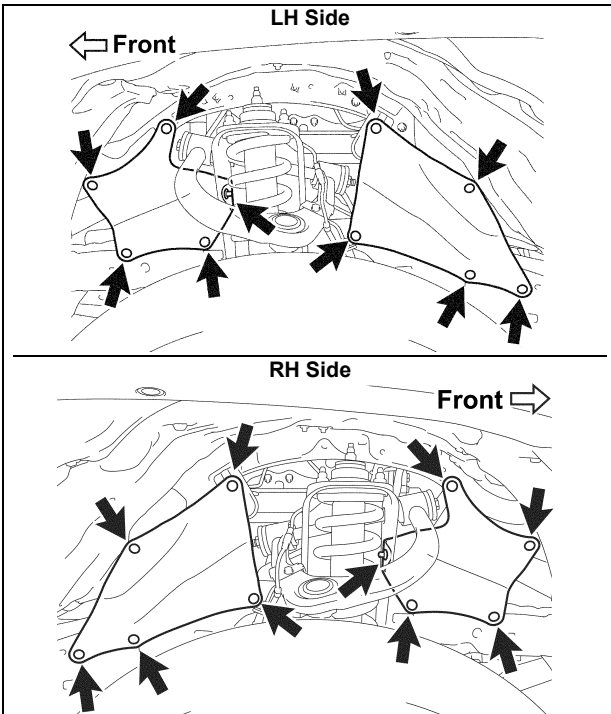

### 16. REINSTALL THE FRONT FENDER APRON SEALS

**4WD, Pre-Runner Only (Shown):**

- a) Reinstall the 4 front fender apron seals with the 20 clips.

**2WD Only:**

- b) Reinstall the 4 front fender apron seals with the 22 clips.

### 17. RECONNECT THE WATER / HEATER HOSES, ENGINE SIDE



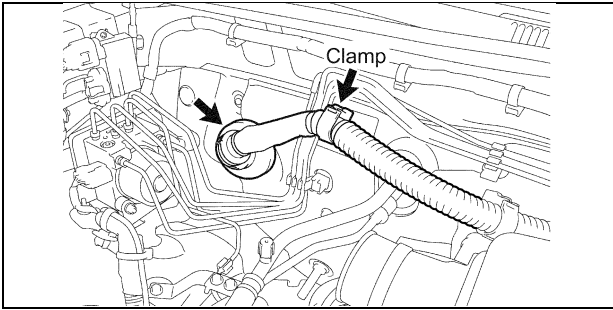

## 18. RECONNECT THE ENGINE WIRE HARNES

- a) Reinstall the engine wire harness container to the cowl panel.
- b) Reconnect the clamp.

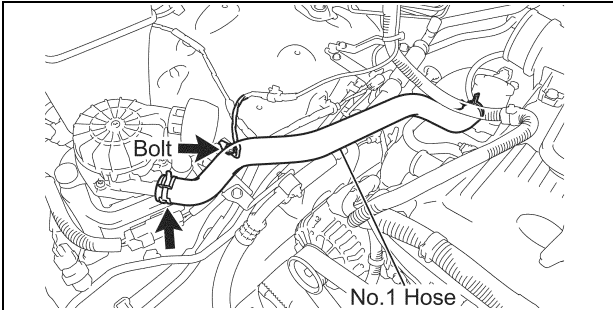

## 19. RECONNECT THE NO.1 HOSE

### 2TR-FE Only (Shown):

- a) Reconnect the ground wire with the bolt.
- Torque Spec: 8.0 N·m (82 kgf·cm, 71 in·lbf)**
- b) Reconnect the No.1 hose to the air pump assy.

### 2012-2015MY (1GR-FE Only):

- c) Reconnect the No.1 hose to the air pump assy.

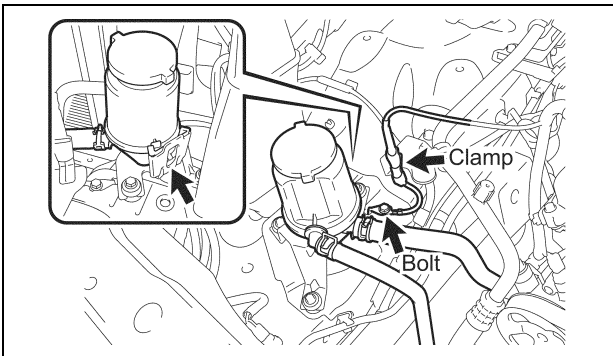

## 20. RECONNECT THE POWER STEERING PUMP OIL RESERVOIR ASSY (1GR-FE ONLY)

- a) Reconnect the power steering pump oil reservoir assy.

## 21. RECONNECT THE GROUND WIRE (1GR-FE ONLY)

- a) Reconnect the ground wire with the bolt.
- Torque Spec: 8.0 N·m (82 kgf·cm, 71 in·lbf)**
- b) Reconnect the clamp.

## 22. REINSTALL THE FAN SHROUD

## 23. REINSTALL THE RADIATOR ASSY

- a) Install the **NEW** o-ring to the drain plug.
- b) Tighten the radiator drain plug.
- c) Reinstall the radiator with 4 bolts and torque to spec.

**Torque Spec: 18 N·m (184 kgf·cm, 13 ft·lbf)**

- d) Reinstall the automatic transmission cooler lines (*Auto Trans Only*).

- e) Reinstall the fan shroud with the 2 bolts.

**Torque Spec: 5.0 N·m (51 kgf·cm, 44 in·lbf)**

## 24. RECONNECT THE RADIATOR HOSES

## 25. REINSTALL THE RADIATOR SUPPORT TO FRAME SEAL

## 26. RECONNECT THE VACUUM HOSE

- a) Reconnect the vacuum hose.

NEW Replacement Parts			
Part #	Part Name	Kit #	Qty
90069-08019	Packing (For Radiator Drain Cock)	2	1

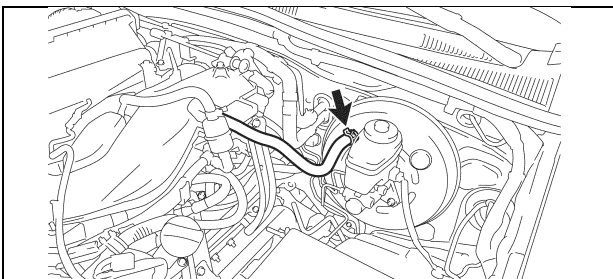

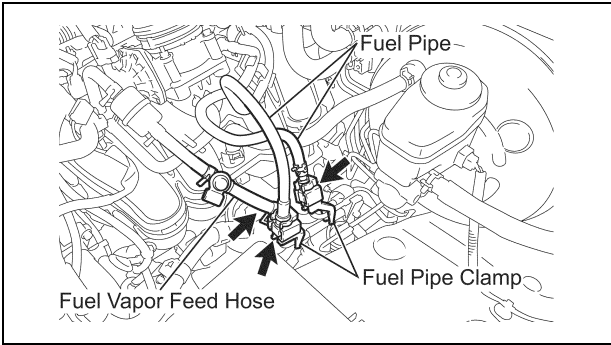

## 27. RECONNECT THE FUEL PIPES

- a) Reconnect the No.1 and No.2 fuel pipe.

### NOTE:

- Align the connector with the pipe, and push into the connector until the connector makes a "click" sound. If the connection is tight, apply a little amount of fresh engine oil on the tip of the pipe.
- Ensure the pipe and the connector are securely connected by pulling them.

- b) Reinstall the 2 fuel pipe clamps.

## 28. RECONNECT THE FUEL VAPOR FEED HOSE

## 29. RECONNECT THE FRONT DIFFERENTIAL BREATHER TUBES (4WD ONLY)

- a) Reconnect the front differential breather tubes.

**NOTE:** There may be 2 different breather tubes depending on the vehicle spec.

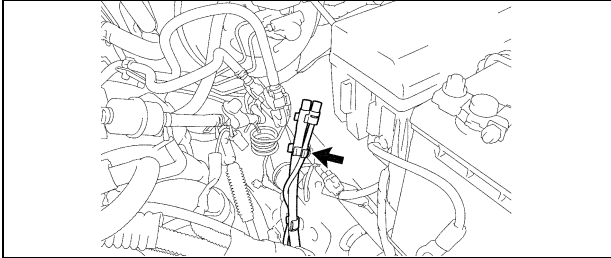

## 30. RECONNECT THE NO.2 ENGINE WIRE HARNESS

- a) Remove the upper relay block cover.
- b) Reconnect the 3 connectors.
- c) Reconnect fuse box wire harness with the nut and torque to spec.

**Torque Spec: 11 N·m (112 kgf·cm, 8 ft·lbf)**

- d) Reinstall the No.1 upper relay block cover.

- e) Reconnect the No.2 engine wire harness with the 2 clamps.

- f) Reconnect the (+) positive battery cable with the nut and torque to spec.

**Torque Spec: 7.6 N·m (77 kgf·cm, 67 in·lbf)**

- g) Reconnect the ground wire with the bolt and torque to spec.

**Torque Spec: 8.0 N·m (82 kgf·cm, 71 in·lbf)**

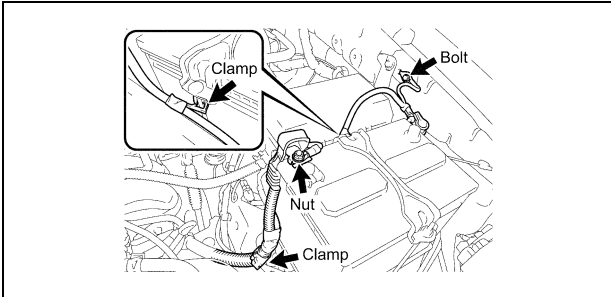
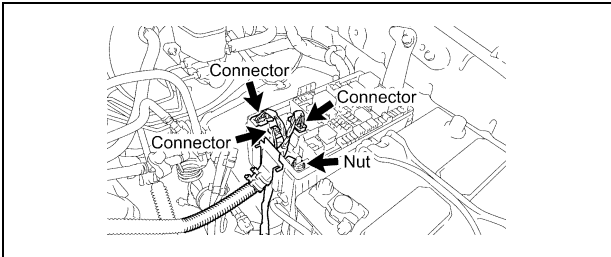

## 31. REINSTALL THE FOLLOWING PARTS

- Air Cleaner Assy (1GR-FE Only)
  - **Torque Spec: 8.0 N·m (82 kgf·cm, 71 in·lbf)**
- Air Cleaner Hose and Air Cleaner Assy (2TR-FE Only)
  - **Torque Spec: 12 N·m (122 kgf·cm, 9 ft·lbf)**
- V-Bank Cover (1GR-FE Only)
  - **Torque Spec: 7.5 N·m (76 kgf·cm, 66 in·lbf)**

## 32. REINSTALL THE FOLLOWING PARTS (ACCESS CAB ONLY)

- Rear Floor Side Service Hole Cover LH/RH
- Seat Floor Box
- Floor Board No.1/No.2
- No.1 w/ Box Speaker Assy (If Equipped)
- Rear Seat Cushion Assy
- Rear Lower Console Box

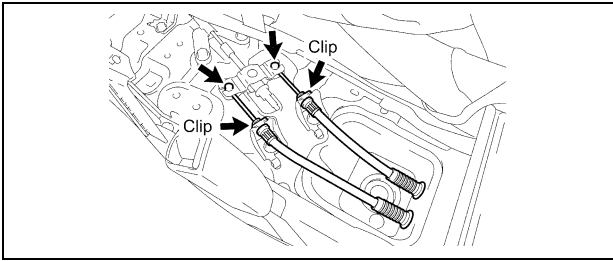

### 33. RECONNECT THE PARKING BRAKE CABLES

#### For Separate Seat Type:

- a) Reconnect the 2 parking brake cables.
- b) Reinstall the 2 clips.

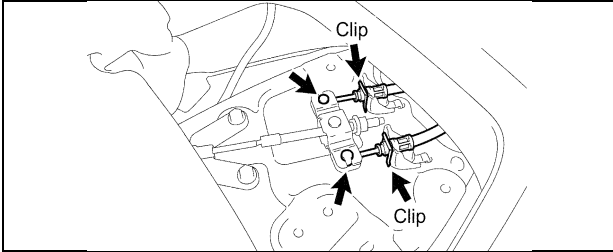

#### For Bench Seat Type:

- c) Reconnect the 2 parking brake cables.
- d) Reinstall the 2 clips.

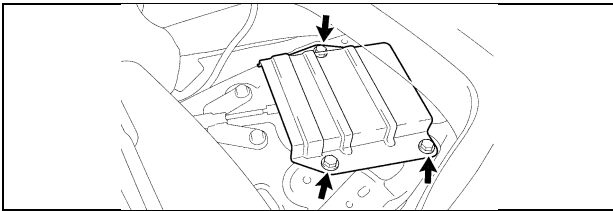

- e) Reinstall the parking brake cable joint protector with the 3 bolts and torque to spec.

**Torque Spec: 12.5 N·m (127 kgf·cm, 9 ft·lbf)**

- f) Turn back the floor carpet.

### 34. REINSTALL THE FOLLOWING PARTS

- Manual Transmission Shift Lever (*Manual Trans Only*)
- Voltage Inverter Assy (*If Equipped*)
- Front Console Box (*Manual Trans Only*)
- Rear Console Box (*for Separate Seat Type*)

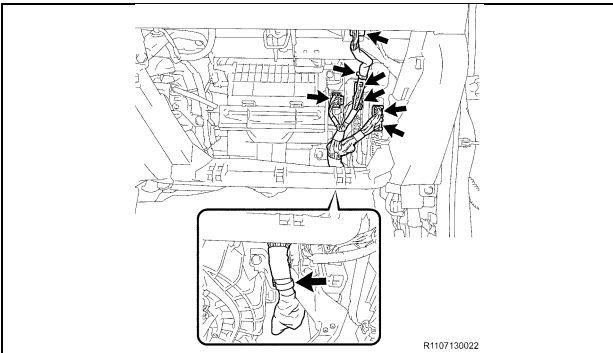

### 35. RECONNECT THE ENGINE WIRE HARNESS

- a) Reconnect each connector and clamp to the ECM and engine wire harness.

**NOTE: The number of connectors may differ depending on the model.**

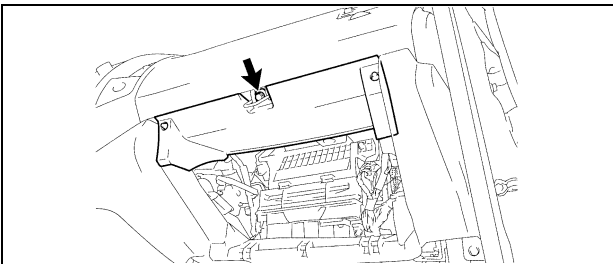

### 36. REINSTALL THE GLOVE BOX AND THE LOWER INSTRUMENT PANEL FINISH PANEL

- a) Reconnect the radio setting condenser connector (*If Equipped*).
- b) Reinstall the lower instrument panel finish panel with the bolt.
- c) Reinstall the glove box.

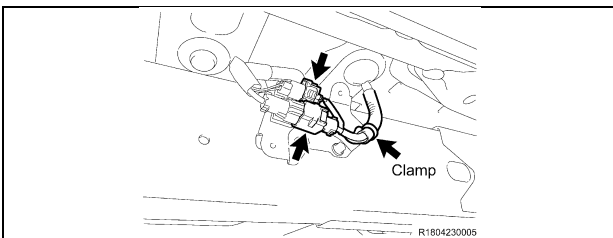

### 37. RECONNECT THE NO.2 FRAME WIRE HARNESS (IF EQUIPPED)

#### For Frame Connecting Type:

- a) Reconnect the 2 connectors and clamp.
- b) Reinstall the wiring harness protector cover with the 2 **NEW** bolts and torque to spec.

**Torque Spec: 8.0 N·m (82 kgf·cm, 71 in·lbf)**

#### NEW Replacement Parts

Part #	Part Name	Kit #	Qty
90119-A0148	Bolt	NA*	2

\*Individual Part(s)

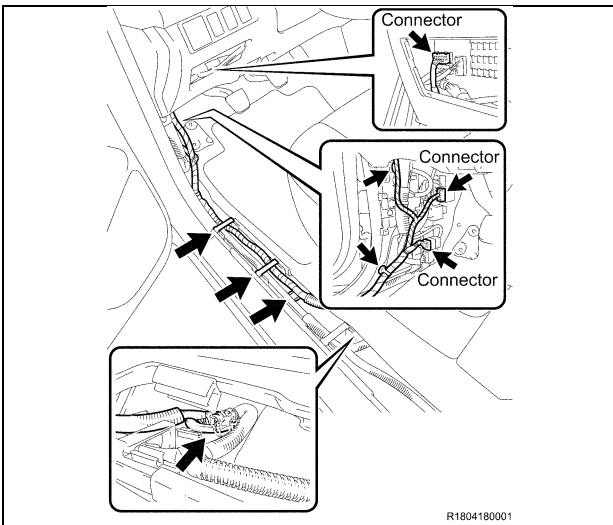
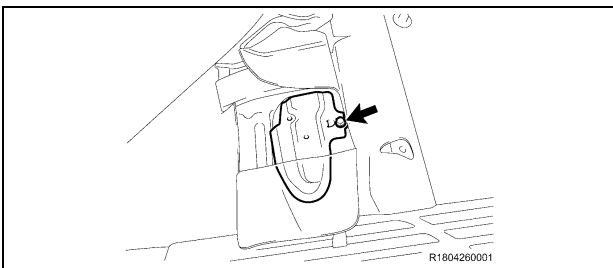
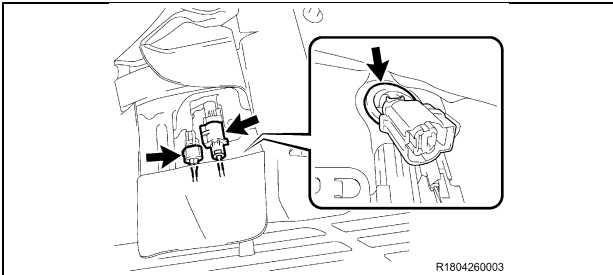
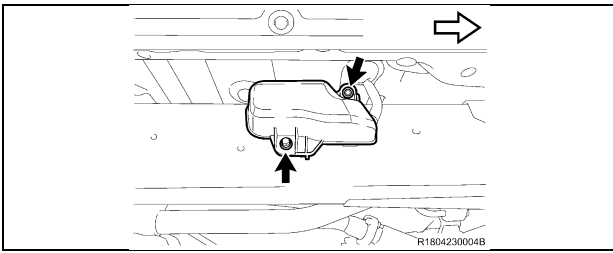

### For Floor Connecting Type:

- c) Insert the No.2 frame wire harness into the cab assy.
- d) Reinstall the No.2 frame wire harness grommet to the cab assy.
- e) Reconnect the 2 connectors.
- f) Reinstall the wiring harness protector with the bolt and torque to spec.  
**Torque Spec: 8.0 N·m (82 kgf·cm, 71 ft·lbf)**
- g) Turn back the floor carpet.
- h) Reinstall the passenger side seat with the 4 bolts and torque to spec.  
**Torque Spec: 37 N·m (377 kgf·cm, 27 ft·lbf)**

### 38. RECONNECT THE FRAME WIRE HARNESS

- a) Insert the frame wire harness into the cab assy.
- b) Reinstall the frame wire harness grommet to the cab assy.
- c) Reconnect the connector(s).
- d) Reconnect the 5 clamps.

**NOTE: The number of connectors may differ depending on the model.**

### 39. REINSTALL THE FOLLOWING INTERIOR COMPONENTS

- Instrument Panel Box
- Cowl Side Trim Board LH/RH
- Front Floor Footrest
- Front Door Scuff Plate LH/RH

**NEW Replacement Parts**

**Front No.2 Bumper Extension Sub-Assy LH/RH**

Part #	Part Name	Kit #	Qty
90178-A0044	Nut	2	6

**40. REINSTALL THE FOLLOWING BODY COMPONENTS**

- Front No.2 Bumper Extension Sub-assy LH/RH
  - Reinstall the front No.2 bumper extension with 6 **NEW** nuts and torque to spec.
  - **Torque Spec: 58 N·m (591 kgf·cm, 43 ft·lbf)**
- Front Bumper Reinforcement
  - Reinstall the front bumper reinforcement with 6 nuts and torque to spec.
  - **Torque Spec: 58 N·m (591 kgf·cm, 43 ft·lbf)**
- Front Bumper Assy (2011MY):
  - Reinstall the front bumper assy with the 6 screws and 9 clips.
- Front Bumper Assy (2012-2015MY):
  - Reinstall the front bumper assy with the 2 bolts, 6 screws and 5 clips.
- Front Fender Mudguard LH/RH
- Front Bumper Filler LH/RH (Except 2011MY)
- Radiator Grille

**J. REINSTALL THE BED ASSY**

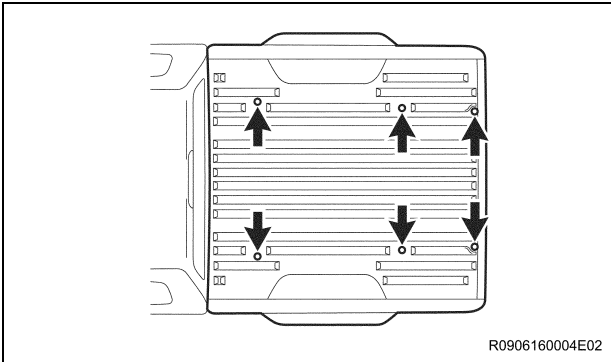

**1. REINSTALL THE BED ASSY**

- a) Using a Torx® T55H Socket, reinstall the bed assy Torx® bolts and torque to spec.

**Torque Spec: 60 N·m (612 kgf·cm, 44 ft·lbf)**

**NOTE:**

- Use 4 or more people to lift the bed assy.
- Evenly support the bed assy when reinstalling it.
- Be careful not to damage or hit the fuel inlet pipe when reinstalling the bed assy.
- Protect the front side of the bed assy to not damage the cab assy.

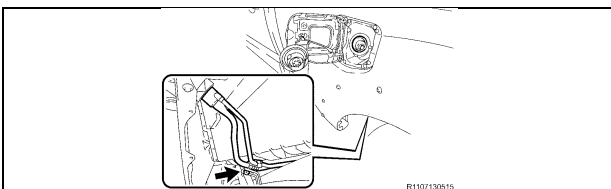

**2. REINSTALL THE FUEL INLET PIPE SUB-ASSY**

- a) Reinstall the fuel inlet pipe sub-assy with the bolt and torque to spec.

**Torque Spec: 20 N·m (204 kgf·cm, 15 ft·lbf)**

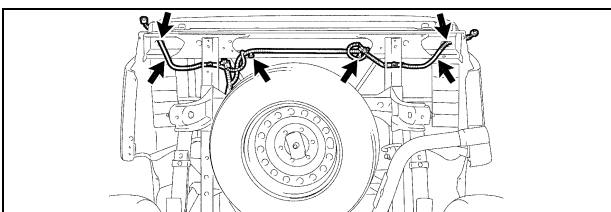

**3. RECONNECT THE FRAME WIRE HARNESS**

- a) Reconnect the clamps to the bed assy.

**NOTE:**

- The number of connectors will differ depending on the vehicle spec.
- Use new clamps if the original ones are damaged.

**NEW Replacement Parts**

**Left Rear Wheel Well Liner**

Part #	Part Name	Kit #	Qty
90189-A0002	Clip**	8	8
90189-A0002		9	6

\*\*Only 1 part used, part number varies by vehicle type.

**Quarter Panel Wheel Opening Moulding**

Part #	Part Name	Kit #	Qty
90189-A0002	Clip	8	2
75395-35070	Clip	8	3
75396-35020	Clip	8	7

**Body Rocker Panel Moulding Assy LH**

Part #	Part Name	Kit #	Qty
75395-35070	Clip	9	2
75396-35020	Clip	9	1
90189-A0002	Clip	9	1

**Outside LH Back Door Moulding Sub-Assy**

Part #	Part Name	Kit #	Qty
75395-35070	Clip	9	2
75396-35020	Clip	9	1
90189-A0002	Clip	9	1

**Rocker Panel Moulding LH/RH**

Part #	Part Name	Kit #	Qty
75395-04010	Clip	9	4
75396-04010	Clip	9	14

**Rear Bumper Assy**

Part #	Part Name	Kit #	Qty
90119-A0192	Bolt	2	6

**4. REINSTALL THE FOLLOWING PARTS**

- Power Outlet Socket Assy (*If Equipped*)
- Left Rear Wheel Well Liner
- Quarter Panel Wheel Opening Moulding LH (*If Equipped*)
- Body Rocker Panel Moulding Assy LH (*If Equipped*)
- Outside LH Back Door Moulding Sub-Assy (*If Equipped*)
- Side Step Assy LH/RH (*If Equipped*)
- Rocker Panel Moulding LH/RH (*If Equipped*)
- Rear Mudguard LH/RH (*If Equipped*)
- Rear Bumper Assy
  - Reinstall the rear bumper assy with the 10 **NEW** bolts and torque to spec. (*Trailer Hitch Equipped Vehicles Only*)
  - Reinstall the rear bumper assy with the 6 **NEW** bolts and torque to spec.
  - **Torque Spec: 90 N·m (918 kgf-cm, 66 ft-lbf)**
- Rear Tail/Combination Light LH/RH

## K. FINAL ASSEMBLY

### 1. RECONNECT THE NEGATIVE (-) BATTERY TERMINAL

**NEW Replacement Parts**

**Front Differential**

art #	Part Name	Kit #	Qty
12157-10010	Gasket, Front Differential Filler Plug	3	1
90430-24003	Gasket, Front Differential Drain Plug	3	1

### 2. REFILL THE FOLLOWING FLUIDS

- Brake Fluid
    - Remove the brake tubes from the master cylinder.
    - Refill with Toyota Dot 3 Brake Fluid.
    - Bleed the master cylinder.
    - Reinstall the brake tubes to the master cylinder and torque to spec.
    - **Torque: 19.5 N·m (199 kgf·cm, 14 ft·lbf)**
    - Refill with Toyota Dot 3 Brake Fluid.
    - Bleed the brake system at each wheel and torque the bleeder screws to spec.
    - **Torque Spec: 10.8 N·m (110 kgf·cm, 8 ft·lbf)**
  - Clutch Fluid (*1GR-FE Manual Trans Only*)
    - Refill with Toyota Dot 3 Brake Fluid.
    - Bleed the clutch system and torque the bleeder screws to spec.
    - **Torque Spec: 10.8 N·m (110 kgf·cm, 8 ft·lbf)**
- NOTE: 2TR-FE Manual Trans uses master cylinder reservoir for clutch.**
- Coolant
    - Refill with Toyota Long Life Coolant.
    - Bleed the cooling system.
  - Front Differential Fluid (*4WD Only*)
    - Install the **NEW** drain plug washer and torque to spec.
    - **Torque Spec: 64.7 N·m (660 kgf·cm, 48 ft·lbf)**
    - Refill with Hypoid Gear Oil API GL-5 75W-90.
    - Install the **NEW** filler plug washer and torque to spec.
    - **Torque Spec: 39.2 N·m (400 kgf·cm, 29 ft·lbf)**

### 3. START THE VEHICLE AND INSPECT THE FOLLOWING FOR LEAKS

- Fuel System
  - Start the engine and let it run for 5 seconds, then stop the engine and inspect for leaks. If there are no leaks, restart the engine and re-inspect.
- Cooling System
- Brake System
- Clutch System (*1GR-FE Manual Trans Only*)
- Front Differential System

### 4. RECHARGE THE A/C SYSTEM AND CHECK FOR PROPER OPERATION AND REFRIGERANT LEAKS

### 5. CHECK THE OPERATION OF THE FOLLOWING SYSTEMS AND ADJUST AS NEEDED



Make sure to follow the procedure outlined in the appropriate repair manual for the vehicle you are working on when checking, and if needed, adjusting the operation of the systems listed below. This is an important step, and must be performed thoroughly to ensure proper operation of these systems.

- Parking Brake Travel
- Shift Control Lever (*Automatic Trans Only*)
- Clutch Pedal (*Manual Trans Only*)

### 6. CHECK ALL FLUID LEVELS AND ADJUST AS NEEDED

NEW Replacement Parts			
Part #	Part Name	Kit #	Qty
95381-04045	Cotter Pin	3	2
43514-28010	Cap, front Axle Hub Grease, LH/RH	3	2

**7. TORQUE THE FRONT AXLE NUT (4WD ONLY)**

- a) Remove the front wheels.
- b) Torque the front axle nut to spec.

**Torque Spec: 235 N·m (2396 kgf·cm, 173 ft·lb)**

- c) Reinstall the lock cap with the **NEW** cotter pin.

**NOTE: If the holes for the cotter pin are not aligned, tighten the axle nut further, up to 60°.**

- d) Install the **NEW** grease cap.
- e) Repeat the procedure on the opposite side.
- f) Reinstall the front wheels and torque to spec.

**Torque Spec: 113 N·m (1152 kgf·cm, 83 ft·lbf)**

**8. PERFORM A WHEEL ALIGNMENT**

**9. CHECK THE HEADLIGHT AIM AND ADJUST AS NEEDED**

NEW Replacement Parts			
Part #	Part Name	Kit #	Qty
90080-11373	Bolt	8	4
90080-11373	Bolt	8	4

**10. REINSTALL THE ENGINE UNDER COVERS**

- a) Reinstall the engine under cover with 8 **NEW** bolts and torque to spec.

**Torque Spec: 30 N·m (306 kgf·cm, 22 ft·lbf)**

**11. CHECK FOR DTC'S AND REPAIR AS NEEDED**

**12. PERFORM INITIALIZATION**

**13. FINAL INSPECTION**

- a) Check the operation of the following systems:
  - 4WD System (*4WD Only*)
  - Interior Lights
  - Exterior Lights
  - HVAC System
  - Audio System
  - Power Windows
  - Power Door Locks
  - All Gauges, Indicators and Warning Lights
  - Etc.

**14. TEST DRIVE THE VEHICLE AND DOCUMENT FINAL REPAIR STATUS**

- a) Test drive the vehicle and perform final repair sign off with the [Frame Replacement Inspection Sheet](#). This must be performed and signed off by an MDT, Shop Foreman or Service Manager and retained with Final R.O.



## **V. APPENDIX**

As required by Federal Regulations, please make sure all recalled parts (original parts) removed from the vehicle are disposed of in a manner in which they will not be reused. Adequate time has been provided in the repair time to cut up and dispose of the perforated frame.

# Hole Plugs Installation Check Sheet

TRN220

for 4X2 Model (Short)

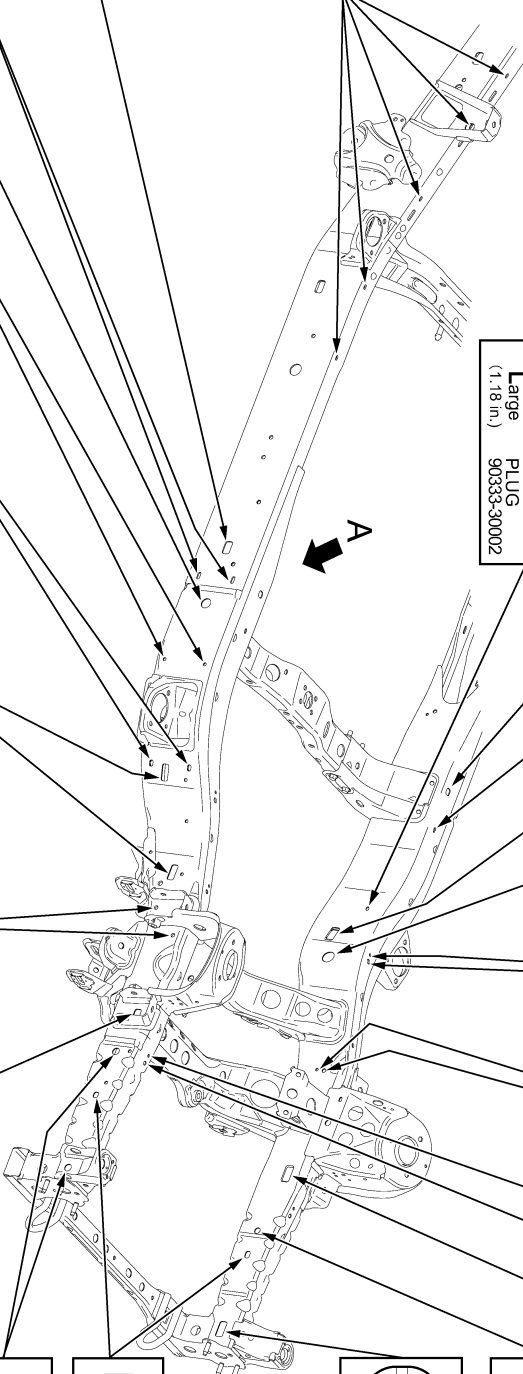
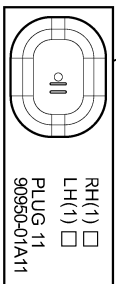
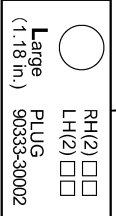
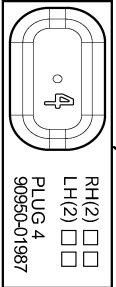
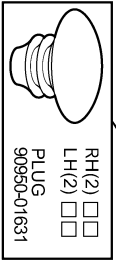
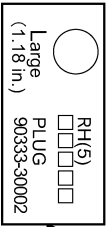
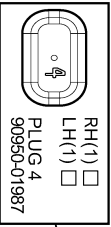
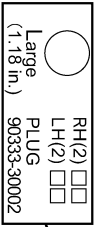
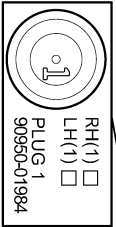
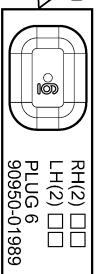
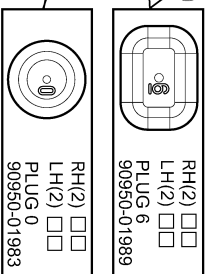
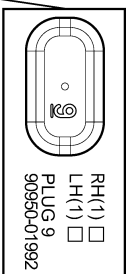
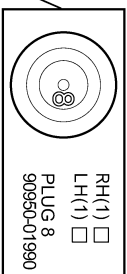
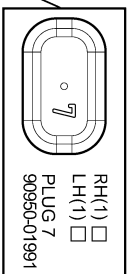
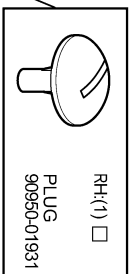
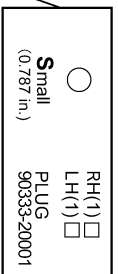
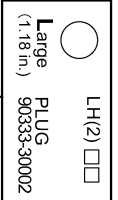
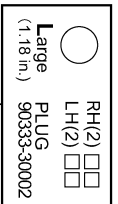
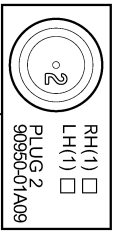
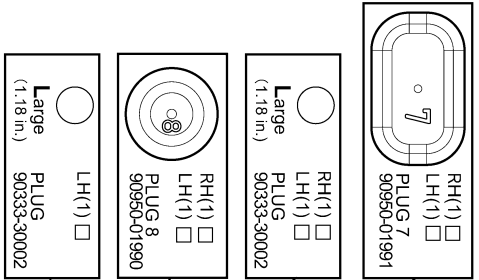
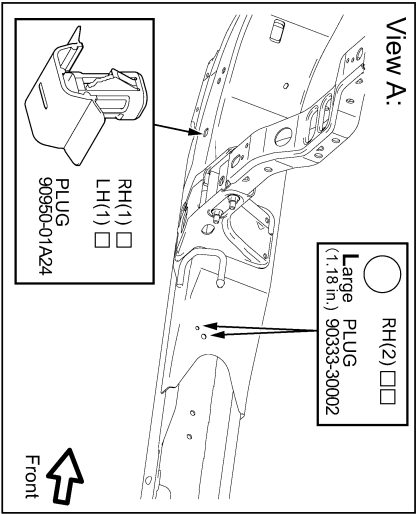

# Hole Plugs Installation Check Sheet

## TRN225, GRN225

for 4X2 Model (Ex-Long)

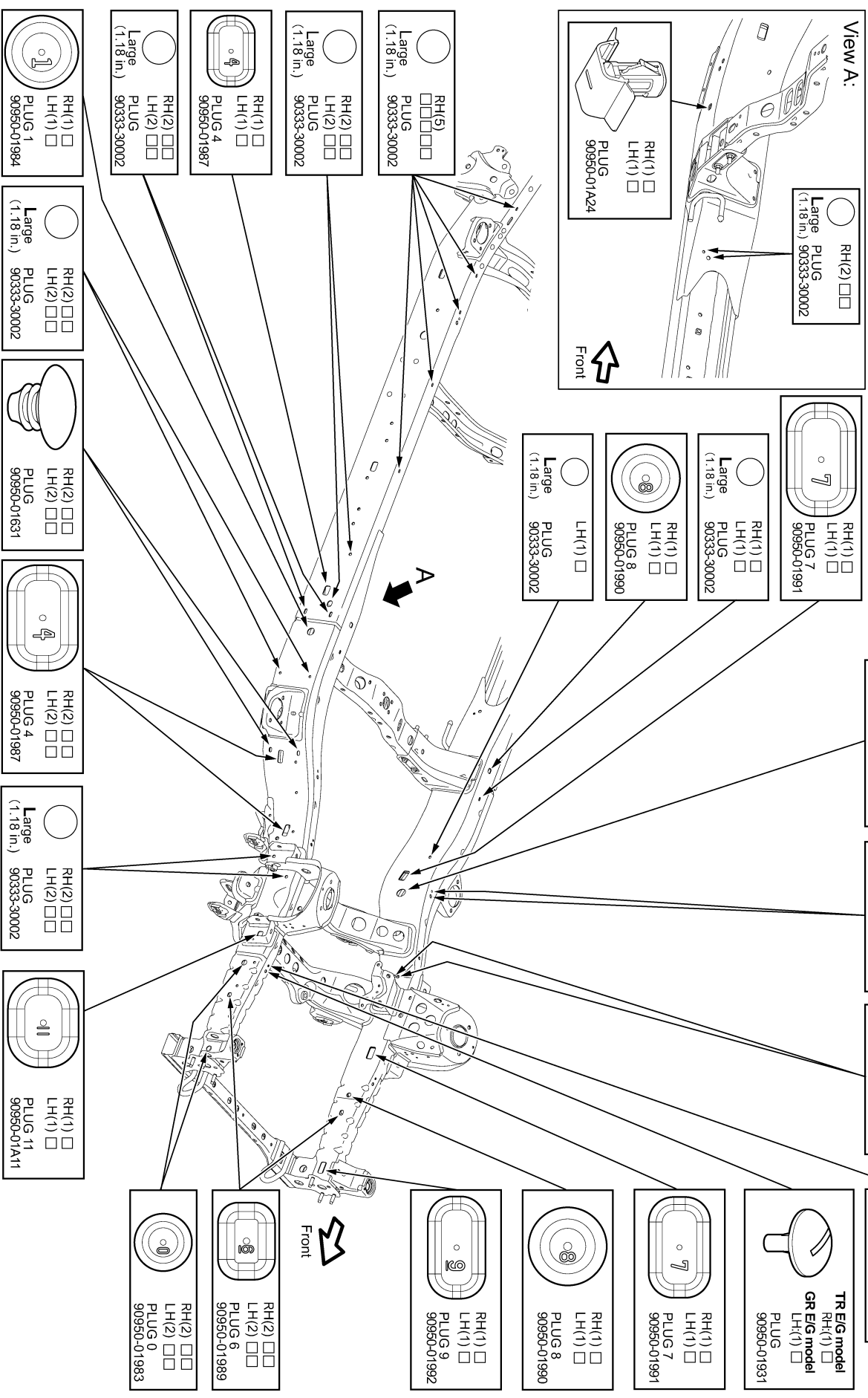

# Hole Plugs Installation Check Sheet

TRN240

for 4X4 & Pre-runner Model (Short)

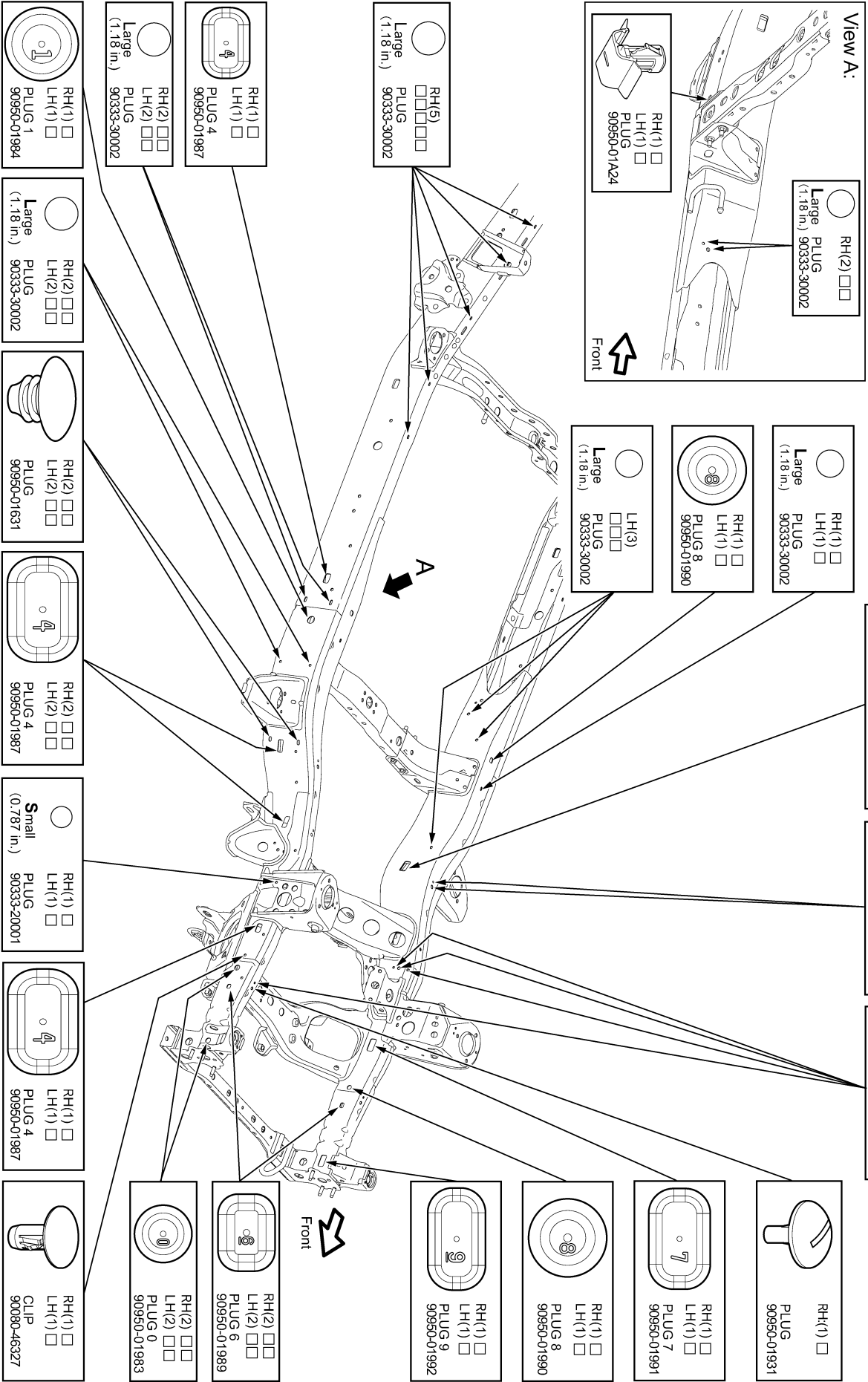



# Hole Plugs Installation Check Sheet

for 4X4 & Pre-runner Model (Super-Long)

GRN250.270

