

2020 LS500, LS500h Pre-Delivery Service (PDS)

Service Category General

Section Pre-Delivery Service

Market USA



Applicability

YEAR(S)	MODEL(S)	ADDITIONAL INFORMATION
2020	LS500, LS500H	

Introduction

This bulletin contains the vehicle specific pre-delivery services for 2020 model year LS500 and LS500h vehicles. Additionally, refer to the applicable Pre-Delivery Service (PDS) Check Sheet for services to be performed.

Warranty Information

OP CODE	DESCRIPTION	TIME	OFF	T1	T2
N/A	Not Applicable to Warranty	–	–	–	–

Procedures

- Front License Plate and Mounting Bracket Installation..... 2
- D/C Cut Fuse Installation 4
- Front and Rear Emergency Towing Eyelet Removal..... 8
- Front and Rear Emergency Towing Eyelet Hole Cover Installation 9
- Front Wheel Opening Extension Pad Installation 10

2020 LS500, LS500h Pre-Delivery Service (PDS)

Front License Plate and Mounting Bracket Installation

The front license plate mounting bracket and two self-tapping screws for the 2020 model year LS500 and LS500h are stored in the luggage compartment of the vehicle at the assembly plant. For states that require a front license plate, install the bracket and bolts on the bumper cover during PDS according to the following procedure.

1. Align holes "A" of the mounting bracket with the lower set of dimples on the front bumper cover.

NOTE

- There are two sets of dimples on the front bumper cover. Use the lower set of dimples.
- Holes "A" are used to install the mounting bracket onto the radiator grille.
- Holes "B" are used to install the front license plate onto the mounting bracket.

2. Install the mounting bracket onto the front bumper cover at holes "A" using the two self-tapping screws.

Figure 1.

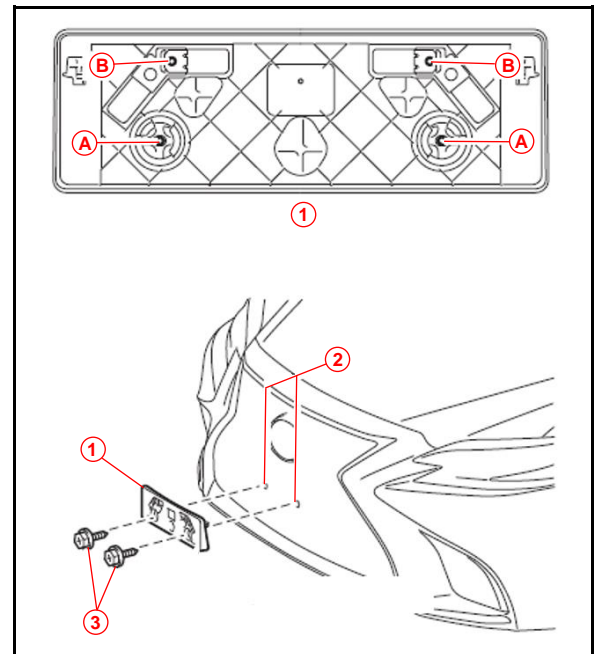

1	Mounting Bracket
2	Lower Dimple
3	Self-tapping Screw

2020 LS500, LS500h Pre-Delivery Service (PDS)

Front License Plate and Mounting Bracket Installation (continued)

3. Install the front license plate onto the mounting bracket at holes "B" using two noncorroding bolts with the following dimensions:

Nominal Length: 15.0 mm (0.59 in.)

Diameter: 6.0 mm (0.24 in.)

Figure 2.

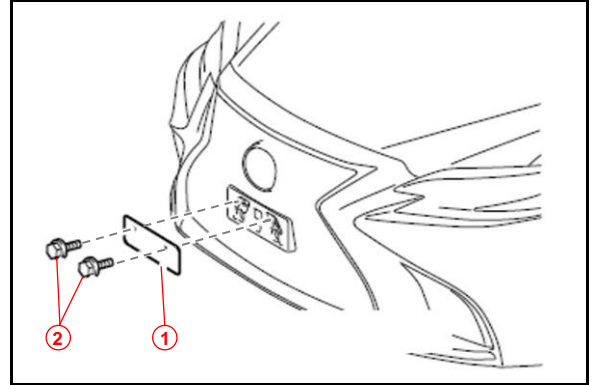

1	Front License Plate
2	Bolt

Figure 3.

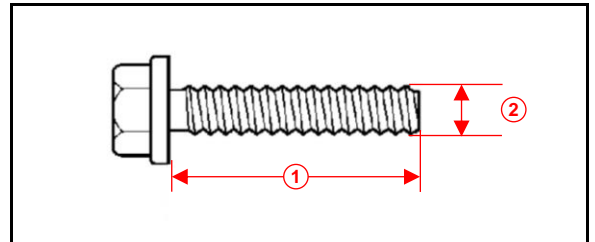

1	Nominal Length
2	Diameter

2020 LS500, LS500h Pre-Delivery Service (PDS)

D/C Cut Fuse Installation

To minimize battery discharge during transportation and storage, the D/C cut fuses (30A) have been removed at the assembly plant and temporarily stored in the blank spaces of the relay block in the engine compartment.

During PDS, remove the D/C cut fuses (30A) from the blank spaces of the relay block in the engine compartment and install them in the locations shown.

Gasoline Vehicles

With the ignition switch OFF, install the D/C cut fuses (30A) into their original locations in the engine compartment relay block.

Figure 4. Vehicles Without Active Stabilizer (Non-F Sport Models)

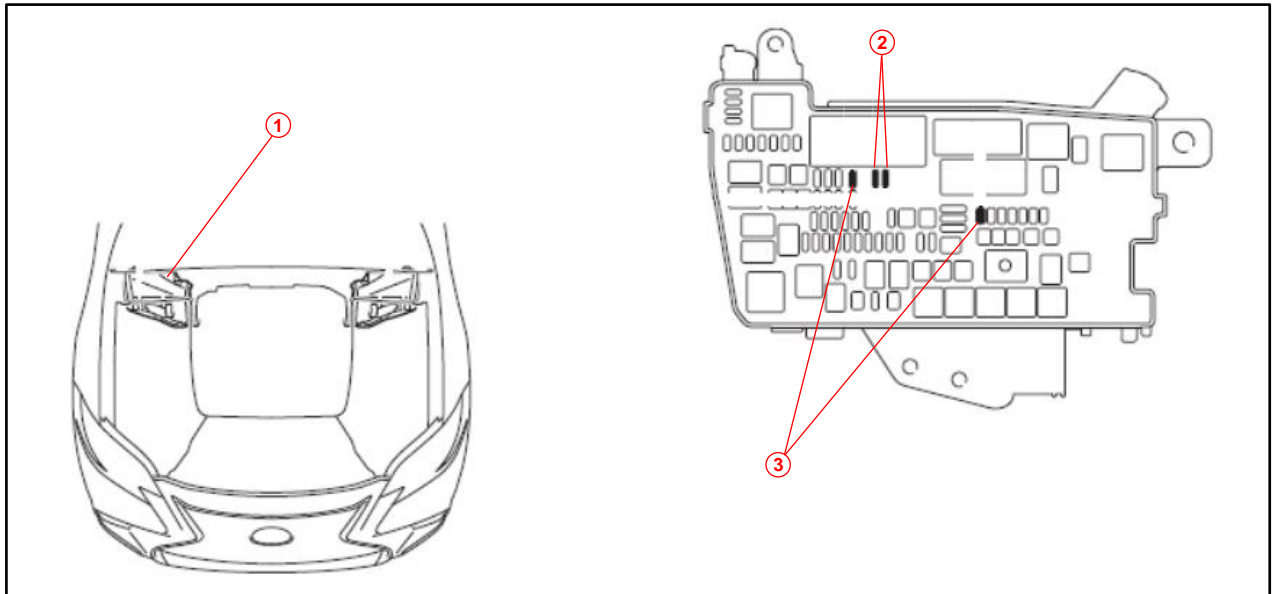

1	Relay Block
2	Remove These D/C Cut Fuses (30A)

3	Install D/C Cut Fuses (30A) Here (Original Location)
----------	---

NOTE

- While the vehicle is stored at the dealership, disconnect the negative (–) battery terminal to prevent battery discharge. Refer to Service Bulletin No. [L-SB-0013-19](#), *Battery Maintenance During PDS*.
- If the D/C cut fuses (30A) are installed with the ignition switch in the “IG-ON” position, Diagnostic Trouble Codes (DTCs) will be detected. Clear the DTCs.

2020 LS500, LS500h Pre-Delivery Service (PDS)

D/C Cut Fuse Installation (continued)

Gasoline Vehicles With Active Stabilizer System (F Sport Models)

1. Push the core of the engine compartment side cover clips and remove them.

2. Remove the engine compartment side cover (upper radiator support seal).

Figure 5.

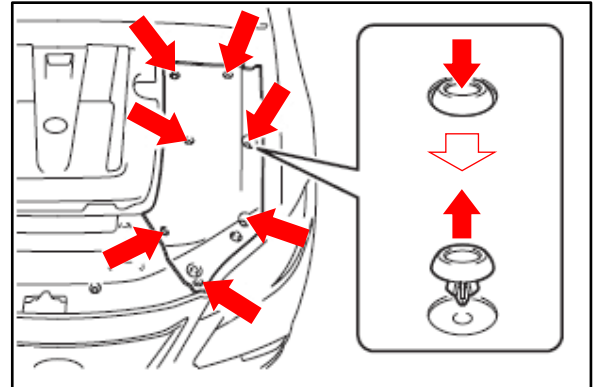

2020 LS500, LS500h Pre-Delivery Service (PDS)

D/C Cut Fuse Installation (continued)

Gasoline Vehicles With Active Stabilizer System (F Sport Models) (continued)

- With the ignition switch OFF, install the D/C cut fuses (30A) into their original locations in the engine compartment relay block.

Figure 6. Vehicles With Active Stabilizer Suspension System (F Sport)

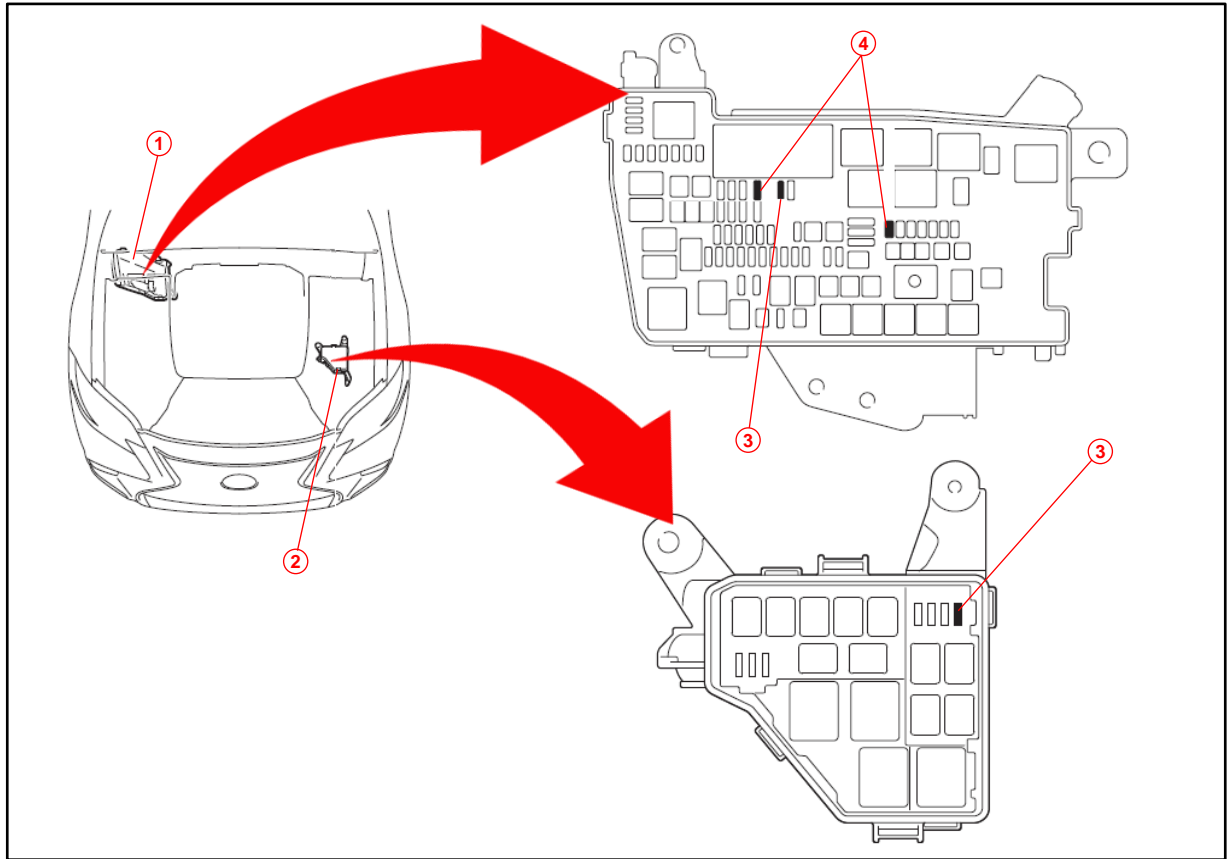

1	Main Relay Block
2	Sub Relay Block

3	Remove These D/C Cut Fuses (30A)
4	Install D/C Cut Fuses (30A) Here (Original Location)

NOTE

- While the vehicle is stored at the dealership, disconnect the negative (-) battery terminal to prevent battery discharge. Refer to Service Bulletin No. [L-SB-0013-19, Battery Maintenance During PDS](#).
- If the D/C cut fuses (30A) are installed with the ignition switch in the "IG-ON" position, DTCs will be detected. Clear the DTCs.

2020 LS500, LS500h Pre-Delivery Service (PDS)

D/C Cut Fuse Installation (continued)

Gasoline Vehicles With Active Stabilizer System (F Sport Models) (continued)

4. Reinstall the engine compartment side cover (upper radiator support seal).
5. Confirm the master warning light is OFF and there are no warning messages on the multi-informational display.

Hybrid Vehicles

With the ignition switch OFF, install the D/C cut fuses (30A) into their original locations in the engine compartment relay block.

Figure 7.

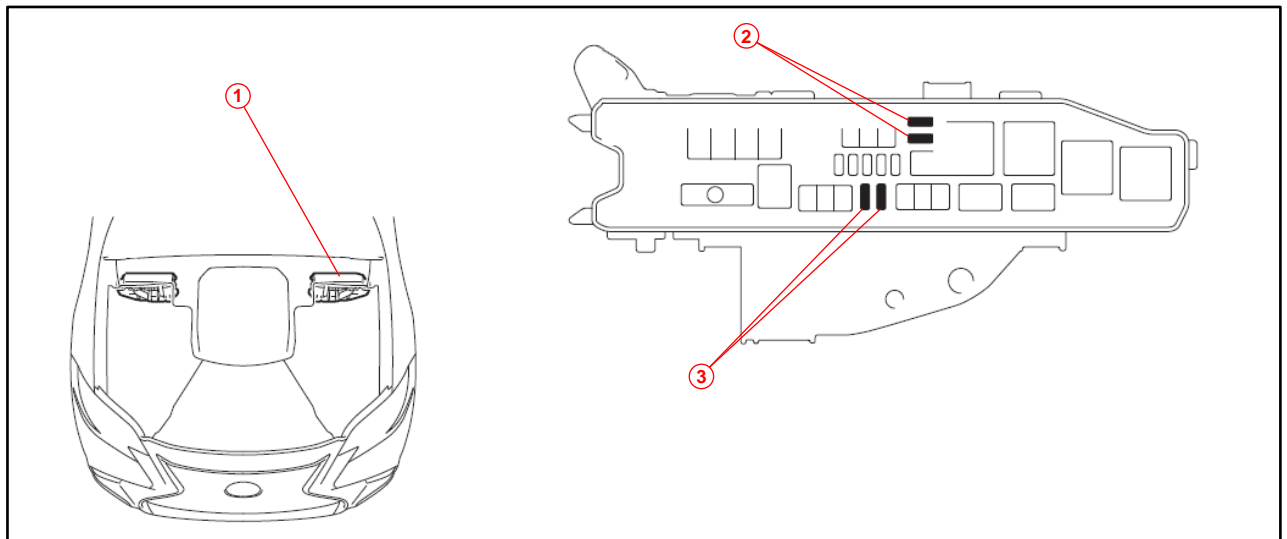

1	Main Relay Block (LHD)
2	D/C Cut Fuses (30A) (Storage Location)

3	Install D/C Cut Fuses (30A) Here
----------	---

NOTE

- While the vehicle is stored at the dealership, disconnect the negative (-) battery terminal to prevent battery discharge. Refer to Service Bulletin No. [L-SB-0013-19](#), *Battery Maintenance During PDS*.
- If the D/C cut fuses (30A) are installed with the ignition switch in the "IG-ON" position, DTCs will be detected. Clear the DTCs.

2020 LS500, LS500h Pre-Delivery Service (PDS)

Front and Rear Emergency Towing Eyelet Removal

1. Remove the front and rear emergency towing eyelets from the front and rear bumpers by turning them counterclockwise.

HINT

If it is difficult to loosen the front emergency towing eyelet, use a steel bar.

Figure 8.

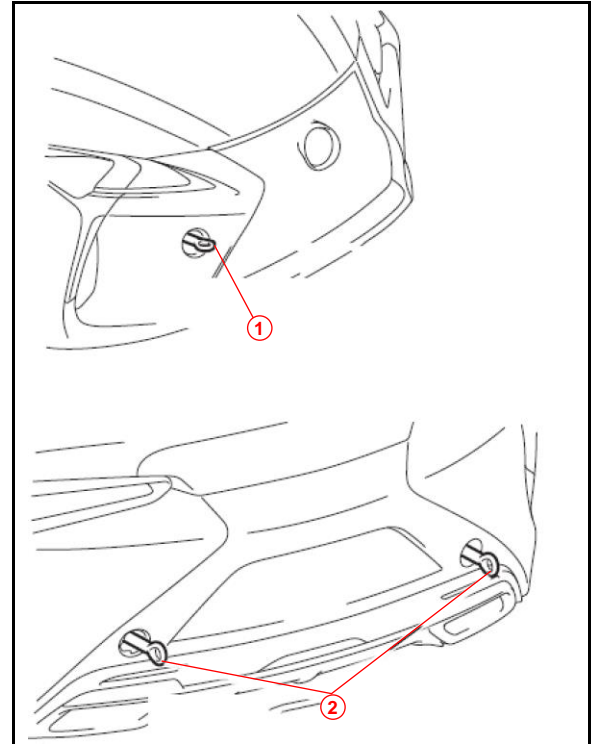

1	Front Emergency Towing Eyelet
2	Rear Emergency Towing Eyelet

2. Place one of the removed emergency towing eyelets into the luggage tray in the luggage compartment.

HINT

Dispose of the other removed emergency towing eyelets.

Figure 9.

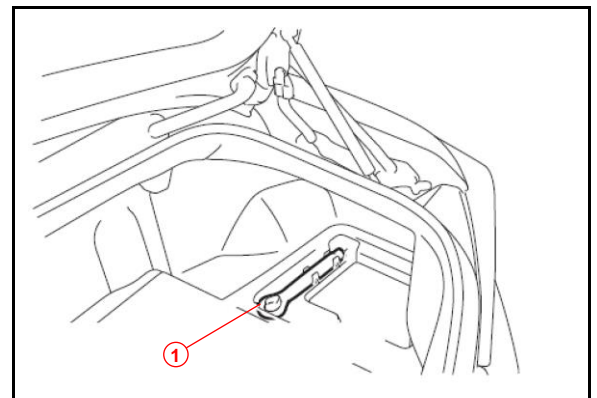

1	Emergency Towing Eyelet
----------	--------------------------------

2020 LS500, LS500h Pre-Delivery Service (PDS)

Front and Rear Emergency Towing Eyelet Hole Cover Installation

1. Install the front and rear emergency towing eyelet hole covers, which are stored in the glove compartment, onto the front and rear bumpers.
 - A. Insert the arrow-shaped part of the emergency towing eyelet hole cover "A" into the eyelet hole "B" as shown.
 - B. Install the emergency towing eyelet hole cover to the hole of the bumper.

HINT

Make sure the front emergency eyelet towing cover is installed in front, and the rear emergency eyelet towing cover is installed in the rear.

Figure 10.

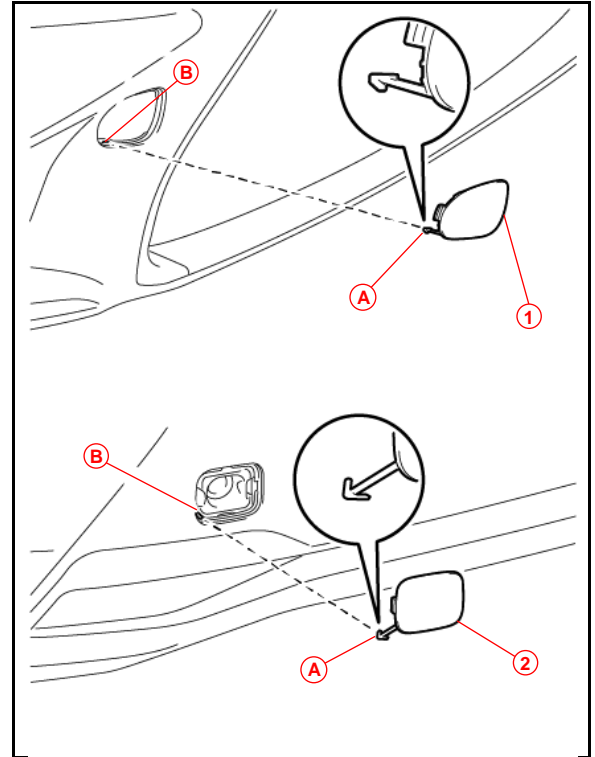

A	Arrow-shaped Part
B	Eyelet Hole
1	Front Emergency Towing Eyelet Hole Cover
2	Rear Emergency Towing Eyelet Hole Cover

2020 LS500, LS500h Pre-Delivery Service (PDS)

Front Wheel Opening Extension Pad Installation

The front wheel opening extension pad set (right and left front wheel opening extension pads and two self-tapping screws) is stored in the luggage compartment at the assembly plant to avoid damage in transit.

- Using the distinguishable mark on the pad, hook the retainers of the front left wheel opening extension pad through the installation holes on the fender liner and temporarily fix it to the installation position.

NOTE

There is a distinguishable mark on each pad indicating the left and right side pads.

- Tighten the two self-tapping screws.
- Repeat steps 1 and 2 to install the right front wheel opening extension pad.

Figure 11.

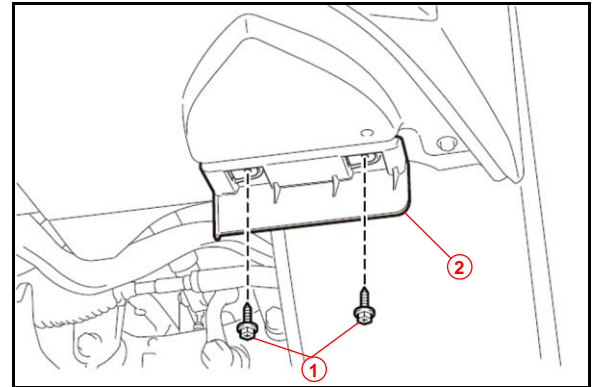

1	Self-tapping Screw
2	Front Wheel Opening Extension Pad