

PREVOST

Instruction Sheet

IS-19040A

POWER STEERING PUMP DISCHARGE HOSE (PRESSURE) REPLACEMENT

Revision: A
09-19-2019

Addition of kit #160122 in MATERIAL

Use this instruction sheet for the replacement of the following hoses: #161335P, #160039

Applicable to the following models: XLII Entertainer
X3-45 coaches & X3-45 Commuter
X3-45 VIP motorhomes
X3-45 VIP commercial use

Kit #160127 or #160122 are necessary at time of first installation as the new hose #160006 has a greater diameter than the former hose model installed, thus it is necessary to use new split block #504189.

MATERIAL

Kit #160127 (X3 Series, starting from vehicle D-5388) includes the following parts:

Part No.	Description	Qty
160006	HOSE, PRESSURE 11690 mm (460 inches), dia. 22 mm	1
500107	SCREW, TC HEX Z050 1/4-20x2	3
501031	SEAL, JIC 37° #8	1
504189	CLAMP, SPLIT BLOCK 22 mm/19 mm PA GROUP 3,	13
504728	RETAINER PLATE T3	3
FI-19040	FEUILLE D'INSTRUCTION	1
IS-19040	INSTRUCTION SHEET	1

Kit #160122 (X3 Series, up to vehicle D-5387 included) includes the following parts:

Part No.	Description	Qty
160006	HOSE, PRESSURE 11690 mm (460 inches), dia. 22 mm	1
1600100	FLANGE, POWER STEERING HOSE (wall mount split block half)	2
500107	SCREW, TC HEX Z050 1/4-20x2	3
501031	SEAL, JIC 37° #8	1
504189	CLAMP, SPLIT BLOCK 22 mm/19 mm PA GROUP 3,	13
504728	RETAINER PLATE T3	3
FI-19040	FEUILLE D'INSTRUCTION	1
IS-19040	INSTRUCTION SHEET	1

NOTE

Material can be obtained through regular channels.

PROCEDURE



DANGER

Park vehicle safely, apply parking brake, stop the engine. Prior to working on the vehicle, set the ignition switch to the OFF position and trip the main circuit breakers equipped with a trip button. On Commuter type vehicles, set the battery master switch (master cut-out) to the OFF position.

Lock out & Tag out (LOTO) must be performed during set-up, maintenance or repair activities. Refer to your local procedure for detailed information regarding the control of hazardous energy.

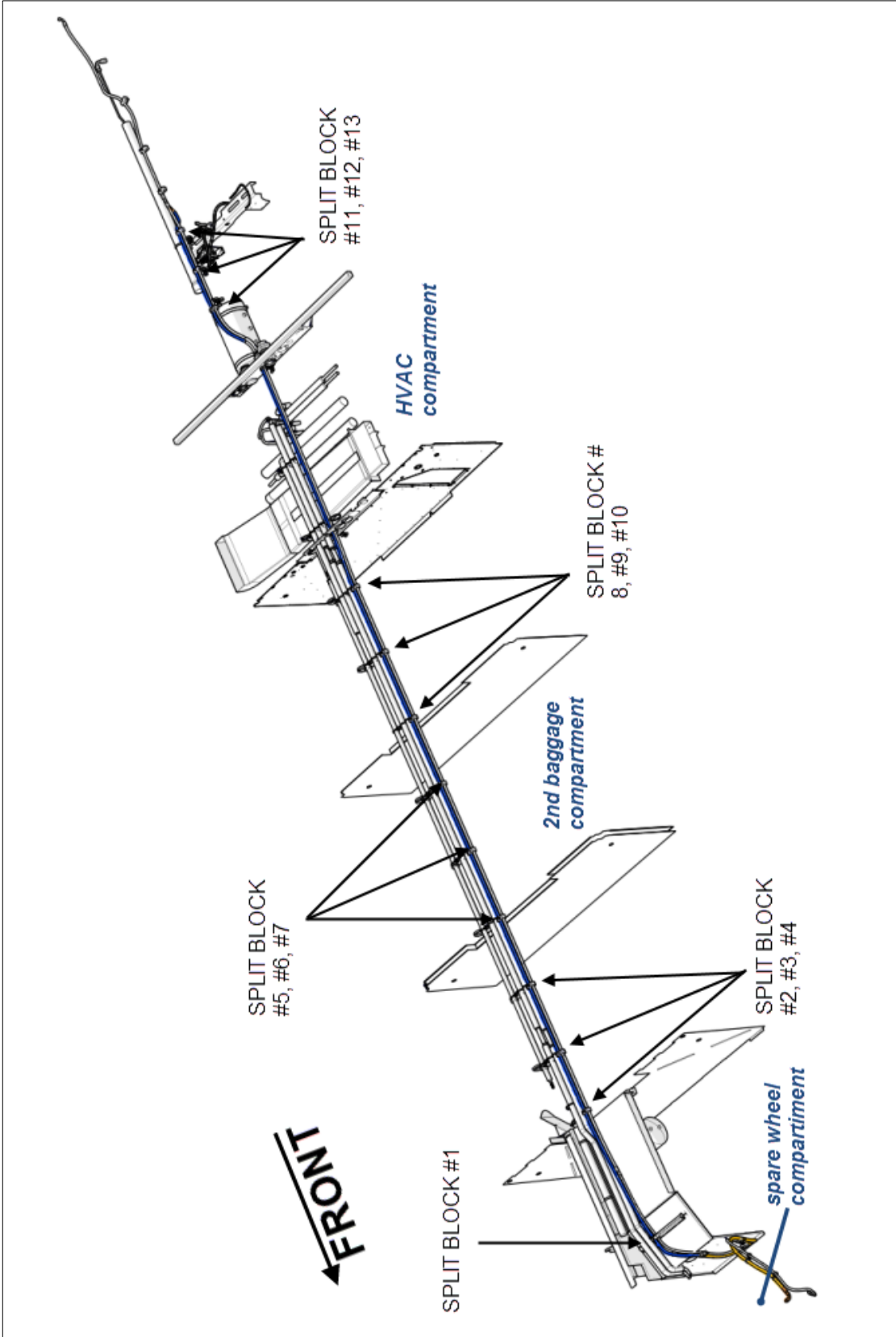

FIGURE 1 : POWER STEERING PUMP DISCHARGE HOSE (PRESSURE)

Wall mount split block - 2x p/n #1600100

X3 Series, up to vehicle D-5387 included.

One (1) split block designed to be mounted on a wall might be installed on your vehicle, depending on the model and year-model.

Take note that the new wall mount split block has two (2) 22 mm (7/8") passage holes. The power steering pump return hose has a diameter of 19 mm. You need to add a couple of tape layers around the return hose to make sure it is properly clamped in this split block.

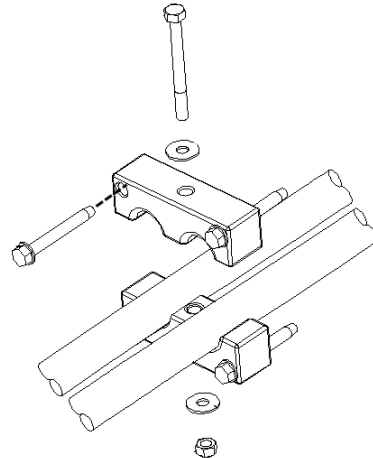

1. Turn off the engine and ensure that steering fluid has sufficiently cooled before starting the following procedure
2. Have a suitable container to collect the steering fluid under the steering gear.

3. Locate the discharge hose (pressure).

- In the spare wheel compartment, it is wrapped in a yellow sheath and is connected to the top of the steering box (fig.2).

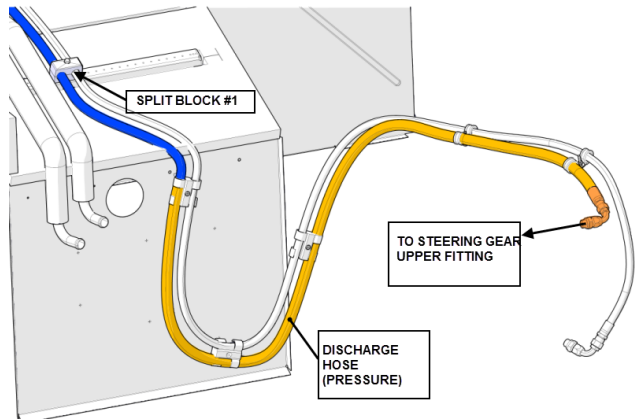

FIGURE 2

- In the rear wheel well, it is located on the curb side. It is connected to a hard section (metal pipe) from the steering pump (fig. 3). Search above the rear R.H. side air spring of the drive axle

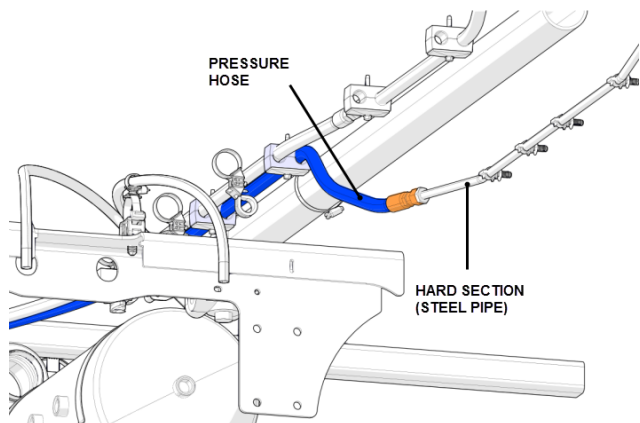

FIGURE 3

4. In the spare wheel compartment, separate the hose from the five (5) securing elements identified and remove the split block.

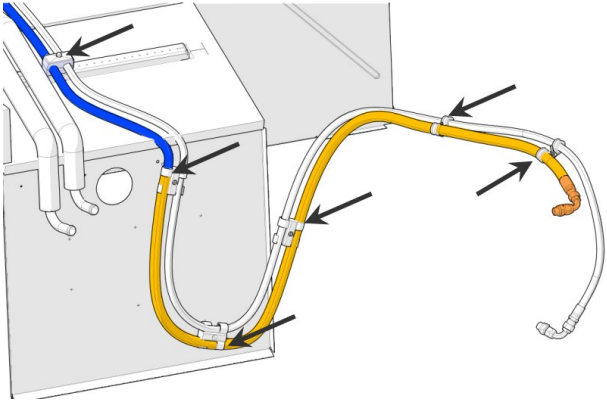

FIGURE 4 : TWO (2) P-CLAMPS, THREE (3) HOSE GUIDES, ONE (1) SPLIT BLOCK

5. In the front service compartment, place a container under the steering gear to collect the steering fluid that may drip.
6. Locate the straight fitting of the discharge hose (pressure) at the top of the steering gear.
7. Loosen the discharge hose (pressure) straight fitting while holding the elbow fitting with a wrench.

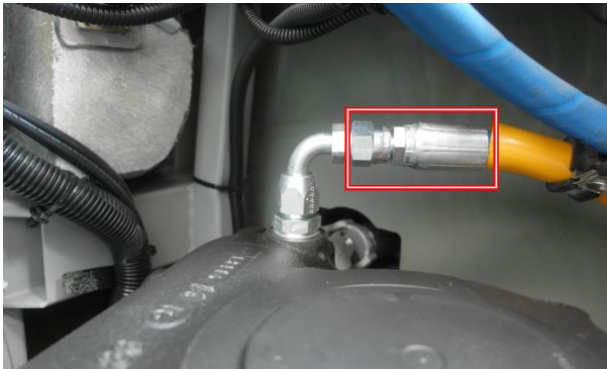

FIGURE 5

8. Drain the fluid from the hose in the container.

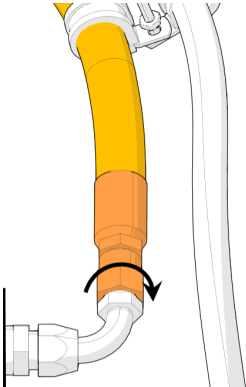

FIGURE 6

9. If a JIC 37 ° #8JIC-F plug is available, use it to plug the steering gear elbow fitting in order to avoid intrusion of dirt.



10. Locate the discharge hose (pressure) on the curb side of the rear wheel well. It is connected to a hard section (metal pipe) which is from the steering pump (fig.7).

Unscrew the fitting while holding the hard section (metal pipe) with a wrench.



If a JIC 37 ° #8JIC-F plug is available, use it to plug the hard section.

11. To avoid splashing, place the end of the hose that is located in the front service compartment in the container and drain the hose by injecting compressed air from the other end.

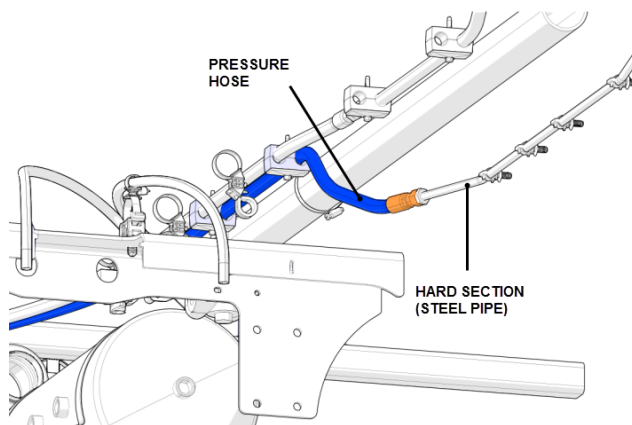

FIGURE 7

12. Remove thirteen (13) split blocks identified in figure 1. Note that split blocks 11, 12 & 13 are located at the top of the rear wheel well.

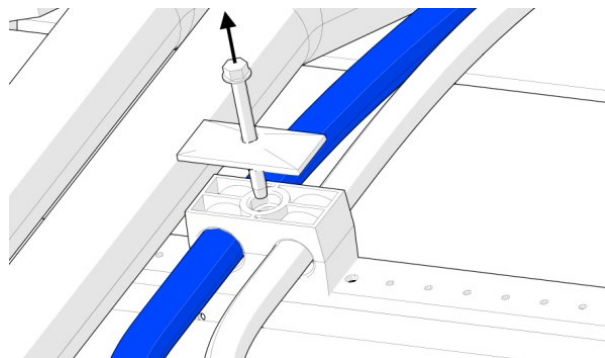

FIGURE 8 : SPLIT BLOCK #1 IN THE SPARE WHEEL COMPARTMENT

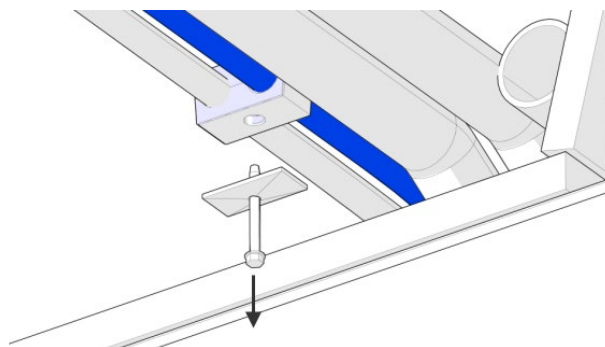

FIGURE 9 : OTHER TYPICAL SPLIT BLOCKS AT THE CEILING OF THE BAGGAGE COMPARTMENTS (9 LOCATIONS)

13. In the spare wheel compartment, join the old and new hose together with a male-male JIC 37 ° #8 union fitting. This will help guide the new hose in place while removing the old hose.

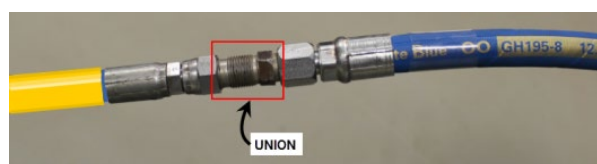

FIGURE 10

14. Begin to remove the old hose by pulling from the wheel well while a colleague helps feed the new hose from the spare wheel compartment.
15. Help the colleague in guiding the new hose in the baggage compartments, while he continues to remove the existing pipe.

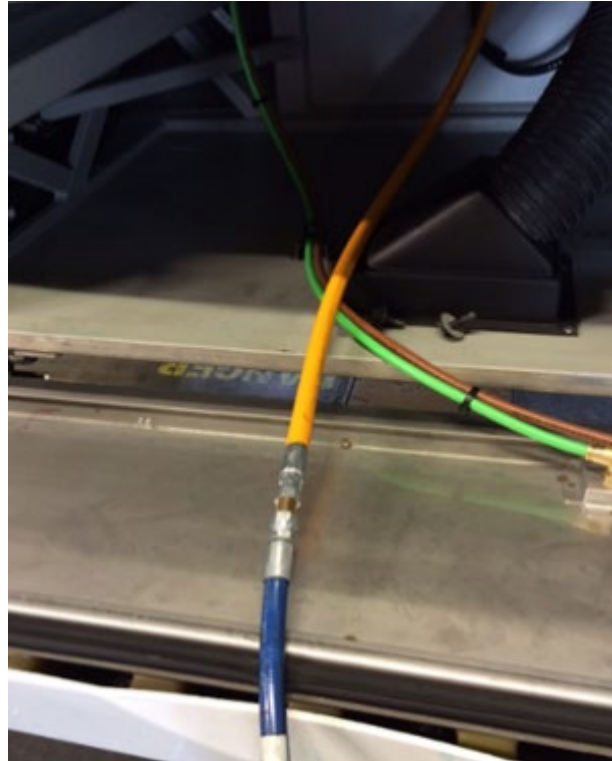

FIGURE 11

CONNECTION TO THE HARD SECTION

16. Inspect the sealing surfaces. Clean and dry the fitting.
17. Place seal #501031 on the fitting of the rigid section.
18. Apply red Loctite on the JIC fitting threads only. Take care not to put Loctite on the conical part (flare) of the fitting or inside the hose.
19. Tighten the fitting by hand, then with a 7/8 open wrench, tighten the fitting by turning it 90° further while holding the other hexagonal section with a wrench.

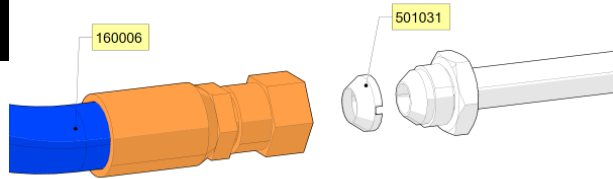

FIGURE 12

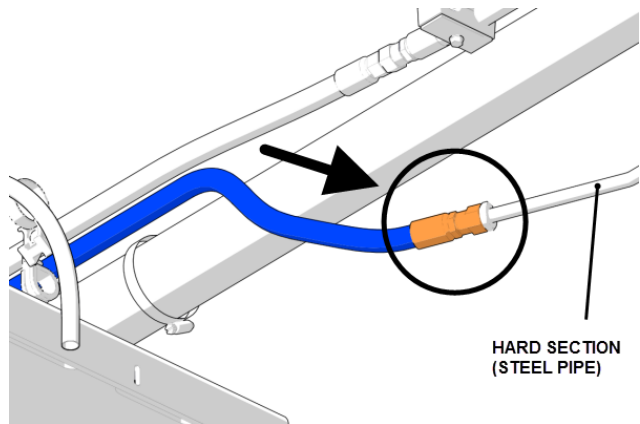

FIGURE 13



CONNECTION TO THE STEERING GEAR

20. Inspect the sealing surfaces. Clean and dry the fitting.
21. Apply red Loctite on the JIC fitting threads only. Take care not to put Loctite on the conical part (flare) of the fitting or inside the hose.
22. Tighten the fitting by hand, then with a 7/8 open wrench, tighten the fitting by turning it 90° further while holding the other hexagonal section with a wrench.

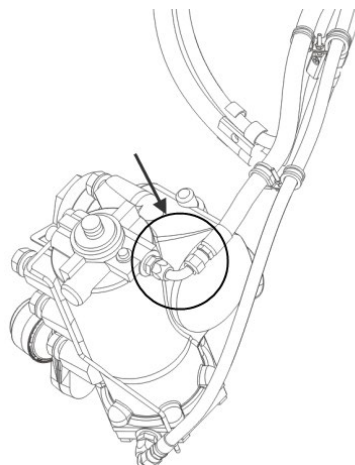

FIGURE 14



23. From the spare wheel compartment, pull on the hose to stretch and move 'slack' in this compartment.
24. Install the new thirteen (13) split blocks #504189 (figure 1 & 15). Reuse the retainer plates and existing screws except for the split blocks #11, #12 & #13 located in the rear wheel well where the existing hardware is more likely to be corroded.

Note: make sure that the new hose is placed in the 22 mm (7/8") diameter housing.



FIGURE 15

25. In the compartment spare wheel, secure the discharge hose (pressure) as previously arranged.

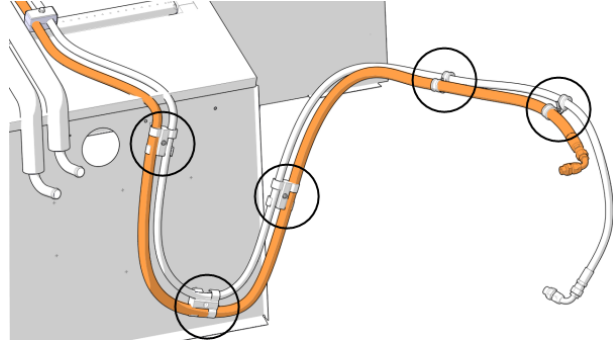

FIGURE 16 : TWO (2) P-CLAMPS, THREE (3) HOSE GUIDES

FLUID FILLING AND BLEEDING

26. Remove the tank cover and place the nut on the spring to maintain normal pressure on the filter in the tank.
27. Fill the tank with fluid up to 2 inches from the top of the tank (only to prevent spills).
28. Start the engine and have it run at idling speed to fill the steering system with fluid. During this operation, the fluid level in the tank will quickly drop. Therefore, to avoid any suction of air, the fluid tank has to be topped up constantly.



FIGURE 17

BLEEDING

29. FOR STEERING GEAR VERSIONS WITH AUTOMATIC BLEEDING ...

Steering gear versions with automatic bleeding do not have any bleed screws. These steering gears automatically bleed any air remaining within the steering system. Proceed as follows :

- a) Lift the front of the vehicle so that the wheels are not on the ground.
- b) Start the engine and have it run at idling speed for 2-3 minutes. Ask a colleague to turn the wheel from one knuckle stop to the other until the effort needed is constant, so the air will be evacuated by the steering fluid reservoir. Monitor the fluid level in the tank.
- c) After bleeding, fill the tank up to 1" from the top of the tank. Check the fluid level with the dipstick.

30. STEERING GEAR WITH BLEEDER/BLEEDER SCREW

Refer to paragraph **5.4.3 Bleeding** of RB Robert Bosch Servocom Service Manual (8090) available on the Technical Publications site.

<https://techpub.prevostcar.com/en/download?id=352&type=publications>

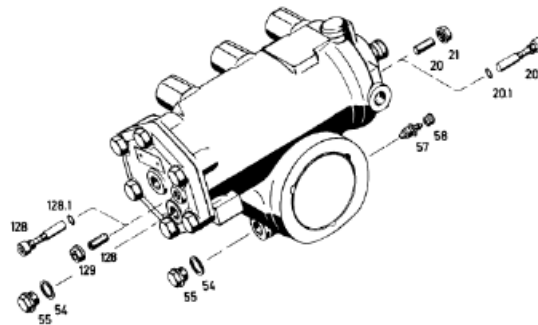
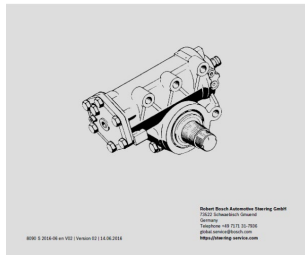
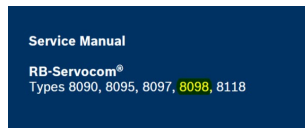

FIGURE 18 : BLEEDER (item 57) & BLEED SCREWS

31. Inspect the connections to make sure that there are no leaks at the fittings.

32. Check the good operation of the system by performing a test drive.

PARTS / WASTE DISPOSAL

Discard waste according to applicable environmental regulations (Municipal/State[Prov.]/ Federal)