

SERVICE PROCEDURE

19510
SEPTEMBER 2019

SUBJECT: SAFETY RECALL
**Shield Two-Point Lap Belt on certain 2011 IC Bus®
BE, CE and RE school buses built 22 March 2010
thru 07 September 2010 with non-retractable
passenger two-point lap belts by Amsafe / Shield**

DEFECT DESCRIPTION

Long term cycle fatigue (buckling and unbuckling the seat belt) may cause the plastic fingers on the male portion of the buckle to crack and break off resulting in an increase in force necessary to latch the seat belt buckle.

MODELS INVOLVED

This Safety Recall involves certain 2011 IC Bus® BE, CE and RE model school buses built 22 March 2010 thru 07 September 2010 with non-retractable passenger two-point lap belts by Amsafe / Shield.

ELIGIBILITY

This procedure applies ONLY to vehicles marked in the International® Service PortalSM with Safety Recall 19510. Also complete any other open campaigns listed on the Service Portal at this time.

PARTS INFORMATION

Part Number	Part Description	Quantity
8900283R91	Kit for Blue Seat Belts	As Required
8900284R91	Kit for Maroon Seat Belts	As Required
8900285R91	Kit for Brown Seat Belts	As Required

8900283R91 contains the following parts:

Part Description	Quantity
Blue Seat Belt	1
BOLT, HEXAGON FLANGE W/LOCK WASHER	1
NUT HEXAGON FLANGE 3/8-16 GRADE 8	1

8900284R91 contains the following parts:

Part Description	Quantity
Maroon Seat Belt	1
BOLT, HEXAGON FLANGE W/LOCK WASHER	1
NUT HEXAGON FLANGE 3/8-16 GRADE 8	1

8900285R91 contains the following parts:

Part Description	Quantity
Brown Seat Belt	1
BOLT, HEXAGON FLANGE W/LOCK WASHER	1
NUT HEXAGON FLANGE 3/8-16 GRADE 8	1

SERVICE PROCEDURE

WARNING! To prevent personal injury, and / or death, or damage to property, park vehicle on hard flat surface, turn the engine off, set the parking brake and install wheel chocks to prevent the vehicle from moving in either direction.

WARNING! To prevent personal injury, and / or death, or damage to property, if the vehicle must be raised, do not work under the vehicle supported only by jacks. Jacks can slip or fall over.

WARNING! To prevent personal injury and / or death, always wear safe eye protection when performing vehicle maintenance.

WARNING! To prevent personal injury, and / or death, or damage to property, keep flames, sparks or other heat sources away from vehicle and do not smoke while servicing the vehicle's batteries. Batteries expel gases which may cause an explosion resulting in personal injury and / or death, or damage to property, avoid contact with any heat sources.

1. Park vehicle on flat surface.
2. Shift transmission to Park or Neutral and set parking brake.
3. Turn vehicle ignition to Key OFF position.
4. Install wheel chocks.



0000457703

Figure 1. Seat Belt Latches

1. Top push release belt latch (rectangle button)
 2. Side push release belt latch (square button)
5. Inspect all seat belts on vehicle:
- a. If seat belt is equipped with a top push release belt latch (Figure 1, Item 1), proceed to Step 6.
 - b. If seat belt is equipped with a side push release belt latch (Figure 1, Item 2), proceed to Step 13.

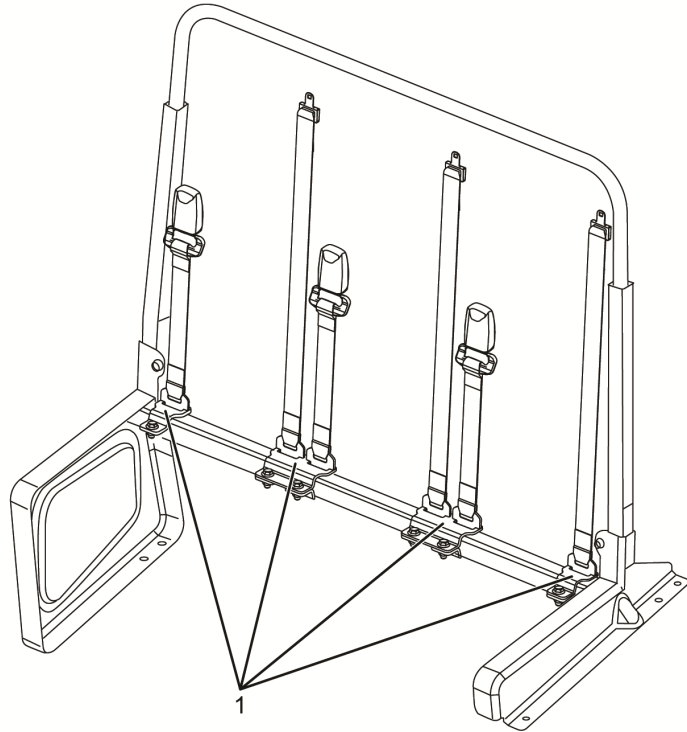

0000457723

Figure 2. Seat Belt Bracket

1. Seat belt bracket
6. Unlatch and raise bottom seat cushion to gain access to seat belt brackets (Figure 2, Item 1).

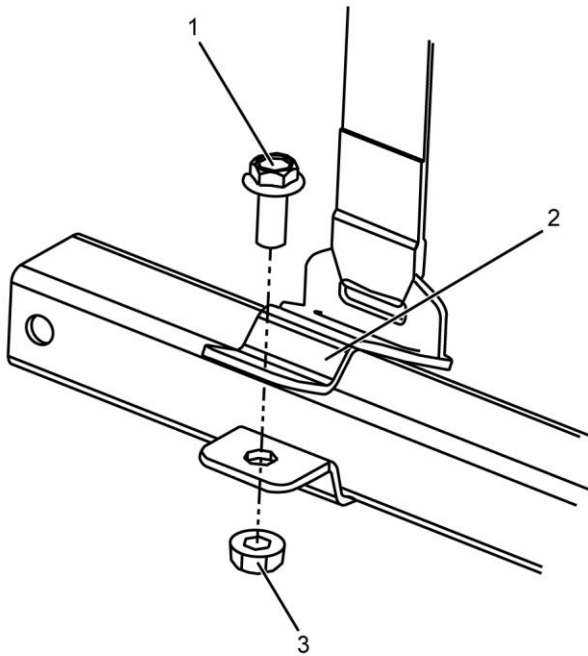

0000457743

Figure 3. Seat Belt Components

1. Bolt
2. Bracket
3. Nut

7. Remove and discard bolts (Figure 3, Item 1) and nuts (Figure 3, Item 3) securing seat belt bracket (Figure 3, Item 2) to bus seat frame.

NOTE: When replacing the seat belt, make sure to replace with the same color belt assembly.

8. Remove and discard seat belt from bus seat frame.

NOTE: The replacement seat belts have a shorter tether on the female side of the seat belt than the original seat belt. The overall length of the belt will not change.

9. Install new seat belt onto bus seat frame.
10. Install seat belt bolts and nuts, using a torque wrench, tighten to 30 - 38 lb-ft (41 - 52 N•m).
11. Lower and latch bottom seat cushion after all top push release belts are replaced for seat.

12. Repeat Steps 6 through 11 until all necessary seat belts have been replaced.
13. Remove wheel chocks.

END OF SERVICE PROCEDURE

LABOR INFORMATION

Operation Number	Description	Time
A40-19510-1	Inspect and Replace Seat Belts; First Seat (3 Seat Belts)	0.4 hr
A40-19510-2	Inspect and Replace Seat Belts; Each Additional 3 Seats or 9 Seat Belts	0.2 hr

CAMPAIGN IDENTIFICATION LABEL

Each vehicle corrected in accordance with this campaign must be marked with a CTS-1075 Campaign Identification Label.

Complete the label and attach on a clean surface next to the vehicle identification number (VIN) plate.



ADMINISTRATIVE / DEALER RESPONSIBILITIES

WARRANTY CLAIMS

Warranty claim expense is to be charged to Warranty. Claims are to be submitted in the normal manner, making reference to Safety Recall 19510.

Section 7 of the Warranty Policy and Procedures Manual contains further information related to the submission and processing of AFC / Recall claims.

As with all claim submissions, items acquired locally must be submitted in the "Other Charges" tab. The cost of any bulk items (such as a bag of cable tie straps, roll of wire, barrel of oil, or tube of silicone) should be prorated for the cost of the individual pieces / amount used during each repair.

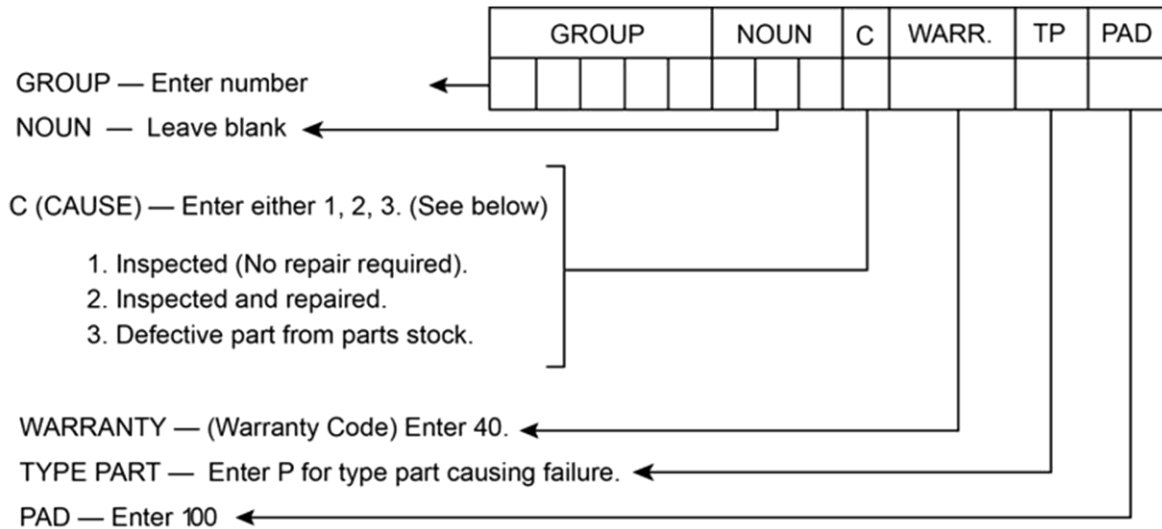

0000047910

UNITED STATES AND POSSESSIONS

The National Traffic and Motor Vehicle Safety Act, as amended, provides that each vehicle that is subject to a vehicle recall campaign must be adequately repaired within a reasonable time after the owner has tendered it for repair. A failure to adequately repair within 60 days after a tender of a vehicle is prima facie evidence of failure to repair within a reasonable time. If the condition is not adequately repaired within 60 days, the owner may be entitled to replacement with an identical or reasonable equivalent vehicle at no charge, or to a refund of the purchase price less a reasonable allowance for depreciation.

Dealers must correct all vehicles subject to this campaign at no charge to the owner, regardless of mileage, age of vehicle, or ownership, from this time forward.

Dealers should proceed immediately to make necessary correction to units in inventory. All inventory vehicles subject to this recall campaign must be corrected prior to sale, transfer or delivery. If vehicles have been sold or transferred and you are in receipt of Customer Notification Letters and Authorization for Recall Service cards for those vehicles, the transfer location or customer must be notified immediately from your dealer location.

Dealers must make every effort to promptly schedule an appointment with each owner to repair his or her vehicle as soon as possible. However, consistent with the customer notification, dealers are expected to complete the repairs on the mutually agreed upon service date.

Dealers involved in the recall process will be furnished a listing of owner names and addresses to enable them to follow up with owners and have the vehicles corrected. Use of this listing must be limited to this campaign because the list may contain information obtained from state motor vehicle registration records, and the use of such motor vehicle registration data for purposes other than this campaign is a violation of law in several states.

CANADA

Dealers must correct all vehicles subject to this campaign at no charge to the owner, regardless of mileage, age of vehicle, or ownership, from this time forward.

Dealers should proceed immediately to make necessary correction to units in inventory. All inventory vehicles subject to this recall campaign must be corrected prior to sale, transfer or delivery. If vehicles have been sold or transferred and you are in receipt of Customer Notification Letters and Authorization for Recall Service cards for those vehicles, the transfer location or customer must be notified immediately from your dealer location.

Dealers must make every effort to promptly schedule an appointment with each owner to repair his or her vehicle as soon as possible. However, consistent with the customer notification, dealers are expected to complete the repairs on the mutually agreed upon service date.

Dealers involved in the recall process will be furnished a listing of owner names and addresses to enable them to follow up with owners and have the vehicles corrected. Use of this listing must be limited to this campaign because the list may contain information obtained from state motor vehicle registration records, and the use of such motor vehicle registration data for purposes other than this campaign is a violation of law in several states.

EXPORT

Export Distributors should proceed immediately to make necessary correction to units in inventory. All inventory vehicles subject to this recall campaign must be corrected prior to sale, transfer or delivery. If vehicles have been sold or transferred and you are in receipt of Customer Notification Letters and Authorization for Recall Service cards for those vehicles, the transfer location or customer must be notified immediately from your distributor location.

Export Distributors are to submit warranty claims in the usual manner making reference to this recall number.

Export Distributors are expected to provide full cooperation and follow-up with respect to this important subject matter. If you have any questions or need further assistance, please contact the Regional Service Manager at your regional office.

NAVISTAR, INC.