

Constellation > 4900 Models
 Heritage > 5700 Models
 > 4700 Models > 6900 Models
 > 4800 Models

General Information

Some Powernet Distribution Box (PNDB) modules may experience poor fuse retention on the keep-alive circuits. This could cause intermittent operation of any devices supplied by these circuits. On units equipped with remote sense, it could result in the alternator overcharging, even on alternators capable of self-regulating.

NOTE: A self-regulating alternator may substitute the voltage reading from its primary battery positive, in the event that the remote sense line is a constant open circuit.

If the fuses are not seating properly on the keep-alive circuits, or are falling out, use the instructions in this bulletin to replace the PNDB. The PNDBs have been updated with product improvements to both the fuse terminals and to the case fuse cavities to fix the fuse retention concern. In addition, the PNDB firmware has been updated to prevent unintended opening of the internal electrical contacts.

The updated PNDB has new "A66" part numbers and its descriptions are given in the below, See [Table 1](#) and [Table 2](#). The original PNDB part numbers have been superseded within the DTNA Parts System to the correct corresponding PNDB "A66" part number. Updated PNDBs with internal Low Voltage Disconnect (LVD) are also available.

PNDB Base Number	Description
A66-03712	Main PNDB, no Cut Off Switch
A66-03713	AUX PNDB, no Cut Off Switch
A66-03714	Main PNDB, with Cut Off Switch
A66-03715	AUX PNDB, with Cut Off Switch
A66-03716	Main PNDB, with Cut Off Switch
A66-03717	Main PNDB, no Cut Off Switch

Table 1, PNDB Base Number and Description

New Low Voltage Disconnect PNDB Base Number	Description
A66-03718	12.2 LVD and Alarm
A66-03719	12.2 LVD

Table 2, New Low Voltage Disconnect PNDB Base Number and Description

Powernet Distribution Box (PNDB) Replacement

1. Park the vehicle on a level surface, shut down the engine and set the parking brake. Chock the tires.

NOTE: The powernet distribution box (PNDB) is located on the cab frontwall, above the main ground junction block. See [Fig. 1](#).

2. Disconnect all batteries. If the vehicle is equipped with an auxiliary battery bank, disconnect these batteries as well.
3. Open the hood.

IMPORTANT: Inspect the keep-alive and cab load disconnect switch (CLDS) connectors and make sure that the plugs are in unused connector cavities. Install plugs to seal the connector if any are missing.

4. Disconnect the cab load disconnect switch (CLDS) connector, if equipped.

5. Disconnect the keep-alive circuit connector from the PNDB.
 - 5.1 Using a flat-head screwdriver, push the red locking tab up.
 - 5.2 Press and release the tab, then remove the connector. See **Fig. 2**.

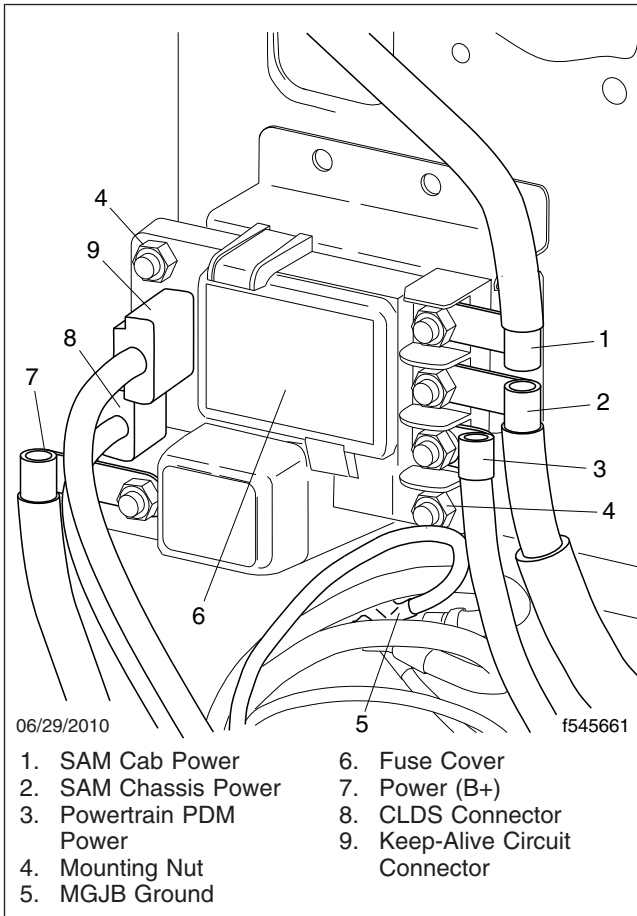

Fig. 1, Powernet Distribution Box (PNDB)

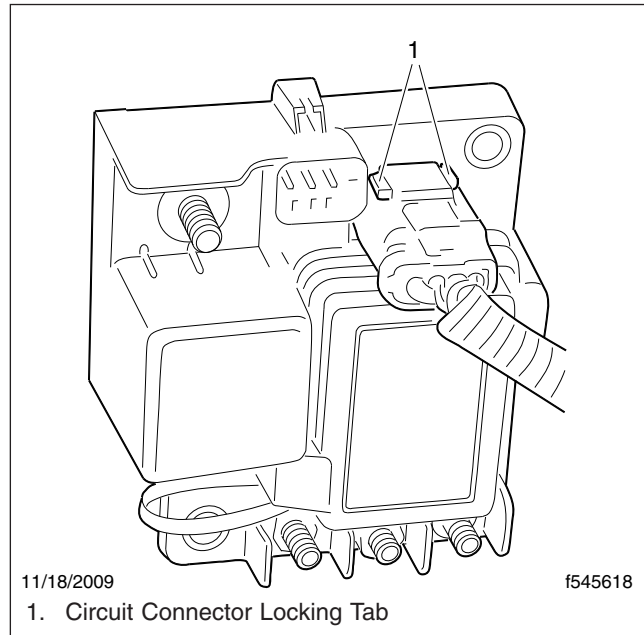

Fig. 2, Removing the Circuit Connector

6. Disconnect the power cables from the PNDB.
7. Remove the two mounting nuts.
8. Remove the PNDB.
9. Position the new PNDB on the frontwall, and attach the two mounting nuts.
10. Attach the keep-alive circuit connector and connect the CLDS switch, if equipped.
11. Connect the power cables. Torque the nut 15 lbf-ft (20 N·m).
12. Connect all batteries, including the auxiliary batteries, if equipped.
13. Close the hood.

Constellation > 4900 Models
 Heritage > 5700 Models
 > 4700 Models > 6900 Models
 > 4800 Models

Warranty

This procedure is warrantable only if the described condition exists and the repair is performed within the applicable base or extended coverage warranty period. If a failure is not found, this procedure is considered preventive and warranty does not apply.

Normal warranty applies. See [Table 3](#) for OWL VMRS codes and labor allowance information.

OWL VMRS Codes and Labor Allowance					
Primary Failed Part	Component Code	Cause Code	SRT Code	Description	Time: Hours
Powernet Distribution Box	034-004-181	23	285-5025A	Powernet Distribution Box, Inspection, R/R	0.5

Table 3, OWL VMRS Codes and Labor Allowance