



SIB 52 06 19

2019-08-28

SECOND ROW MECHANICAL 60/40 REAR SEAT NOISE DIAGNOSIS

MODEL

E-Series	Model Description
G05	(X5 Sports Activity Vehicle)
G06	(X6 Sports Activity Vehicle)

SITUATION

This bulletin addresses multiple customer noise complaints heard/felt in the 2nd row seats. These repairs are for the mechanical second row 60/40 Bench Seat. This includes the following concerns:

1. Interference noise (clattering, rattling) from the 2nd row of seats, between the 40% and 60% rear seat backrest on rough road surfaces.
2. Backrest unlocking function does not work and causes noises.
3. Backrest locking (top, bottom) rattles on rough road surfaces without load.
4. Squeaking noises from the rear seat bench (left and right) when loaded.
5. Groaning noise when entering and exiting.
6. Unlocking in the luggage compartment, Bowden cable in the luggage compartment does not work and causes interference noises.

Due to the elimination of the NED (Non-Electrical Diagnosis) test plan for seat noise from ISTA, we are releasing this bulletin.

CAUSE

Each of these concerns have their own individual cause:

1. Missing, damage plastic bushing (white) at 40% backrest. Collision with the 60% backrest.
2. Backrest unlocking Bowden cable disengaged / damaged. Indicator for the lock visible (red).
3. Unfavorable tolerances in the lock (top, bottom) cause interference noises.
4. Trim wire has become detached from the foam structure.
5. Missing anti-groaning noise web structure at the entry sill accentuates the groaning noise.
6. Unlocking in the luggage compartment, grouting in the clutch not OK and routing of the Bowden cable is not correct.

CORRECTION

In the event of a customer complaint, proceed as follows.

1. Replace plastic pivot bushing.
2. Replace Bowden cable.
3. Replace the top and bottom lock of the backrest.
4. Replace the foam part(s) of the seat if the spring wire at the top of the seat foam is detached and visible.
5. Replace the door sill cover strip.
6. Replace Bowden cable.

PROCEDURE

Proceed as follows.

1. Interference noise (clattering, rattling) from the 2nd row of seats, between the 40% and 60% rear seat backrest on rough road surfaces:

1. Confirm noise is coming from area indicated.

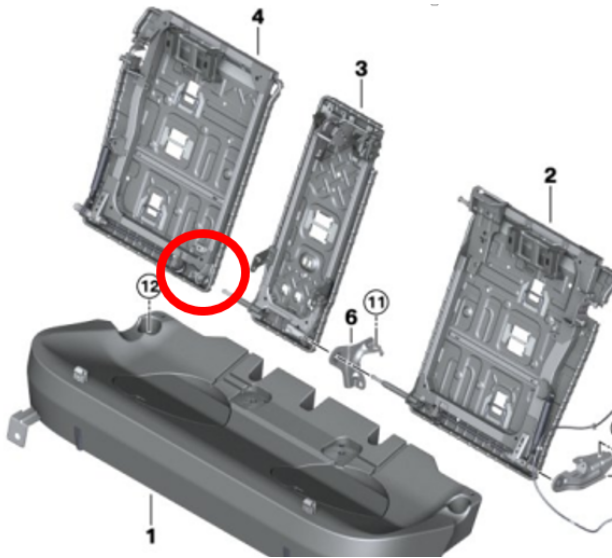

Disassemble 40% passenger seat to access the pivot bushing.

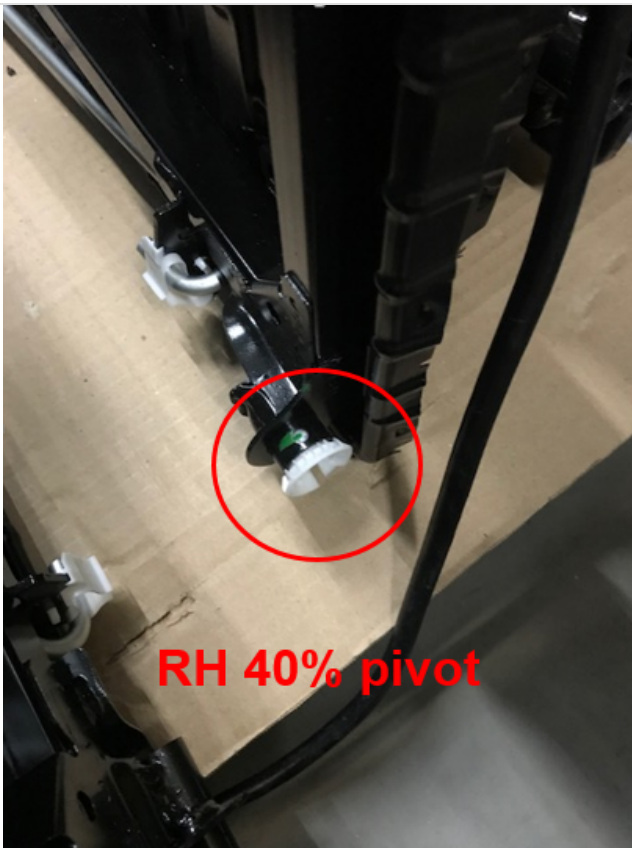

2. Renew the plastic bushing between the 40% and 60% backrest.

This repair part is contained within Service Kit Part Number 52 20 6 994 317.

2. Backrest unlocking function does not work and causes noises:

1. Replace the damaged Bowden cable (9) and make sure that the routing of the Bowden cable is correct.

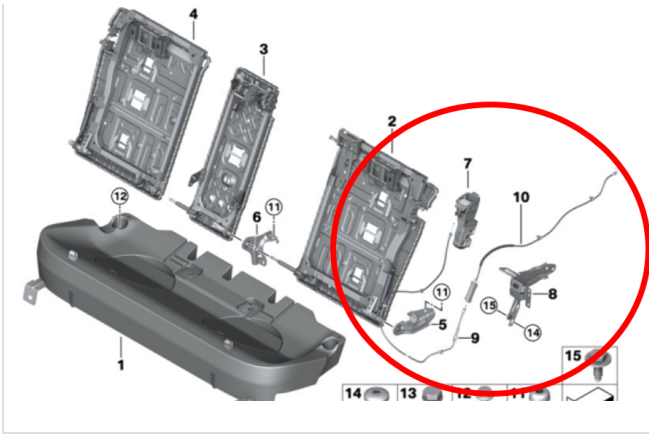

3. Backrest locking (top, bottom) rattles on rough road surfaces without load.

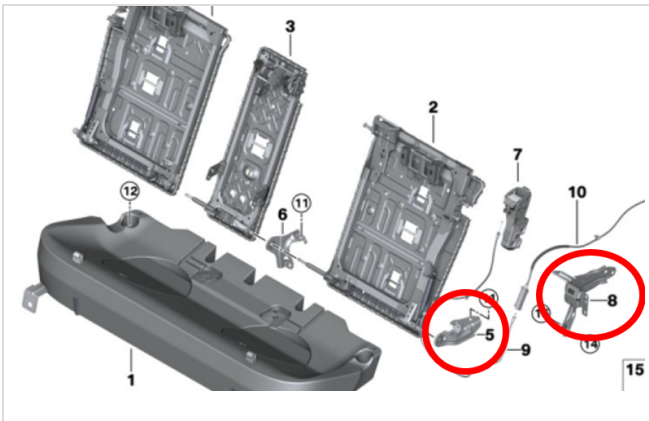

1. If the fault pattern corresponds to the attached video

“V520619NoisefromLatchedbed”

Replace the top and bottom lock of the backrest (5, 8).

4. Squeaking noises from the rear seat bench (left and right) when loaded.

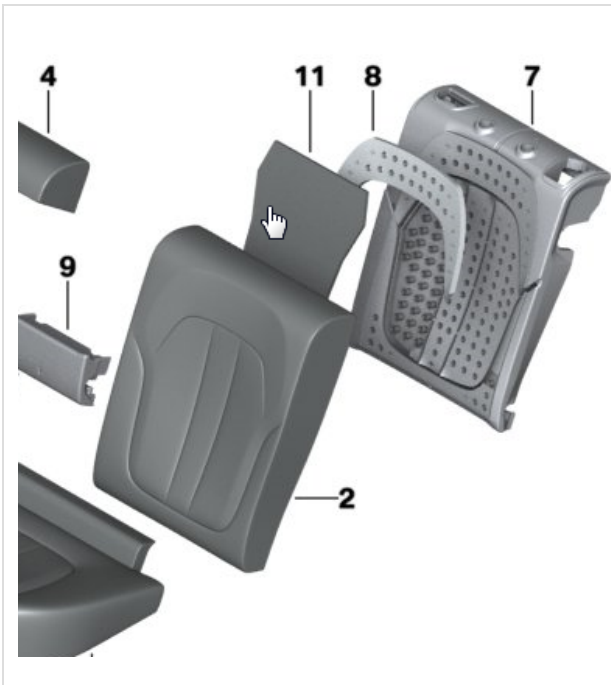

1. Remove the seat cover of the rear seat bench and replace the foam part(s) of the seat if the spring wire at the top of the seat foam is detached and visible (7, 8).

5. Groaning noise when entering and exiting.

1. If the fault pattern corresponds to the attached video-

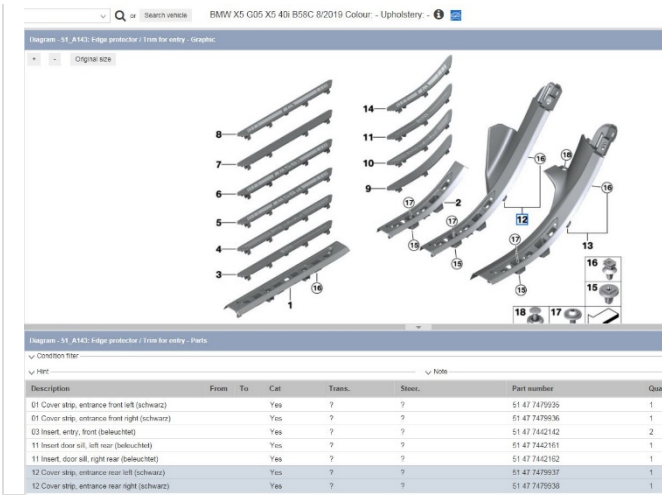

“V520519Noisefromentrysillembed”

Replace the door sill cover strip (12).

6. Unlocking in the luggage compartment, Bowden cable in the luggage compartment does not work and causes interference noises.



1. Renew the Bowden cable in the luggage compartment and ensure that it is routed correctly (10).

PARTS INFORMATION

Obtain and confirm the part numbers for your specific vehicle by entering the chassis number in either ETK or AIR which takes into account specific equipment and/or options.

WARRANTY INFORMATION

This service information bulletin provides technical, diagnostic and repair-related information.

Eligible and Covered Work/Repairs

When used to repair a verified defect in materials or workmanship, the repair procedure information provided in this bulletin is covered under the terms of the BMW New Vehicle Limited Warranty for Passenger Cars and Light Trucks.

When submitting a claim, please follow the established and applicable warranty policy and procedures that apply to the repair being performed (Labor/Part/Sublet – bulk materials).

Supporting Materials

Videos

52 05 19

52 06 19