



Service Bulletin

Bulletin No.: 19-NA-159

Date: August, 2019

INFORMATION

Subject: Information on Elimination of Glove Box Dampener, When Unlatched Glove Box Door Falls Open

Brand:	Model:	Model Year:		Date Breakpoint:		Engine:	Transmission:
		from	to	from	to		
Chevrolet	Colorado	2019	2020	May 7, 2019	EOP	All	All
GMC	Canyon	2019	2020				

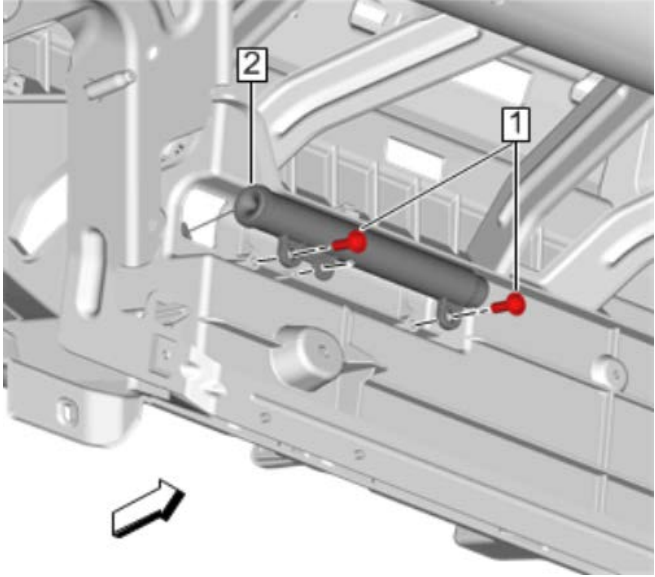
Involved Region or Country	North America, N.A. Export Regions
Additional Options (RPOs)	EXC - LUXURY EDITION, DENALI (Y91)
Condition	Some customers may comment that when unlatching their glove box, the door falls open quicker than they've seen on other same models.
Cause	 <p style="text-align: right;">5374726</p> <p>The cause of the condition is that the Denali models contain a glove box dampener (2) which allows the door to lower at a slower, controlled pace, but this dampener was intentionally removed from all other models. This is NOT a mis-build condition and no repairs are necessary.</p>
Correction	<p>Note: This is NOT a warranty issue and this damper should NOT be installed to vehicles not equipped with it.</p> <p>Please communicate to the customer that the glove box is functioning as designed and this is a normal condition of their vehicle. Please share this information with the customer, including a copy of this message</p>

Version	2
Modified	Released July 16, 2019 Revised August 19, 2019 – Added 2020 Model year and Corrected Breakpoint

GM bulletins are intended for use by professional technicians, NOT a "do-it-yourselfer". They are written to inform these technicians of conditions that may occur on some vehicles, or to provide information that could assist in the proper service of a vehicle. Properly trained technicians have the equipment, tools, safety instructions, and know-how to do a job properly and safely. If a condition is described, **DO NOT** assume that the bulletin applies to your vehicle, or that your vehicle will have that condition. See your GM dealer for information on whether your vehicle may benefit from the information.



WE SUPPORT VOLUNTARY
TECHNICIAN
CERTIFICATION