



Service Bulletin

Bulletin No.: 18-NA-225

Date: August, 2019

TECHNICAL

Subject: No Propulsion – MIL Illuminated with One or More Following DTCs P0ABC, P0AFA, P1AE6, P0D26, P0C78, P0ABB Set

Brand:	Model:	Model Year:		Build Date Breakpoint:		Engine:	Transmission:
		from	to	from	to		
Chevrolet	Bolt EV	2017	2019	—		—	—

Involved Region or Country	North America, South Korea, Middle East
Condition	Some customers may comment on a loss of propulsion with the Malfunction Indicator Lamp (MIL) illuminated.
Cause	<p>The Drive Motor Battery High Voltage Manual Disconnect Lever contains a fuse that may have failed open. The technician may find one or more of the following DTCs set in the Hybrid/EV Powertrain Control Module 2:</p> <ul style="list-style-type: none"> • DTC P0ABC Hybrid/EV Battery Voltage Sensor Circuit Low Voltage • DTC P0AFA Hybrid/EV Battery System Voltage Low Voltage • DTC P1AE6 Battery Energy Control Module Hybrid/EV Battery Voltage Isolation Sensor Circuit • DTC P0C78 Hybrid/EV Battery System Precharge Time Too Long • DTC P0ABB Hybrid/EV Battery Voltage Sensor Performance • DTC P0D26 Battery Charger System Precharge Time Too Long
Correction	Perform the Service Procedure.

Service Procedure

Danger: Always perform the High Voltage Disabling procedure prior to servicing any High Voltage component or connection. Personal Protection Equipment (PPE) and proper procedures must be followed.

The High Voltage Disabling procedure includes the following steps:

- Identify how to disable high voltage.
- Identify how to test for the presence of high voltage.
- Identify condition under which high voltage is always present and personal protection equipment (PPE) and proper procedures must be followed.

Before working on any high voltage system, be sure to wear the following Personal Protection Equipment:

- Safety glasses with appropriate side shields when within 15 meters (50 feet) of the vehicle, either indoors or outdoors.
- Certified and up-to-date Class "0" Insulation gloves rated at 1000V with leather protectors.
 - Visually and functionally inspect the gloves before use.
 - Wear the Insulation gloves with leather protectors at all times when working with the high voltage battery assembly, whether the system is energized or not.

Failure to follow the procedures may result in serious injury or death.

Drive Motor Battery High Voltage Manual Disconnect Lever Replacement

Important: The Drive Motor Battery High Voltage Manual Disconnect Lever is also known as the S15 Manual Service Disconnect (MSD).

1. Place the vehicle in Service Mode.
2. Verify that one or more of the following DTCs are set: DTC P0ABC, P0AFA, P1AE6, P0C78, P0ABB or P0D26. Refer to **Diagnostic System Check - Vehicle** in SI.
 - ⇒ If DTC P0ABC, P0AFA, P1AE6, P0C78, P0ABB or P0D26 are set, Go to Step 3.
 - ⇒ If any other DTCs are set, Go to **Diagnostic Trouble Code (DTC) List - Vehicle** in SI.
3. Vehicle OFF.
4. Disable the high voltage at the A4 Hybrid/EV Battery Pack. Refer to **High Voltage Disabling** in SI.
5. Remove the rear seat cushion. Refer to **Rear Seat Cushion Removal and Installation** in SI.

6. Verify that the S15 Manual Service Disconnect is installed completely, the lever is fully seated and the CPA is secure. Refer to **Drive Motor Battery High Voltage Manual Disconnect Lever Replacement** in SI.

- ⇒ If the S15 Manual Service Disconnect is installed properly, Go to Step 7.
- ⇒ If the S15 Manual Service Disconnect is not installed properly, correct the condition as needed.

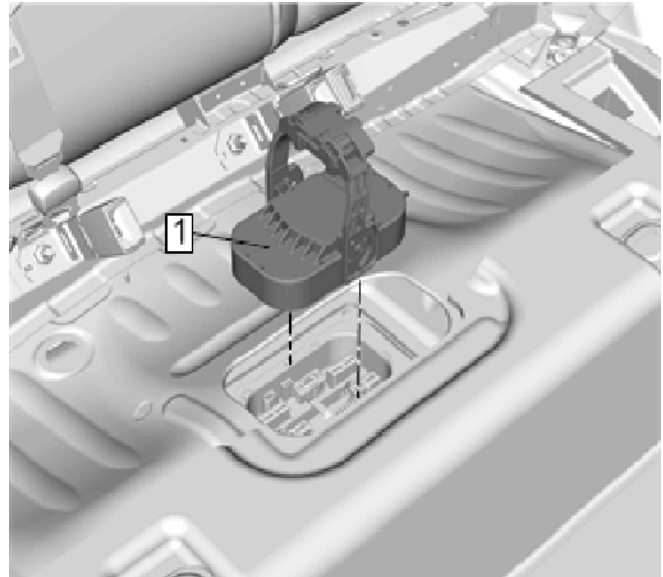

5087054

7. Remove the S15 Manual Service Disconnect (1).

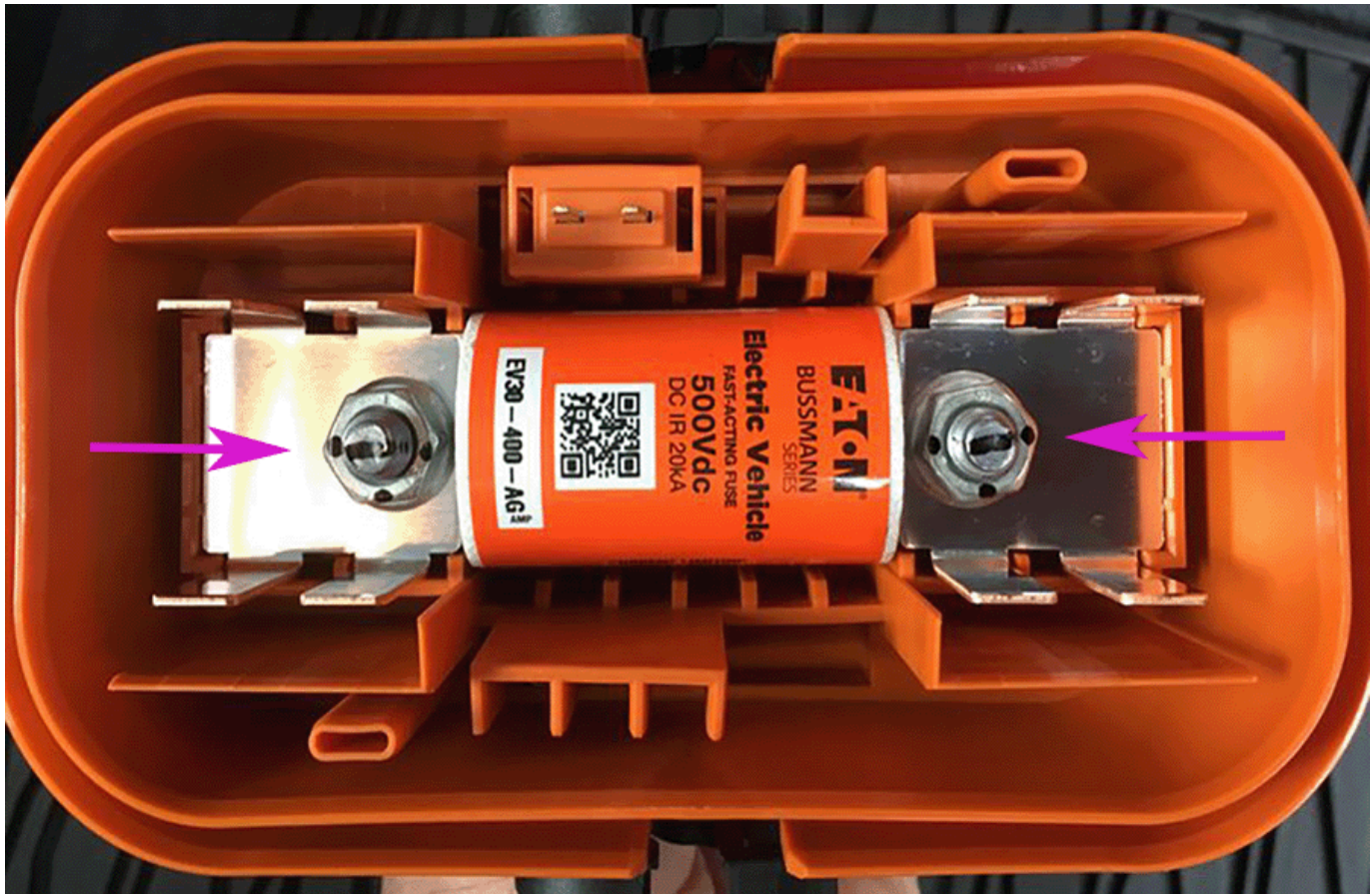

5087244

- 8. Test for less than 10 Ω across the S15 Manual Service Disconnect fuse terminals (the flat blades at each end). Refer to **Testing for Continuity** in SI.
 - ⇒ If the resistance measurement is 10 Ω or greater, replace the S15 Manual Service Disconnect.

9. Install the rear seat cushion.

Notice: Performing the Clear Secured High Voltage DTCs procedure is part of the High Voltage Enabling procedure.

- 10. Enable the high voltage system. Refer to **High Voltage Enabling** in SI.

- 11. Upon completion of the Drive Motor Battery High Voltage Manual Disconnect Lever Replacement, perform the **Diagnostic Repair Verification** in SI.

Warranty Information

For vehicles repaired under warranty, use:

Labor Operation	Description	Labor Time
5030310	Drive Motor Battery High Voltage Manual Disconnect Lever Replacement	Use Published Labor Operation Time

Version Information

Version	2
Modified	Released July 10, 2018 August 08, 2019 – Added all of MY2017 and added MY2018-2019 vehicles and removed the Build Date Breakpoint Information stating: from MY2017 SORP to August 31, 2017.

GM bulletins are intended for use by professional technicians, NOT a "do-it-yourselfer". They are written to inform these technicians of conditions that may occur on some vehicles, or to provide information that could assist in the proper service of a vehicle. Properly trained technicians have the equipment, tools, safety instructions, and know-how to do a job properly and safely. If a condition is described, DO NOT assume that the bulletin applies to your vehicle, or that your vehicle will have that condition. See your GM dealer for information on whether your vehicle may benefit from the information.



WE SUPPORT VOLUNTARY
TECHNICIAN
CERTIFICATION