

Subject		Market
<b>Front Stabilizer Nut Loose</b>		USA
Service Category	Section	
Suspension	Front Suspension	
Applicability		
2019 ES350 (F-Sport)		

**APPLICABLE VEHICLES**

2019	ES350
------	-------

**CONDITION**

Some customers may experience abnormal noise from the front suspension on 2019 ES350 F-Sport models. Noise frequently comes from the left-front of the vehicle while going over bumps.

**RECOMMENDATIONS**

Confirm torque condition of the Front Stabilizer Nut - connecting the Front Stabilizer Link to the Front Stabilizer Bar (LH & RH).

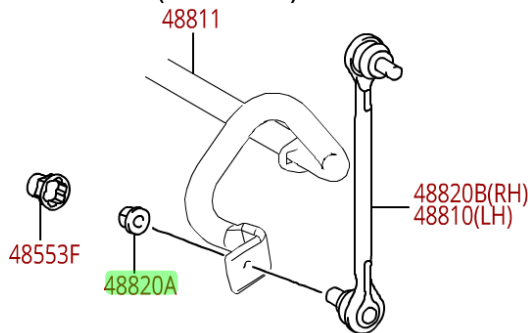

If nut is loose, visually inspect the Front Stabilizer Nut, Link and Bar for damage.



If damage is visible, replace the affected component(s) per Repair Manual. If no damage is visible, tighten Front Stabilizer Nut to torque specification in Repair Manual.

**LINK REFERENCES**

- [FRONT SUSPENSION: FRONT STABILIZER BAR: COMPONENTS; 2019 - 2020 MY ES300H ES350 \[06/2018 - ???????\]](#)