



TECHNICAL BULLETIN

18 JUN 2019

© Jaguar Land Rover North America, LLC

NOTE: The information in Technical Bulletins is intended for use by trained, professional Technicians with the knowledge, tools, and equipment required to do the job properly and safely. It informs these Technicians of conditions that may occur on some vehicles, or provides information that could assist in proper vehicle service. The procedures should not be performed by 'do-it-yourselfers'. If you are not a Retailer, do not assume that a condition described affects your vehicle. Contact an authorized Land Rover service facility to determine whether this bulletin applies to a specific vehicle.

INFORMATION

SECTION:

308-00

SUBJECT /CONCERN:

8HP70 Automatic Transmission Casing Oil Leak

AFFECTED VEHICLE RANGE:

MODEL:	MODEL YEAR:	VIN:	ASSEMBLY PLANT:	APPLICABILITY:
Discovery 4 / LR4 (LA)	2015-2016	731301-812783	Solihull	TDV6 3.0L Diesel /V6 S/C 3.0L Petrol , Vehicles With: 8HP70 8-Speed Automatic Transmission AWD
Range Rover (LG)	2015-2016	197043-279179	Solihull	TDV6 3.0L Diesel /TDV8 4.4L Diesel/V8 S/C 5.0L Petrol, Vehicles With: 8HP70 8-Speed Automatic Transmission AWD

MODEL:	MODEL YEAR:	VIN:	ASSEMBLY PLANT:	APPLICABILITY:
Range Rover Sport (LW)	2015-2016	504511-577765	Solihull	GTDi 2.0L Petrol/TDV6 3.0L Diesel /TDV8 4.4L Diesel/V8 S/C 5.0L Petrol, Vehicles With: 8HP70 8-Speed Automatic Transmission AWD
Range Rover Sport (LW)	2015-2016	601763-648338	Solihull	TDV6 3.0L Diesel /V8 S/C 5.0L Petrol, Vehicles With: 8HP70 8-Speed Automatic Transmission AWD

MARKETS:

NORTH AMERICA

CONDITION SUMMARY:

SITUATION:

Oil leak from underneath the vehicle.

CAUSE:

This may be caused by internal porosity in the automatic transmission, allowing oil to leak between the automatic transmission and the transfer case.

ACTION:

Follow the instructions below.

PARTS:

PART NUMBER	DESCRIPTION	QUANTITY
LR133314	Automatic transmission insert	1
TYG500130	Bolt(s) - Driveshaft flange	4
TYG500141	Bolt(s) - Driveshaft flange	6
TYP500180	Bolt(s) - Driveshaft flange - Discovery 4	6
WYP000025	Bolt(s) - Exhaust - Discovery 4 TDV6 3.0L Diesel	5

PART NUMBER	DESCRIPTION	QUANTITY
LR016619	Exhaust gasket - Discovery 4 TDV6 3.0L Diesel	1
LR016621	Exhaust gasket - Discovery 4 TDV6 3.0L Diesel	1
IYX500050	Transfer case O-ring	1
LR086041	Seal(s) - Single speed transfer case	1
IZB500030	Seal(s) - Twin speed transfer case	1
LR048842	Washer(s) - Single speed transfer case	2
IYF500030	Washer(s) - Twin speed transfer case	2
LR125418	Devcon putty	1
LR048849	Transmission oil - Single speed transfer case	2
IYK500010	Transmission oil - Twin speed transfer case	2

WARRANTY:

NOTES:

- Repair procedures are under constant review, and therefore times are subject to change; those quoted here must be taken as guidance only. Use TOPIx to obtain the latest repair time.
- The JLR claims submission system requires the use of causal part numbers. Labor only claims must show the causal part number with a quantity of zero.

Discovery 4

DESCRIPTION	SRO	TIME (HOURS)	CONDITION CODE	CAUSAL PART
Automatic transmission insert - TDV6 3.0L diesel - Twin Speed transfer case - Without particulate filter - Install	44.20.89.01	9.1	D1	LR071402
Automatic transmission insert - TDV6 3.0L diesel - Twin Speed transfer case - With particulate filter - Install	44.20.89.01	9.8	D1	LR071402

DESCRIPTION	SRO	TIME (HOURS)	CONDITION CODE	CAUSAL PART
Automatic transmission insert - TDV6 3.0L diesel - Single Speed transfer case - Without particulate filter - Install	44.20.89.01	9	D1	LR071402
Automatic transmission insert - TDV6 3.0L diesel - Twin Speed transfer case - With particulate filter - Install	44.20.89.01	9.6	D1	LR071402
Automatic transmission insert - TDV6 3.0L diesel - Twin Speed transfer case - With particulate filter - With Diesel Exhaust Fluid (DEF) - Install	44.20.89.01	10.8	D1	LR071402
Automatic transmission insert - TDV6 3.0L diesel - Single Speed transfer case - With particulate filter - With DEF - Install	44.20.89.01	10.6	D1	LR071402
Automatic transmission insert - V6 S/C 3.0L petrol - Single Speed transfer case - Install	44.20.89.01	8.9	D1	LR071402
Automatic transmission insert - V6 S/C 3.0L petrol - Twin Speed transfer case - Install	44.20.89.01	9.2	D1	LR071402

Range Rover

DESCRIPTION	SRO	TIME (HOURS)	CONDITION CODE	CAUSAL PART
Automatic transmission insert - TDV6 3.0L diesel - With particulate filter - Up to 16 Model Year (MY) - Install	44.20.89.01	9	D1	LR071402
Automatic transmission insert - TDV6 3.0L diesel - Without particulate filter - Install	44.20.89.01	9	D1	LR071402
Automatic transmission insert - TDV6 3.0L diesel - With particulate filter - With Diesel Exhaust Fluid (DEF) - 16 MY - Install	44.20.89.01	9	D1	LR071402
Automatic transmission insert - TDV6 3.0L diesel - With particulate filter - Without DEF - 16 MY - Install	44.20.89.01	9	D1	LR071402
Automatic transmission insert - TDV8 4.4L diesel - With particulate filter - Up to 16 MY - Install	44.20.89.01	10.1	D1	LR071402
Automatic transmission insert - TDV8 4.4L diesel - Without particulate filter - Install	44.20.89.01	10.1	D1	LR071402

DESCRIPTION	SRO	TIME (HOURS)	CONDITION CODE	CAUSAL PART
Automatic transmission insert - TDV8 4.4L diesel - Without particulate filter - With DEF - 16 MY - Install	44.20.89.01	8.8	D1	LR071402
Automatic transmission insert - TDV8 4.4L diesel - Without particulate filter - Without DEF - 16 MY - Install	44.20.89.01	8.8	D1	LR071402
Automatic transmission insert - V8 5.0L S/C petrol - Install	44.20.89.01	9.6	D1	LR071402

Range Rover Sport

DESCRIPTION	SRO	TIME (HOURS)	CONDITION CODE	CAUSAL PART
Automatic transmission insert - TDV6 3.0L diesel - Twin Speed transfer case - Without particulate filter - Install	44.20.89.01	9.6	D1	LR071402
Automatic transmission insert - TDV6 3.0L diesel - Single Speed transfer case - Without particulate filter - Install	44.20.89.01	9.6	D1	LR071402
Automatic transmission insert - V8 5.0L S/C petrol - Install	44.20.89.01	9.7	D1	LR071402
Automatic transmission insert - GTDi 2.0L petrol - Install	44.20.89.01	9.9	D1	LR071402
Automatic transmission insert - TDV6 3.0L diesel - Twin Speed transfer case - With particulate filter - Up to 16 MY - Install	44.20.89.01	9.6	D1	LR071402
Automatic transmission insert - TDV6 3.0L diesel - Single Speed transfer case - With particulate filter - Up to 16 MY - Install	44.20.89.01	9.6	D1	LR071402
Automatic transmission insert - TDV6 3.0L diesel - Single Speed transfer case - With particulate filter - With DEF - 16 MY - Install	44.20.89.01	9	D1	LR071402
Automatic transmission insert - TDV6 3.0L diesel - Single Speed transfer case - With particulate filter - Without DEF - 16 MY - Install	44.20.89.01	9	D1	LR071402
Automatic transmission insert - TDV6 3.0L diesel - Twin Speed transfer case - With particulate filter - With DEF - 16 MY - Install	44.20.89.01	9	D1	LR071402

DESCRIPTION	SRO	TIME (HOURS)	CONDITION CODE	CAUSAL PART
Automatic transmission insert - TDV6 3.0L diesel - Twin Speed transfer case - With particulate filter - Without DEF - 16 MY - Install	44.20.89.01	9	D1	LR071402
Automatic transmission insert - TDV8 4.4L diesel - Twin Speed transfer case - With particulate filter - Up to 16 MY - Install	44.20.89.01	10.1	D1	LR071402
Automatic transmission insert - TDV8 4.4L diesel - Twin Speed transfer case - Without particulate filter - Install	44.20.89.01	10.1	D1	LR071402
Automatic transmission insert - TDV8 4.4L diesel - Twin Speed transfer case - With particulate filter - With DEF - 16 MY - Install	44.20.89.01	8.9	D1	LR071402
Automatic transmission insert - TDV8 4.4L diesel - Twin Speed transfer case - With particulate filter - Without DEF - 16 MY - Install	44.20.89.01	8.9	D1	LR071402

 **NOTE:**

Normal Warranty procedures apply.

SERVICE INSTRUCTION:

Diagnosis

1. Confirm the source of the oil leak using the TOPIx Workshop Manual (see TOPIx Workshop Manual section 307-01: Diagnosis and Testing - 8HP70 8 - Speed Automatic Transmission AWD - 8 - Speed Transmission issues - Oil Leak Detection).
 - If the source of the oil leak has now been repaired, **do not continue with this bulletin.**
 - If the source of the oil leak has not been repaired, **continue to 'Transmission Oil Leak Repair'.**

Transmission Oil Leak Repair

WARNING:

Safety goggles, protective gloves and a mask must be worn when using Devcon putty.

1. Remove the transfer case (see TOPlx Workshop Manual section 308-07: Manual Transmission/Transaxle, Clutch and Transfer Case -- Removal -- Transfer Case).

NOTE:

Make sure the Devcon putty does not come into contact with the transmission output shaft.

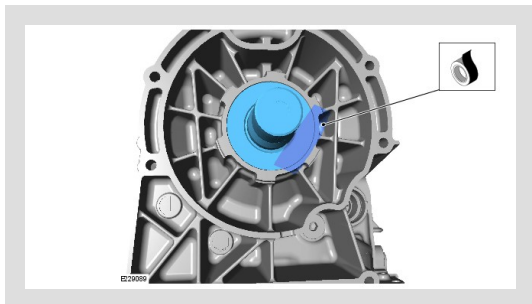

Apply suitable protective tape to the highlighted area of the transmission.

3.

NOTE:

To assist in completing the repair, watch the video as an example before continuing with steps 4 - 6 (the video shows the 8HP45 transmission).

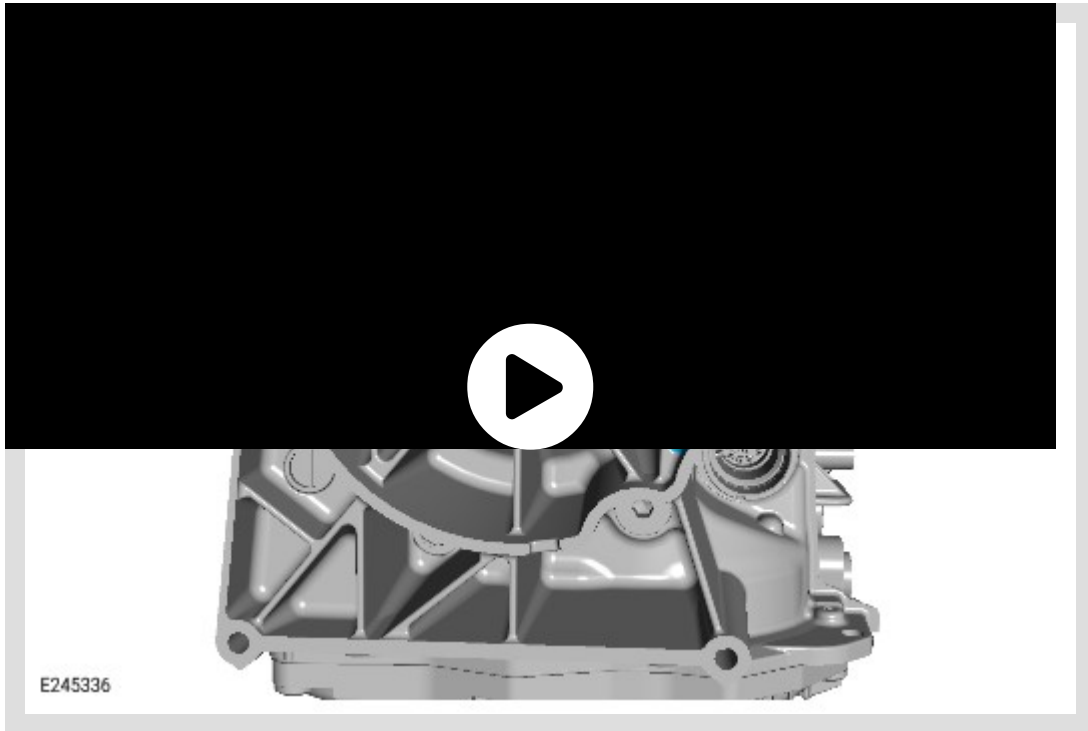

Use a suitable solvent-based cleaning fluid to thoroughly clean the highlighted area of the transmission.

4.

⚠ CAUTION:

The highlighted area of the transmission must be free of all oil and contamination before proceeding.

⚠ NOTES:

- Devcon putty mix ratio: 4 parts resin / 1 part hardener. Refer to the manufacturer's instructions for more information.
- Make sure that the highlighted area of the transmission is fully covered by a layer of Devcon putty.

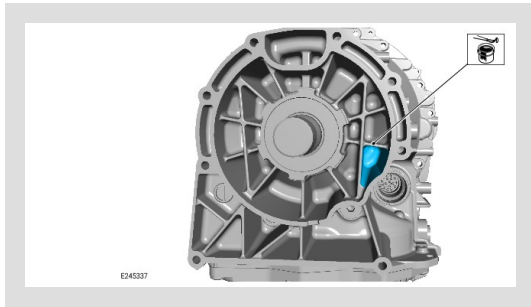

Apply an even layer of Devcon putty to the highlighted area of the transmission.

5.

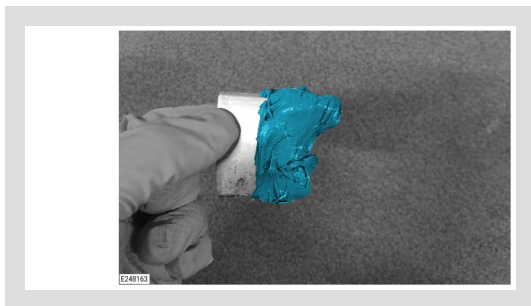

Use a suitable tool apply a layer of Devcon to the transmission insert.

6.

⚠ CAUTION:

Make sure that all machined faces are free of any contamination, Devcon, etc. If Devcon contacts the machined faces, it must be cleaned/removed immediately.

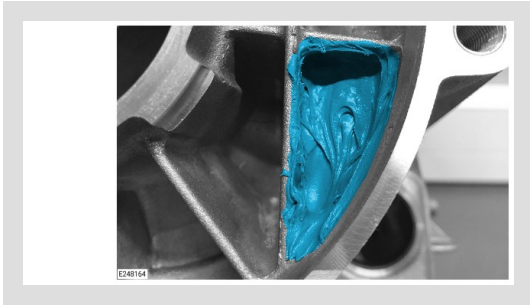

Using a suitable tool install the transmission insert into the area shown and apply an even layer of Devcon putty to the transmission insert until it is completely filled and covered.

7.

Allow the Devcon putty to completely cure:

- The transfer case must be left for at least 8 hours before installation.
- The ambient air temperature must remain above 24°C for the initial 45 minutes.
- The ambient air temperature must remain above 16°C for the remaining 7 hours, 15 minutes.
- Refer to the manufacturer's instructions for more information.

8.

⚠ NOTE:

Do not install the transmission undershield until the transmission oil level is checked in step 9.

Install the transfer case (see TOPlx Workshop Manual section 308-07: Manual Transmission/Transaxle, Clutch and Transfer Case -- Installation -- Transfer Case).

9.

Check the transmission fluid level (see TOPlx Workshop Manual section 307-01 - General Procedures - Transmission Fluid Level Check).