



**IMPORTANT SERVICE  
INFORMATION FOR:**

- ✓ SERVICE MANAGER
- ✓ SERVICE ADVISOR
- ✓ TECHNICIAN
- ✓ PARTS DEPARTMENT
- ✓ WARRANTY PERSONNEL

BULLETIN NUMBER:  
**SB19-L-002**

ISSUE DATE:  
**JULY 2019**

GROUP:  
**FUEL AND EXHAUST**

## HEATED FUEL SEDIMENTER ASSEMBLY INSTALLATION

### AFFECTED VEHICLES

- 2011 MY – 2017 MY Isuzu N-Series  
Equipped with 5.2L 4HK1 Engines

### INFORMATION

Isuzu Commercial Truck of America is pleased to announce the availability of a front frame mounted heated fuel sedimenter kit for 2011 MY – 2017 MY N-Series trucks equipped with a 5.2L 4HK1 diesel engine. Installing these kits can help minimize the chances of fuel filters becoming clogged due to gelling in cold weather conditions. The kit part number, ordering information, and installation instructions are in this bulletin. These kits are not designed for use on 2018 model year and newer Isuzu trucks.

**NOTE: Be sure to perform regular fuel filter maintenance per the Owner's Manual.**

### MAINTENANCE INTERVAL

Description	Fuel Filter Maintenance Interval	
	Miles (Km)	Time
Main Fuel Filter	15,000 (24,000)	Or every 12 months
Secondary Fuel Filter	15,000 (24,000)	Or every 12 months

### PARTS INFORMATION

The following fuel sedimenter kits are available from AIPDN.

Model Year	Part Number	Description	Quantity
16MY – 17MY	2-90KIT-001-0	16/17MY HEATED FUEL SEDIMENTER KIT	1
11MY – 15MY	2-90KIT-002-0	14/15MY HEATED FUEL SEDIMENTER KIT	1
11MY – 13MY	2-90KIT-003-0	CLEAR BOWL TO SEDIMENTER TO METAL KIT	*

\*For 11 MY – 13 MY, This kit will be required to complete installation only if bulletin SB14-L-001 has not been completed. If the fuel sedimenter has a clear bowl then, bulletin SB14-L-001 has not been performed.

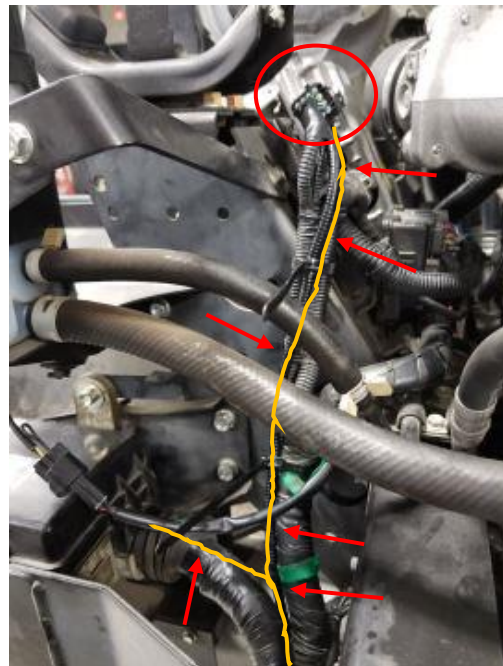
## SERVICE PROCEDURE

### Installation

1. Place the vehicle in park, apply the parking brake, and remove the key from the Engine Control Switch.
2. Disconnect the negative battery cable.
3. Lay extension harness on the floor, under the driver's side frame as shown in Figure 1.
4. Route the white/blue wire and relay wires from the extension harness along the front chassis harness. Direct the white/blue wire up to the H-52 connector and the relay wires over to the relay box. (See Figure 2.)



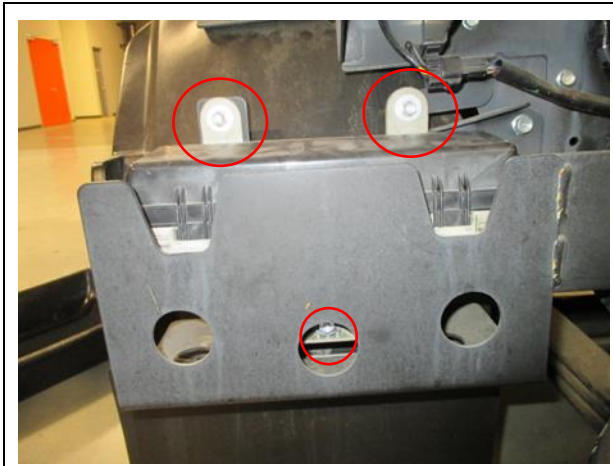
**Figure 1** – Extension harness under driver's side frame.



**Figure 2** – Routing for White/Blue wire to H-52 connector and relay box.

5. Remove the three (3) 12mm fuse box mounting bolts shown in Figure 3 and set these aside for later use.
6. Disassemble the fuse box by using a flat blade screwdriver to release the locking tabs holding the lower cover to the bottom of the fuse block. Set lower cover to the side for later use.

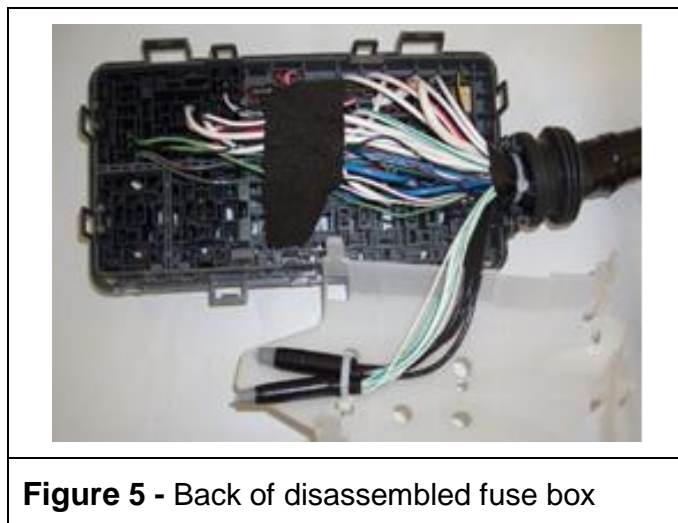
7. Continue removing the inner cover by removing PVC tape, pulling the grommet off the end of the fuse box halves (see Figure 4) and using the same process to release the locking tabs as in Step 6. Move cover to the side as shown in Figure 5.



**Figure 3 - Mounting bolts**



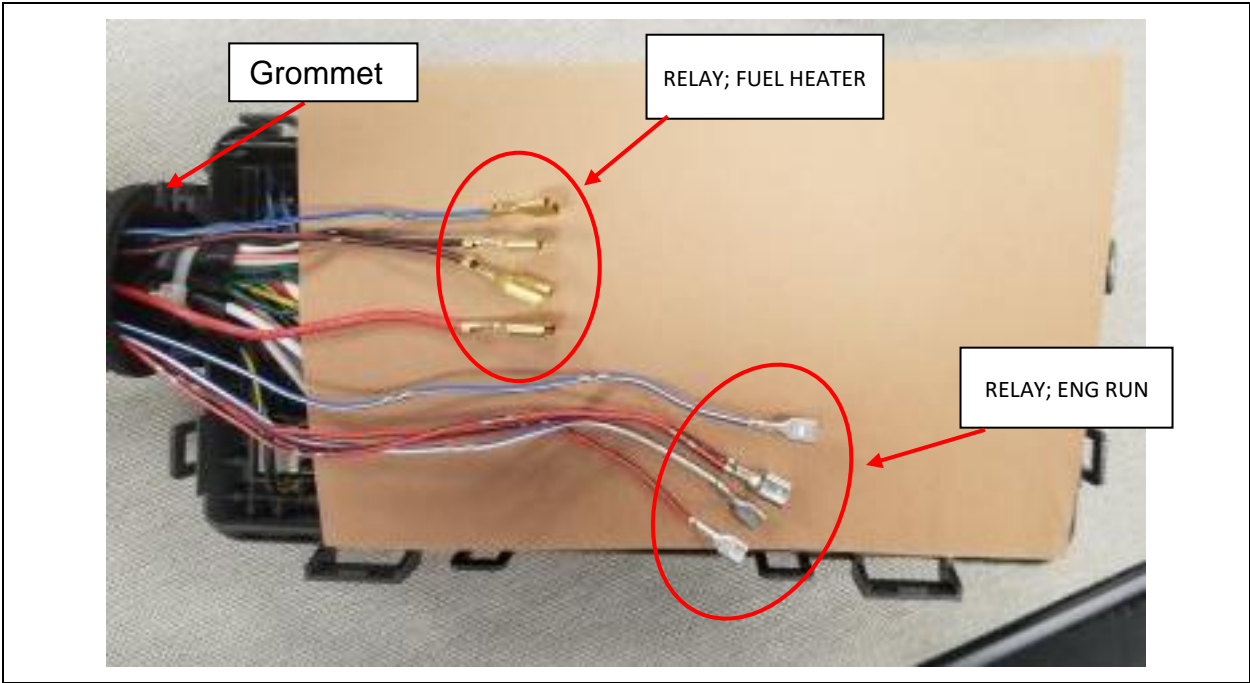
**Figure 4**



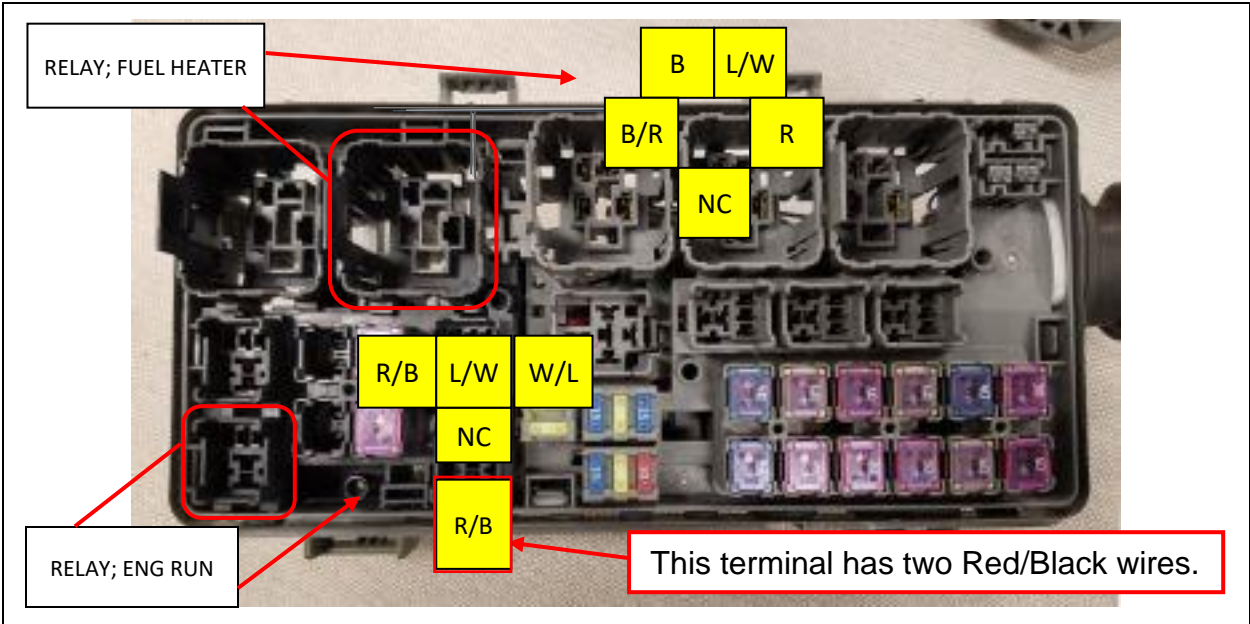
**Figure 5 - Back of disassembled fuse box**

8. Feed the female spade terminals from the extension harness through rubber grommet and into fuse box. (See Figure 6.) On Model Years 2011 to 2015 route the extension harness's eight wires to the Engine Run Relay and Fuel Heater Relay locations as shown in Figures 6 and 7. Model years 2016 and 2017 have only four extension harness wires that route to the Fuel Heater Relay location as shown in Figure 8 and 9. Ensure that the proper size terminals are installed into the proper locations to ensure the correct fit and to avoid terminal and connector damage.

**CAUTION: Insertion of female spade terminals into the wrong locations may cause damage to connector, terminals, and electrical system.**

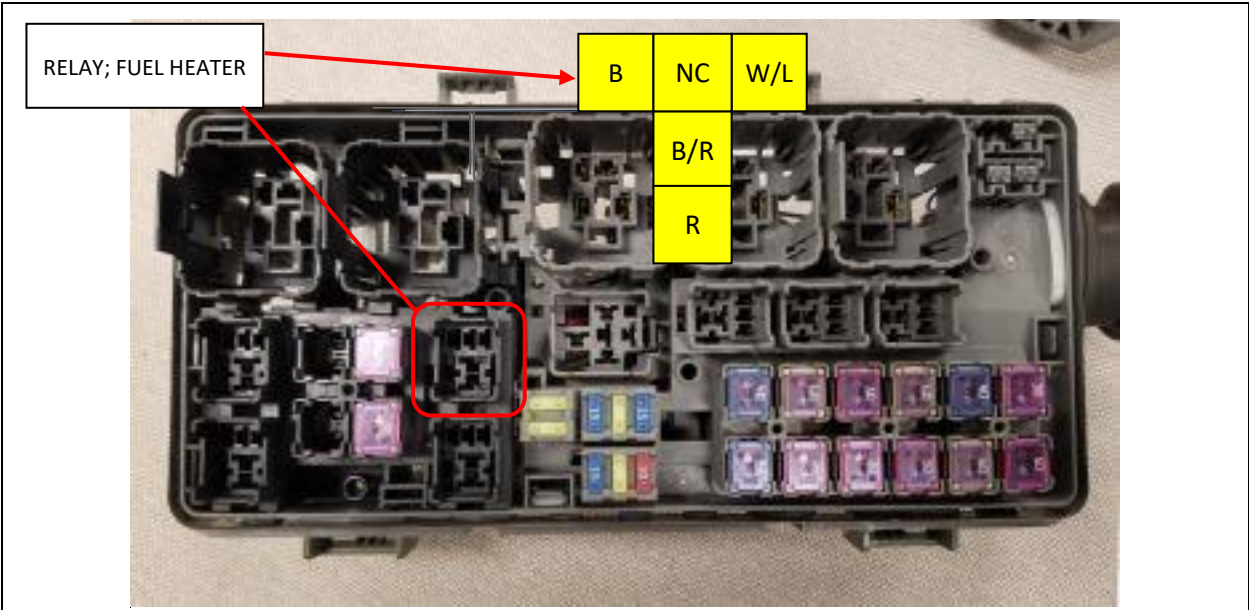


**Figure 6** 2011 – 2015 MY harness shown.



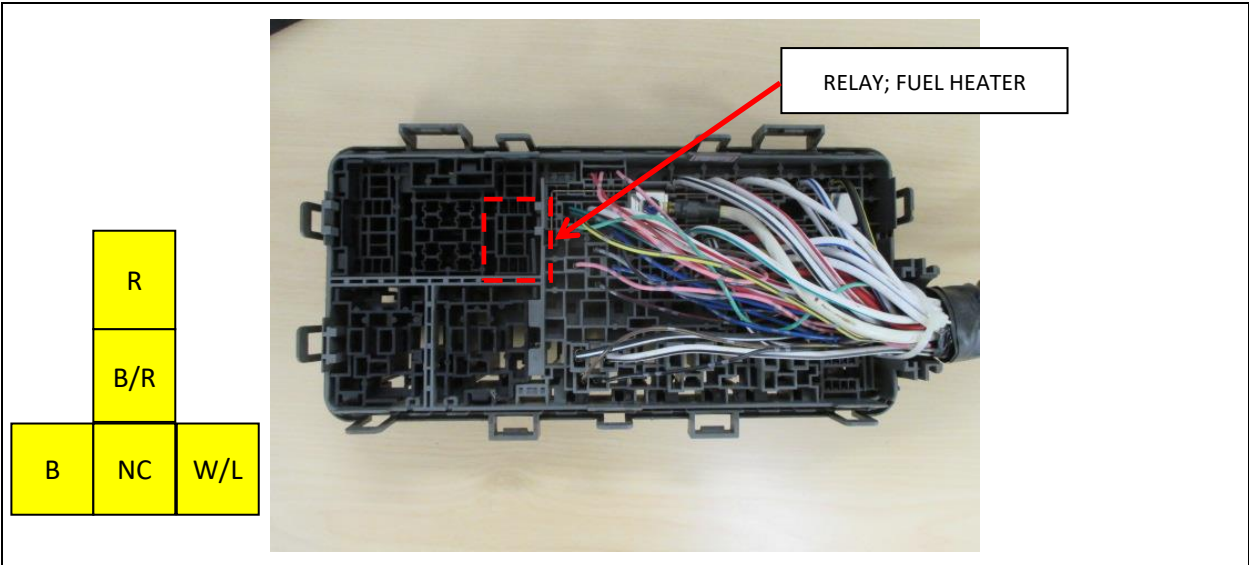
**Figure 7 - Top view:** Model Years 2011 to 2015

**Wire Colors:** W - White R - Red B – Black L - Blue



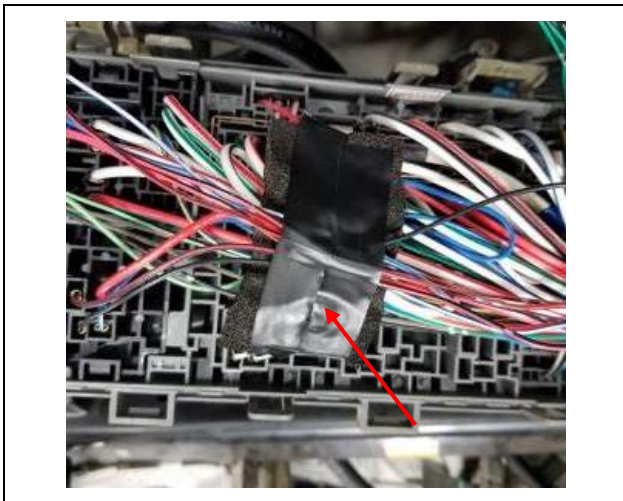
**Figure 8** - Top view: Model Years 2016 and 2017

**Wire Colors:** W - White R - Red B – Black L - Blue



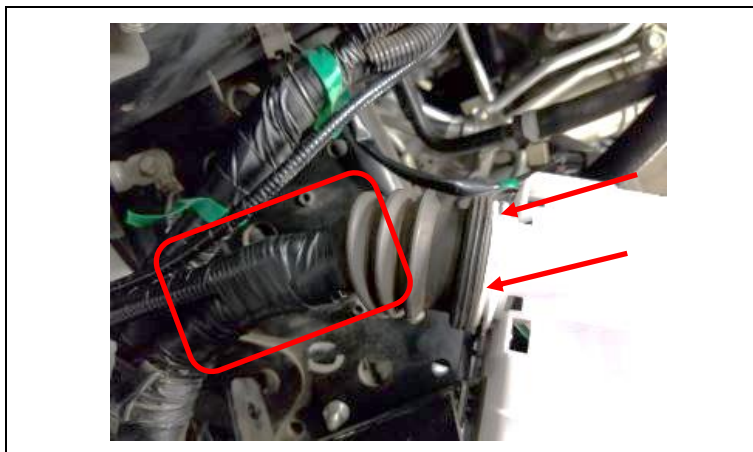
**Figure 9** - Bottom view: Model Years 2016 and 2017

- Use the mastic tape (provided with the Kit) to secure the added wiring as shown in Figure 10.



**Figure 10** – Red arrow shows tape holding extension harness wires.

10. Install inner cover onto fuse box, secure the rubber grommet over the lower cover and fuse box. Use electrical tape to insulate the added extension harness wiring. (See Figure 11.)

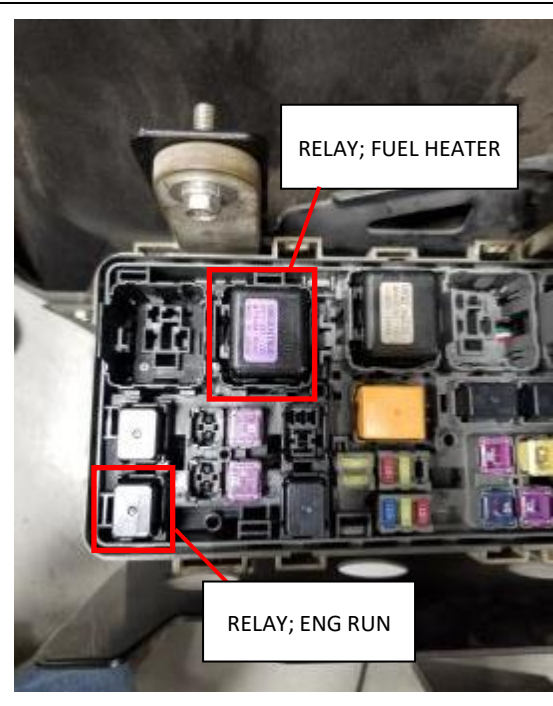


**Figure 11** – Tape on extension harness behind grommet

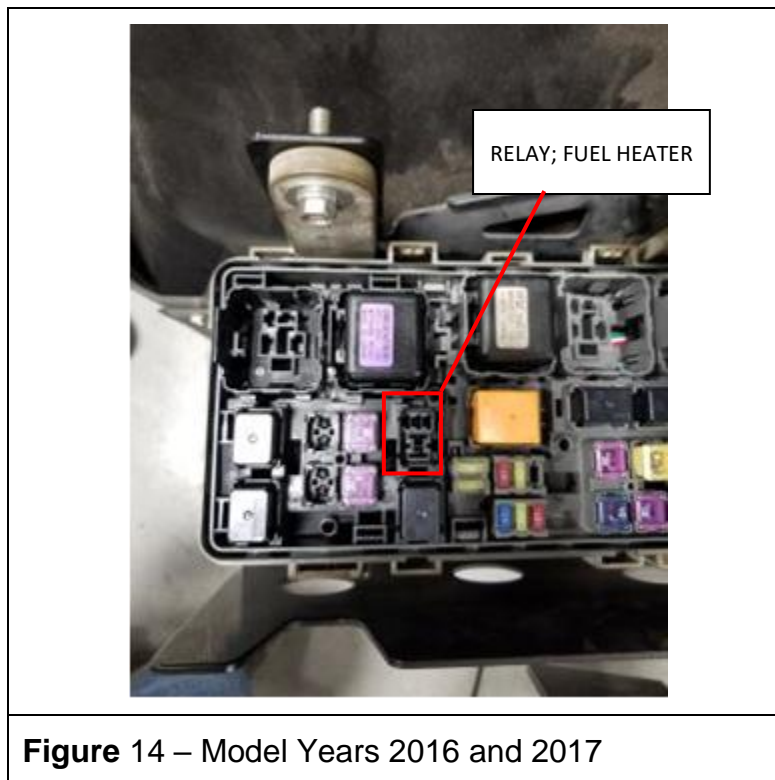
11. Install lower cover.
12. Re-install the fuse box using the three (3) fuse box mounting bolts set aside earlier and torque to 15 N•m (11lb•ft). Apply tie strap to secure to the fuse box to the front frame harness. (See Figure 12.)
13. On Model Years 2011 to 2015 install the Engine Run Relay and the Fuel Heater Relay in the locations specified as shown in Figure 13. On Model Years 2016 and 2017, install the Fuel Heater Relay as shown in Figure 14.
14. Install the fuse box cover by snapping the locking tabs into place.



**Figure 12 - Tie strap location**

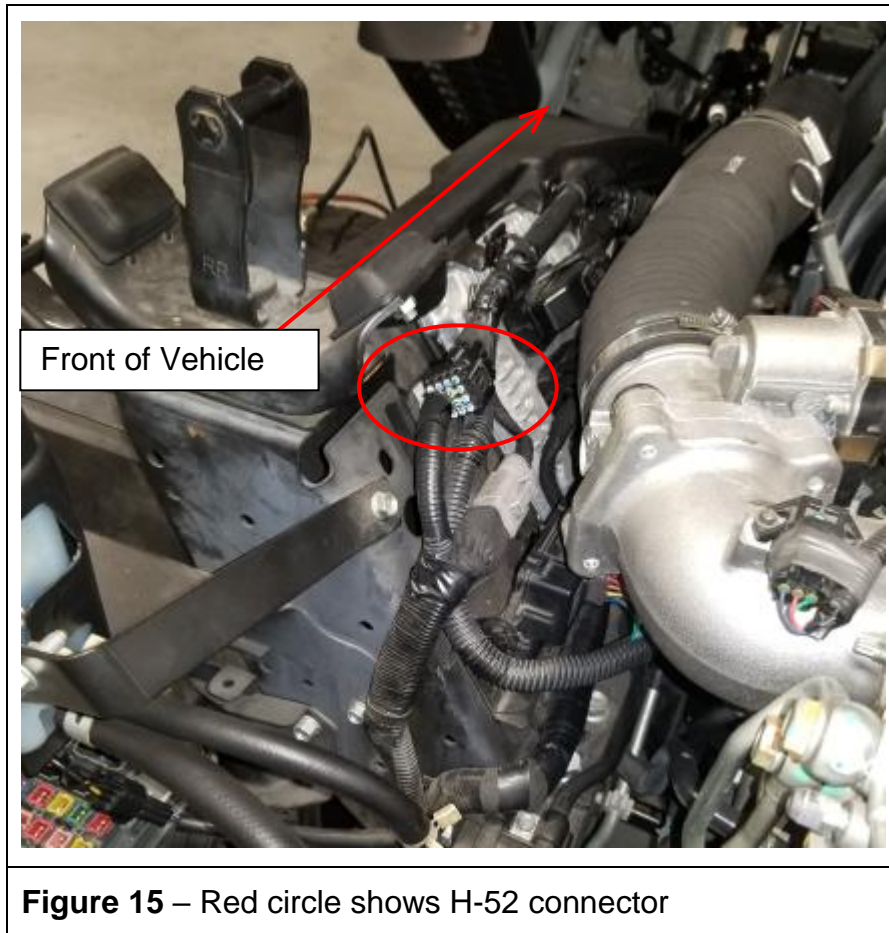


**Figure 13 – Model Years 2011 to 2015**

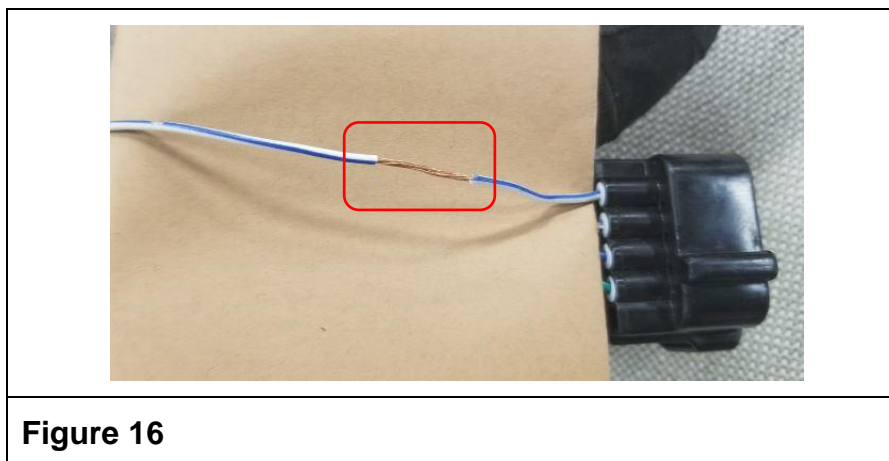


**Figure 14 – Model Years 2016 and 2017**

15. Locate black H-52 connector as shown in Figure 15.



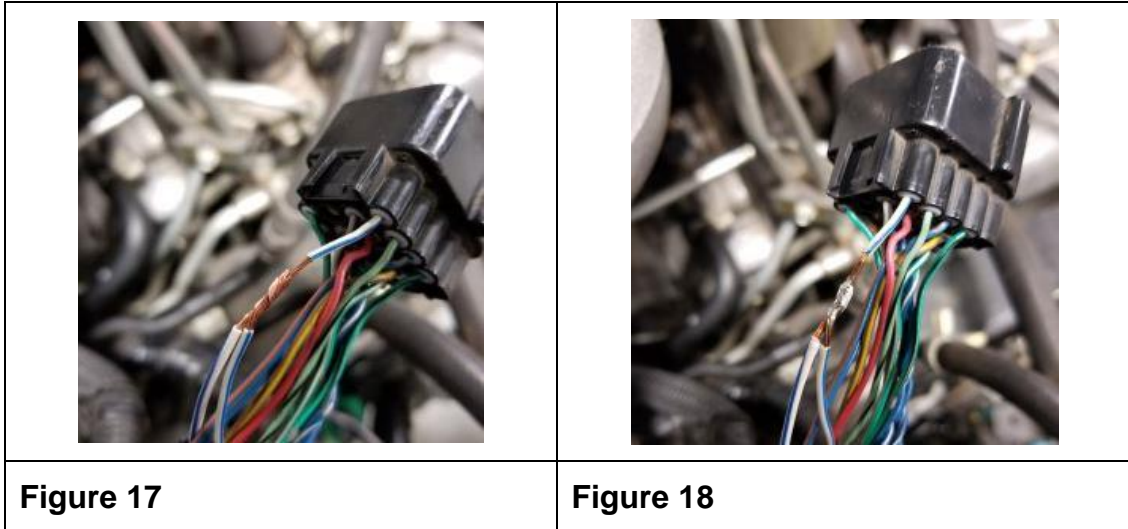
16. Disconnect the H-52 connector. On the front frame side of the harness, remove 60 mm of electrical tape from the back of the connector. Pull back the protective cover exposing the white/blue wire going to pin 16.
17. Using wire strippers, remove 15mm of insulation from the white/blue wire in the front frame harness starting 30mm from the back of the H-52 connector, as shown in Figure 16.



**IMPORTANT:** Be careful not cut the white/blue wire in half while removing the insulation.

18. Use wire strippers to remove 15mm of insulation from the end of the white/blue wire on the extension harness and attach to white/blue wire from the front frame harness in Step 17, as shown in Figure 17.

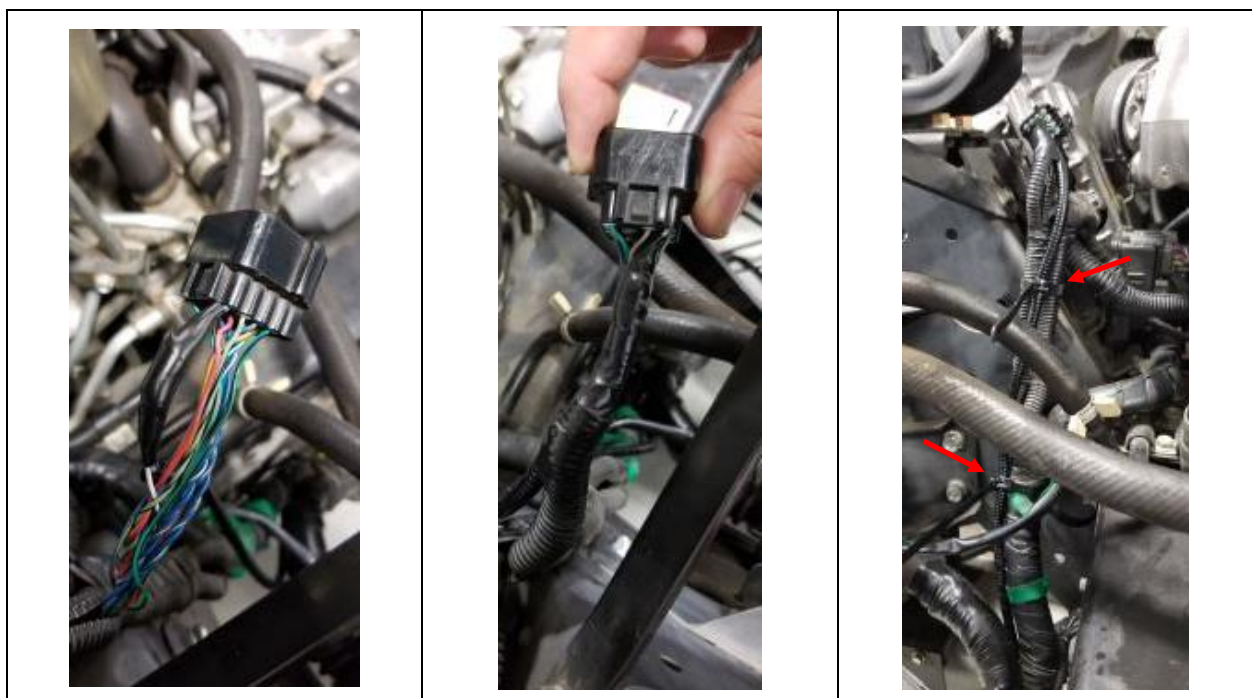
19. Use a soldering iron and solder the two wires together as shown in Figure 18.



20. Use the supplied mastic tape to wrap and insulate the exposed wiring as shown in Figure 19 and then cover with vinyl electrical tape.

21. Re-secure the wiring into the wire loom protective cover. (See Figure 20.)

- Use electrical tape to wrap harness at the ends of the wiring loom protective cover rests on the electrical harness.
- Secure the wires into the loom ensuring that all exposed wiring is covered.
- Wrap the wiring loom protective cover with vinyl electrical tape.
- Apply tie straps to secure to front frame harness as shown in Figure 21.

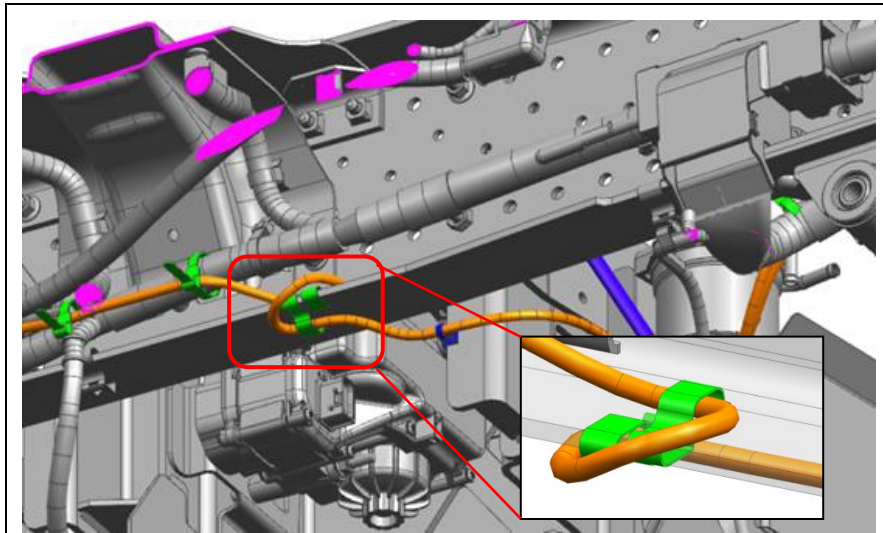


**Figure 19**

**Figure 20**

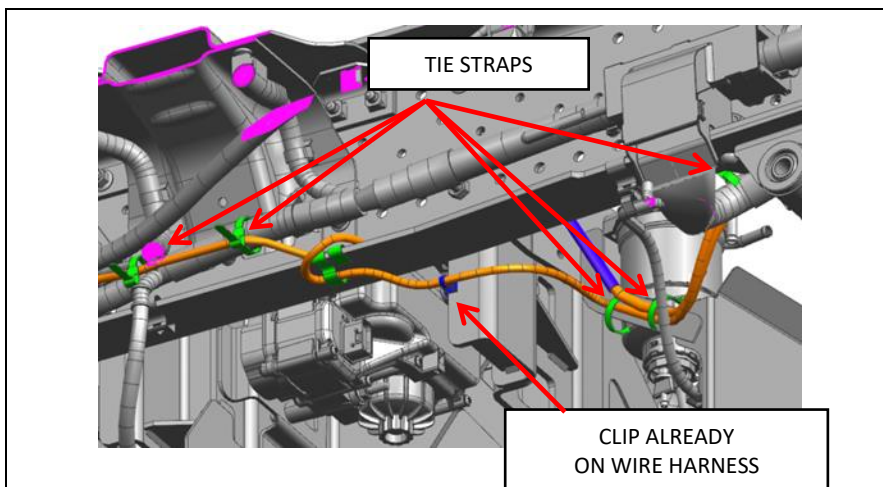
**Figure 21 - Tie strap locations**

22. Route extension harness behind sedimenter bracket and apply a clip to secure harness to the bottom of frame. (Route the harness so that it starts underneath the frame then faces to the inner side of the frame as shown in Figure 22.)



**Figure 22**

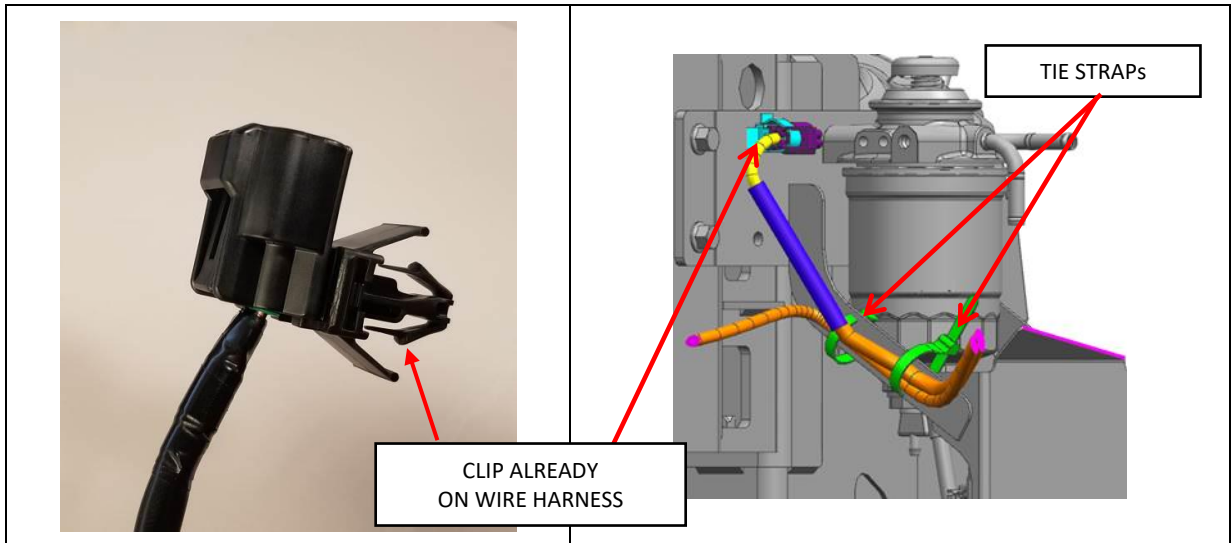
23. Attach the extension harness to the front frame harness using tie straps as shown in Figure 23.



**Figure 23 - Tie strap locations**

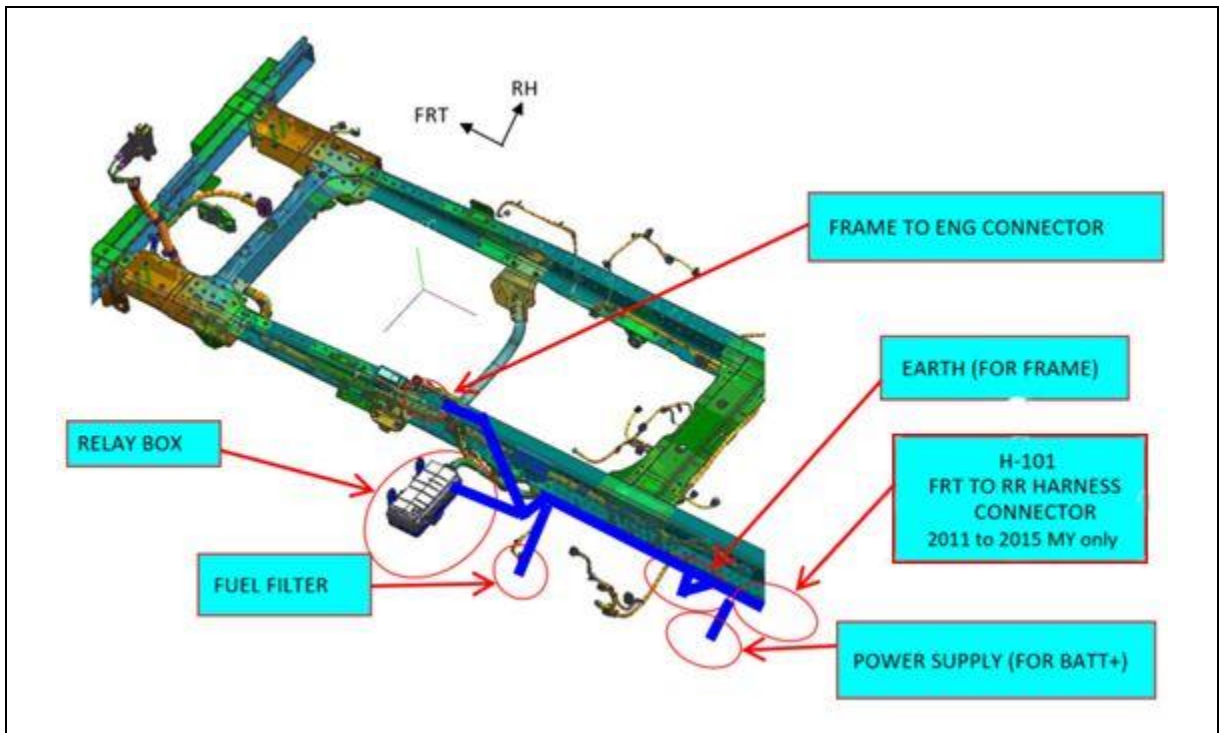
24. Route the heated fuel sedimenter 2 pin black connector from extension harness towards fuel sedimenter and attach to sedimenter bracket using the connector

supplied on the harness. Apply tie straps to hold extension harness to fuel sedimenter bracket. (See Figure 24.)



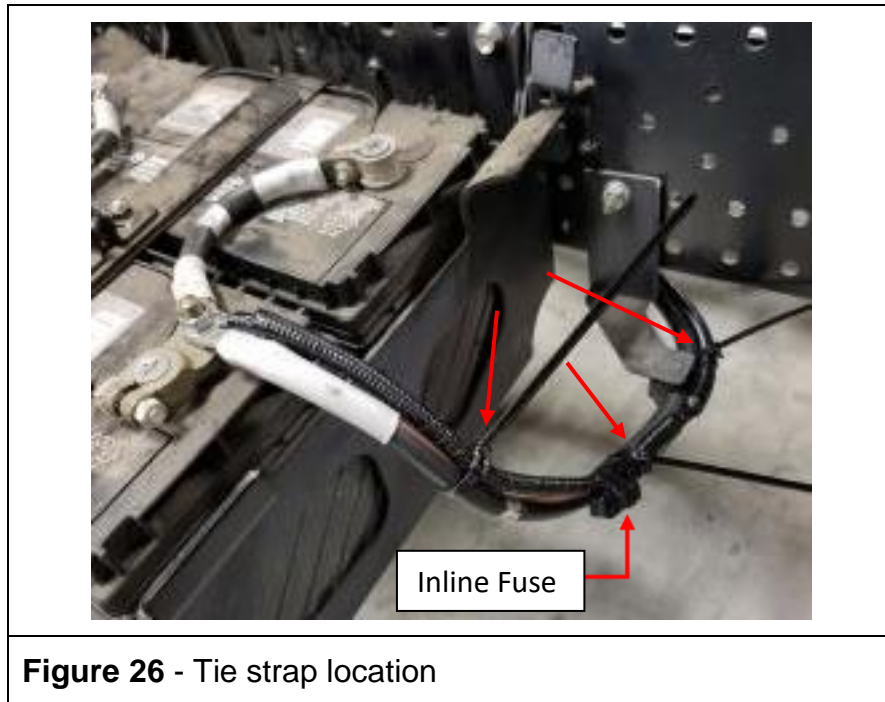
**Figure 24**

25. Route extension harness along front frame harness. A blue line in Figure 25 represents the extension harness. Install tie straps loosely every 9 ½" (250 mm) to hold the extension harness in place.



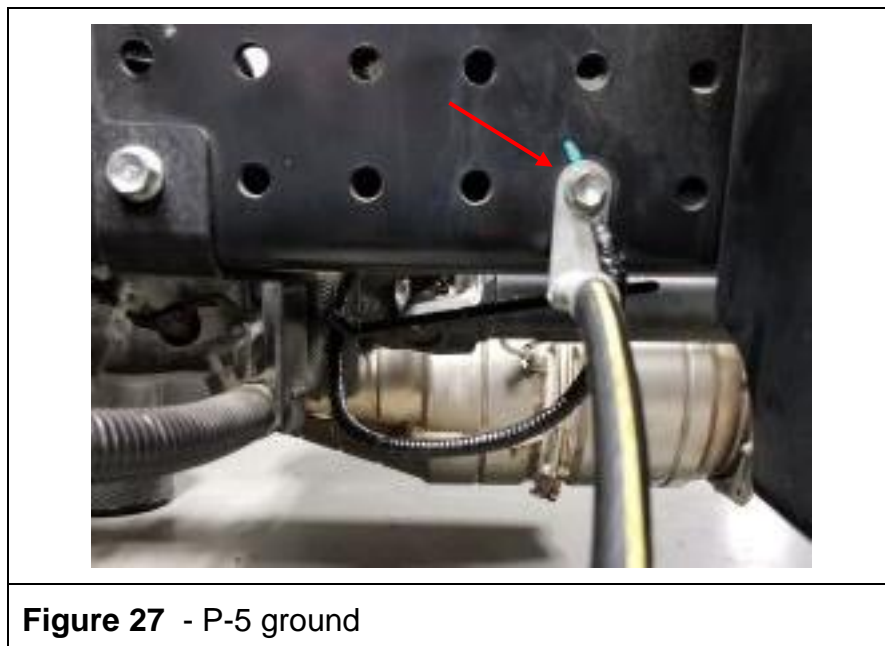
**Figure 25** – 2016 & 2017 MY vehicles do **not** have the Red/Black wire to the H-101 connector.

26. Attach the extension harness positive ring terminal to the battery positive (+) post and torque to 15 N•m or (11 lb•ft). Apply three (3) tie straps to secure the extension harness wiring to the battery positive cable as shown in Figure 26. The extension harness positive side contains an inline fuse.

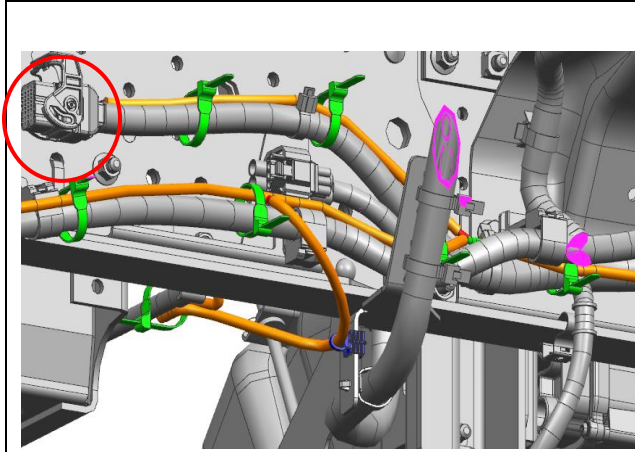


27. Attach the extension harness negative ring terminal to battery front frame ground P-5. (See Figure 27.)

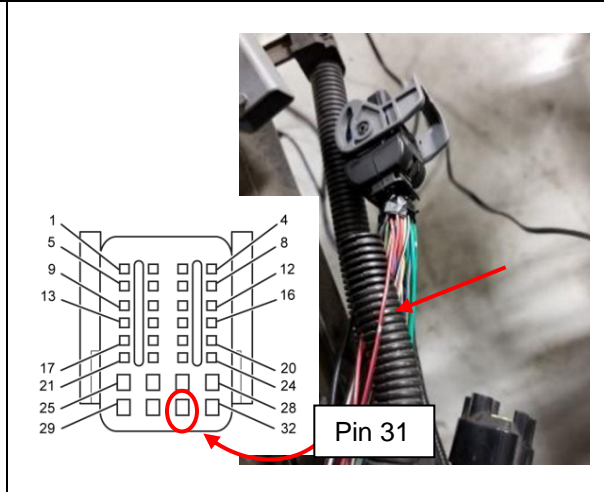
**CAUTION: Do not connect the negative (-) side terminal of the wire harness to the battery at this time.**



28. Route extension harness along the front frame harness and to the H-101 connector as shown in Figure 28. Apply tie straps loosely to hold harness in place. Disconnect the H-101 connector. On the front frame, harness side of the H-101 connector remove the electrical tape insulation and expose the red/black wire at pin 31. (See Figure 29.)



**Figure 28** – H-101 connector shown by red circle



**Figure 29** - Red/black wire leading to pin 31

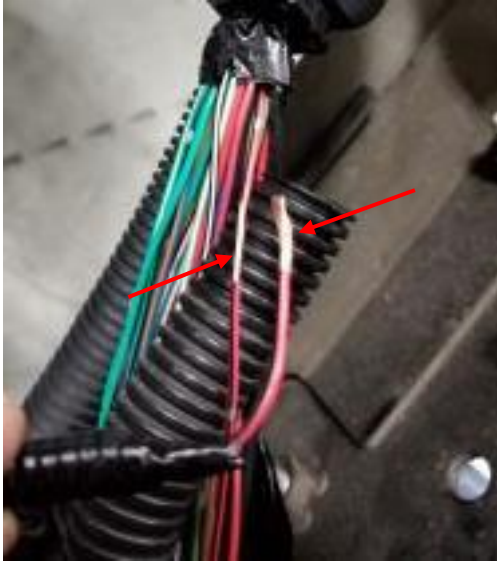
29. Using wire strippers, remove 15mm of insulation from the red/black wire 30mm to 45mm from the back of the H-101 connector on the front chassis harness. (See Figure 30.)

30. Use wire strippers to remove 15mm of insulation from the end of the red/black wire on the extension harness. (See Figure 30.)

**IMPORTANT: Do not cut wire in half in the main front frame harness while removing insulation.**

31. Use a soldering iron to solder the two wires together.

32. Use supplied mastic tape to wrap and insulate the exposed wiring, then cover with vinyl electrical tape as shown in Figure 31.



**Figure 30**

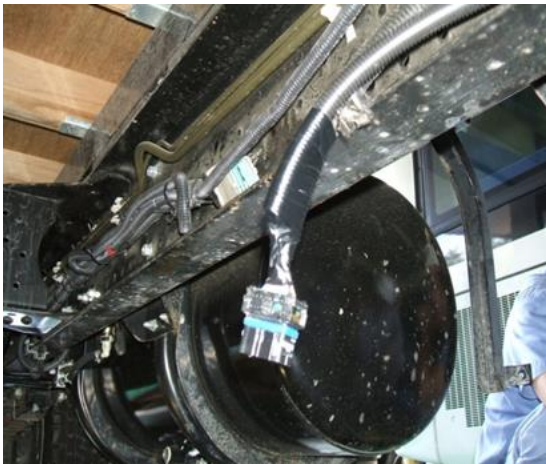


**Figure 31**

33. Re-secure the wiring into the wire loom protective cover. (See Figure 32.)

- Use vinyl electrical tape to wrap the harness where the ends of the wiring loom protective cover contact the electrical harness.
- Secure the wires into the loom ensuring that all exposed wiring is covered.
- Wrap the wiring loom protective cover with vinyl electrical tape.

34. On shorter wheel base trucks, extra extension harness will have to be bundled and secured. Apply tie straps to secure the wire bundle to the front frame harness as shown in Figure 33.

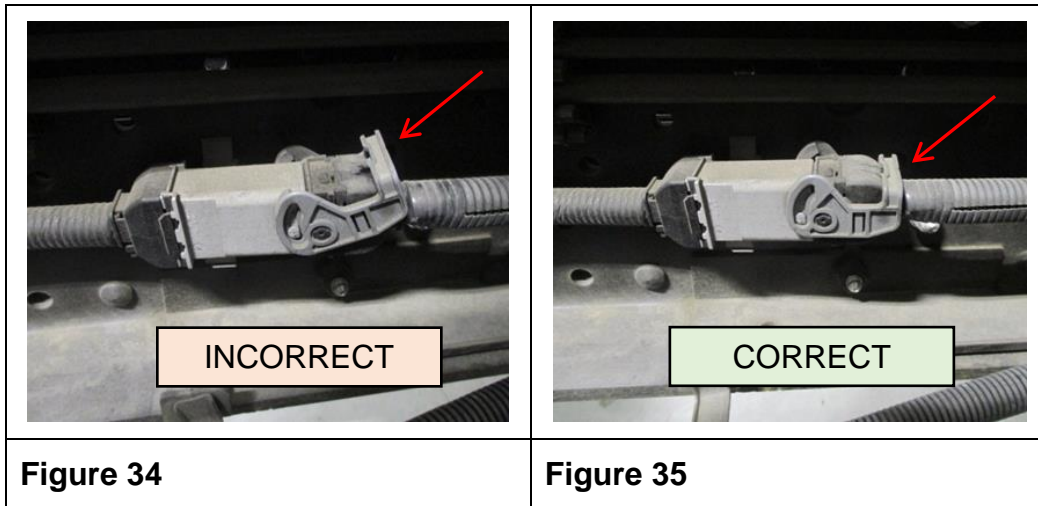


**Figure 32**



**Figure 33**

35. Reconnect the H-101 connector by fully seating the connector and placing the cam lock in the locked position. (See Figures 34 and 35.)

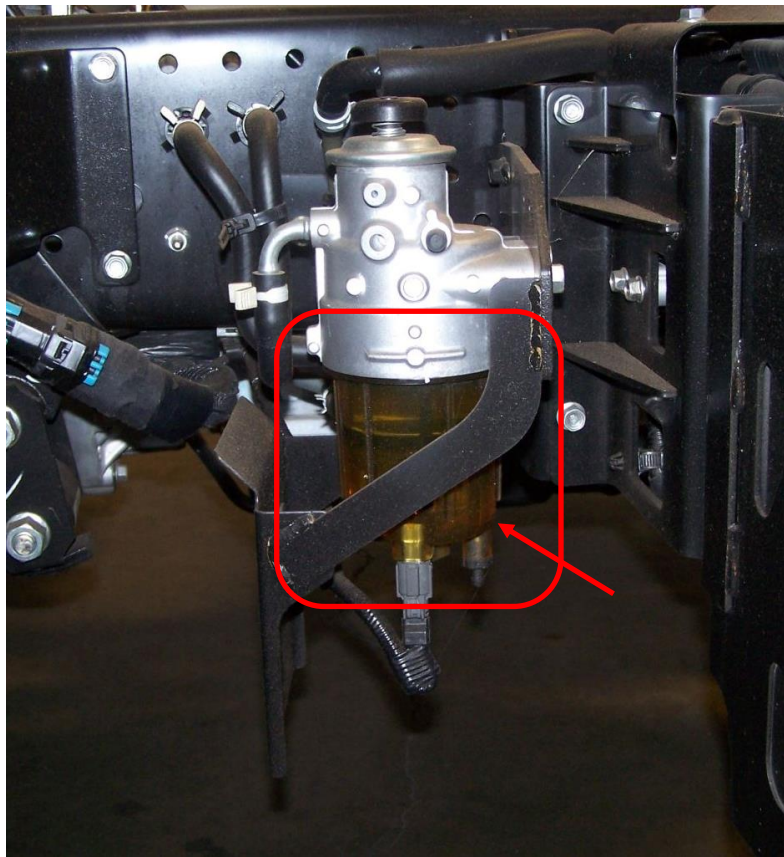


**CAUTION: Water intrusion may occur if the connector is not fully seated, resulting in electrical damage.**

36. Tighten the tie straps that were installed loosely in Step 25 along length of new extension harness.

37. Is the vehicle equipped with screw on clear bowl shown in Figure 36?

- Yes, perform Step 38 to Step 46 for installation of the CLEAR BOWL TO SEDIMENTER TO METAL KIT (Part number is listed under “Parts Information” at the beginning of this bulletin).
- No, skip to Step 47.

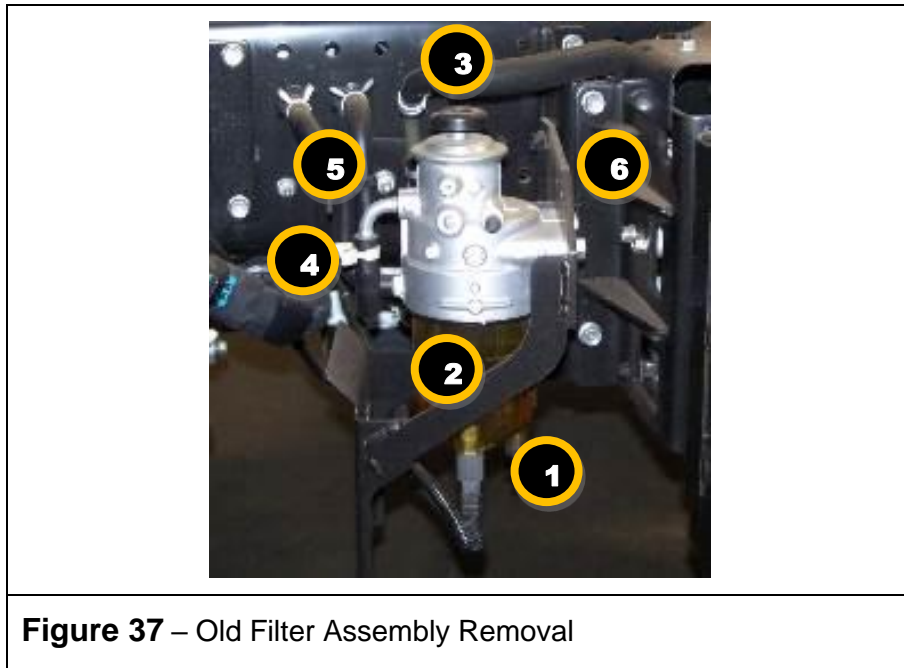


**Figure 36**

## **REMOVAL OF CLEAR BOWL ASSEMBLY**

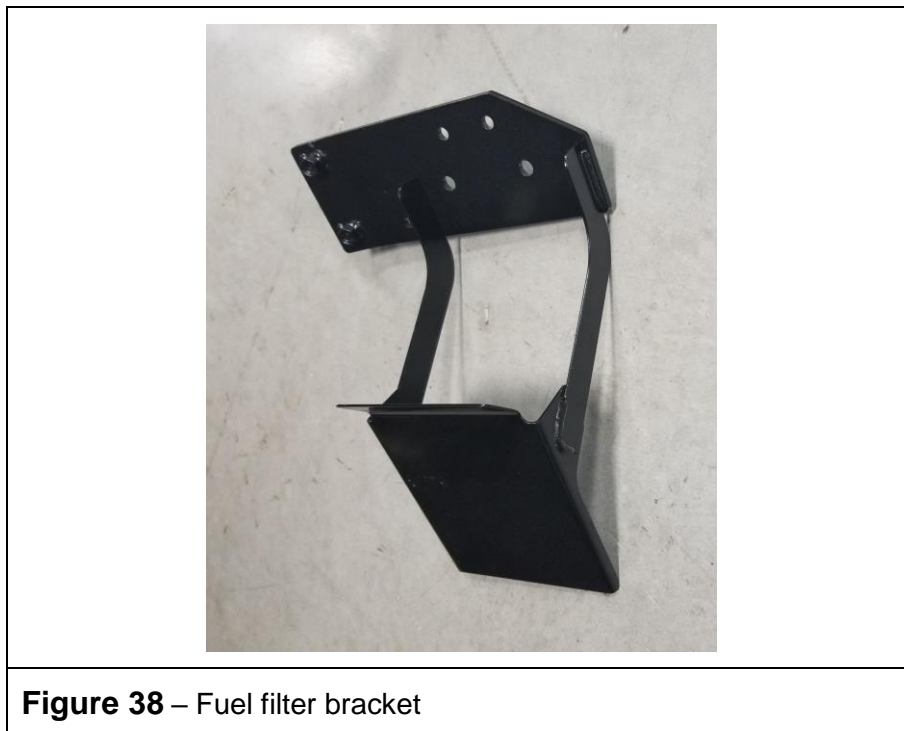
**Note: Be sure to place a drain tray on the ground underneath the sedimenter/pre-filter assembly area.**

38. Disconnect the sedimenter sensor. (See Figure 37, #1.)
39. Drain fuel in sedimenter. (See Figure 37, #2.)
40. On 2014 MY vehicles disconnect the DEF hose by removing the clip from DEF line and set aside to reuse. (See Figure 37, #3.)
41. Loosen the clamp and disconnect the fuel supply line at the filter housing. Save this supply line to reuse. (See Figure 37, #4.)
42. Loosen clamps and disconnect the fuel sedimenter from the supply pump fuel hose at the sedimenter. (See Figure 37, #5.)
43. Loosen and remove bolts from mounting bracket and remove the fuel sedimenter assembly along with old bracket. (See Figure 37, #6.)

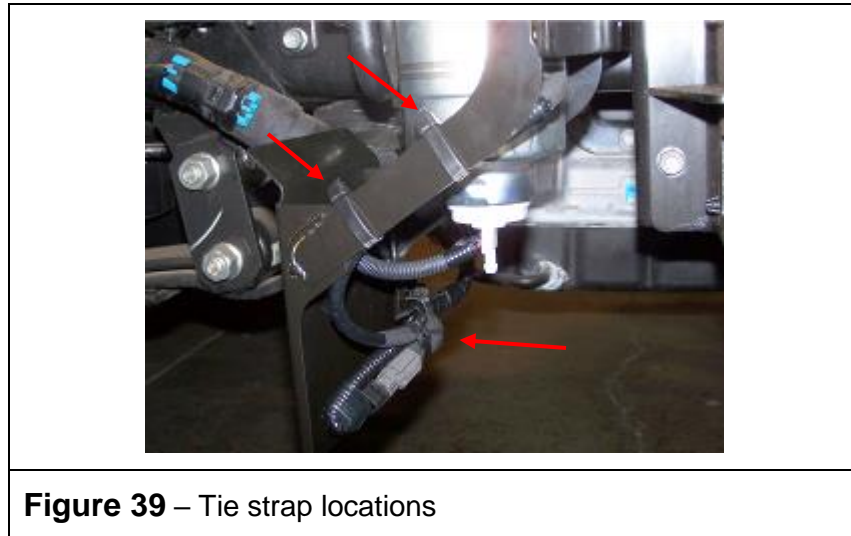


## INSTALLATION

44. Mount the new filter bracket onto the vehicle chassis bracket and torque to 41.4 Nm (37 lb ft). (See Figure 38.)



45. Remove and discard the old fuel pump supply hose and clamps. Drain fuel as necessary. Attach the new fuel pump supply hose to the fuel supply line and clip into place with the new hose clamps.
46. Secure the wiring harness with the new band clips/zip ties tucked against the sedimenter-mounting bracket. (See Figure 39.) Continue to Step 51.



**Figure 39** – Tie strap locations

#### **REMOVAL OF ORIGINAL FUEL SEDIMENTER ASSEMBLY**

47. Place a drain tray on the ground underneath the sedimenter/pre-filter assembly area. Drain fuel from sedimenter into the drain pan.
48. Disconnect the water sensor connector.
49. Loosen and move the fuel clamps and then remove the fuel inlet hose and fuel outlet hose at the filter sedimenter housing.
50. Remove the two (2) 12mm mounting bolts holding the fuel sedimenter to its mounting bracket. (See Figure 40.) Set bolts aside to use during re-assembly.



**Figure 40**

## INSTALLATION OF NEW HEATED FUEL SEDIMENTER ASSEMBLY

51. Inspect Heated Fuel Filter Kit for inventory. (See Figure 41.)



**Figure 41**

### Kit Contents

- Filter assembly with element
- Fuel sedimenter
- Banjo bolt (1) with gaskets (2)
- Spring clips (4)
- Band clip (1)
- Mastic tape (1)
- Tie straps (30)
- Extension harness kit (1) **not pictured**
- Relay: ISO; Micro (1) **not pictured**
- Relay: MR8 (1) **not pictured** (11-15MY only)

52. Mount the Heated Fuel Filter Sedimenter using the mounting bolts set aside during removal. Torque to 25Nm (18 lb•ft).

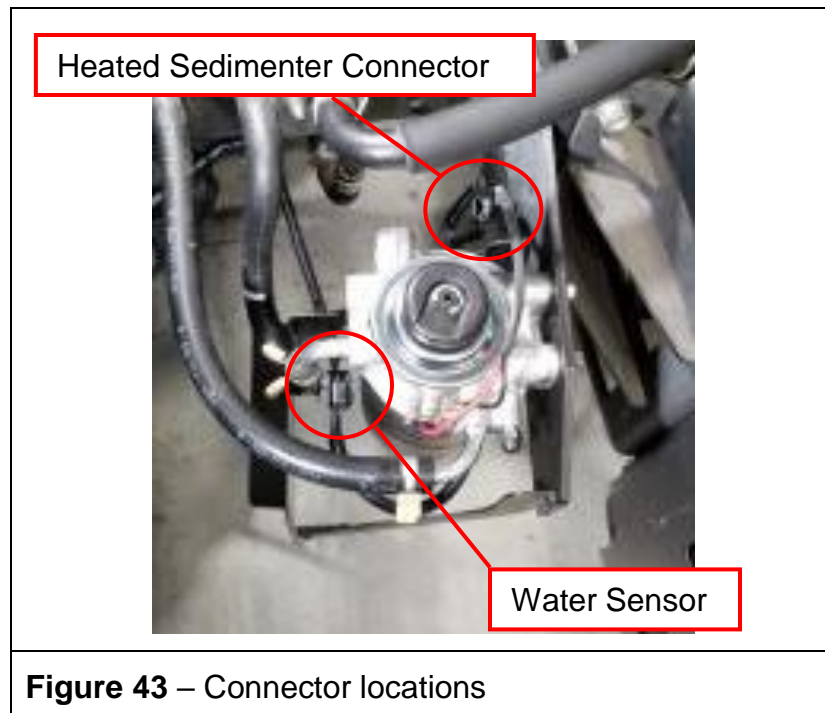
53. Reconnect the fuel inlet hose and outlet hose at the Sedimenter. Reposition hose clamps back onto the pipes. (See Figure 42.) For 2014MY reconnect the DEF hose and reposition hose clamps back into place.



**Figure 42**

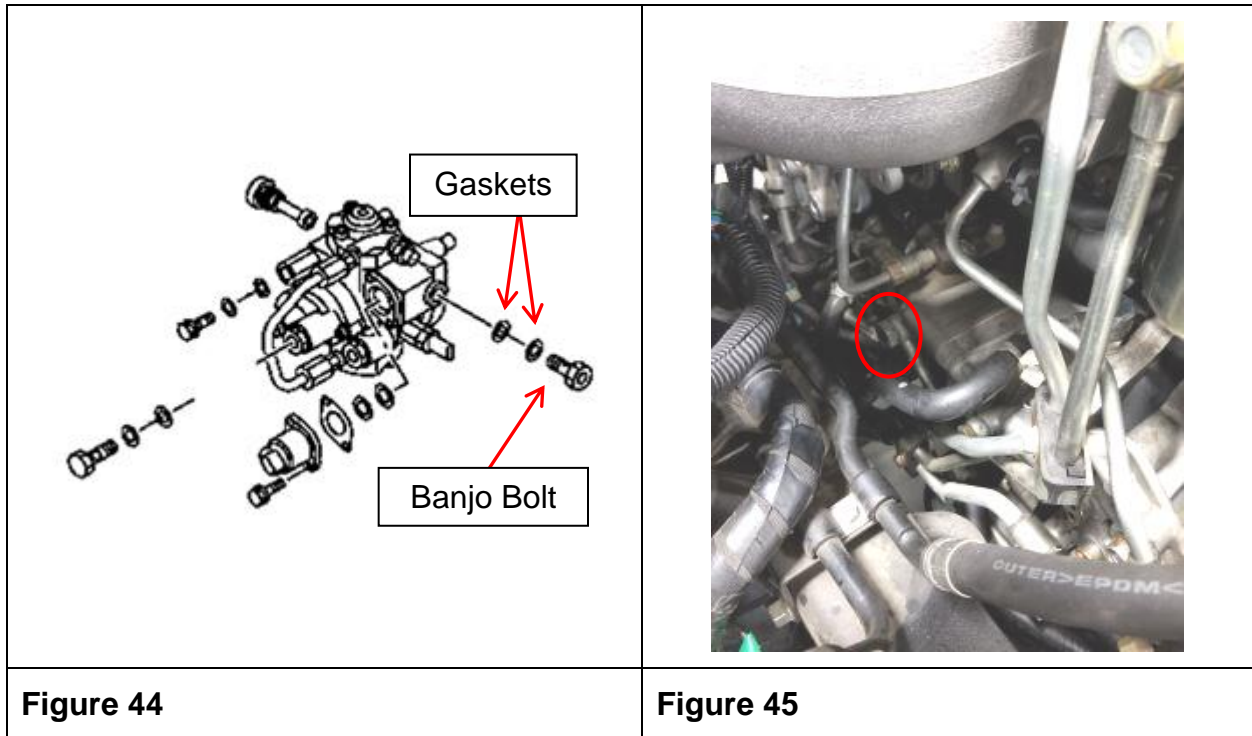
**NOTE: ENSURE NO TWISTS ARE PRESENT IN THE FUEL HOSES.**

54. Connect the water sensor and heated sedimenter connectors. (See Figure 43.)



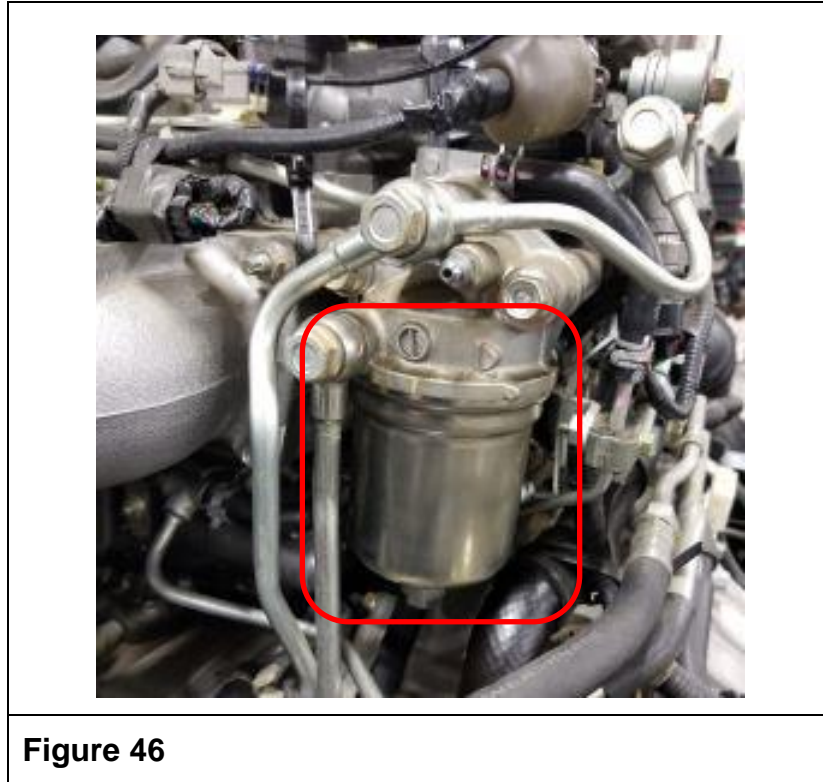
**Figure 43 – Connector locations**

55. Replace banjo bolt at fuel supply pump with new banjo bolt and two new gaskets and torque to 17 N•m (12.5 lb•ft). (See Figures 44 and 45.)



56. Replace main fuel filter element. (See Figure 46.)

**CAUTION: Use a catch pan to prevent any spillage of diesel fuel.**



57. Reconnect the negative (-) battery cable to the battery post. Torque to 15 N•m (11 lb•ft).

58. Bleed fuel system per the instructions in the applicable Isuzu WSM.

### **TEST HEATER CIRCUIT OPERATION**

59. Start the engine.

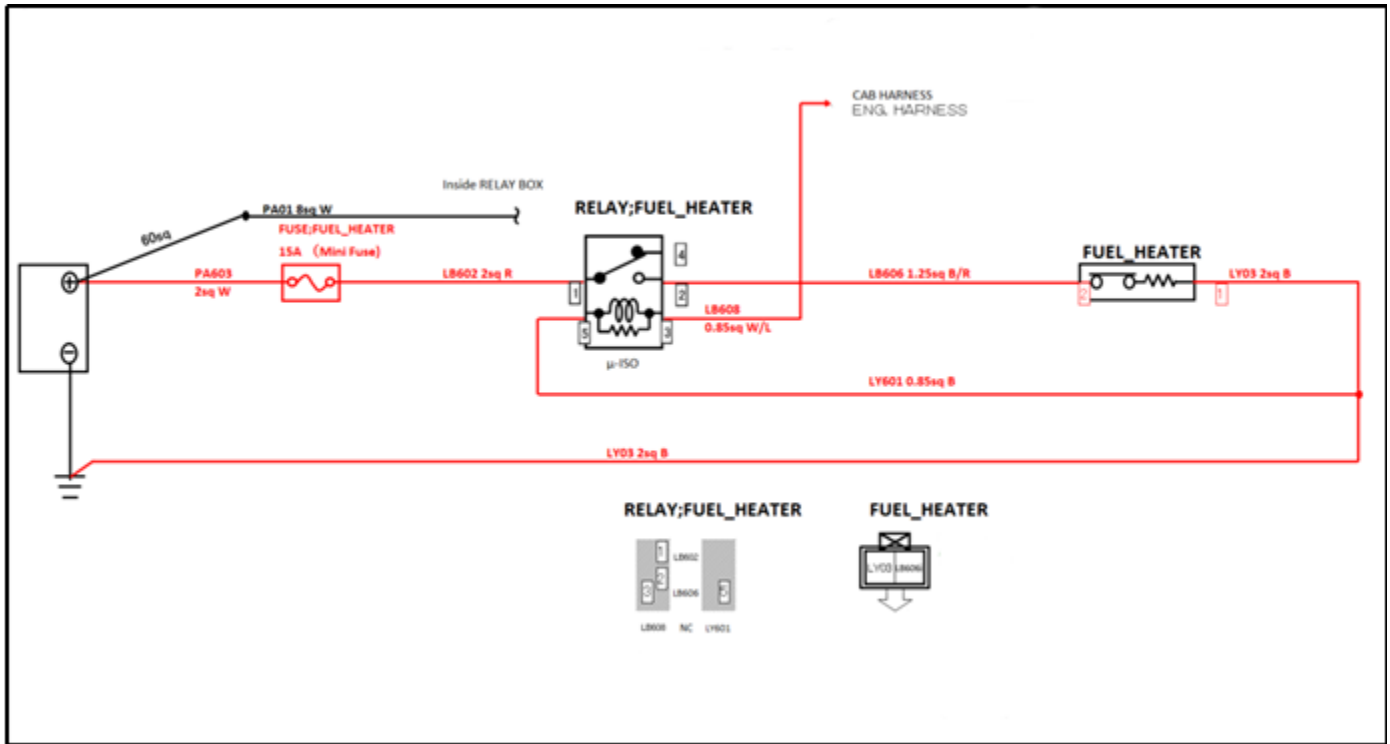
60. Disconnect the heated fuel sedimenter electrical connector located at the top of the fuel sedimenter and using a voltmeter verify that there is 12V to 14V present. (See Figure 43 at Step 54.)

- If there is no voltage or voltage is low, turn the engine control switch to the "OFF" position. Check for an Open circuit or Short circuit in the extension harness and perform repairs as necessary. When repairs are complete return to Step 59.
- If 12V to 14V output is present, reconnect the electrical connector. Turn off engine and continue to Step 61.

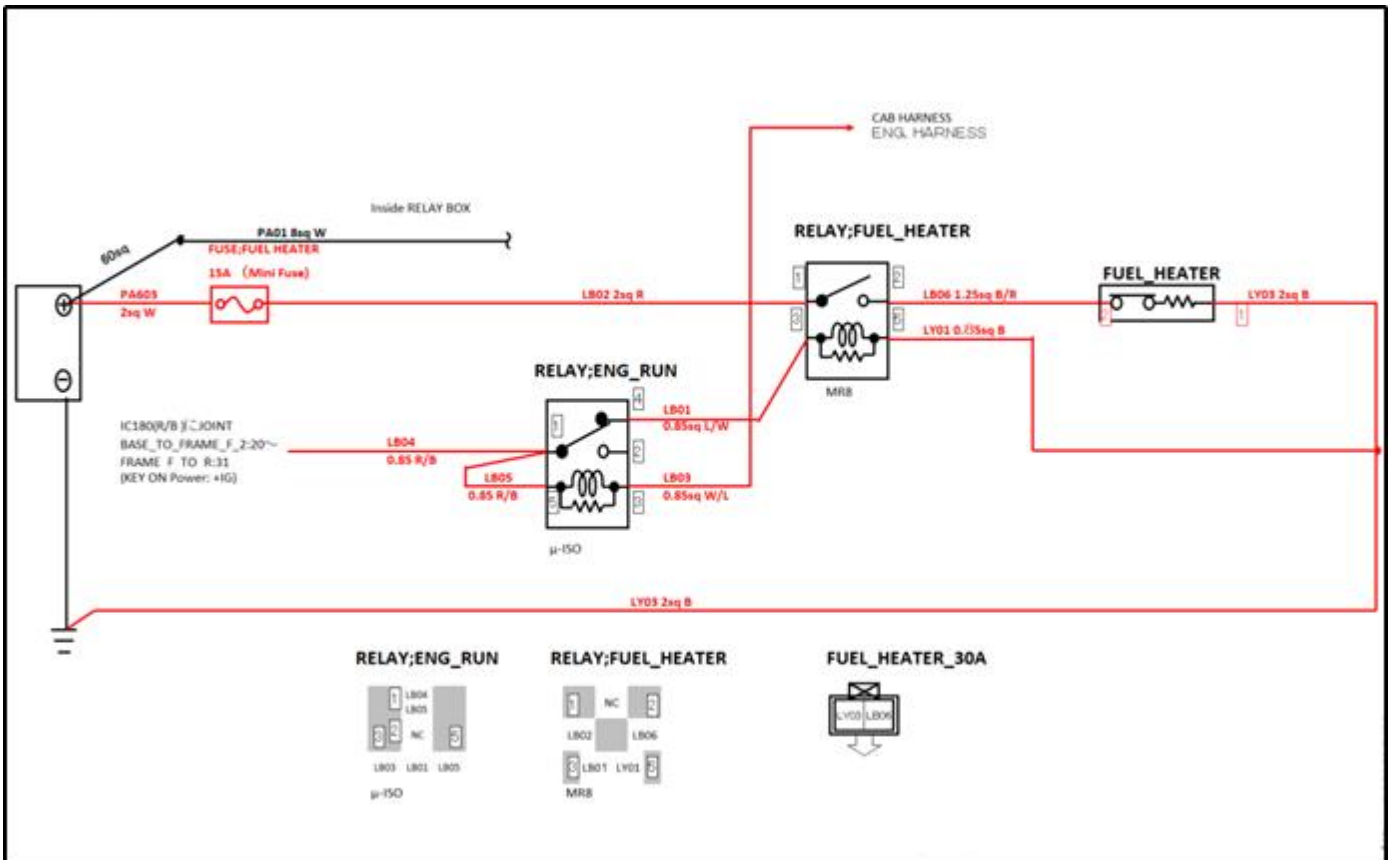
61. Installation is complete.

# FUEL HEATER WIRING SCHEMATIC

16MY-17MY

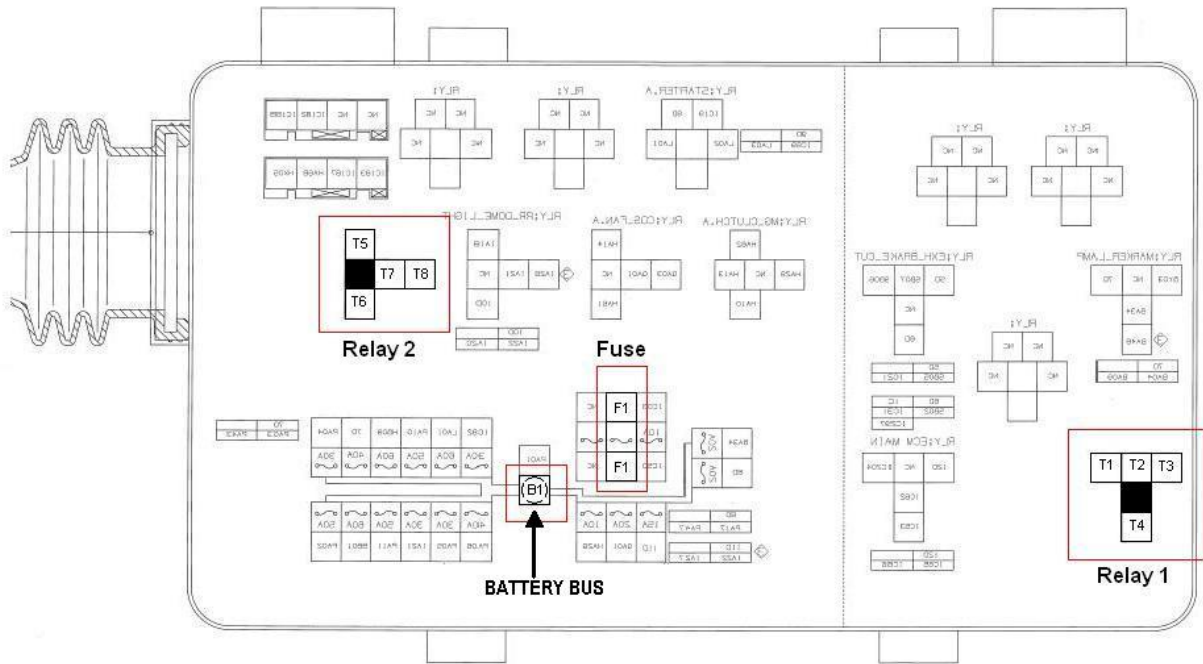
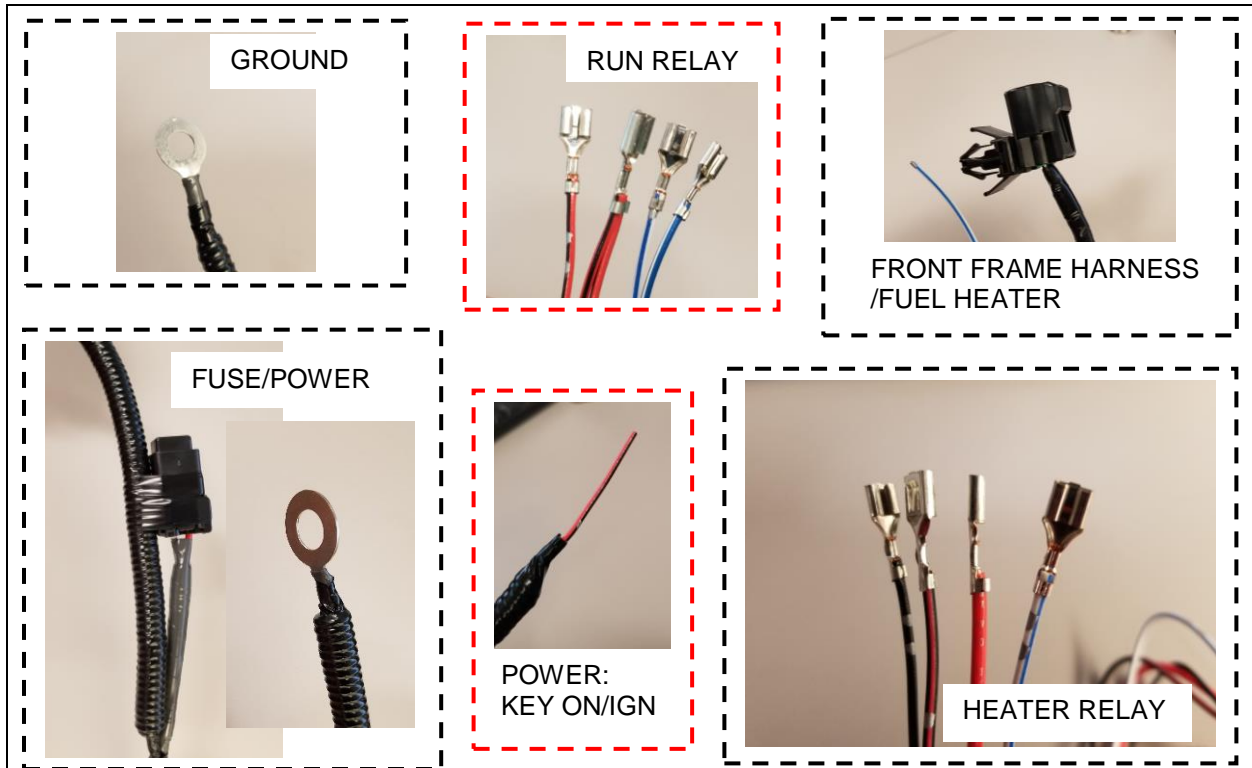


11MY-15MY



## HARNESS TERMINAL/FUSE BOX LOCATION ASSIGNMENTS

Component description	Harness description	Fuse box location	Comment
Run Relay 1	White/ Blue	T1	Small terminal, engine harness
Run Relay 1	Blue/ White	T2	Small terminal, fuel heater relay
Run Relay 1	Red/Black	T3	Small terminal, jumper wire
Run Relay 1	Red/Black	T4	Large terminal, front frame harness
Heater Relay 2	Blue/White	T5	Small terminal, to 15 Amp fuse
Heater Relay 2	Black	T6	Small terminal, ground
Heater Relay 2	Black/Red	T7	Large terminal, fuel heater relay
Heater Relay 2	White	T8	Large terminal, run relay
Heater Power	White	B1	Eyelet, battery bus
Heater Fuse	White	F1	Fuse Terminal
Heater Fuse	White	F1	Fuse Terminal
Heater Connector	2 wire	C1	Black Connector
Ground	Black	G1	Eyelet
Run Relay Power	Black/Red	S1	Splice
Run Relay Signal	Blue/White	S2	Splice



### 11MY-17MY Harness Connection by Location

Items outlined in red are only on 11-15MY vehicle harness.

## WARRANTY INFORMATION

The above noted condition is not a defect from manufacturing. The cost to add this secondary fuel filter kit to an Isuzu vehicle is not eligible for reimbursement under any Isuzu warranty.