

Technical Service Bulletin

Mazda North American Operations
Irvine, CA 92618-2922



Subject: MULTIPLE ELECTRICAL MALFUNCTIONS AFTER BODY REPAIR	Bulletin No.: 09-010/19
	Last Issued: 08/07/2019

BULLETIN NOTES

This bulletin supersedes the previously issued bulletin(s) listed below: The changes are noted below in red.

Previous TSBs:	Date(s) Issued:
09-010/19	02/05/2019
09-035/18	09/14/2018
09-059/16	11/29/2016
09-022/14	05/30/2014, 05/20/2014

APPLICABLE MODEL(S)/VINS

2016-2019 CX-3
2013-2019 CX-5
2016-2019 Mazda2
2014-2018 Mazda3
2014-2019 Mazda6

DESCRIPTION

Some customers may experience one or more electrical malfunctions after a vehicle body repair. The newly painted fender stay (2) may be causing a poor front harness (1) ground connection.

CONSUMER NOTICE: The information and instructions in this bulletin are intended for use by skilled technicians. Mazda technicians utilize the proper tools/equipment and take training to correctly and safely maintain Mazda vehicles. These instructions should not be performed by "do-it-yourselfers." Customers should not assume this bulletin applies to their vehicle or that their vehicle will develop the described concern. To determine if the information applies, customers should contact their nearest authorized Mazda dealership. Mazda North American Operations reserves the right to alter the specifications and contents of this bulletin without obligation or advance notice. All rights reserved. No part of this bulletin may be reproduced in any form or by any means, electronic or mechanical---including photocopying and recording and the use of any kind of information storage and retrieval system ---without permission in writing.

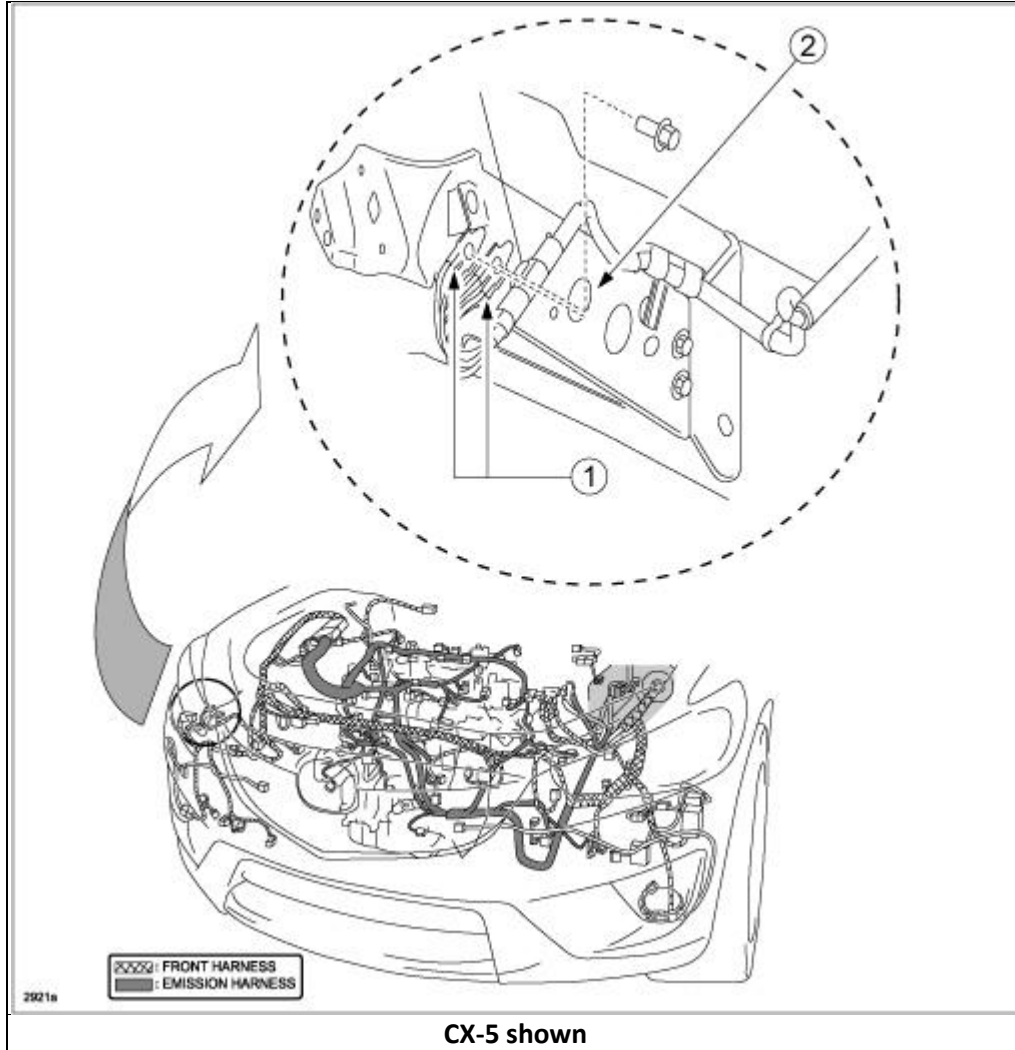

CONSUMER NOTICE: The information and instructions in this bulletin are intended for use by skilled technicians. Mazda technicians utilize the proper tools/equipment and take training to correctly and safely maintain Mazda vehicles. These instructions should not be performed by "do-it-yourselfers." Customers should not assume this bulletin applies to their vehicle or that their vehicle will develop the described concern. To determine if the information applies, customers should contact their nearest authorized Mazda dealership. Mazda North American Operations reserves the right to alter the specifications and contents of this bulletin without obligation or advance notice. All rights reserved. No part of this bulletin may be reproduced in any form or by any means, electronic or mechanical---including photocopying and recording and the use of any kind of information storage and retrieval system ---without permission in writing.

MODEL	YEAR	SYMPTOMS
CX-5	2013- 2019	<p>Symptom 1:</p> <ul style="list-style-type: none"> • The customer states: <ul style="list-style-type: none"> - Headlights flash ON and OFF - Check engine light ON - Heater blower stopped - Engine stalled • During the dealer visit, the engine had a slow crank and no start. After charging the battery, the engine starts and the symptoms related to headlight and heater blower operation are duplicated.
		<p>Symptom 2:</p> <ul style="list-style-type: none"> • The customer states that the engine stalled while driving and does not restart. • Vehicle inspection finds: <ul style="list-style-type: none"> - M-MDS cannot identify the vehicle - Electric cooling fans are ON - Ignition cannot be turned OFF - Multiple warning lights in the instrument cluster are ON
Mazda3	2014- 2018	<p>Immediately after body repair (front fender stay), the following instrument cluster warning lights are ON:</p> <ul style="list-style-type: none"> • ABS, Brake, DSC TPMS • DTC U3003:16 - Battery Power Supply
Mazda6	2014- 2019	<p>Symptom 1:</p> <ul style="list-style-type: none"> • The customer states that multiple warning lights in the instrument cluster are ON while driving. • Multiple DTCs are stored in multiple modules' memory: <ul style="list-style-type: none"> - C0023:62, C1001:92, U0121:00 [EPS], U0121:00 [IC], U0121:00 [SCB], U0121:00 [PCM], U0121:00 [SSU], U0401 [BSM], U0415:00, U2005:86 [FSC]
		<p>Symptom 2:</p> <ul style="list-style-type: none"> • Gear shift indicator is not activated if vehicle is started by push button start.
Mazda2	2016- 2019	<ul style="list-style-type: none"> • Windshield wipers turn on by themselves when front turn lights or other front lights are on. <ul style="list-style-type: none"> • No DTCs are stored in memory.
CX-3	2016- 2019	<ul style="list-style-type: none"> • Windshield wipers turn on by themselves when front turn lights or other front lights are on. <ul style="list-style-type: none"> • No DTCs are stored in memory.

The front fender stay (2) newly painted surface at ground point (3), where attachment bolt (4) is seated, may create a poor front harness ground connection.

CONSUMER NOTICE: The information and instructions in this bulletin are intended for use by skilled technicians. Mazda technicians utilize the proper tools/equipment and take training to correctly and safely maintain Mazda vehicles. These instructions should not be performed by "do-it-yourselfers." Customers should not assume this bulletin applies to their vehicle or that their vehicle will develop the described concern. To determine if the information applies, customers should contact their nearest authorized Mazda dealership. Mazda North American Operations reserves the right to alter the specifications and contents of this bulletin without obligation or advance notice. All rights reserved. No part of this bulletin may be reproduced in any form or by any means, electronic or mechanical---including photocopying and recording and the use of any kind of information storage and retrieval system ---without permission in writing.

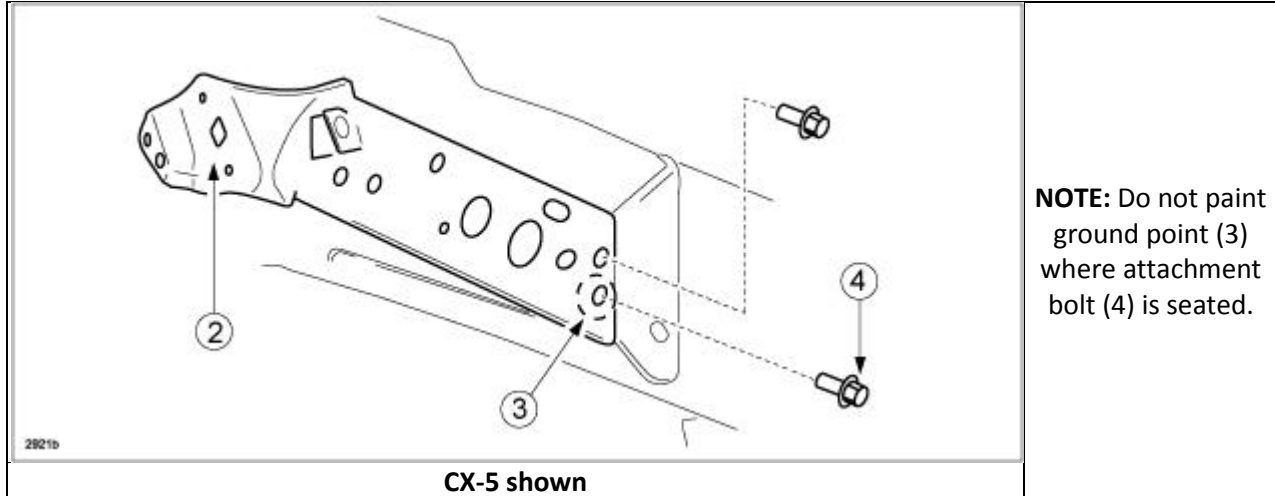

Customers concern can be resolved by sanding off paint at ground point (3) where attachment bolt (4) is seated. After installing the bolt (4), apply touch-up paint to the exposed base material area of the front fender stay.

NEWLY INSTALLED FRONT FENDER STAY NOTE:

CAUTION: If the bolt (4) contact area (3) is painted when the front fender stay (2) is newly replaced, it could cause a malfunction in the PCM. Before painting a newly replaced part, protect the bolt (4) contact area (3) with masking tape (5) as shown in the figure.

CONSUMER NOTICE: The information and instructions in this bulletin are intended for use by skilled technicians. Mazda technicians utilize the proper tools/equipment and take training to correctly and safely maintain Mazda vehicles. These instructions should not be performed by "do-it-yourselfers." Customers should not assume this bulletin applies to their vehicle or that their vehicle will develop the described concern. To determine if the information applies, customers should contact their nearest authorized Mazda dealership. Mazda North American Operations reserves the right to alter the specifications and contents of this bulletin without obligation or advance notice. All rights reserved. No part of this bulletin may be reproduced in any form or by any means, electronic or mechanical---including photocopying and recording and the use of any kind of information storage and retrieval system ---without permission in writing.

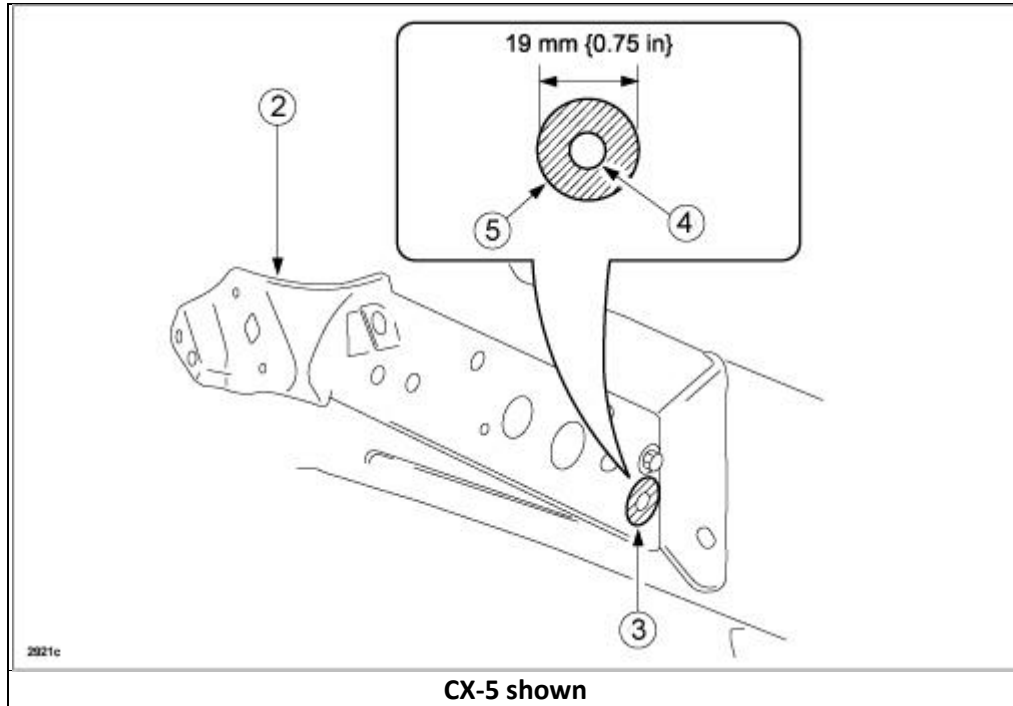

NOTE: After installing the bolt (4), apply touch-up paint to the exposed base material area of the front fender stay.

NOTE: Always replace the ground bolt (1) if the Workshop Manual or Bodyshop Manual instructs to use the ground bolt for proper grounding.

CONSUMER NOTICE: The information and instructions in this bulletin are intended for use by skilled technicians. Mazda technicians utilize the proper tools/equipment and take training to correctly and safely maintain Mazda vehicles. These instructions should not be performed by "do-it-yourselfers." Customers should not assume this bulletin applies to their vehicle or that their vehicle will develop the described concern. To determine if the information applies, customers should contact their nearest authorized Mazda dealership. Mazda North American Operations reserves the right to alter the specifications and contents of this bulletin without obligation or advance notice. All rights reserved. No part of this bulletin may be reproduced in any form or by any means, electronic or mechanical---including photocopying and recording and the use of any kind of information storage and retrieval system ---without permission in writing.

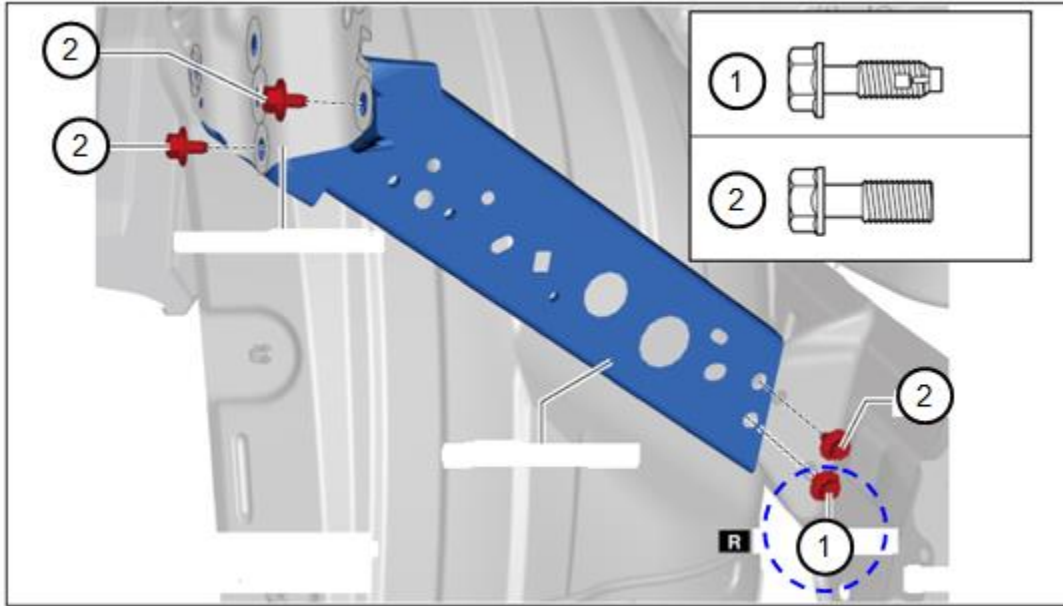

Ground bolt (1)
Mounting bolt (2)

WARRANTY COMPLIANCE NOTE:

Vehicle repairs for this concern are not covered under Mazda’s warranty policy.

CONSUMER NOTICE: The information and instructions in this bulletin are intended for use by skilled technicians. Mazda technicians utilize the proper tools/equipment and take training to correctly and safely maintain Mazda vehicles. These instructions should not be performed by “do-it-yourselfers.” Customers should not assume this bulletin applies to their vehicle or that their vehicle will develop the described concern. To determine if the information applies, customers should contact their nearest authorized Mazda dealership. Mazda North American Operations reserves the right to alter the specifications and contents of this bulletin without obligation or advance notice. All rights reserved. No part of this bulletin may be reproduced in any form or by any means, electronic or mechanical---including photocopying and recording and the use of any kind of information storage and retrieval system ---without permission in writing.