

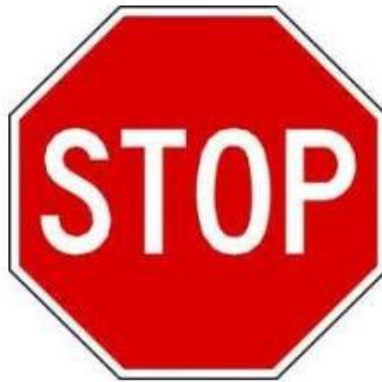

DETROITTM
DEMAND PERFORMANCESM

**18SP729Rev –Three-Filter Fuel
System DD15/16 High Pressure Fuel Feed
Lines, Mounting Bracket and P-clips Service Kit (P/N:
A0000701532)**



WARNING:

PERSONAL INJURY

All parts provided within this kit **MUST** be installed in the proper locations, and **MUST** be fastened to the specified torque. Failure to properly torque hardware/components will result in failure of a high pressure fuel feed line, resulting in possible fire and/or personal injury.



WARNING:

PERSONAL INJURY

All parts provided with this kit, and those they are replacing on the engine, function as a complete system and are single-use items. The old parts cannot be reused. Reusing parts or failing to use all new parts contained in the kit may result in the failure of high pressure fuel lines, possibly resulting in a fire.

NOTICE: Failure to follow these instructions will result in catastrophic damage to the engine and will not be covered under warranty.

KIT DESCRIPTION

This service kit includes all necessary parts to replace the high pressure fuel rail feed lines, mounting bracket, P-clips and mounting hardware in the event one of these parts are loosened, removed or missing from the engine.

KIT CONTENTS

Service kit P/N: A0000701532 contains all of the necessary parts to replace the high pressure fuel feed lines on three-filter fuel system DD15/16 engines.

Part No.	Qty.	Description
A4720780310	2	High pressure fuel feed line
A4720700540	2	P-Clip
N000000007957	2	Bolt M6x12mm
N910105006024	1	Bolt M6x20mm
N910105008011	2	Bolt M8x20mm
A4730700440	1	Return lines triple-clip
A4720701040	1	Mounting bracket
18SP729	1	Installation Instructions

Removal of the High Pressure Fuel Rail Feed Lines - Three-Filter System

Remove as follows:

NOTICE: The high pressure fuel rail feed lines, vibration dampers, P-clips, mounting bracket and hardware are one-time use components and **MUST** be replaced any time they are removed or loosened. Refer to TS letter 16 TS-9 Rev2 (<http://dtna.info/16ts9>) for the high pressure fuel line kit numbers.



WARNING:

PERSONAL INJURY

To prevent the escape of high pressure fuel that can penetrate skin, ensure the engine has been shut down for a minimum of 10 minutes before servicing any component within the high pressure circuit. Residual high fuel pressure may be present within the circuit.

Engines with a serial number before 472901S0012796

Item	Component
1	Mounting bracket
2	Mounting bracket bolts
3	Return lines P-clip and bolt
4	Vibration dampers and bolts
5	High pressure fuel feed lines
6	P-clips and bolts

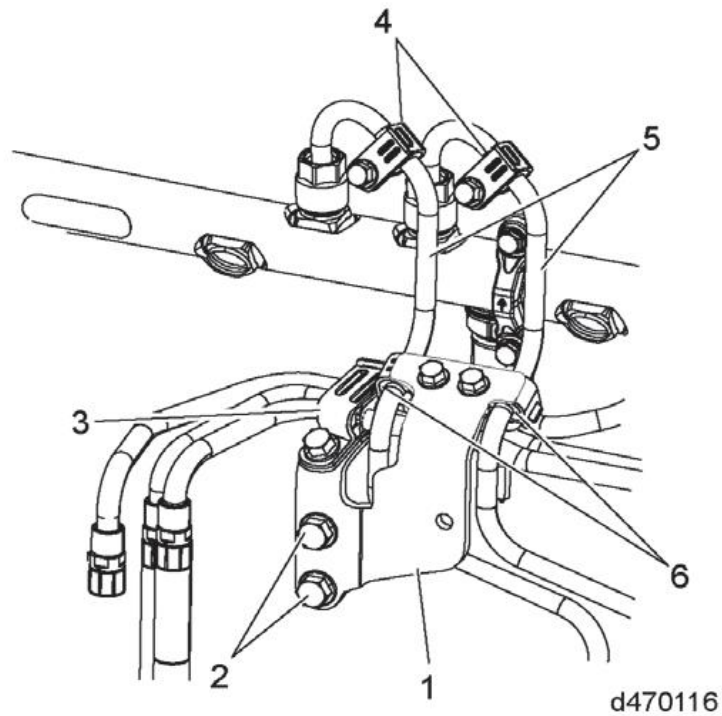

Engines with a serial number after 472901S0012796

Item	Component
1	Mounting bracket
2	Mounting bracket bolts
3	Return lines P-clip and bolt
4	Vibration dampers and bolts (Or permanent)
5	High pressure fuel feed lines
6	P-clips and bolts

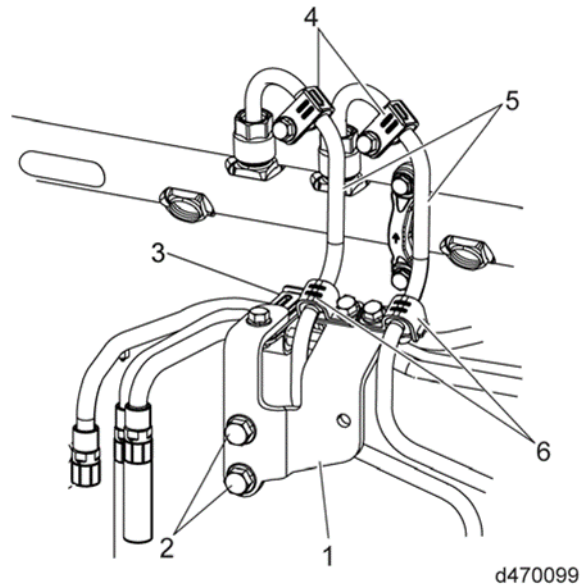

1. Shut off the engine, apply the parking brake, chock the wheels, and perform any other applicable safety steps.



CAUTION:

ELECTRICAL SHOCK

To avoid injury from electrical shock, use care when disconnecting battery cables. The magnetic switch studs are at battery voltage.

2. Disconnect the batteries.
3. Open the hood.
4. If necessary, remove the bumper. Refer to the Original Equipment Manufacturer (OEM) procedures.
5. If necessary for access, remove the air cleaner. Refer to the (OEM) procedures.
6. Remove and discard the return lines P-clip bolt from the mounting bracket (1).

NOTE: The graphic below illustrates the DD15/16 engines with a serial number before 472901S0012796.

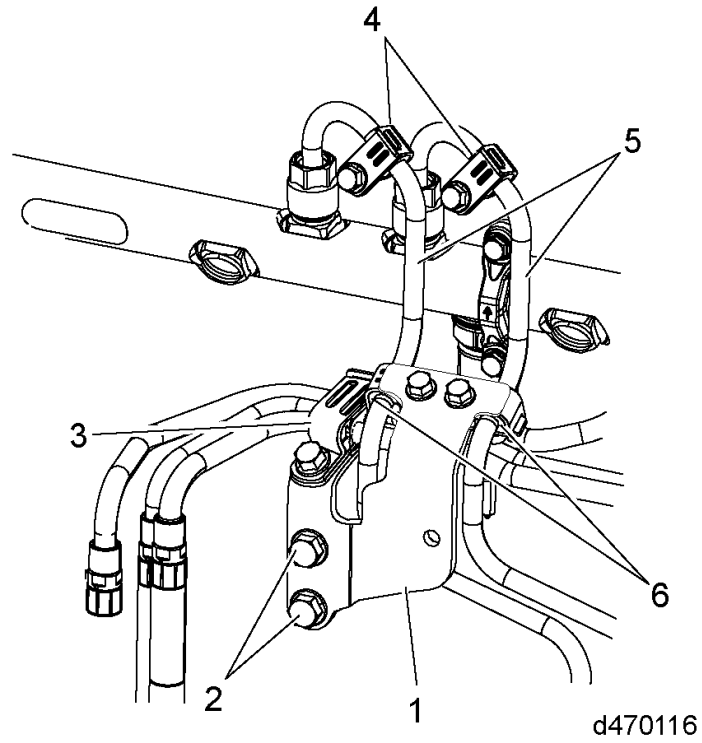

NOTE: The graphic below illustrates a DD15/16 engines with a serial number after 472901S0012796 and all DD13 engines.

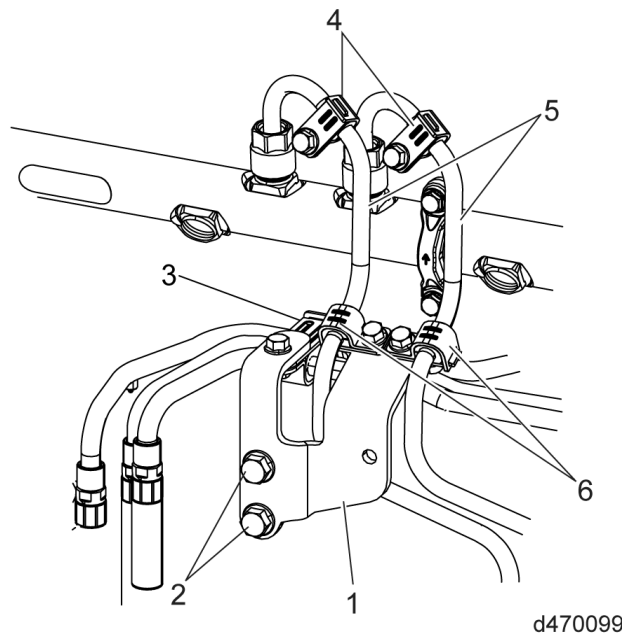

NOTE: The graphic below illustrates DD engines with permanent vibration dampers on the high pressure fuel rail feed lines.

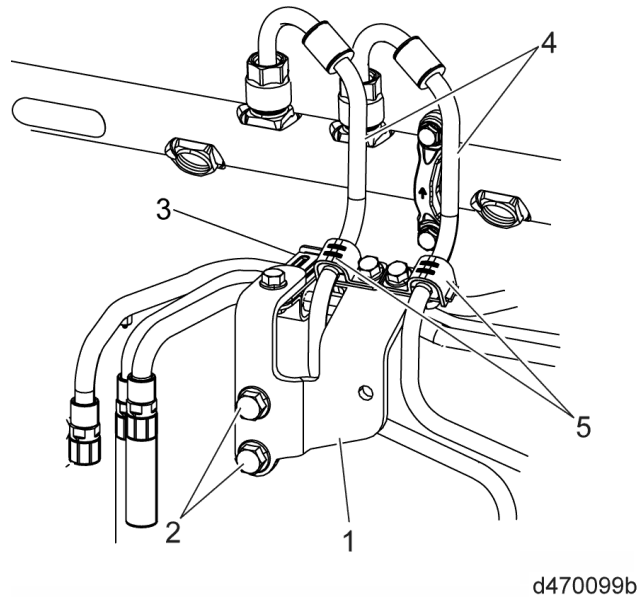

7. Remove and discard the two P-clip bolts from the mounting bracket.
8. Remove and discard the mounting bracket bolts (2) from the intake manifold and discard the mounting bracket (1).

NOTE: When removing the high pressure fuel rail feed lines, hold the high pressure pump fitting with a 24mm wrench. If the high pressure pump fittings are loosened while removing the high pressure fuel rail feed lines, re-torque the fittings to 75 N·m (55 lb·ft).

9. For high pressure fuel rail feed lines with bolted vibration dampers, remove and discard the high pressure fuel rail feed lines (5), vibration dampers (4), and P-clips from the fuel rail and high pressure fuel pump. For high pressure fuel rail feed lines with permanent vibration dampers, remove and discard the high pressure fuel rail feed lines (4), vibration dampers, and P-clips (5) from the fuel rail and high pressure fuel pump.
10. Remove and discard the return lines triple-clip (3).

Installation of the DD15 and DD16 High Pressure Fuel Rail Feed Lines - Three-Filter System

Install as follows:

NOTE: New high pressure fuel rail feed lines have permanent vibration dampers.

NOTICE: The high pressure fuel rail feed lines, vibration dampers, P-clips, mounting bracket and hardware are one-time use components and **MUST** be replaced any time they are removed or loosened. Refer to TS letter 16 TS-9 Rev2 (<http://dtna.info/16ts9>) for the high pressure fuel line kit numbers.



NOTE: DO NOT install bolts and fittings using power tools. All bolts and fittings **MUST** be installed using hand tools.



WARNING:

PERSONAL INJURY

All hardware/components **MUST** be installed in the proper locations, and **MUST** be fastened to the specified torque. Failure to properly torque hardware/components will result in failure of a high pressure fuel feed line, resulting in possible fire and/or personal injury.

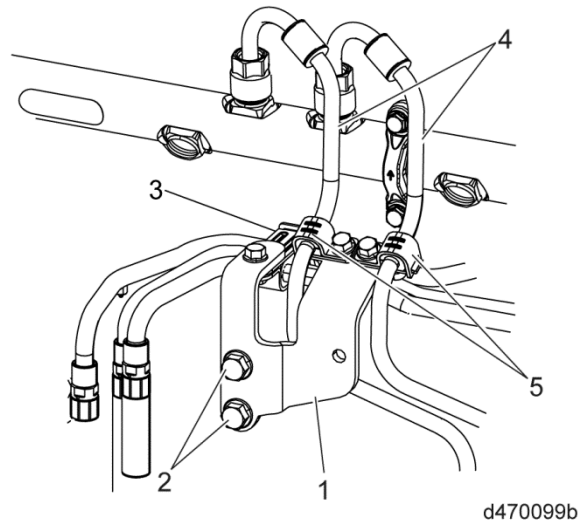

Item	Component	Part number
1	Mounting bracket	A4720701040
2	Mounting bracket bolts	N910105008011
3	Return lines P-clip and bolt	A4730700440 and N910105006024
4	High pressure fuel feed lines	A4720780310
5	P-clips and bolts	A4720700540 and N000000007957

1. Install new return lines triple-clip (3) onto the return lines.

NOTE: The graphic below illustrates the DD15/16 engines with a serial number before 472901S0012796.

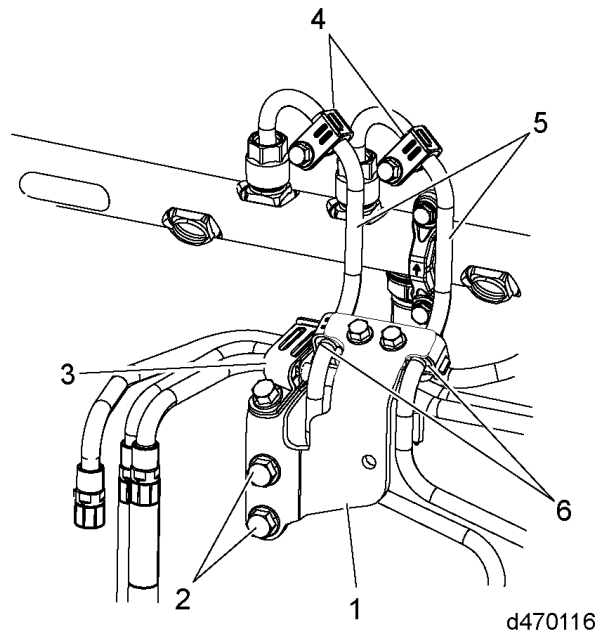

NOTE: The graphic below illustrates a DD15/16 engines with a serial number after 472901S0012796 and all DD13 engines.

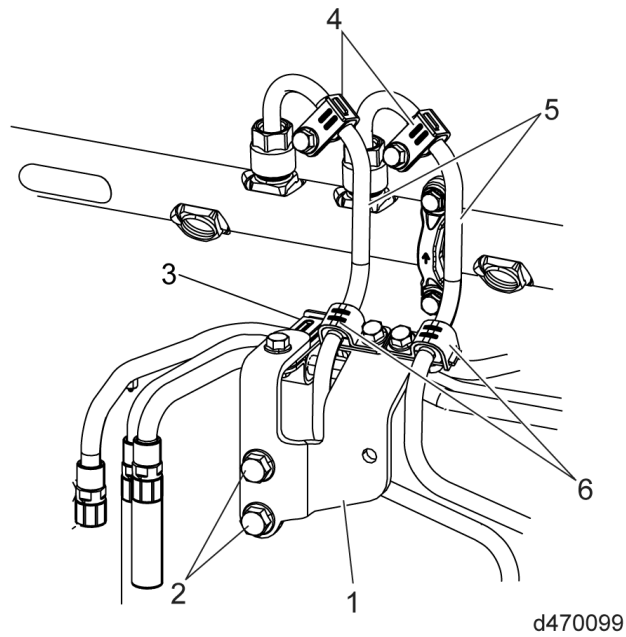

NOTE: The graphic below illustrates DD engines with permanent vibration dampers on the high pressure fuel rail feed lines.

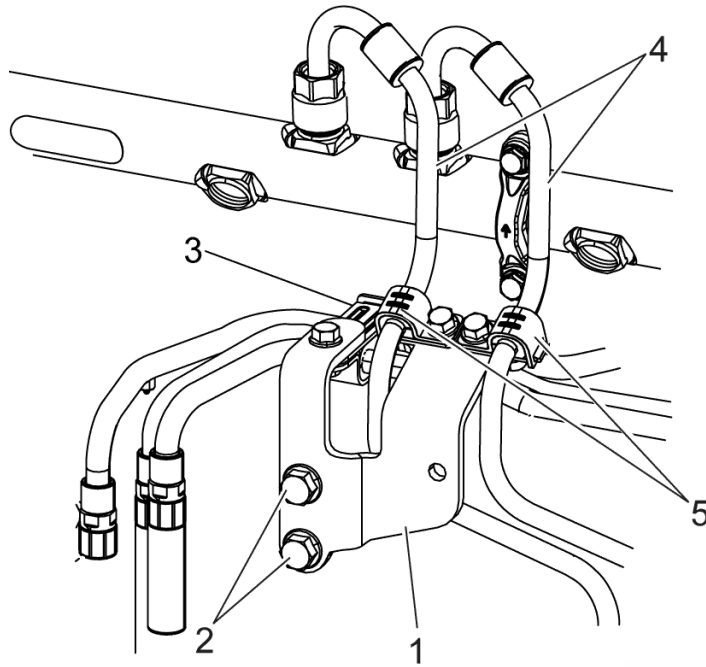

d470099b

2. Clean the sealing area inside the high pressure fuel pump outlet fittings using a clean lint-free cloth. The photo shown below is of KM59 GEN1 High Pressure Fuel Pump Fittings.



d470166

3. Clean the sealing area inside the high pressure fuel rail using a clean lint-free cloth. The photo shown below is of KM59 GEN1 high pressure fuel rail fittings.



NOTE: New P-clip MUST be installed onto the high pressure fuel rail feed lines with the lower P-clip plate (1) inserted into the P-clip window (2); see graphic below.

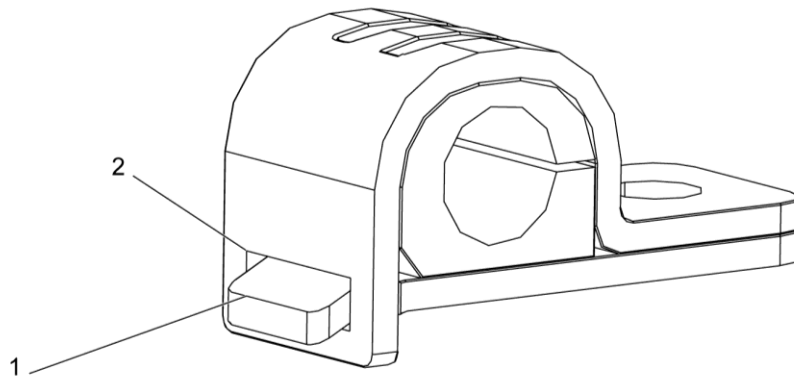

d470247

4. Install both of the new P-clips, one each, onto the high pressure fuel rail feed lines; see graphic below.

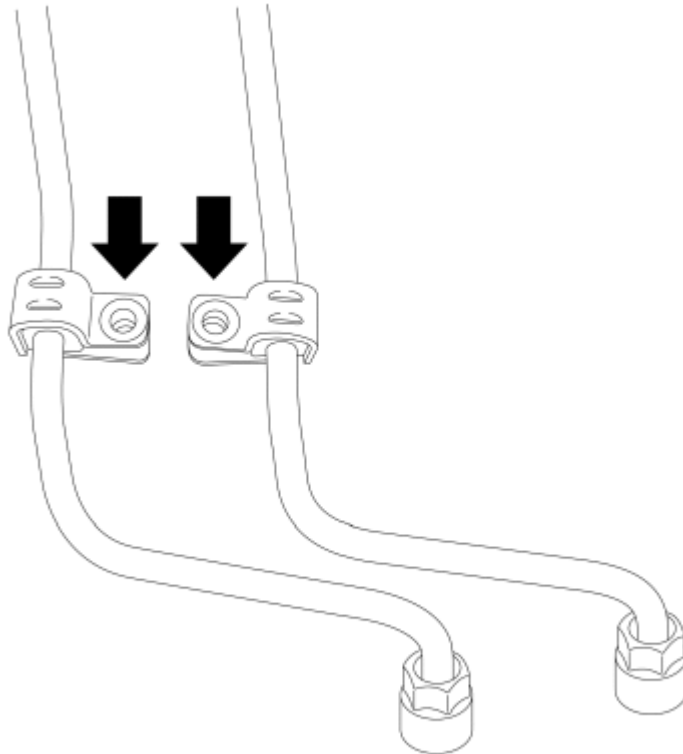

d470315

NOTE: DO NOT use new high pressure fuel rail feed lines that do not have new vibration dampers installed.

5. Position the rear high pressure fuel rail feed line into the fuel rail and the high pressure fuel pump. Do not start the threads of the fuel line nuts at this point.
6. Position the front high pressure fuel rail feed line into the fuel rail and the high pressure fuel pump. Do not start the threads of the fuel line nuts at this point.

7. Install the new mounting bracket (1) and two new mounting bracket bolts (2) to the fuel rail clamp. Hand-tighten the mounting bracket bolts all the way until the bracket and bolts are flush. Do not torque at this time.

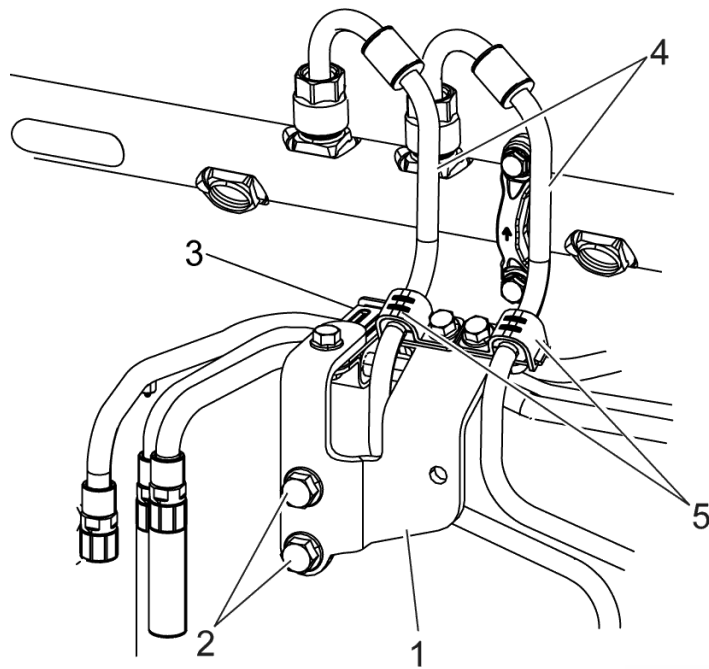

d470099b

NOTE: New P-clips (2) MUST be installed perpendicular to the bracket (1) and parallel with each other. Hold P-clips in place during tightening to avoid rotation of the P-Clips; see graphic below.

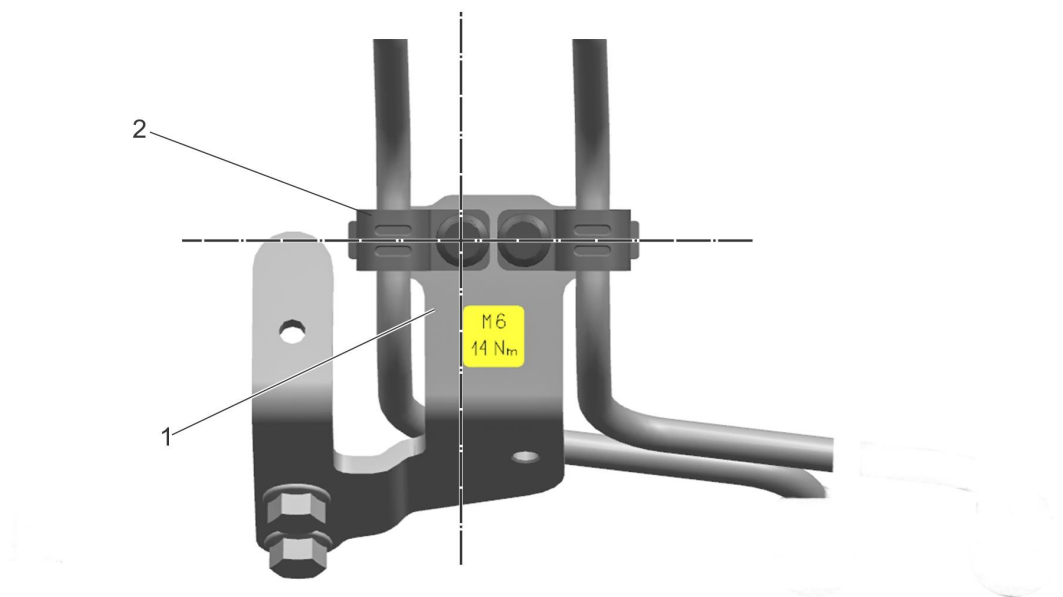

d470365

8. Ensure the rear high pressure fuel rail feed line is in place so that the p-clip mounting hole lines up with the bracket nut. No excessive force should be applied to any components in the high pressure fuel rail feed lines kit when assembling them loosely.
9. Install the new rear P-clip bolt hand tight. Do not torque at this time.
10. Hand-tighten the rear high pressure fuel rail feed line starting with the rail side nut first, and then the nut at the high pressure fuel pump.

NOTICE: After torquing each fuel line nut, P-clip bolt, mounting bracket bolt, and return line triple-clip bolt, mark the fittings and fasteners with a paint pen. Draw a line with the paint pen on the fitting or fastener and the adjacent metal as shown in the photograph below. The photograph shown below is of the KM63 fuel system, the three-filter fuel system is similar.

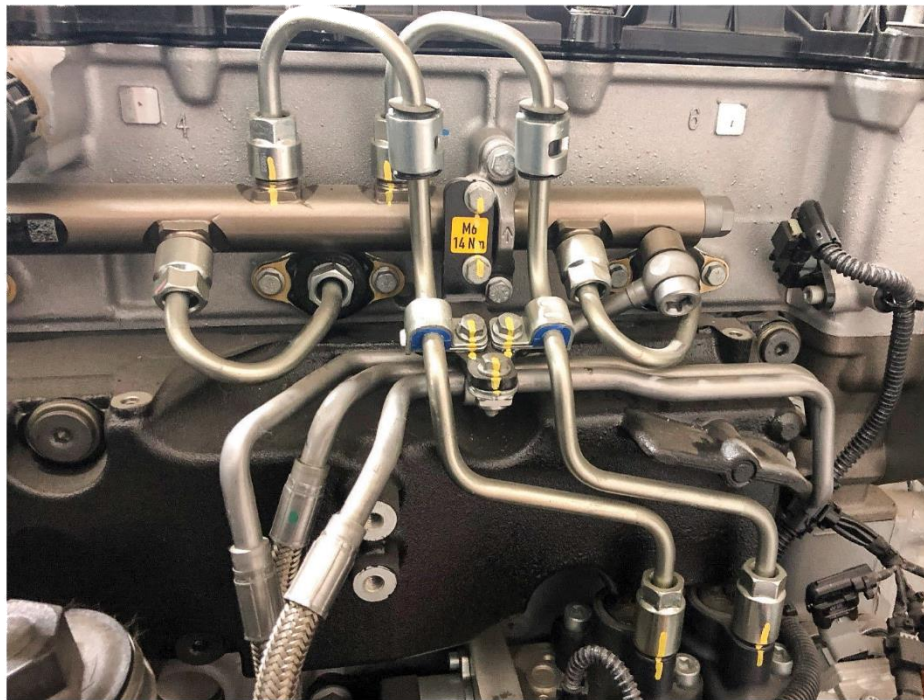

d070174



WARNING:

PERSONAL INJURY

All parts provided within this kit **MUST** be installed in the proper locations, and **MUST** be fastened to the specified torque. Failure to properly torque hardware/components will result in failure of a high pressure fuel feed line, resulting in possible fire and/or personal injury.

11. Using fuel line socket W314589010300 or a commercially available 19mm fuel line socket, torque the rear high pressure fuel rail feed line nuts to 40 N·m (30 lb·ft) starting with the rail side nut first, and then the nut at the high pressure fuel pump. Using a paint pen, draw a paint line on the torqued fuel line nut and the adjacent metal, as shown in the photograph above.
12. Ensure the front high pressure fuel rail feed line is in place so that the p-clip mounting hole lines up with the bracket nut. No excessive force should be applied to any components in the high pressure fuel rail feed lines kit when assembling them loosely.
13. Install the new front P-clip bolt hand tight. Do not torque at this time.
14. Hand-tighten the front high pressure fuel rail feed line starting with the rail side nut first, and then the nut at the high pressure fuel pump.
15. Using fuel line socket W314589010300 or a commercially available 19mm fuel line socket, torque the front high pressure fuel rail feed line nuts to 40 N·m (30 lb·ft) starting with the rail side nut first, and then the nut at the high pressure fuel pump. Using a paint pen, draw a paint line on the torqued fuel line nut and the adjacent metal, as shown in the photograph above.

NOTE: New P-clips (1) **MUST** be installed perpendicular to the bracket (2) and parallel with each other. Hold P-clips in place during tightening to avoid rotation of the P-Clips.

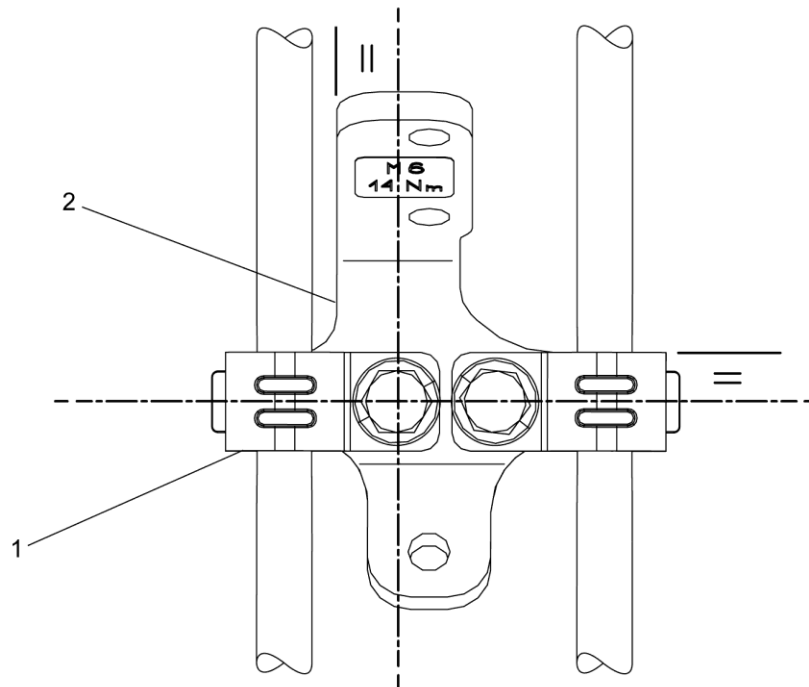

d470318

16. Torque the two new high pressure fuel rail feed line P-clip bolts to 14 N·m (124 lb·in.). Using a paint pen, draw a paint line on the torqued bolt head and the adjacent metal, as shown in the notice after step 10.
17. Torque the two new mounting bracket bolts to 30 N·m (22 lb·ft). Using a paint pen, draw a paint line on the torqued bolt head and the adjacent metal, as shown in the notice after step 10.
18. Install the bolt for the amplification, needle, and pressure limiting valve return line triple-clip (1). Torque to 14 N·m (124 lb·in.). Using a paint pen, draw a paint line on the torqued bolt head and the adjacent metal, as shown in the notice after step 10.
19. Inspect all components of the high pressure fuel rail feed line kit to make sure all fittings and fasteners have been properly installed, torqued and marked with a paint pen. Have the lead hand or supervisor review the installation and sign off on the repair order to ensure that all components were properly torqued and painted.
20. If removed for access, install the air cleaner. Refer to the Original Equipment Manufacturer (OEM) procedures.



CAUTION:

ELECTRICAL SHOCK

To avoid injury from electrical shock, use care when disconnecting battery cables. The magnetic switch studs are at battery voltage.

21. Connect the batteries.
22. Prime the fuel system. Refer to section "Priming the Fuel System - Three-Filter System".
23. Perform the Rail Pressure Bleed-Off test to verify that there are no leaks. Refer to section "Rail Pressure Bleed Off Test Using DiagnosticLink® Standard (EPA07 and EPA10) - Three-Filter Fuel System" .
24. If there are leaks, find the leak and repair, as necessary.
25. If necessary, install the bumper. Refer to the Original Equipment Manufacturer (OEM) procedures.
26. Close the hood.



13400 Outer Drive, West, Detroit, Michigan 48239-4001
Telephone: 313-592-5000
WWW.DEMANDDETROIT.COM

Specifications are subject to change without notice. Detroit Diesel Corporation is registered to ISO 9001:2008. Copyright © Detroit Diesel Corporation. All rights reserved. Detroit™ is a brand of Detroit Diesel Corporation, a Daimler company.

18SP729Rev. 1906 As technical advances continue, specifications will change. Printed in U.S.A.