



**DETROIT**<sup>™</sup>  
**DEMAND PERFORMANCE**<sup>™</sup>

**18SP726Rev –Two-Filter Fuel System KM59 GEN1  
DD13 High Pressure Fuel Feed Lines, Mounting Bracket  
and P-clips Service Kit  
(P/N: A0000701232)**



**WARNING:**

**PERSONAL INJURY**

All parts provided within this kit **MUST** be installed in the proper locations, and **MUST** be fastened to the specified torque. Failure to properly torque hardware/components will result in failure of a high pressure fuel feed line, resulting in possible fire and/or personal injury.



**WARNING:**

**PERSONAL INJURY**

All parts provided with this kit, and those they are replacing on the engine, function as a complete system and are single-use items. The old parts cannot be reused. Reusing parts or failing to use all new parts contained in the kit may result in the failure of high pressure fuel lines, possibly resulting in a fire.

**NOTICE:** Failure to follow these instructions will result in catastrophic damage to the engine and will not be covered under warranty.

**KIT DESCRIPTION**

This service kit includes all necessary parts to replace the high pressure fuel rail feed lines, mounting bracket, P-clips and mounting hardware in the event one of these parts are loosened, removed or missing from the engine.

**KIT CONTENTS**

Service kit P/N: A0000701232 contains all of the necessary parts to replace the high pressure fuel feed lines on KM59 Gen 1 DD13 engines.

<b>Part No.</b>	<b>Qty.</b>	<b>Description</b>
A4710780410	2	High pressure fuel feed line
A4720700540	2	P-Clip
N000000007957	2	Bolt M6x12mm
A4710701540	1	Mounting bracket
18SP726	1	Installation Instructions

# Removal of the High Pressure Fuel Rail Feed Lines - Two-Filter System

Remove as follows:

**NOTICE:** The high pressure fuel rail feed lines, vibration dampers, P-clips, mounting bracket and hardware are one-time use components and **MUST** be replaced any time they are removed or loosened. Refer to TS letter 16 TS-9 Rev2 (<http://dtna.info/16ts9>) for the high pressure fuel line kit numbers.

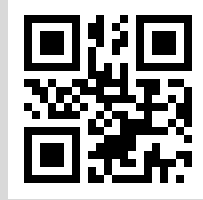

## **WARNING:**

### **PERSONAL INJURY**

To prevent the escape of high pressure fuel that can penetrate skin, ensure the engine has been shut down for a minimum of 10 minutes before servicing any component within the high pressure circuit. Residual high fuel pressure may be present within the circuit.

1. Shut off the engine, apply the parking brake, chock the wheels, and perform any other applicable safety steps.



## **CAUTION:**

### **ELECTRICAL SHOCK**

To avoid injury from electrical shock, use care when disconnecting battery cables. The magnetic switch studs are at battery voltage.

2. Disconnect the batteries.
3. Open the hood.
4. If necessary, remove the bumper. Refer to the Original Equipment Manufacturer (OEM) procedures.
5. If necessary for access, remove the air cleaner. Refer to the (OEM) procedures.

**NOTE:** Do not discard the return lines P-clip and bolt. It will be reused on the installation of the high pressure fuel rail feed lines.

6. Remove the return lines P-clip bolt (1) from the mounting bracket (2) and save for re-use. See graphic below.

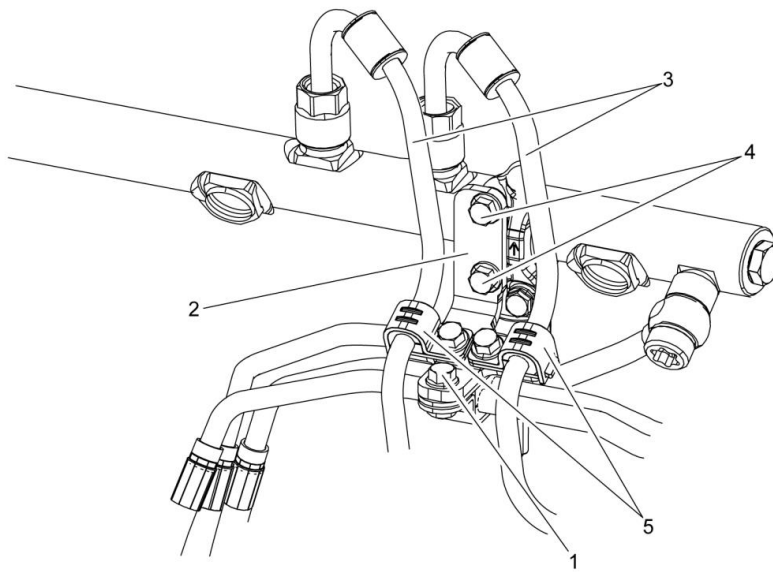

d470160c

Item	Component
1	Reused Return lines P-clip bolt
2	Mounting bracket
3	High pressure fuel feed lines
4	Mounting bracket bolts
5	P-clips and bolts

- Remove and discard the two P-clip bolts from the mounting bracket.

**NOTE:** For KM59 GEN1: When removing the high pressure fuel rail feed lines, hold the high pressure pump fitting with a 24mm wrench. If the high pressure pump fittings are loosened while removing the high pressure fuel rail feed lines, re-torque the fittings to 75 N·m (55 lb·ft).

- Remove and discard the high pressure fuel rail feed lines (3), P-clips (5), and vibration dampers as an assembly from the fuel rail and high pressure fuel pump. See graphic above.

# Installation of the High Pressure Fuel Rail Feed Lines - Two-Filter System

**NOTICE:** The high pressure fuel rail feed lines, vibration dampers, P-clips, mounting bracket and hardware are one-time use components and **MUST** be replaced any time they are removed or loosened. Refer to TS letter 16 TS-9 Rev2 (<http://dtna.info/16ts9>) for the high pressure fuel line kit numbers.



**NOTE:** DO NOT install bolts and fittings using power tools. All bolts and fittings **MUST** be installed using hand tools.



**WARNING:**

## **PERSONAL INJURY**

All hardware/components **MUST** be installed in the proper locations, and **MUST** be fastened to the specified torque. Failure to properly torque hardware/components will result in failure of a high pressure fuel feed line, resulting in possible fire and/or personal injury.

1. Clean the sealing area inside the high pressure fuel pump outlet fittings using a clean lint-free cloth.



d470166

2. Clean the sealing area inside the high pressure fuel rail using a clean lint-free cloth.



**NOTE:** Ensure triple clip is present with the top clip (1) inserted into the bottom clip (2) in position; see graphic below.

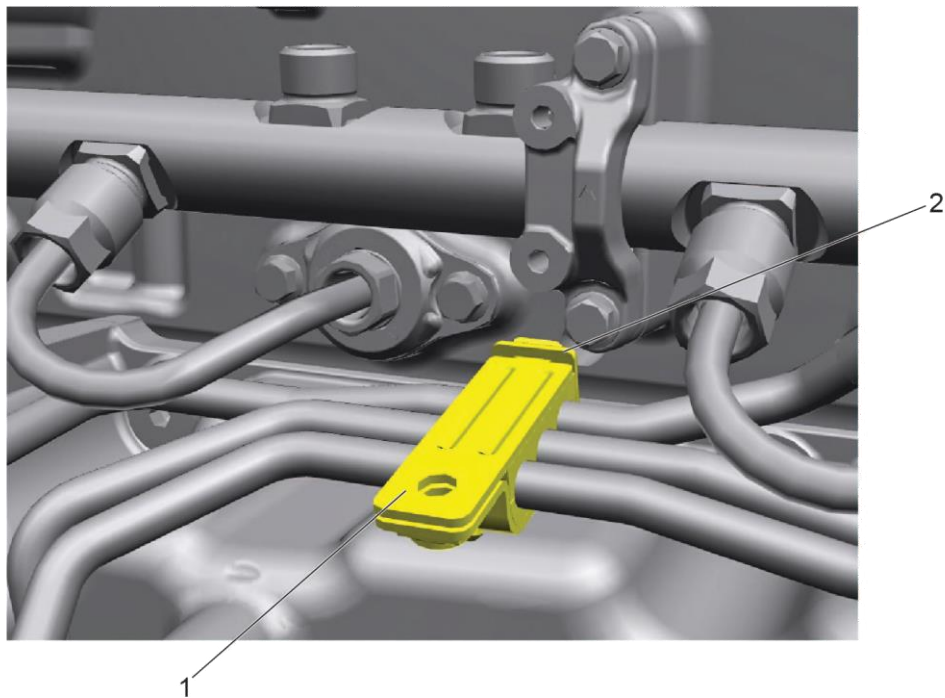

d470431

3. Install the new mounting bracket (2) and two new mounting bracket bolts (4) to the fuel rail clamp. Hand-tighten the mounting bracket bolts all the way until the bracket and bolts are flush. Do not torque at this time.

### KM59 GEN1 with Permanent Vibration Dampers

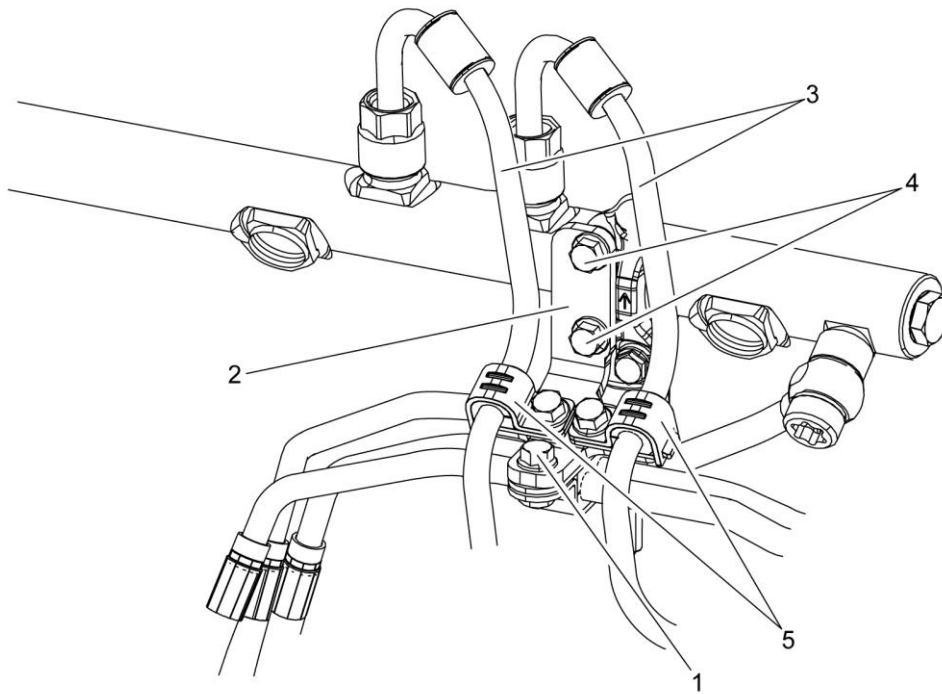

d470160c

**NOTICE:** New P-clip MUST be installed on to the high pressure fuel rail feed lines with the lower P-clip plate (1) inserted in to the P-clip window (2); see graphic below.

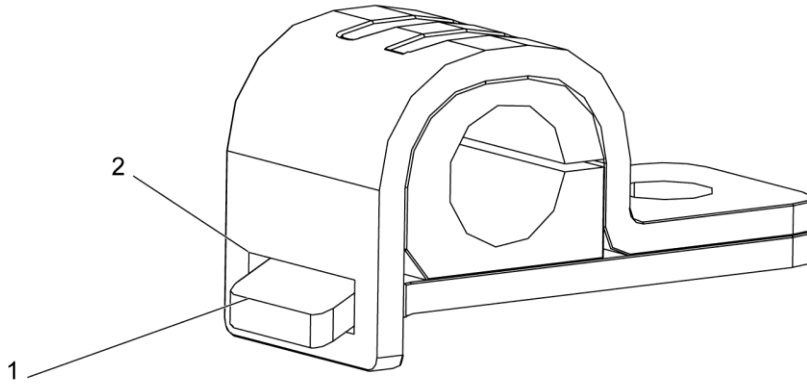

d470247

4. Install both of the new P-clips, one each, onto the high pressure fuel rail feed lines; see graphic below.

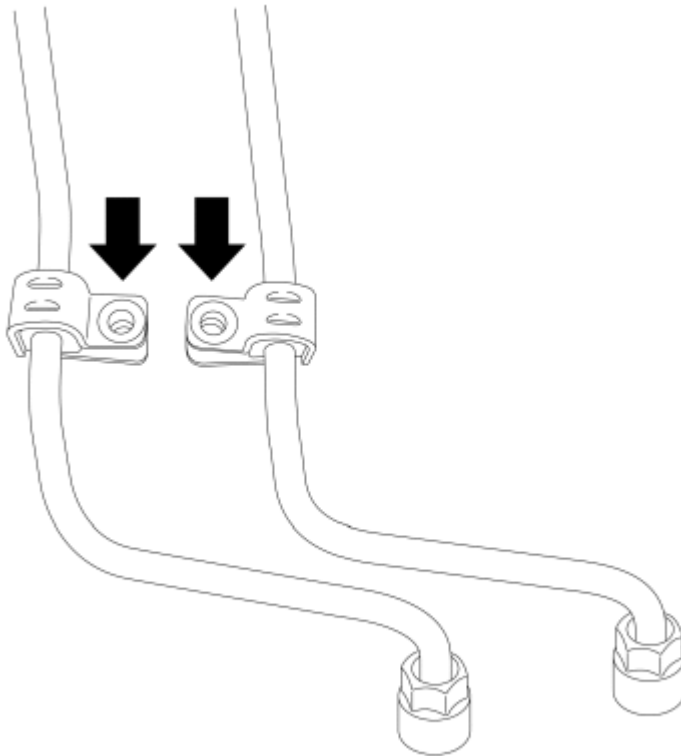

d470315

**NOTE:** DO NOT use new high pressure fuel rail feed lines that do not have new vibration dampers installed.

5. Position the rear high pressure fuel rail feed line into the fuel rail and the high pressure fuel pump. Do not start the threads of the fuel line nuts at this point.
6. Position the front high pressure fuel rail feed line into the fuel rail and the high pressure fuel pump. Do not start the threads of the fuel line nuts at this point.

**NOTE:** New P-clips (1) MUST be installed perpendicular to the bracket (2) and parallel with each other. Hold P-clips in place during tightening to avoid rotation of the P-Clips; see graphic below.

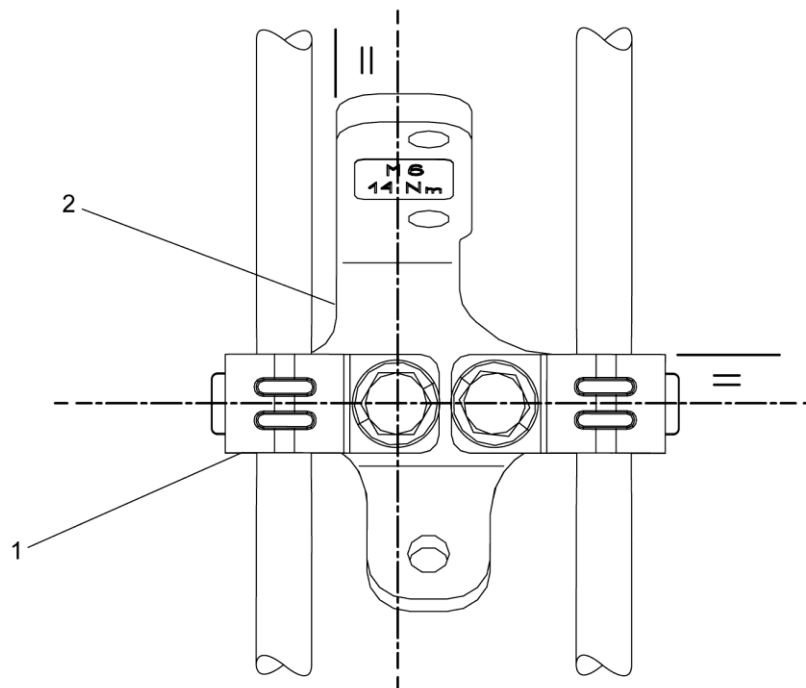

d470318

7. Ensure the rear high pressure fuel rail feed line is in place so that the p-clip mounting hole lines up with the bracket nut. No excessive force should be applied to any components in the high pressure fuel rail feed lines kit while loosely assembling them.
8. Install the new rear P-clip bolt hand tight. Do not torque at this time.
9. Hand-tighten the rear high pressure fuel rail feed line starting with the rail side nut first, and then the nut at the high pressure fuel pump.

**NOTICE:** After torquing each fuel line nut, P-clip bolt, mounting bracket bolt, and return line triple-clip bolt, mark the fittings and fasteners with a paint pen. Draw a paint line on the fitting or fastener and the adjacent metal as shown in the photograph below. The photograph shown below is of the KM63 fuel system, the KM59 fuel system is similar.

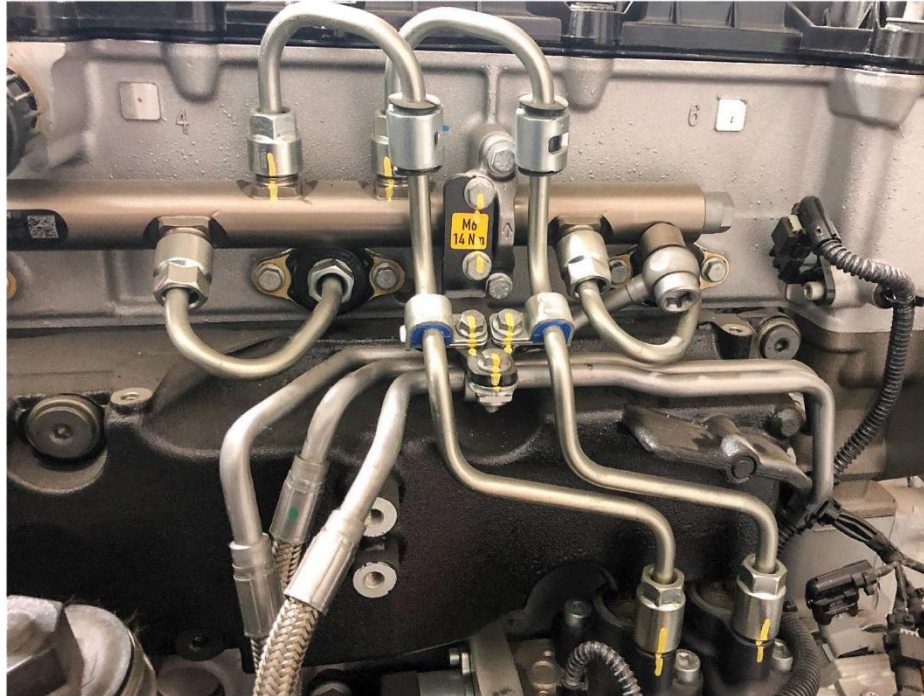

d070174

10. Using fuel line socket W314589010300 or a commercially available 19mm fuel line socket, torque the rear high pressure fuel rail feed line nuts to 40 N·m (30 lb·ft) starting with the rail side nut first, and then the nut at the high pressure fuel pump. Once torqued, use a paint pen to draw a line on the fuel line nut and the adjacent metal as shown in the photograph above.
11. Ensure the front high pressure fuel rail feed line is in place so that the p-clip mounting hole lines up with the bracket nut. No excessive force should be applied to any components in the high pressure fuel rail feed lines kit while loosely assembling them.
12. Install the new front P-clip bolt hand tight. Do not torque at this time.
13. Hand-tighten the front high pressure fuel rail feed line starting with the rail side nut first, and then the nut at the high pressure fuel pump.
14. Using fuel line socket W314589010300 or a commercially available 19mm fuel line socket, torque the front high pressure fuel rail feed line nuts to 40 N·m (30 lb·ft) starting with the rail side nut first, and then the nut at the high pressure fuel pump. Once torqued, use a paint pen to draw a line on the fuel line nut and the adjacent metal as shown in the photograph above.

**NOTE:** New P-clips (1) **MUST** be installed perpendicular to the bracket (2) and parallel with each other. Hold P-clips in place during tightening to avoid rotation of the P-Clips.

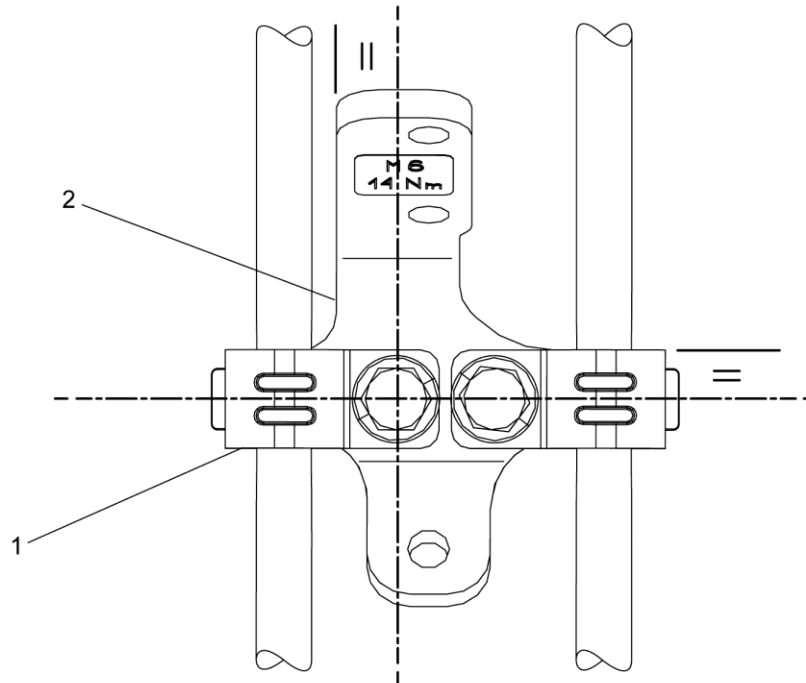

d470318



**WARNING:**

**PERSONAL INJURY**

All parts provided within this kit **MUST** be installed in the proper locations, and **MUST** be fastened to the specified torque. Failure to properly torque hardware/components will result in failure of a high pressure fuel rail feed line, resulting in possible fire and/or personal injury.

15. Torque the two new high pressure fuel rail feed line P-clip bolts to 14 N·m (124 lb·in.). Once torqued, use a paint pen to draw a paint line on the torqued bolt head and the adjacent metal, as shown in the notice after step 9.
16. Using a deep well socket for clearance, torque the two new mounting bracket bolts to 14 N·m (124 lb·in.). Once torqued, use a paint pen to draw a paint line on the torqued bolt head and the adjacent metal, as shown in the notice after step 9.
17. Install the bolt for the amplification, needle, and pressure limiting valve return line triple-clip (1). Torque to 14 N·m (124 lb·in.). Once torqued, use a paint pen to draw a paint line on the torqued bolt head and the adjacent metal, as shown in the notice after step 9.

18. Inspect all components of the high pressure fuel rail feed line kit to make sure all fittings and fasteners have been properly installed, torqued and marked with a paint pen. Have the lead hand or supervisor review the installation and sign off on the repair order to ensure that all components were properly torqued and painted.
19. If removed for clearance, install the air cleaner. Refer to the Original Equipment Manufacturer (OEM) procedures.



**CAUTION:**

**ELECTRICAL SHOCK**

To avoid injury from electrical shock, use care when disconnecting battery cables. The magnetic switch studs are at battery voltage.

20. Connect the batteries.
21. Prime the fuel system.  
Refer to section "Priming the Fuel System – KM59 GEN1 - Two-Filter System"
22. Perform the Rail Pressure Bleed-Off test to verify that there are no leaks.  
Refer to section "Rail Pressure Bleed Off Test Using DiagnosticLink® - Two-Filter Fuel System"
23. If there are leaks, find the leak and repair, as necessary.
24. If necessary, install the bumper. Refer to the Original Equipment Manufacturer (OEM) procedures.
25. Close the hood.



13400 Outer Drive, West, Detroit, Michigan 48239-4001  
Telephone: 313-592-5000  
[WWW.DEMANDETROIT.COM](http://WWW.DEMANDETROIT.COM)

---

Specifications are subject to change without notice. Detroit Diesel Corporation is registered to ISO 9001:2008. Copyright © Detroit Diesel Corporation. All rights reserved. Detroit™ is a brand of Detroit Diesel Corporation, a Daimler company.

**18SP726Rev. 1906** As technical advances continue, specifications will change. Printed in U.S.A.