

FLA COE
FLB COE
FLD Conventional
Business Class
FLC 112 Conventional

Century Class Conventional
Argosy COE
Cargo
Columbia
122SD and Coronado

Business Class M2
> Cascadia
108SD/114SD
New Cascadia

**Freightliner
Service Bulletin**

General Information

This procedure is to replace the white drip shield and secondary SAM cover on the SAM Cabin, with a new one-piece drip shield. This replacement would be a considerable product enhancement and would be a good modification when replacing any SAM Cabin.

Parts

Parts are available through PDCs. See [Table 1](#).

Parts	Description	Quantity
22-76215-000	Drip Shield	1

Table 1, Parts Required

Removal of SAM Cabin Drip Shields

1. Park the vehicle on a level surface, shut down the engine and set the parking brakes. Chock the tires.
2. Disconnect the battery.
3. Remove the glove box, refer to [Section 60.06](#) in the *Cascadia Workshop Manual* for instructions.
4. Remove the velcro fastened cover at the right side of the SAM Cab that holds the secondary cover in place.
5. Slowly pull the secondary cover out from the SAM Cab. See [Fig. 1](#).



Fig. 1, With Old Drip Shields Installed

6. Remove the old white drip shield from the SAM Cab. See [Fig. 2](#).

FLA COE
FLB COE
FLD Conventional
Business Class
FLC 112 Conventional

Century Class Conventional
Argosy COE
Cargo
Columbia
122SD and Coronado

Business Class M2
> Cascadia
108SD/114SD
New Cascadia



Fig. 2, Dash Support Studs

7. The new drip shield is designed to be installed with the SAM Cab removed, refer to [Section 54.01, Subject 100](#) in the *Cascadia Workshop Manual* for instructions.

Installation of New SAM Cabin Drip Shield

1. Gently compress and flex the new cover so it will fit through the Glovebox Opening. Line the holes in cover up with the existing dash support studs to seat cover. Tuck the leading edge of new cover into dash channel just above glove box opening.
2. Install and torque the new SAM Cab drip shield using two new M8 nuts with washers and tighten to 48 to 64 in.lbs (5.4 to 7.2 N.m). Use zip tie to secure the drip shield to dash support. See [Fig. 3](#) and [Fig. 4](#).

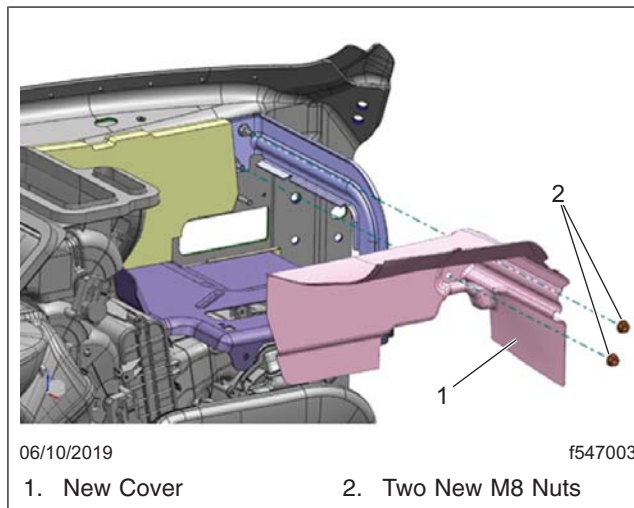

Fig. 3, New Cover Installed

FLA COE
FLB COE
FLD Conventional
Business Class
FLC 112 Conventional

Century Class Conventional
Argosy COE
Cargo
Columbia
122SD and Coronado

Business Class M2
> Cascadia
108SD/114SD
New Cascadia

Freightliner
Service Bulletin



Fig. 4, Tie Strap Attached

3. Install the SAM cab, refer to [Section 54.01, Subject 100](#) in the *Cascadia Workshop Manual* for instructions.
4. Reinstall the existing SAM cover shield. See. Make sure that any wiring is routed under this shield and does not interfere with the cover. See [Fig. 5](#).

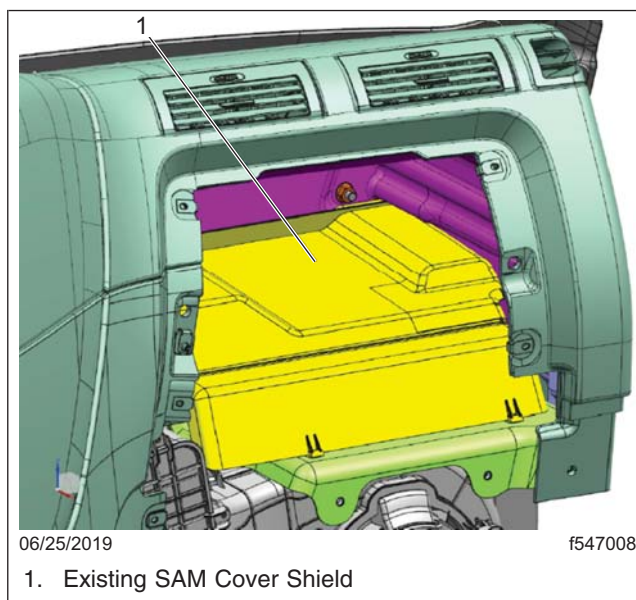

Fig. 5, Existing SAM Cover Shield Reinstalled

Note: Discard the white and small velcro cover.

5. Reconnect the batteries and remove the wheel chocks.

Freightliner Service Bulletin

FLA COE
FLB COE
FLD Conventional
Business Class
FLC 112 Conventional

Century Class Conventional
Argosy COE
Cargo
Columbia
122SD and Coronado

Business Class M2
> Cascadia
108SD/114SD
New Cascadia

Warranty

This bulletin is informational only. Warranty does not apply.