

ADDRESSEES	: Owners and operators of coaches listed under “Application” ABC Customer Care and Parts Source
VEHICLE MODEL	: TDX25US
MANUAL SECTION	: 08.14 Climate control – refrigerant system
BULLETIN TYPE	: Field Change Program
DATE	: July 16th, 2019
SUBJECT	: To check rating of lower-deck evaporator fans circuit-breakers
TERMS & CONDITIONS	: Refer to the warranty section further in this Bulletin.

APPLICATION:

The Field Change Program, subject of this bulletin, is applicable to TDX25US vehicles.

DESCRIPTION:

- On some of the above mentioned vehicles the evaporator fans located in the lower deck climate control unit are protected by four 15 Amp circuit breakers (Z027.1 up Z027.4). Field reports have determined that at very hot operating conditions these circuit breakers trip too fast.
- To prevent this from happening, Van Hool is conducting a field change program by which first the rating of these circuit breakers has to be checked and, if necessary, the circuit breakers have to be replaced by 20 Amp circuit breakers according to the step-by-step instructions given in this service bulletin.

MATERIAL:

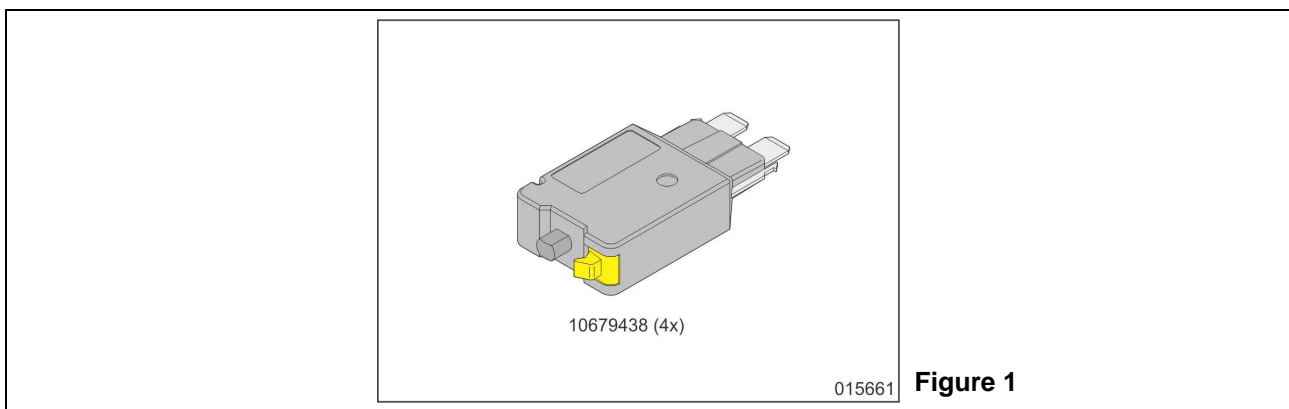

VH Reference	Description	Qty.
10679438	Circuit breaker, rating 20 Amp	4

Continued on next page

JOB REQUIREMENTS:

Job technician's qualifications/experience: electricity.

SPECIAL TOOLS, EQUIPMENT OR SERVICES:

This job requires no special tools, equipment or services.

PREPARATIONS:

- Park the coach on a level-surfaced service pit.
- Apply the parking brake and shut down the engine.
- Switch off all systems and turn off the battery master switch.
- Turn off the mechanical battery switch.
- Put a "DO NOT OPERATE" tag on the instrument panel.
- **Read the entire procedure before beginning to work.**



WARNING!

Observe safe shop practices at all times.

PROCEDURE:

Step	Action
1	Open junction box EK2 located above the engine, and accessible through the luggage compartment access door.
2	Check the rating of the circuit breakers Z27.1 up to and including Z27.4 protecting the evaporator fans located in the lower-deck climate control unit. Change, if necessary, the circuit breakers by the 20 Amp circuit breakers from the kit.
3	Notify ABC Companies by mail. Write the text "SB1650 completed for VIN....." in the mail and send the mail to warranty@abc-companies.com .
4	For ABC Companies only: register through the registration button located behind Service Bulletin SB1650 on the Van Hool customer portal. Write the text "SB1650 completed" in the field "Remark". Labor allowance will only be awarded after Van Hool has received the registration.

End of procedure.

WARRANTY:

1. Conditions

Van Hool accepts claims for this conversion as follows:

Compensation for labor hours: 15 minutes per vehicle

Campaign target date: Service Bulletin issue date + 0.5 year

2. Claim references:

- **Job code:** O61650V
- **Claim submission:** Contact ABC Customer Care Warranty Department for guidance.
- **Monitoring and performance:** The claim records pertaining to this Bulletin will be used to determine that the remedy has been executed in accordance with the manufacturer's instructions and to evaluate the status of this Field Change Program.

Continued on next page.

DISCLAIMER:

The procedures contained herein are not exclusive. Van Hool cannot possibly know, evaluate, or advise the transportation industry of all conceivable ways in which a procedure may be undertaken or of the possible consequences of each such procedure. Other procedures may be as good, or better, depending upon the particular circumstances involved. Each carrier who uses the procedures herein must first satisfy himself thoroughly that neither the safety of his employees or agents, nor the safety or usefulness of any products, will be jeopardized by any procedure selected.

INFORMATION HANDLING:

Important additions and modifications regarding technical information not yet included in the manual will be communicated through Service Bulletin.

VAN HOOL CUSTOMER PORTAL:

Consult the customer portal regularly for the latest service documentation. Beside the maintenance manual, you will also find the operating manual and the spare parts catalogue of your vehicle on the customer portal. The customer portal is accessible through www.vanhool.be, and only with a code (password) from Van Hool. If you do not have a password yet, request it by using the link on the Van Hool website.