



SI B01 01 19
Warranties

June 2019
Technical Service

G12 (N63R)/G30 (B58M) RADIATOR GRILL UPPER AND LOWER ACTIVE AIR FLAPS: LIMITED WARRANTY EXTENSION TO 10 YEARS/120,000 MILES

This Service Information bulletin supersedes SI B01 01 19 **dated April 2019**

What's New:

- The 2018 Model Year 530e iPerformance Sedans/530e xDrive iPerformance Sedans were added June 2019.
- Updated customer letter attached.



MODEL

G12 (750i Sedan) (N63R Engine) Model Year 2017 produced 6/14/2016 to 2/27/2017	G12 (750i xDrive Sedan) (N63R Engine) Model Year 2017 produced 6/14/2016 to 2/27/2017	G12 (ALPINA B7 xDrive) (N63R Engine) Model Year 2017 produced 6/14/2016 to 2/24/2017	G30 (540i Sedan) (B58M Engine) Model Year 2017 produced 7/8/2016 to 6/29/2017
G30 (540i xDrive Sedan) (B58M Engine) Model Year 2017 produced 9/8/2016 to 6/30/2017	G30 (530e iPerformance Sedan) (XB1H Engine) Model Year 2018 produced 2/27/2017 to 6/26/2018	G30 (530e xDrive iPerformance Sedan) (XB1H Engine) Model Year 2018 produced 11/10/2016 to 6/26/2018	



Note: The “Model” information above is for informational purposes only, it is not the only deciding factor.

The **2018 Model Year** 530e iPerformance Sedans/530e xDrive iPerformance Sedans were added June 2019.

ELIGIBLE VEHICLES

To assist you in identifying those vehicles that have this “component-specific” extended limited warranty coverage, the DCSnet Warranty Vehicle Inquiry has been updated with the VIN and Component-specific “Vehicle Comment” shown below:

Please see SI B01 01 19 (DC 51 64 90 01 00). For this vehicle, the Radiator Grill Upper and lower Active Air Flaps limited warranty for defects in materials or workmanship has been extended to 10 year/120,000 mile as determined from the original in-service date. This coverage is subject to the same vehicle eligibility requirements, limitations, and exclusions that apply to the BMW New Vehicle Limited Warranty for Passenger Cars and Light Trucks.

If you have ELW eligibility and/or coverage questions, please contact the Warranty department through IDS by selecting Coverage, Policy, Coding Questions and Mileage Corrections prior to performing any repair.



Note: Before performing a repair and submitting a claim, first confirm that the vehicle has the above “Notice of Limited Warranty Extension” in the DCSnet Warranty Inquiry “Vehicle Comments” section.

INFORMATION

For the eligible vehicles, BMW of North America, LLC (“BMW NA”) is extending the limited warranty for the vehicle’s **Radiator Grill Upper and Lower Active Air Flaps to:**

- **10 years/120,000 miles as determined by the vehicle’s original in-service date**

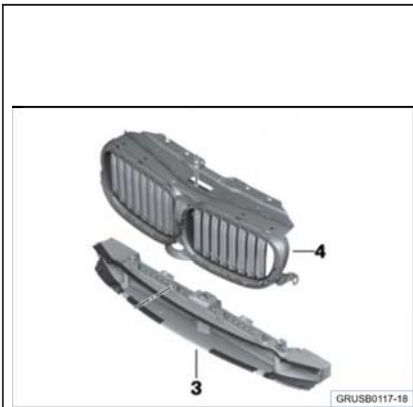

- This “component-specific” limited warranty extension applies to defects in materials or workmanship.
- This coverage is subject to the same vehicle eligibility requirements, limitations, and exclusions that apply to the BMW New Vehicle Limited Warranty for Passenger Cars and Light Trucks.
- Air flap issues caused by debris/blockage from outside influences is not a defect in materials or workmanship and is not claimable
- During the extended limited warranty coverage period (Eligible vehicles that are beyond the 4 year/50,000 mileage New Vehicle Limited Warranty coverage), Active Air Flap cosmetic defect issues are not covered.



Note: This bulletin is notice of a “limited warranty extension.” This is **NOT** a notice of a **Recall or Service Action.**

There is no immediate repair required unless the BMW vehicle is currently experiencing this problem.

Customer Notification Letter

Even though this is NOT a Recall, BMW NA will be sending VIN-specific customer notification letters.

SITUATION

A check engine light or check control message is present, and one or more of the following faults may be stored for the active air flaps behind the kidney grills:

- 13820D- Active cooling-air-flap control (AKKS), above: Driver, malfunction
- 138204 - Active cooling-air-flap control (AKKS), below: Deviation at all ambient temperatures
- 138203 - Active cooling-air-flap control (AKKS), below: Deviation in warm ambient temperature
- 21B043 - Active cooling-air-flap control (AKKS), above: Blockade in all ambient temperature
- 138207 - Active cooling-air-flap control (AKKS), above: Blockade in warm ambient temperature
- 138206 - Active cooling-air-flap control (AKKS), below: Blockade in warm ambient temperature
- 21B042 - Active cooling-air-flap control (AKKS), below: Blockade in all ambient temperature

The potential component-related causes of these faults are a:

1. Mechanical issue with the linkage of the upper or lower active air flap; and/or an
2. Internal short circuit of the adjustment motor.

CORRECTION

Determine the vehicles current i-Level using ISTA, AIR or the vehicle key read information.

Is the vehicle I-Level S15A-16-07-5xx or higher?

- **Yes:** Replace **ONLY the active air flap that has a fault stored**. If faults are stored for both active air flaps, replace both active air flaps. Follow ISTA test plan recommendations.
- **No:** If one flap is found to be faulty, **replace BOTH the upper and lower active air flaps together**.

Also refer to [SI B17 06 18](#) for additional information.

PARTS INFORMATION



Note: Please refer to the Electronic Parts Catalog (ETK/EPC), using the customer's VIN to locate

the applicable replacement part numbers.

- Only order these **parts in the quantities needed** to address customers' vehicles that have confirmed failures.
- **“Only in conjunction with” parts:** When applicable, if ETK/EPC item identifies additional part(s) that must also be replaced/installed “in-conjunction” with performing a covered repair, these “required” additional items are also covered under the terms of this extended limited warranty.
- Also refer to ETK/EPC and the repair instructions for onetime-use fasteners/screws and other information regarding repair-related gaskets, seals, fluid and/or lubricants that also need to be replaced/used and claimed.

WARRANTY INFORMATION

This component-specific limited warranty extension to 10 years/120,000 miles applies to “eligible US-specification BMW vehicles” that are registered, operated and have their covered repair performed by an authorized BMW center in the United States (including Puerto Rico) for defects in materials or workmanship.

Active cooling damper control-related fault codes/repairs that are caused by debris/blockage from outside influences is not a defect in materials or workmanship and is not claimable.

During the extended limited warranty coverage period (Eligible vehicles that are beyond the 4 year/50,000 mileage New Vehicle Limited Warranty coverage), Active Air Flap cosmetic defect issues are not covered.

The existing limited warranty coverage for the whole vehicle and other components has not changed.

This coverage supersedes the coverage that is provided under the BMW Certified Pre-Owned Program or any BMW Group Vehicle Service Contract that applies to the vehicle.

Should this component fail again, it is covered by the remaining portion of the extended limited warranty coverage period.

Non-Qualifying Repairs

Non-US specification vehicles, ineligible vehicles, eligible vehicles operated and repaired outside the United States and Puerto Rico and/or the diagnosis and repair of other unrelated issues are not covered under the terms of this limited warranty extension.

Qualifying Repairs - Claim Submission

Claim this work with the defect code and labor operations provided below.

Defect Code:	5164900100	 G12 N63 G30 B58 XH1B air flap control system
Labor Operation:	Labor Allowance:	Description:
00 00 006	Refer to AIR	Performing "vehicle test" (with vehicle diagnosis system – checking faults) (Main work)
Or:		
00 00 556	Refer to AIR	Performing "vehicle test" (with vehicle diagnosis system – checking faults) (Plus work)
And:		
61 21 528	Refer to AIR	Connect an approved battery charger/power supply (indicated in AIR as "Charging battery")

If you are using a Main labor code for another repair, use the Plus code labor operation 00 00 556 instead 00 00 006

And, additionally for the:

e-Vehicles

Labor Operation:	Labor Allowance:	Description:
61 25 910	Refer to AIR	Recharging high-voltage battery unit (to high voltage charging socket)

And, as necessary:

Labor Operation:	Labor Allowance:	Description:
61 00 006	Work time (WT)	Performing vehicle diagnosis – test module

Work time labor operation code 61 00 006 is not considered a Main labor operation; however, it does require an individual punch time and an explanation on the repair order and in the claim comments section.

And, if the:

Vehicle i-Level is lower than S15A-16-07-5xx (Replace Top and Bottom)

Labor Operation:	Labor Allowance:	Description:
51 64 715	Refer to AIR	Replacing top and bottom air flap control (after vehicle diagnosis)

Or, if the:

Vehicle i-Level is S15A-16-07-5xx or Higher (Replace based on the faults stored)

		Description:
--	--	---------------------

Labor Operation:	Labor Allowance:	
51 64 700	Refer to AIR	Replacing top flap control (after vehicle diagnosis)
Or:		
51 64 705	Refer to AIR	Replacing bottom flap control (after vehicle diagnosis)
Or:		
51 64 715	Refer to AIR	Replacing top and bottom air flap control (after vehicle diagnosis)

Refer to AIR for the corresponding flat rate unit (FRU) allowances for the above.

Or, for:

G12 (ALPINA Model only), based on the current Vehicle i-Level-related Repair Procedure

Labor Operation:	Labor Allowance:	Description:
51 00 001	14 FRU	Work time for replacing top flap control (after vehicle diagnosis)
Or:		
51 00 001	11 FRU	Work time for replacing bottom flap control (after vehicle diagnosis)
Or:		
51 00 001	15 FRU	Work time for replacing top and bottom air flap control (after vehicle diagnosis)

Work time labor operation code 51 00 001 is not considered a Main labor operation. Also, since the “work time” FRU allowance to be claimed is specified, a separate punch time is not required. However, it still requires an explanation on the repair order and in the claim comments section.

Previous Customer-pay Repairs – Limited Warranty Extension Reimbursement

Under this extended limited warranty, BMW of North America, LLC (“BMW NA”) will provide reimbursement for “qualifying customer-pay repairs” that were performed on an eligible vehicle prior to the release of this component-specific limited warranty extension.

Note: The **2018 Model Year** 530e iPerformance Sedans/530e xDrive iPerformance Sedans were added June 2019.

Customer-pay repairs are subject to the same vehicle eligibility requirements, limitations, and exclusions that apply to the BMW New Vehicle Limited Warranty for Passenger Cars and Light Trucks.

Repairs that do not qualify for Reimbursement

Repairs performed on ineligible vehicles, eligible vehicles operated and repaired outside the United States and Puerto Rico and/or the diagnosis and repair of other unrelated issues. This exclusion also applies to repairs that were performed using (including those repairs that result from using) non-genuine BMW parts and/or used BMW passenger car or light truck parts.

Requesting Reimbursement for a Previous Repair that Qualifies

For a customer to request reimbursement for a “qualifying customer-pay repair” performed either by an authorized BMW center or independent repair shop located in the United States (including Puerto Rico),

please have him/her submit his/her reimbursement request "online" at www.BMW-RP.com under the following reference:

- **B-ELWR 2019 Radiator Grill Air Flaps 10Y120M**

Reimbursement Request Procedure

The online process is initiated by attaching/sending "PDF files" of the supporting documentation for the "prior repair."

The letter also includes alternative methods to request reimbursement, either through the mail or by fax as described below:

BMW Customer Reimbursement Center

Attention: B-ELWR 2019 Radiator Grill Air Flaps 10Y120M

P.O. Box 561089

Dallas, Texas 75356

Fax number: 877-434-2992 

Please allow 4-6 weeks for processing your request.

Should you have any questions concerning this reimbursement process, please call 1-844-857-0341 .

BMW Owner/Operator Inquiries and Assistance

For all other questions, please contact the BMW's Customer Relations and Services via email at Customerrelations@bmwusa.com or via telephone at 1-800-831-1117 .

ATTACHMENTS

View PDF attachment [B010119 Customer Letter \(Draft\)](#).

[Copyright ©2019 BMW of North America, Inc.]

Month Year

This **“Important Limited Warranty Information”** applies to the BMW vehicle with the Vehicle Identification Number (VIN) of **AAAAAAA1234567890**.

Dear BMW Owner/Lessee:

BMW is committed to delivering the ultimate in product satisfaction to our customers.

Towards that end, BMW is extending the limited warranty for the:

- **Radiator Grill Air/Vent Flap**

On the above-referenced vehicle to:

- **10 years/120,000 miles as determined by your vehicle’s original in-service date.**

This “component-specific” limited warranty extension applies to defects in materials or workmanship. This coverage is subject to the same vehicle eligibility requirements, limitations, and exclusions that apply to the BMW New Vehicle Limited Warranty for Passenger Cars and Light Trucks.

This is notice of a “limited warranty extension.” This is not a notice of a Recall or Service Action.

If a repair to this component is required, please contact your nearest authorized BMW center in the United States or Puerto Rico to schedule an appointment. Your authorized BMW center will determine the vehicle’s eligibility and review the scope of repairs that are covered by this component-specific limited warranty extension.

After vehicle inspection and diagnosis, eligible repair work will be performed by the authorized BMW center in the United States (including Puerto Rico) free of charge.

Repairs performed on ineligible vehicles, eligible vehicles operated and repaired outside the United States and Puerto Rico and/or the diagnosis and repair of other unrelated issues are not covered by this limited warranty extension. This exclusion applies to repairs, including consequential, that were performed using non-genuine BMW parts and/or used passenger car or light truck parts.

The integrity of our products is essential to BMW’s success and our customers’ trust. We are determined to exceed your expectations and hope this warranty extension further enhances your ownership experience.

Sincerely,

BMW of North America, LLC

Previous Customer-pay Repairs – Limited Warranty Extension Reimbursement

BMW of North America, LLC

Month 20XX

VIN AAAAAAA1234567890

Under this extended limited warranty, BMW of North America, LLC (“BMW NA”) will provide reimbursement for “qualifying customer-pay repairs” that were performed on an eligible vehicle **prior** to the release of this component-specific limited warranty extension.

Customer-pay repairs are subject to the applicable vehicle and coverage eligibility requirements, exclusions and limitations that apply to the BMW New Vehicle Limited Warranty for Passenger Cars and Light Trucks.

Repairs that do not Qualify for Reimbursement

Repairs performed on ineligible vehicles, eligible vehicles operated and repaired outside the United States and Puerto Rico and/or the diagnosis and repair of other unrelated issues. This exclusion applies to repairs, including consequential, that were performed using non-genuine BMW parts and/or used passenger car or light truck parts.

Requesting Reimbursement for a Previous Repair that Qualifies

If you previously had a “qualifying customer-pay repair” performed either by an authorized BMW center or independent repair shop located in the United States (including Puerto Rico), please submit your reimbursement request “online” at www.BMW-RP.com under the following reference:

Covered Component Code

B-ELWR 2019 RADIATOR GRILL AIR FLAP 10Y120M

To initiate the online process, you will be asked to attach PDF files of the required documentation as outlined in the reimbursement checklist on the next page.

Alternative Method to Request Reimbursement

Alternatively, you may mail or fax your request and documentation to:

BMW Customer Reimbursement Center
Attention: B-ELWR 2019 RADIATOR GRILL AIR FLAP 10Y120M
P.O. Box 561089
Dallas, TX 75356
Fax number: 877-434-2992

Please allow 4-6 weeks for processing your request.

Should you have any questions concerning this reimbursement process, please call 1-844-857-0341.

For all other questions, please contact BMW’s Customer Relations and Services via email at Customerrelations@bmwusa.com or via telephone at 1-800-831-1117.

Please have your 17-character Vehicle Identification Number (VIN) available and include the VIN with all communications.

RADIATOR GRILL AIR FLAP: Limited Warranty Extension to 10 Years/120,000 Miles

Previous Customer-pay Repair Reimbursement – Documentation Checklist

BMW of North America, LLC

Reimbursement is available to the BMW Owner/Lessee who incurred the expense.

When submitting a reimbursement for a previous repair, please provide **legible copies** of the following documentation and include your VIN, name, address and your preferred contact telephone number(s):

Repair Order (RO) or Invoice

This document should include the following information:

- Customer name and address
- Vehicle Identification Number (“VIN”)
- The date of repair
- The mileage when the repair was performed
- Itemized breakdown of the labor charges for all repairs* including diagnosis
- Itemized breakdown of the parts, including any miscellaneous items, billed for all repairs*

*For repair orders containing multiple repair line items, only the specific line item expenses that relate to the component that is covered by this extended limited warranty will be considered for reimbursement.

Proof of Payment

Please provide a copy of at least **one** of the following items as valid proof of payment:

- Repair order (RO)/invoice stamped and dated as “PAID”
- Copy of a cancelled check
- Copy of a signed credit/debit card receipt
- Copy of a credit/debit card statement

Determining if an eligible vehicle’s repair qualifies for reimbursement:

Please use the following questions to review your repair order documentation prior to submitting a reimbursement request:

1. Why was the vehicle brought into the repair facility?
2. What was the repair facility's diagnosis?
3. What did the repair facility do to correct the concern and does it qualify?