

H OWNER'S MANUAL

LC Auxiliary Lift Axle Control Kits

SUBJECT: Installation Procedures

LIT NO: OM-H817

DATE: April 2019

REVISION: A

TABLE OF CONTENTS

Section 1	Introduction	2	Section 5	Plumbing & Wiring Diagram	13
Section 2	Product Description	2	Section 6	Suspension Operation	14
Section 3	Important Safety Notice	5	Section 7	Replacement Parts List	15
Section 4	Installation		Section 8	Frequently Asked Questions	18
	Installation Tips	9	Section 9	Troubleshooting Guide	19
	Master Control and Slave Assembly	9			
	Pneumatic Components	10			
	Electrical Components	11			

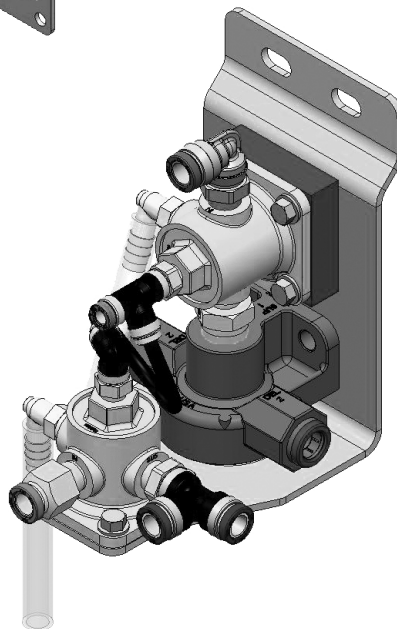
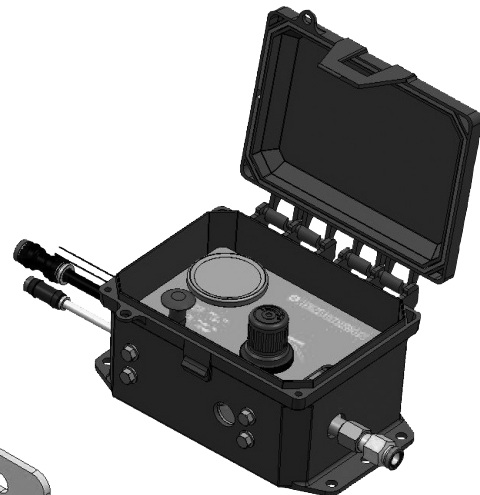
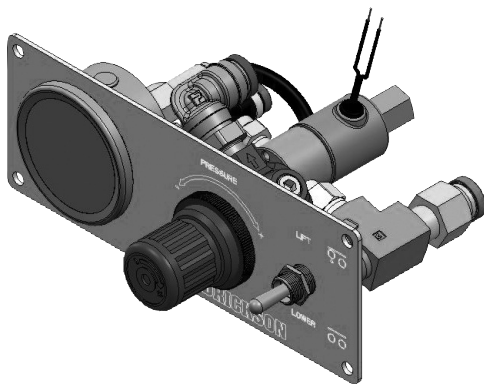



SECTION 1 Introduction

This publication is intended to acquaint and assist maintenance personnel with the installation, service, maintenance and operation of Hendrickson LC Auxiliary Lift Axle Control Kits on vehicles equipped with Hendrickson Auxiliary Suspensions.

NOTE Use only Hendrickson Genuine Parts for servicing this suspension system.

It is important to read and understand this entire publication prior to performing any installation, service, maintenance and operation of the product. The information in this publication contains product images, safety information, product specifications, features and proper installation, service and maintenance instructions for Hendrickson LC Auxiliary Lift Axle Control Kits.

Hendrickson reserves the right to make changes and improvements to its products and publications at any time. Contact Hendrickson Tech Services for information on the latest version of this manual at 1-800-660-2829 (toll-free U.S. and Canada), 1-740-929-5600 (Outside U.S. and Canada), or email: liftaxle@hendrickson-intl.com.

The latest revision of this publication is also available online at www.hendrickson-intl.com.

SECTION 2 Product Description

LC AUXILIARY LIFT AXLE CONTROL KITS are designed to accommodate a variety of lift axle applications and lift axle control requirements. One air kit is required per lift axle. **Standard LC control kits** are designed to lower the lift axle **to the down position** when the vehicle is powered off. **LC-MCA** and **MSO** kits are an alternative that are designed to lift the axle to the **up position** when the vehicle is powered off. Maryland has specific requirements that the **LC-MSO** was specifically designed to meet as well.

TABLE 2-1

AVAILABLE MODELS

	LIFT AXLE APPLICATION	INSIDE-MOUNTED	OUTSIDE-MOUNTED (COMPOSITE)	OUTSIDE-MOUNTED (STAINLESS)
* DOWN	Non-Steerable	LC-NSI	LC-UCO	LC-USO
	Steerable	LC-SSI		
	Reverse Lift & Lock	LC-LSI	LC-LCO	LC-LSO
	Reverse Down & Lock	LC-RSI	LC-RCO	LC-RSO
	Reverse Caster	LC-ASI	LC-ACO	LC-ASO
* UP	Non-Steerable		LC-MCA	
	Steerable			
	Non-Steerable (Maryland Spec)		LC-MSO	
	Steerable (Maryland Spec)			

NOTE: *Automatic position when the vehicle is powered off.



LC Auxiliary Lift Axle Control Kit Series designed for steerable axles include a **Solenoid Valve** that can be wired to provide lift in reverse functionality. Steerable axles must be lifted when moving in reverse or locked from turning to prevent damage to the axle / suspension. Steerable axles including a lock straight feature require additional components found in the kits from the Reverse Lift & Lock or Reverse Down & Lock rows of Table 2-1. Steerable axles designed to be able to reverse their caster angle and steer in reverse require additional components found in the kits from the Reverse Caster row of Table 2-1.

Outside-Mounted **LC Auxiliary Lift Axle Control Kit Series** also include an **Electric Override Switch**. The **Electric Override Switch** is intended to be installed in the cab to give drivers temporary override control without exiting the vehicle. When the override switch is powered **ON**, it will override the push / pull knob position on the master control to temporarily lift the axle from the cab. When the switch (or vehicle) is powered **OFF**, the axle will redeploy to match the state of the push / pull knob in the master control box. Lift in reverse functionality is maintained using the relay provided in the kit. Outside-Mounted lift axle controls are also offered in either a composite or stainless steel enclosure.

NOTE

State / Provincial law regulates the mounting location for the lift axle controls. Refer to the Department of Transportation requirements for the state that the vehicle will be operating in prior to selecting a control.

STANDARD COMPONENTS

All air kits come standard with one (1) master control assembly, one (1) slave assembly and one (1) pressure protection valve, for a single lift axle application. Reverse kits come with the previous components plus one (1) reverse control assembly.

FIGURE 2-1
Outside-Mounted Master
Control Assembly (Composite)

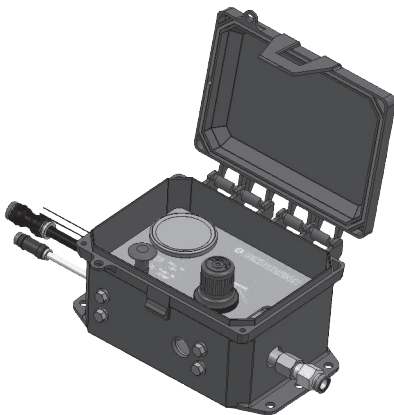

FIGURE 2-2
Outside-Mounted Master
Control Assembly (Stainless Steel)

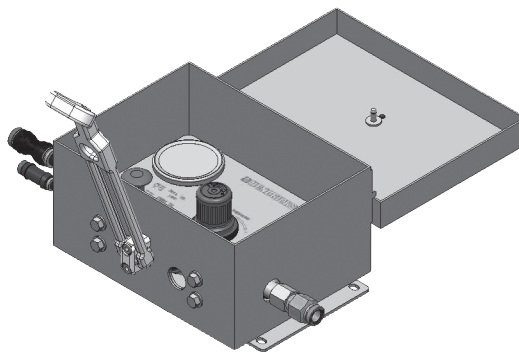

FIGURE 2-3
Slave Assembly

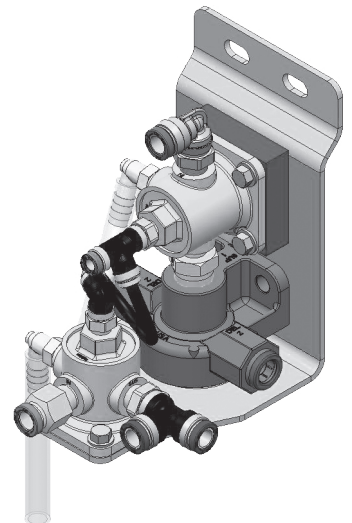

FIGURE 2-4
Inside-Mounted Master
Control Assembly

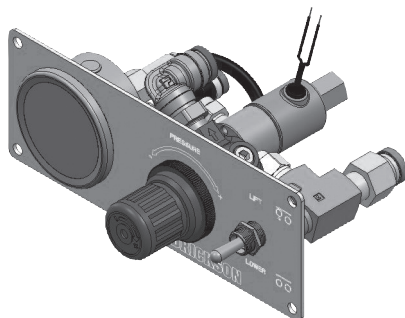
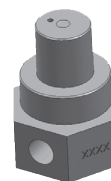

FIGURE 2-5
Pressure Protection Valve



OPTIONAL COMPONENTS

The following options will facilitate or enhance the installation and the operation of your air kit:

- **Brake Release Valve – Part No. R-001994**, A pilot valve used to allow auxiliary lift axle brakes to apply normally when the suspension is in the **DOWN** position. However, when the auxiliary lift axle is in the **UP** position, the brakes are released to eliminate hang-ups during high centering and to conserve system air pressure, see Figure 2-6.
- **Mounting Bracket** – A mounting bracket designed to accompany air kits, see Figures 2-7 to 2-9.

FIGURE 2-6
Brake Release Valve R-001994

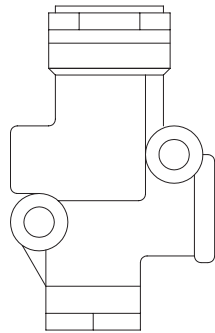

FIGURE 2-7
Single Panel Mount Bracket R-009800-1
For inside the cab

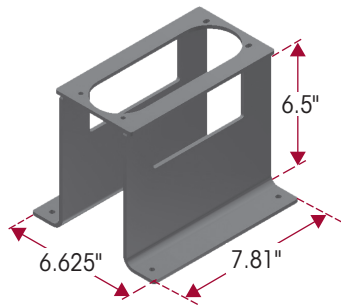

FIGURE 2-8
Double Panel Mount Bracket R-009800-2
For inside the cab

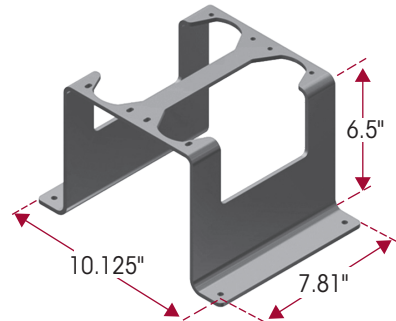
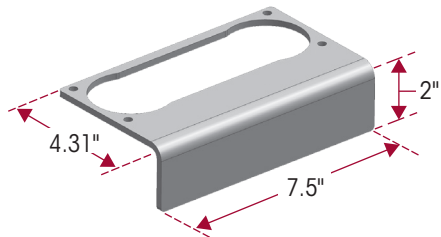

FIGURE 2-9
L-shape Panel Mount Bracket R-005771
For mounting the control panel on the side of the center console box
(Single Panel application only)



SECTION 3**Important Safety Notice**

Proper maintenance, service, and repair is important for the reliable operation of the suspension. The procedures recommended by Hendrickson and described in this technical publication are methods of performing such maintenance, service and repair.

All safety-related information should be read carefully to help prevent personal injury and to assure that proper methods are used. Improper servicing may damage the vehicle, cause personal injury, render it unsafe for operation, or void manufacturer's warranty.

Failure to follow the safety precautions in this manual can result in personal injury and / or property damage. Carefully read and understand all safety related information within this publication, on all decals and in all such materials provided by the vehicle manufacturer before conducting any maintenance, service or repair.

■ **EXPLANATION OF SIGNAL WORDS**

Hazard "Signal Words" (Danger-Warning-Caution) appear in various locations throughout this publication. Information accented by one of these signal words must be observed to help minimize the risk of personal injury to service personnel, or the possibility of improper service methods, which may damage the vehicle or render it unsafe.



This is the safety alert symbol. It is used to alert you to potential personal injury hazards. Obey all safety messages that follow this symbol to avoid possible injury or death.

Additional Notes or Service Hints are utilized to emphasize areas of procedural importance and provide suggestions for ease of repair. The following definitions indicate the use of these signal words as they appear throughout the publication.

DANGER

INDICATES AN IMMINENTLY HAZARDOUS SITUATION WHICH, IF NOT AVOIDED WILL RESULT IN SERIOUS INJURY OR DEATH.

WARNING

INDICATES A POTENTIAL HAZARDOUS SITUATION WHICH, IF NOT AVOIDED CAN RESULT IN SERIOUS INJURY OR DEATH.

CAUTION

INDICATES A POTENTIAL HAZARDOUS SITUATION WHICH, IF NOT AVOIDED MAY RESULT IN MINOR OR MODERATE INJURY.

NOTE

An operating procedure, practice condition, etc. which, is essential to emphasize.

SERVICE HINT

A helpful suggestion that will make the servicing being performed a little easier and / or faster.



The torque symbol alerts you to tighten fasteners to a specified torque value. Refer to Torque Specifications Section of this publication.

■ **SAFETY PRECAUTIONS**

WARNING

LIFT AXLE RAPID MOVEMENT

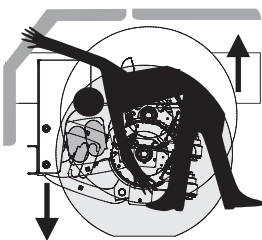

LIFT AXLE RAPID MOVEMENT CAN CAUSE SEVERE PERSONAL INJURY OR DEATH.

IF LIFT AXLE IS OPERATED BY AN AUTOMATIC OR SEMI-AUTOMATIC LIFT AXLE CONTROL SYSTEM, SUCH SYSTEM MAY CAUSE LIFT AXLE TO AUTOMATICALLY RAISE OR LOWER UNDER DIFFERENT CONDITIONS.

LIFT AXLE ACTIVATION AND MOVEMENT MAY VARY DEPENDING ON THE BRAND, CONFIGURATION, AND OPERATING CONDITION OF THE LIFT AXLE CONTROL SYSTEM AND / OR OTHER FACTORS. READ, UNDERSTAND, AND COMPLY WITH ALL APPLICABLE OPERATING INSTRUCTIONS AND SAFETY INFORMATION PROVIDED BY THE LIFT AXLE CONTROL SYSTEM MANUFACTURER AND VEHICLE MANUFACTURER.

ENSURE ALL PERSONNEL ARE CLEAR OF LIFT AXLE BEFORE AND DURING VEHICLE LOADING AND LIFT AXLE ACTIVATION UP OR DOWN.



CAUTION

LIFT AXLE ACTIVATION

DO NOT LOWER LIFT AXLE WHILE THE VEHICLE IS MOVING IN REVERSE OR TRAVELING AT MORE THAN 15 MPH. FAILURE TO DO SO CAN CAUSE COMPONENT DAMAGE.

CAUTION

REVERSE LOCKOUT OPERATION

DO NOT ACTUATE STEERABLE LIFT AXLE REVERSE LOCKOUT FEATURE (IF EQUIPPED) WHILE VEHICLE IS TURNING. FAILURE TO DO SO CAN CAUSE COMPONENT DAMAGE.

BEFORE TRAVELING IN REVERSE:

- ENSURE STEERABLE LIFT AXLE REVERSE LOCKOUT FEATURE (IF EQUIPPED) IS PROPERLY ACTUATED.
- RAISE ALL STEERABLE LIFT AXLES NOT EQUIPPED WITH REVERSE LOCKOUT FEATURE.

FAILURE TO DO SO CAN CAUSE COMPONENT DAMAGE.

CAUTION

REVERSE CASTER OPERATION

DO NOT LOWER STEERABLE LIFT AXLE EQUIPPED WITH REVERSE CASTER FEATURE WHILE VEHICLE IS MOVING IN REVERSE. FAILURE TO DO SO CAN CAUSE COMPONENT DAMAGE.

WARNING

LOAD CAPACITY

ADHERE TO THE PUBLISHED CAPACITY RATINGS FOR THE AUXILIARY AXLE. ADD-ON AXLE ATTACHMENTS (I.E. SLIDING FIFTH WHEELS) AND OTHER LOAD TRANSFERRING DEVICES CAN INCREASE THE AUXILIARY AXLE LOAD ABOVE THE RATED AND APPROVED CAPACITIES WHICH CAN RESULT IN FAILURE AND ADVERSE VEHICLE HANDLING, POSSIBLY CAUSING PERSONAL INJURY OR PROPERTY DAMAGE.

CAUTION

DAILY / PRE-TRIP OPERATOR INSPECTION

DAILY (AND BEFORE EACH TRIP) INSPECT ALL LIFT AXLE COMPONENTS FOR PROPER OPERATING CONDITION AND PROPER INSTALLATION TO THE TRUCK / TRAILER FRAME. THIS ESSENTIAL **DAILY / PRE-TRIP OPERATOR INSPECTION** MUST ALSO INCLUDE A VISUAL INSPECTION OF ALL WHEEL SEALS AND GASKETS FOR LEAKS, A VERIFICATION OF PROPER OIL LEVEL IN THE HUBS (IF APPLICABLE), INSPECTION OF ALL LIFT AND RIDE AIR-SPRINGS FOR WEAR, AND INSPECTION OF ALL TIRES FOR PROPER INFLATION AND ABNORMAL WEAR PATTERNS. IDENTIFY AND REPAIR / REPLACE ANY LOOSE, DAMAGED OR IMPROPERLY INSTALLED COMPONENTS. REFER TO THE CURRENT VERSION OF HENDRICKSON PUBLICATION NO. TP-H633 FOR ADDITIONAL SERVICE, REPAIR, AND REBUILD INSTRUCTIONS.

WARNING

REPAIR AND RECONDITIONING

THE REPAIR OR RECONDITIONING OF AUXILIARY AXLE COMPONENTS THAT ARE BENT, DAMAGED OR OUT OF SPECIFICATION IS NOT ALLOWED. ANY AXLE COMPONENTS FOUND TO BE DAMAGED OR OUT OF SPECIFICATION, MUST BE REPLACED. AXLE COMPONENTS CANNOT BE BENT, WELDED, HEATED, OR REPAIRED WITHOUT REDUCING THE STRENGTH OR LIFE OF THE COMPONENT. FAILURE TO FOLLOW THESE GUIDELINES CAN CAUSE ADVERSE VEHICLE HANDLING, POSSIBLE PERSONAL INJURY, DEATH, OR PROPERTY DAMAGE AND WILL VOID APPLICABLE WARRANTIES.

WARNING

PERSONAL PROTECTIVE EQUIPMENT

ALWAYS WEAR PROPER EYE PROTECTION AND OTHER REQUIRED PERSONAL PROTECTIVE EQUIPMENT TO HELP PREVENT PERSONAL INJURY WHEN YOU PERFORM VEHICLE MAINTENANCE, REPAIR OR SERVICE.

CAUTION

PROCEDURES AND TOOLS

A MECHANIC USING A SERVICE PROCEDURE OR TOOL, THAT HAS NOT BEEN RECOMMENDED BY HENDRICKSON, MUST FIRST SATISFY HIMSELF THAT NEITHER HIS SAFETY NOR THE VEHICLE'S SAFETY WILL BE JEOPARDIZED BY THE METHOD OR TOOL SELECTED. INDIVIDUALS DEVIATING IN ANY MANNER FROM THE INSTRUCTIONS PROVIDED ASSUME ALL RISKS OF POTENTIAL PERSONAL INJURY OR DAMAGE TO EQUIPMENT INVOLVED.

WARNING

IMPROPER JACKING METHOD

IMPROPER JACKING METHOD CAN CAUSE STRUCTURAL DAMAGE AND RESULT IN ADVERSE VEHICLE HANDLING, SEVERE PERSONAL INJURY OR DEATH. DO NOT USE AXLE BEAM OUTBOARD OF AXLE SPRING SEATS. REFER TO VEHICLE MANUFACTURER FOR PROPER JACKING INSTRUCTIONS.



WARNING

FASTENERS

DISCARD USED FASTENERS. ALWAYS USE NEW FASTENERS TO COMPLETE A REPAIR. FAILURE TO DO SO COULD RESULT IN FAILURE OF THE PART OR MATING COMPONENTS, ADVERSE VEHICLE HANDLING, PERSONAL INJURY, OR PROPERTY DAMAGE.

LOOSE OR OVER-TORQUED FASTENERS CAN CAUSE COMPONENT DAMAGE, ADVERSE VEHICLE HANDLING, PROPERTY DAMAGE, OR SEVERE PERSONAL INJURY. MAINTAIN CORRECT TORQUE VALUE AT ALL TIMES. CHECK TORQUE VALUES ON A REGULAR BASIS AS SPECIFIED, USING A REGULARLY CALIBRATED TORQUE WRENCH. TORQUE VALUES SPECIFIED IN THIS TECHNICAL PUBLICATION ARE FOR HENDRICKSON SUPPLIED FASTENERS ONLY. IF NON-HENDRICKSON FASTENERS ARE USED, FOLLOW TORQUE SPECIFICATIONS LISTED IN THE VEHICLE MANUFACTURER'S SERVICE MANUAL.

WARNING

MODIFYING COMPONENTS

DO NOT MODIFY OR REWORK PARTS WITHOUT AUTHORIZATION FROM HENDRICKSON. DO NOT SUBSTITUTE REPLACEMENT COMPONENTS NOT AUTHORIZED BY HENDRICKSON. USE OF MODIFIED, REWORKED, SUBSTITUTE OR REPLACEMENT PARTS NOT AUTHORIZED BY HENDRICKSON MAY NOT MEET HENDRICKSON'S SPECIFICATIONS, AND CAN RESULT IN FAILURE OF THE PART, ADVERSE VEHICLE HANDLING, POSSIBLE PERSONAL INJURY OR PROPERTY DAMAGE, AND WILL VOID APPLICABLE WARRANTIES. USE ONLY HENDRICKSON-AUTHORIZED REPLACEMENT PARTS.

THE VEHICLE MANUFACTURER SHOULD BE CONSULTED BEFORE MAKING ANY CHANGES TO THE VEHICLE'S FRAME. TYPICALLY, CUTTING OR ALTERING THE VEHICLE'S FRAME OR SIDE RAIL IS NOT PERMITTED AND MAY AFFECT THE MANUFACTURER'S WARRANTY COVERAGE.

ANY INSTALLATION DEVIATIONS MUST BE APPROVED IN WRITING BY HENDRICKSON'S PRODUCT ENGINEERING DEPARTMENT. FAILURE TO COMPLY WITH ANY OF THE ABOVE WILL VOID APPLICABLE WARRANTIES.

WARNING

DAMAGED AXLE COMPONENTS

IF A VEHICLE EQUIPPED WITH A HENDRICKSON AUXILIARY AXLE IS INVOLVED IN A CRASH, A THOROUGH INSPECTION OF THE AXLE MUST BE PERFORMED NOTING THE CONDITION OF THE AXLE BEAM, KINGPINS, AND KNUCKLE ASSEMBLIES, INCLUDING THE AREAS OF AXLE-TO-KINGPIN INTERFACE, FOR ANY DAMAGE, GAPS, KINGPIN MOVEMENT OR PLAY. IF ANY COMPONENT APPEARS DAMAGED, OR THE KINGPIN APPEARS TO CONTAIN ANY DAMAGE, GAPS, MOVEMENT OR PLAY, THE COMPLETE AXLE ASSEMBLY MUST BE REPLACED.

IN ADDITION, IN THE EVENT A CRASH RESULTS IN EXCESSIVE SIDE LOAD DAMAGE TO ADJACENT PARTS, SUCH AS A BENT WHEEL, HUB, OR SPINDLE, IT IS STRONGLY RECOMMENDED TO REPLACE SUCH ADJACENT PARTS AND THE COMPLETE AXLE ASSEMBLY.

CONTACT HENDRICKSON TECHNICAL SERVICES DEPARTMENT WITH ANY QUESTIONS. FAILURE TO REPLACE ANY DAMAGED COMPONENTS CAN CAUSE ADVERSE VEHICLE HANDLING, POSSIBLE PERSONAL INJURY, DEATH, OR PROPERTY DAMAGE AND WILL VOID ANY APPLICABLE WARRANTIES.

WARNING

SUPPORT THE VEHICLE PRIOR TO SERVICING

PLACE THE VEHICLE ON A LEVEL FLOOR AND CHOCK THE WHEELS TO HELP PREVENT THE VEHICLE FROM MOVING. PRIOR TO SERVICING A VEHICLE IN THE RAISED POSITION, PROPERLY SUPPORT THE VEHICLE WITH SAFETY STANDS. DO NOT WORK AROUND OR UNDER A RAISED VEHICLE SUPPORTED ONLY WITH FLOOR JACKS OR OTHER LIFTING DEVICES, FAILURE TO DO SO CAN CAUSE DEATH, PERSONAL INJURY OR DAMAGE TO COMPONENTS.

WARNING

SUPPORT THE LIFT AXLE PRIOR TO SERVICING

PLACE THE VEHICLE ON A LEVEL FLOOR AND CHOCK THE WHEELS TO HELP PREVENT THE VEHICLE FROM MOVING. PRIOR TO SERVICING A LIFT AXLE IN THE RAISED POSITION, (1) PROPERLY SUPPORT THE LIFT AXLE WITH SAFETY STANDS, AND (2) RELEASE ALL AIR PRESSURE IN THE LIFT AXLE AIR SPRINGS AND RIDE SPRINGS. DO NOT WORK AROUND OR UNDER A RAISED LIFT AXLE SUPPORTED ONLY WITH FLOOR JACKS OR OTHER LIFTING DEVICES. FAILURE TO DO SO CAN CAUSE DEATH, PERSONAL INJURY OR DAMAGE TO COMPONENTS.



⚠ WARNING

AIR SPRINGS

PRIOR TO AND DURING DEFLATION AND INFLATION OF THE AIR SUSPENSION SYSTEM, ENSURE THAT ALL PERSONNEL AND EQUIPMENT ARE CLEAR FROM UNDER THE VEHICLE AND AROUND THE SERVICE AREA. FAILURE TO DO SO CAN CAUSE SEVERE PERSONAL INJURY, DEATH, OR PROPERTY DAMAGE.

⚠ WARNING

AIR SPRINGS

EXHAUST ALL PRESSURE IN LIFT AXLE AIR SPRINGS AND VEHICLE AIR SYSTEM BEFORE WORKING ON OR AROUND LIFT AXLE. FAILURE TO DO SO CAN CAUSE SEVERE PERSONAL INJURY OR DEATH.

⚠ CAUTION

AIR SPRINGS

INFLATE THE SUSPENSION SLOWLY AND MAKE SURE THE RUBBER BLADDER OF THE AIR SPRING INFLATES UNIFORMLY AND IS NOT BINDING. FAILURE TO DO SO CAN CAUSE DAMAGE TO THE AIR SPRING AND / OR MOUNTING BRACKETS AND WILL VOID APPLICABLE WARRANTIES.

⚠ WARNING

AIR SPRINGS

AIR SPRING ASSEMBLIES MUST BE DEFLATED PRIOR TO LOOSENING ANY ADJACENT HARDWARE. UNRESTRICTED AIR SPRING ASSEMBLIES CAN VIOLENTLY SHIFT. DO NOT INFLATE AIR SPRING ASSEMBLIES WHEN THEY ARE UNRESTRICTED. AIR SPRING ASSEMBLIES MUST BE RESTRICTED BY SUSPENSION OR OTHER ADEQUATE STRUCTURE. DO NOT INFLATE BEYOND PRESSURES RECOMMENDED BY AIR SPRING MANUFACTURER. CONTACT HENDRICKSON TECHNICAL SERVICES FOR DETAILS. IMPROPER USE OR OVER INFLATION MAY CAUSE AIR SPRING ASSEMBLIES TO BURST, CAUSING PROPERTY DAMAGE AND / OR SEVERE PERSONAL INJURY.

⚠ WARNING

OFF ROADWAY TOWING

HENDRICKSON DOES NOT RECOMMEND TOWING A VEHICLE BY THE AUXILIARY AXLE. DOING SO WILL DAMAGE THE AXLE AND WILL VOID APPLICABLE WARRANTIES.

⚠ WARNING

PARTS CLEANING

SOLVENT CLEANERS CAN BE FLAMMABLE, POISONOUS, AND CAUSE BURNS. TO HELP AVOID SERIOUS PERSONAL INJURY, CAREFULLY FOLLOW THE MANUFACTURER'S PRODUCT INSTRUCTIONS AND GUIDELINES AND THE FOLLOWING PROCEDURES:

1. WEAR PROPER EYE PROTECTION.
2. WEAR CLOTHING THAT PROTECTS YOUR SKIN.
3. WORK IN A WELL VENTILATED AREA.
4. DO NOT USE GASOLINE OR SOLVENTS THAT CONTAIN GASOLINE. GASOLINE CAN EXPLODE.
5. HOT SOLUTION TANKS OR ALKALINE SOLUTIONS MUST BE USED CORRECTLY. FOLLOW THE MANUFACTURER'S RECOMMENDED INSTRUCTIONS AND GUIDELINES CAREFULLY TO HELP PREVENT PERSONAL ACCIDENT OR INJURY.

DO NOT USE HOT SOLUTION TANKS OR WATER AND ALKALINE SOLUTIONS TO CLEAN GROUND OR POLISHED PARTS. DOING SO WILL CAUSE DAMAGE TO THE PARTS AND VOID APPLICABLE WARRANTIES.

SECTION 4 Installation

INSTALLATION TIPS

1.	Use only air brake tubes that conform to S.A.E. J844 and ensure all tubing is free from kinks. Ensure that the minimum bend radii are achieved on all tubing prior to assembly.
2.	Recommended minimum bend radii: <ul style="list-style-type: none"> ■ ¼" Tube – 1.0 inch ■ ⅜" Tube – 1.5 inches
3.	Use only dedicated tube cutters when preparing tube ends for insertion into push-in fittings.
4.	Ensure tube ends are square, free from all damage, and clean.
5.	Ensure tube is fully inserted into fittings (tube ends are pushed past both the grip ring and the sealing O-ring).
6.	Ensure fitted panels have enough free length of tube to ensure the tube in the fittings is not under any tension.
7.	Ensure there is sufficient free electrical cable to prevent wires and connections from being under tension.
8.	Store electrical connection inside the enclosure (Outside-Mounted kits only).
9.	When installing the pressure protection valve, ensure to orient with the vent hole facing down.

MASTER CONTROL AND SLAVE ASSEMBLY

INSTALLATION

1. Refer to Figure 5-1 in the Plumbing and Wiring Diagram Section of this publication.
2. Install exhaust fittings and tubes (provided loose) onto slave assembly, see Figure 4-1.
3. Mount slave assembly to vehicle frame, locating near the lift axle for optimal plumbing.
4. Mount master control assembly in preferred location.

NOTE

If Controls are Inside-Mounted – Regulator panel nut is installed loosely by Hendrickson for ease of installation. Tighten once the master control is positioned in the mounting bracket.

FIGURE 4-1

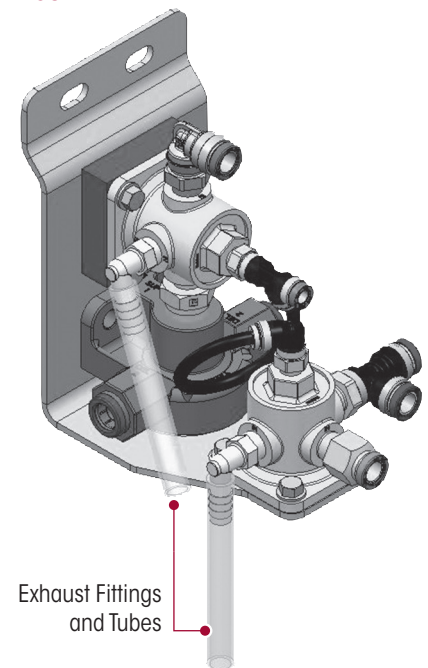

PNEUMATIC COMPONENTS

1. Route the airlines required for all kits, see Figures 4-2 and 4-3 for individual port locations.
 - a. Route airline from Supply Air Tank to **GREEN PORT** on master control and to **GREEN PORT** on slave assembly.
 - b. Install the pressure protection valve (R-017521-13) as shown in Figure 5-1.
 - c. Route airline from **PURPLE PORT** on master control to slave assembly for regulated airline.
 - d. Route airline from **BROWN PORT** on master control to slave assembly for piloted airline.
 - e. Route airline from **BLUE PORTS** on slave assembly to lift springs.
 - f. Route airline from **RED PORTS** on Quick-Exhaust Valve on slave assembly to ride springs.

**FIGURE 4-2
MASTER CONTROL**

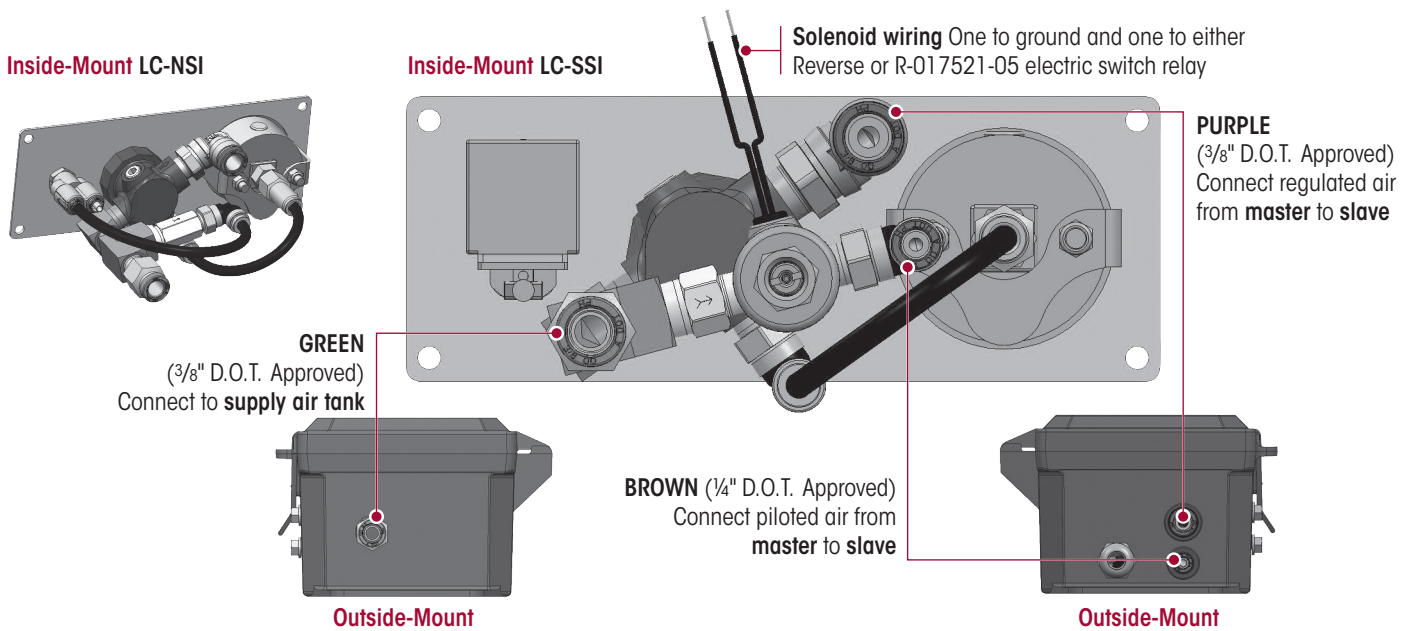

**FIGURE 4-3
SLAVE ASSEMBLY**

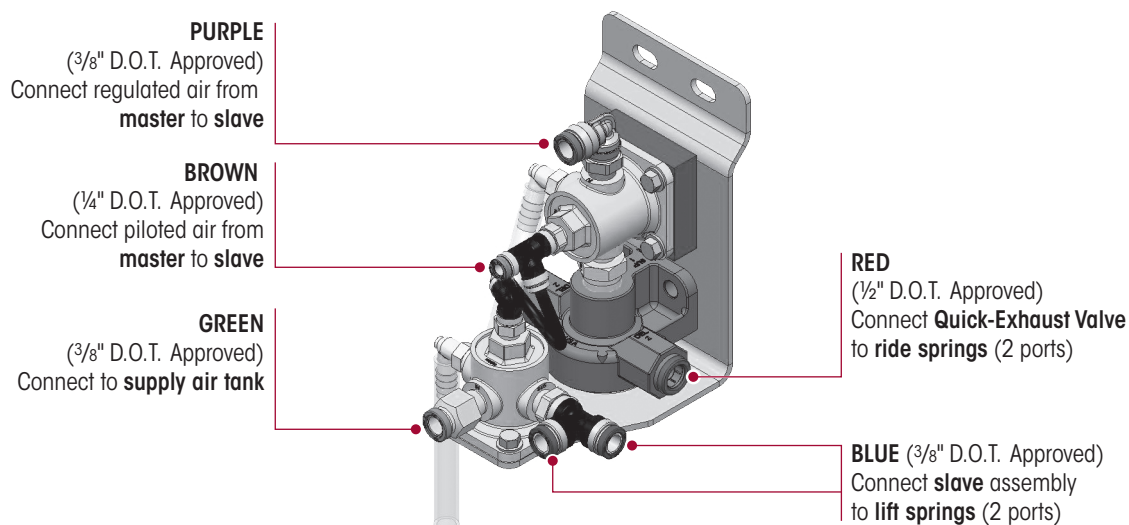



ELECTRICAL COMPONENTS

1. **If equipped with a Two-Wire Solenoid Valve** – connect one (1) lead to a good vehicle ground and the other to a good reverse signal such as the reverse light wiring. **DO NOT** connect solenoid to reverse signal if equipped with Electric Override Switch (R-017521-05), see Figure 4-4. Move on to the Step 2.
2. **If equipped with the Electric Override Switch** – refer to the Plumbing and Wiring Diagram in Section 5 and make the following connections, see Figure 4-4.

NOTE

If equipped with a **Non-Steerable** lift axle or an air control kit that lifts the axle to the up position when the vehicle is powered off, such as LC-MCA or LC-MSO, special wiring instructions are included.

- a. Connect **A** red wire from Relay Terminal 86 to a good reverse signal. For non-steerable lift axle applications, do not connect. Cap off this wire to avoid grounding.
 - b. Connect **B** white wire from Relay Terminal 30 to the open lift axle control solenoid wire.
 - c. Connect **C** red wire from Relay Terminal 87a to the toggle switch and another from the open toggle switch terminal to a +12v DC power source. An Ignition **Accessory On** power source is recommended.
 - d. Connect **D** black wire from Relay Terminal 85 to a good vehicle ground.
 - e. Connect **E** red wire from Relay Terminal 87 to a +12v DC power source. An Ignition **Accessory On** power source is recommended. For non-steerable lift axle applications **DO NOT** connect. Cap off this wire to avoid grounding. For air control kits that lift the axle to the up position when the vehicle is powered off including LC-MCA and LC-MSO **DO NOT** connect. Cap off this wire to avoid grounding.
3. **LC-LSI / LCO / LSO specific instruction:**
 - a. Find a position inside the frame or body to mount the Reverse Lift & Lock Valve (R-017519-00). Preferably near the lift axle.
 - b. Add a Tee in the Supply Line and route an airline to the **Reverse Lift & Lock (N.C. Port)**.
 - c. Add a Tee in the Master / Slave Pilot Line and route an airline to the **Reverse Lift & Lock (N.O. Port)**.
 - d. Route an airline from the **Reverse Lift & Lock (COM Port)** to the Lock Straight Chambers mounted on the axle using a Tee as necessary.
 4. **LC-RSI / RCO / RSO specific instruction:**
 - a. Find a position inside the frame or body to mount the Reverse Down & Lock Valve (R-017520-00), preferably near the lift axle.
 - b. Add a Tee in the Supply Line and route an airline to the **Reverse Down & Lock (IN Port)**.
 - c. Route an airline from the **Reverse Down & Lock (CYL Port)** to the Lock Straight Chambers mounted on the axle using a Tee as necessary.
 - d. Follow the diagram on Electric Override Switch, see Figure 4-4.
 5. **LC-ASI / ACO / ASO specific instruction:**
 - a. Find a position inside the frame or body to mount the Reverse Caster valve (R-017518-00). Preferably near the lift axle.
 - b. Add a Tee in the Supply Line and route an airline to the **Reverse Caster Valve (IN Port)**.
 - c. Add a Tee in the Lift Line and route an airline to the **Reverse Caster (PILOT Port)**.
 - d. Route an airline from the **Reverse Caster (COM Port)** to the Reverse Caster Chambers mounted on the suspension hanger using a Tee as necessary.
 - e. Follow the diagram on Electric Override Switch, see Figure 4-4.

FIGURE 4-4
ELECTRIC OVERRIDE SWITCH

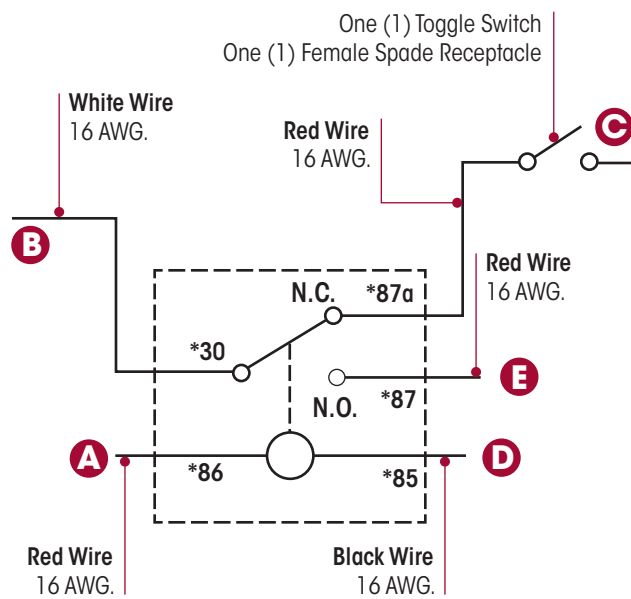

NOTE

* Relay Terminal

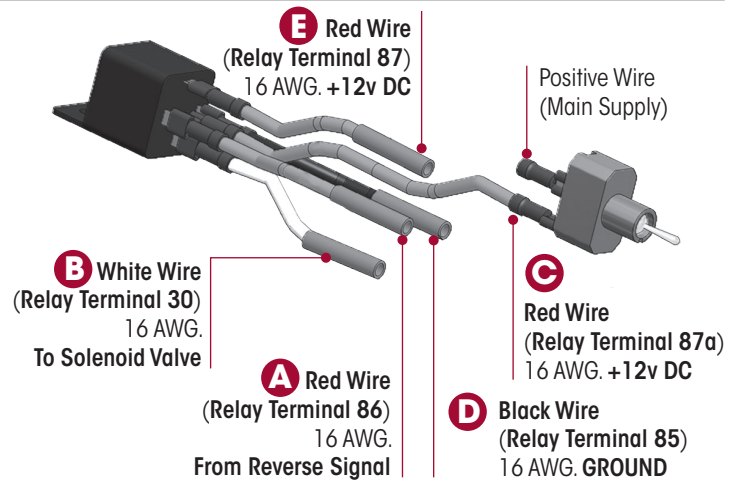

NOTES

1. Electric Override Switch is supplied with all Outside-Mounted air kits.
2. For LC-MCA and LC-MSO air kits, remove the red wire **E** and discard.
3. For non-steer, **DO NOT** connect wires **A** (Relay Terminal 86) or wire **E** (Relay Terminal 87). This disables lift in the reverse function but maintains the Lift Override function.

REVERSE CONTROLS

FIGURE 4-5
***Reverse Lift & Lock Assembly R-017519-00**

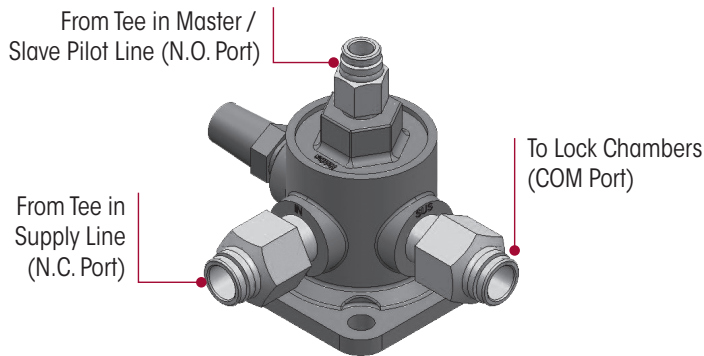

FIGURE 4-6
***Reverse Down & Lock Valve Assembly R-017520-00**

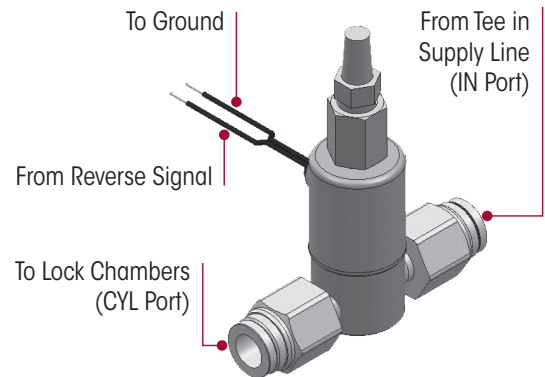
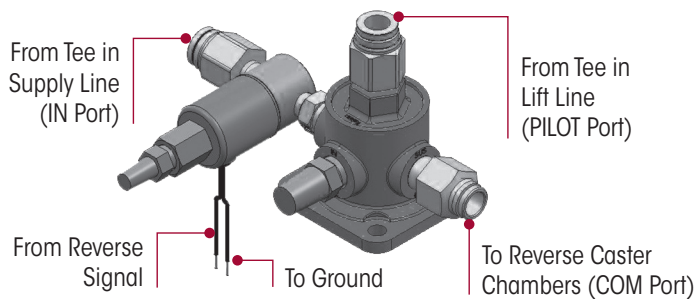

FIGURE 4-7
***Reverse Caster Assembly R-017518-00**



NOTE

*Orient filters downward

SECTION 5 Plumbing & Wiring Diagram

FIGURE 5-1

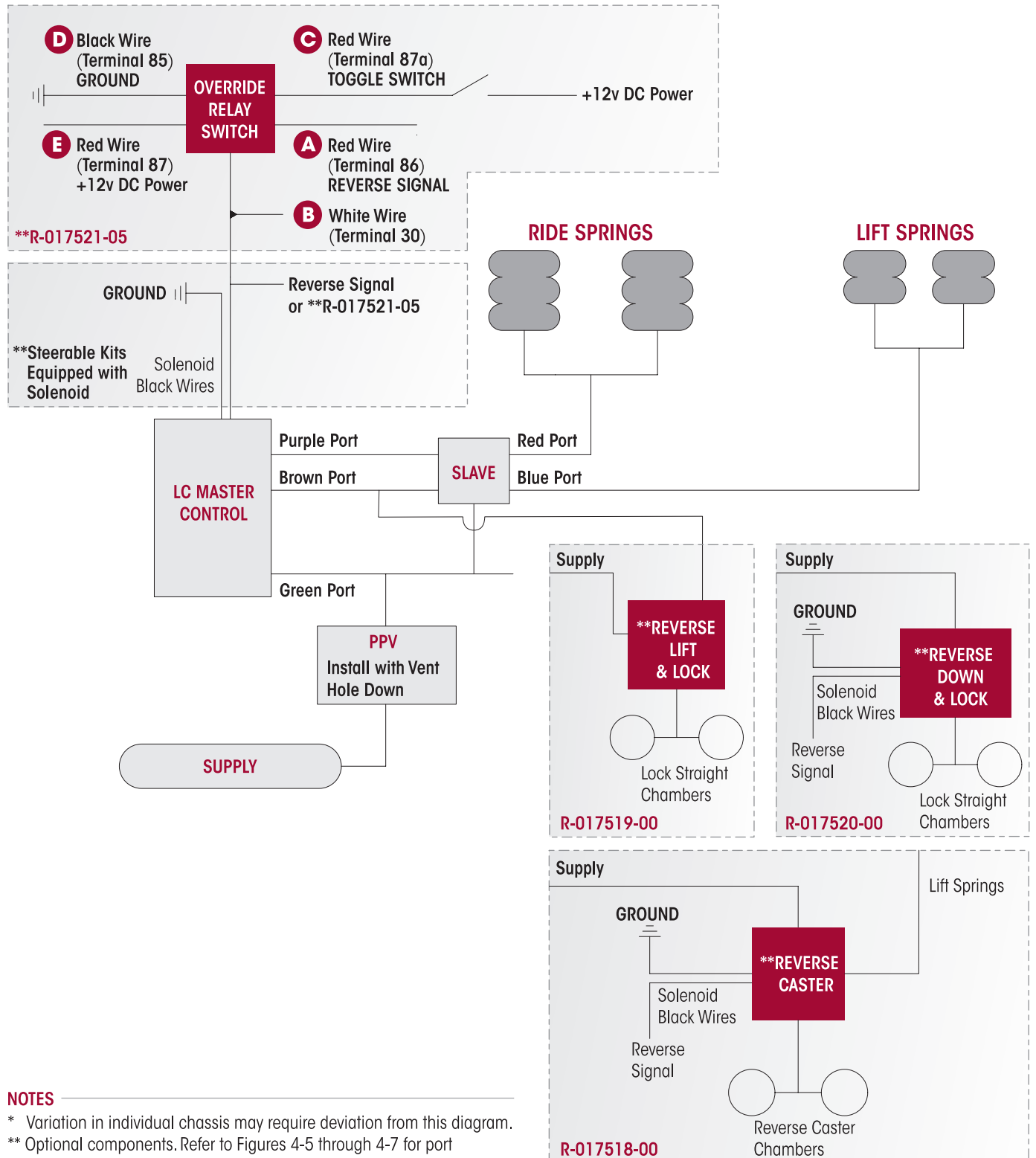

NOTES

- * Variation in individual chassis may require deviation from this diagram.
- ** Optional components. Refer to Figures 4-5 through 4-7 for port identification.

SECTION 6

Suspension Operation

RAISING YOUR LIFT AXLE

1. If the vehicle is already running, please proceed to Step 6.
2. Set parking brake of truck.
3. Turn your vehicle ignition to on position.
4. Press start switch and release when engine is started.
5. Allow the vehicle to idle until the vehicle air system pressure has reached the compressor cut-out pressure (usually 120 psi).
6. **If controls are Inside-Mounted** – Move the switch to **LIFT** position to immediately lift the axle.
7. **If controls are Outside-Mounted** – Ensure the vehicle is stopped and parking brake is set. Exit the vehicle, go to air control enclosure and open it. Move the push / pull valve to **LIFT** position to immediately lift the axle.
 - **Equipped with Electric Override Switch Part No. R-017521-05** – Turning the switch to the **ON** position will override the push / pull knob and raise the axle. Turning the switch off will immediately redeploy the axle. Likewise terminating power to the switch, such as turning the vehicle off, will immediately redeploy the axle.
8. Visually confirm the axle is lifting.

NOTE

Vehicle system air pressure may drop during suspension lifting process.

9. Lift axle should be completely lifted when the vehicle's air system pressure returns to the air compressor cut-out point (usually 120 psi).
10. Hendrickson recommends raising the lift axle when not in use and when off-road.

LOWERING YOUR LIFT AXLE

1. If the vehicle is already running, please proceed to Step 6.
2. Set parking brake of truck.
3. Turn your vehicle ignition to the **ON** position.
4. Press start switch and release when engine has started.
5. Allow the vehicle to idle until the vehicle air system pressure has reached the compressor cut-out (usually 120 psi).

CAUTION

DO NOT LOWER LIFT AXLE WHILE THE VEHICLE IS MOVING IN REVERSE OR TRAVELING AT MORE THAN 15 MPH. FAILURE TO DO SO CAN CAUSE COMPONENT DAMAGE.

6. **If the controls are Inside-Mounted** – Move the switch to **LOWER** position to immediately lower the axle.
7. **If the controls are Outside-Mounted** – Ensure the vehicle is stopped and the parking brake is set. Exit the vehicle, go to air control enclosure and open it. Move the push / pull valve to **LOWER** position to immediately lower the axle.
 - **Equipped with an Electric Override Switch Part No. R-017521-05** – If the axle fails to deploy, toggle the override switch in the cab to the **OFF** position.
8. Using the regulator, adjust air pressure on the gauge to the appropriate air pressure for vehicle load conditions. See air pressure load charts in the applicable Hendrickson Auxiliary Lift Axle Owner's Manual Literature No. OM-H754 (Steerable) or Literature No. OM-H757 (Non-Steerable).

NOTE

Air system pressure may drop during suspension lowering process.

9. Lift Axle should be completely lowered and supporting the pre-determined load when system air compressor cut-out point is reached (usually at 120 psi).

SECTION 7 Replacement Parts List

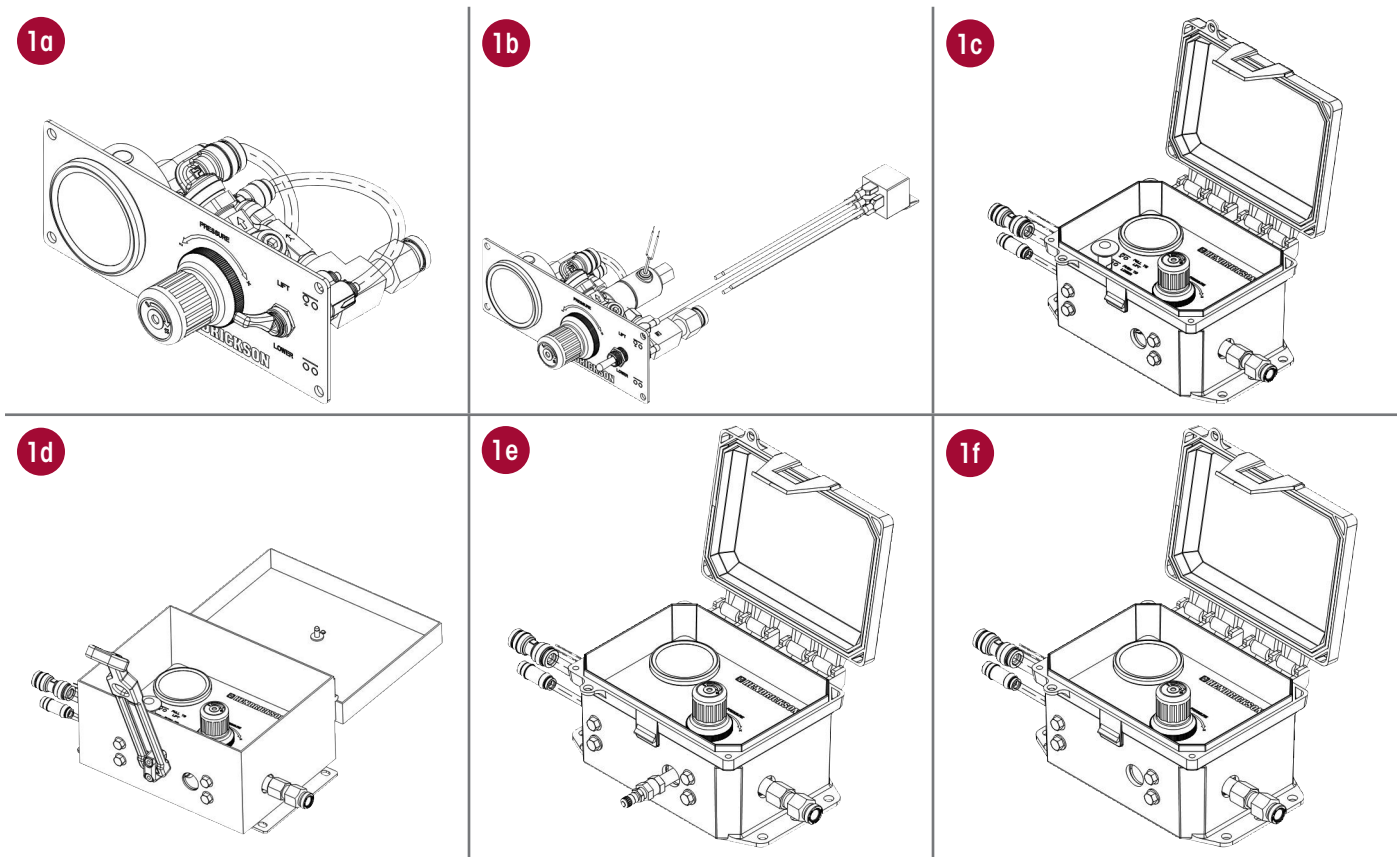

LIFT AXLE MASTER ASSEMBLY

ITEM	DESCRIPTION	PART NUMBER	QTY.
1	a LC-NSI or RSI	R-017512-00	1
	b LC-SSI, LSI or ASI	R-017513-00	1
	c LC-UCO, LCO, RCO or ACO	R-017514-00	1
	d LC-USO, LSO, RSO or ASO	R-017515-00	1
	e LC-MSO	R-017516-00	1
	f LC-MCA	R-017517-00	1

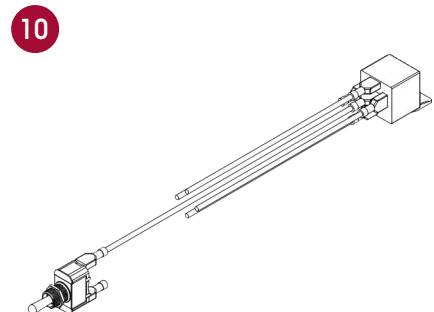
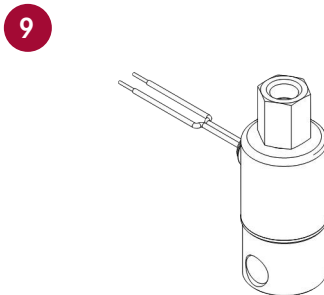
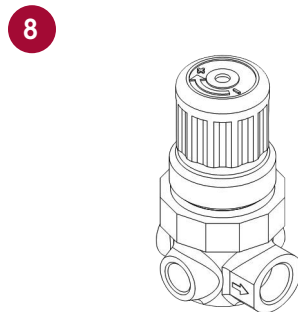
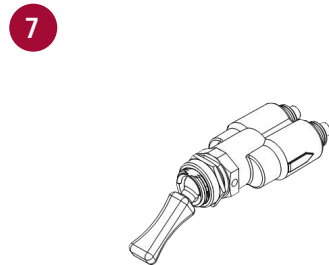
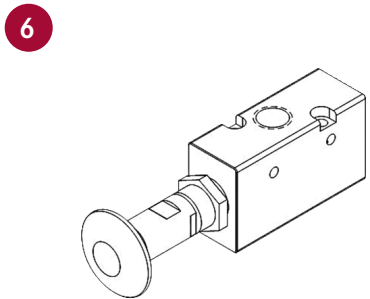
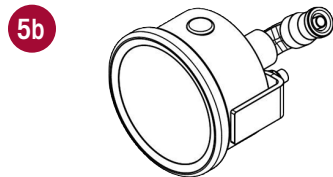
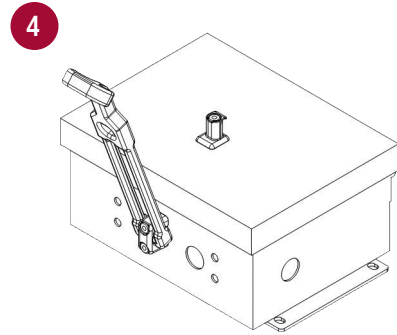
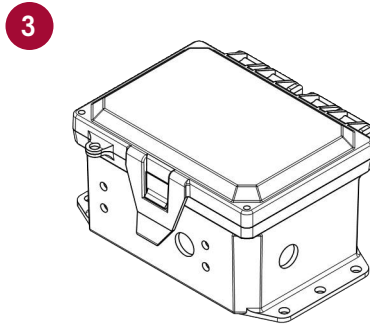
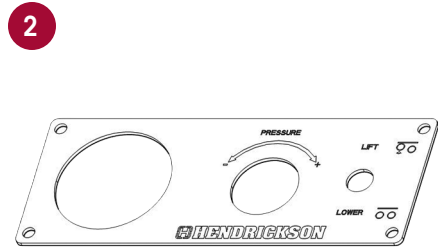

ITEM	DESCRIPTION	PART NUMBER	QTY.
2	Interior Faceplate	R-017521-11	1
3	Composite Enclosure Box	R-017521-14	1
4	Stainless Steel Enclosure Box	R-017521-15	1
5	a 2" Liquid Filled Gauge with Straight Fitting for LC- NSI, SSI, LSI, RSI or ASI	R-017521-08	1
	b 2" Liquid Filled Gauge with 90-Degree Fitting for LC-UCO, USO, MSO, MCA, LCO, LSO, RCO, RSO, ACO or ASO	R-017521-09	1
6	Pneumatic Push / Pull Valve	R-017521-10	1
7	Pneumatic Air Toggle Switch	R-017521-06	1
8	Regulator	R-017521-04	1
9	Solenoid Valve	R-017521-12	1
10	Electric Override Switch	R-017521-05	1



11

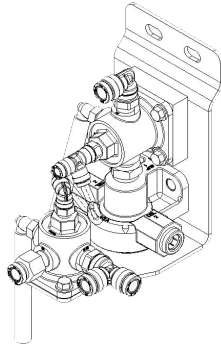

12

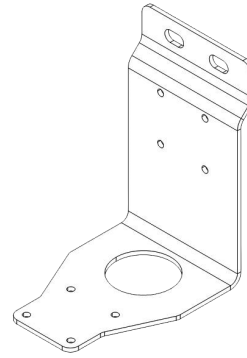

13

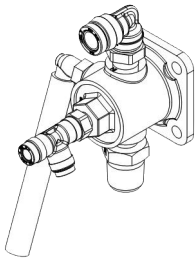

14

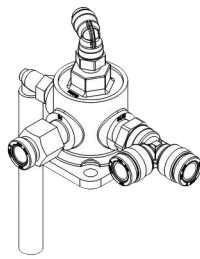

15

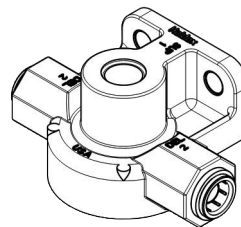

16

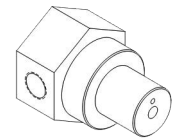

17

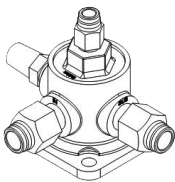

18

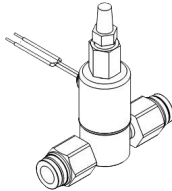

19

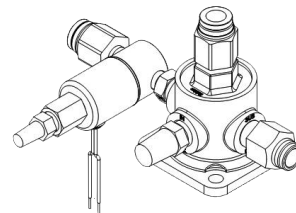

ITEM	DESCRIPTION	PART NUMBER	QTY.
11	Lift Axle Slave Assembly	R-017521-18	1
12	Slave Mounting Bracket	R-017521-03	1
13	Air Pilot Valve Slave Sub-Assembly (Ride Springs)	R-017521-17	1
14	Air Pilot Valve Slave Sub-Assembly (Lift Springs)	R-017521-16	1
15	Quick-Exhaust Valve	R-017521-02	1
16	Pressure Protection Valve	R-017521-13	1
17	Reverse Lift & Lock Valve Assembly	R-017519-00	1
18	Reverse Down & Lock Valve Assembly	R-017520-00	1
19	Reverse Caster Valve Assembly	R-017518-00	1



SECTION 8 Frequently Asked Questions

NOTE All brake plumbing installations must adhere to FMVSS-121 regulations. Modification to a vehicle's pneumatic system may alter its compliance to FMVSS-121 regulations.

QUESTION	RESPONSE
1 Where do I install my Hendrickson air kit control panel?	The Hendrickson air kit product line is available for Inside- and Outside-Mounting. Your particular application will be dictated by regulations in your state(s) of operation.
2 My axle goes down after the truck is shut down and it raises the entire chassis. Can I make the axle stay in the up position?	<p>All Outside-Mounted LC series air kits (excluding MCA, MSO) are set up to lower the axle to the down position when power is off. This symptom is an indication that the in-cab Electric Override Switch is in the LIFT position and the Outside-Mounted master control's push / pull valve is in the LOWER position. Therefore, move the push / pull valve to the LIFT position to immediately lift the axle.</p> <p>There are two (2) options to have the lift axle stay in the UP position without having to exit the vehicle to operate an Outside-Mounted control.</p> <p>Option 1: With your current air kit installed, rewire the +12v DC power source from the switch. Connect it to the battery instead of accessory ON power. Amp draw on battery is 0.58a to 7 watts.</p> <p>Option 2: Install the LC-MCA air control, which is designed to default to the lifted position with the power off. Changing to the LC-MCA will keep the axle up when the vehicle is shut down.</p>
3 Can I plumb my air kit in-line with my ride height control valve?	Complete vehicle assessment should be conducted considering primary suspension load share and vehicle handling performance. Specific instances can be reviewed by Hendrickson Technical Service Department.
4 At what pressure should the regulator be set?	Typically 70-120 psi. – All new lift axle and air control installations should be verified at a certified scale to determine correct pressures for vehicle loading. See air pressure load charts in the applicable Hendrickson Auxiliary Lift Axle Owner's Manual Literature No. OM-H754 (Steerable) or Literature No. OM-H757 (Non-Steerable). Improper vehicle loading can cause handling irregularities and component damage.
5 How do I identify my air kit?	For Inside-Mounted air kits, the identification tag is located on the back of the control panel. For Outside-Mounted air kits, the identification tag is located on the inside of the lid.
6 Why do steerable suspensions require auto lift in reverse?	Due to the positive caster angle built into Hendrickson steerable lift axles they are designed to track with the vehicle in forward motion. Moving in reverse the wheels will lock sideways and scrub the tires imparting high stress on the axle and leading to potential damage.
7 How does the reverse locking option engage?	The reverse locking option requires both an axle with the lock straight optional components installed and an air control specified to control the lock straight. The relay in the air control kit is wired to sense the activation of the reverse lights when the vehicle transitions to reverse gear. The relay will energize the lift axle control solenoid to switch the valve to lift mode.
9 Why does my pressure gauge show ride pressure when axle is raised?	The gauge will show a constant value for pressure dialed into the regulator. This makes technicians and operators aware of both ride pressure and stored pressure, which can cause severe personal injury and component damage.



SECTION 9 Troubleshooting Guide

LC AUXILIARY LIFT AXLE CONTROL KITS

TROUBLESHOOTING GUIDE		
PROBLEM	POSSIBLE CAUSE	CORRECTION
Automatic lift does not function	Non-functioning master push / pull valve	Replace push / pull valve with Part Number R-017521-10.
	Non-functioning master solenoid valve	Replace solenoid valve with Part Number R-017521-12.
	Non-functioning relay	Replace electric override switch with Part Number R-017521-05.
	Solenoid on master control is not being energized	Connect one black wire to vehicle ground and the second black wire to backup light power wire or Terminal 30 on supplied relay.
	Kinked, pinched, or broken air line	Replace air line.
	Supply air pressure insufficient to operate lift mechanism	Verify that you are receiving 100 psi minimum at the master control; Use calibrated gauge at supply line inlet.
	Non-functioning Quick-Exhaust Valve on slave	Replace Quick-Exhaust Valve with Part Number R-017521-02.
	Exhaust port(s) on master and / or slave are plugged	Remove obstruction.
	Air kit not properly plumbed	Confirm that air kit is plumbed per Figure 5-1, Plumbing & Wiring Diagram in this publication.
	Non-functioning master or slave control	Contact Hendrickson Warranty Department.
Manual lift does not function (push / pull valve or toggle switch)	Non-functioning master push / pull valve	Replace push / pull valve with Part Number R-017521-10.
	Non-functioning pneumatic toggle switch	Replace toggle switch with Part Number R-017521-06.
	Non-functioning relay	Replace electric override switch with Part Number R-017521-05.
	Electric override switch not properly installed	Confirm that the electric override switch is installed per this manual.
	Kinked, pinched, or broken air line	Replace air line.
	Supply air pressure insufficient to operate lift mechanism	Verify that you are receiving 100 psi minimum at the master control; Use calibrated gauge at supply line inlet.
	Non-functioning Quick-Exhaust Valve on slave	Replace Quick-Exhaust Valve with Part Number R-017521-02.
	Exhaust port(s) on master and / or slave are plugged	Remove obstruction.
	Air kit not properly plumbed	Confirm that air kit is plumbed per the plumbing schematic in this manual.
	Non-functioning master or slave control	Contact Hendrickson Warranty Department.
	Regulator turned down too low	Increase air pressure at regulator until desired load is carried at wheels.
	Truck in reverse gear	Place transmission in forward gear or neutral.
Solenoid valve is energized	Place transmission in forward gear or neutral and confirm push / pull valve or toggle switch are in LOWER mode (Excluding LC-NSI, RSI).	
Slow lift or lower times	Insufficient air flow or volume being delivered to master control	Confirm supply line size is 3/8" OD; increase air reservoir capacity.
	Insufficient air flow or volume being delivered to the air springs	Conform air line size is 3/8" to 1/2" going to air spring air lines.
Suspension does not carry rated load	Insufficient air pressure in ride springs	Increase pressure in ride springs by increasing regulator setting. Check pressure in ride springs at air spring inlet.
	Supply air pressure insufficient to operate lift mechanism	Verify that you are receiving 100 psi minimum at the master control; Use calibrated gauge at supply line inlet.
	Kinked, pinched or broken air line	Replace air line.
	Non-functioning air kit control panel	Contact Hendrickson Warranty Department.
	Incorrect lift axle ride height	Contact Hendrickson Technical Service Department.

*Actual product performance may vary depending upon vehicle configuration, operation, service and other factors.
All applications must comply with applicable Hendrickson specifications and must be approved by the respective vehicle manufacturer with the vehicle in its original, as-built configuration.
Contact Hendrickson for additional details regarding specifications, applications, capacities, and operation, service and maintenance instructions.*

Call Hendrickson at 800.660.2829 or 800.668.5360 in Canada for additional information.



www.hendrickson-intl.com

**SPECIALTY PRODUCTS -
AUXILIARY AXLE SYSTEMS**

277 North High Street
Hebron, OH 43025 USA
800.660.2829
740.929.5600 • Fax 740.929.5601

Hendrickson Canada

250 Chrysler Drive, Unit #3
Brampton, ON Canada L6S 6B6
800.668.5360
905.789.1030 • Fax 905.789.1033

H817 Rev A 04-19

© 2019 Hendrickson USA, L.L.C. All Rights Reserved. All trademarks shown are owned by Hendrickson USA, L.L.C., or one of its affiliates, in one or more countries.
Information contained in this literature was accurate at the time of publication. Product changes may have been made after the copyright date that are not reflected.

Printed in United States of America