



	Date	Group	No.	Release	Page
This Field Service Bulletin (FSB) replaces, "PV729-FSB728-005_M, Leveling Valve, Leak Test" (USA143247595) dated (11.2018).	5.2019	728	005	02	1(7)

Leveling Valve, Leak Test
CHU, CXU, GU, TD, PI, AN, GR

FSB 728-005, Leveling Valve, Leak Test

(May 2019)

Some Mack CHU, CXU, GU, TD, AN, PI, GR trucks built from July 6, 2015, and equipped with Barksdale suspension leveling valve may experience air leaks from the leveling valve after the vehicle is parked (**Shut Off**) for more than 10 minutes. Air can continue to be released through the exhaust port of the valve for up to 10 minutes. This is considered a normal function of the leveling valve and could be misdiagnosed as an air leak. To conduct a proper assessment of the leveling valve, follow the test and repair procedure outlined in this Field Service Bulletin (FSB). Fitting kits and leveling valves are available if any leveling valves or fittings show signs of leakage and require replacement.

Note: This bulletin does not apply to Mack Trucks Australia.

Required Parts

Barksdale Repair and Fitting Kits			
Item #	OEM Valve Part Number	Fitting Kit Part Number	** Fitting Torque Values
1	22586531	85154049	13 ± 2 Nm (120 ± 20 in-lb)
2	22586327	85154049	13 ± 2 Nm (120 ± 20 in-lb)
3	22612887	85154050	13 ± 2 Nm (120 ± 20 in-lb)

** Hand start all fitting into the valve, then torque to specification.

Decommissioning the Truck for Repair

You must read and understand the precautions and guidelines in Service Information, group 70, "General Safety Practices, Frame, Springs, Shocks & Wheels" before performing this procedure. If you are not properly trained and certified in this procedure, ask your supervisor for training before you perform it.

NOTE: Information is subject to change without notice. Illustrations are used for reference only and can differ slightly from the actual vehicle being serviced. However, key components addressed in this information are represented as accurately as possible.

- 1 Park the vehicle on a flat and level surface.
- 2 Apply the parking brake.
- 3 Place the transmission in neutral or park.
- 4 Install the wheel chocks.

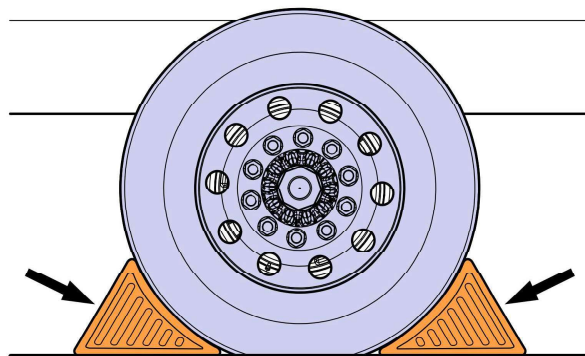

W7086748

Leveling Valve Leak Test Procedure

- 1 Start the truck and run engine until the truck reaches the proper operating air pressure of 80 to 120 psi.
- 2 Shut down the engine.
- 3 Wait approximately 10 minutes for the air suspension system to stabilize.

Note: Due to the design of this leveling valve, it may take 10 minutes to stop adjusting height once vehicle is parked on level surface. It is normal to hear air flowing from exhaust port of valve, or air flowing into air springs during this time.

- 4 Listen for air leakage. If audible air is detected after 10 minutes, proceed to Step 5.
- 5 Using a spray bottle, fill it soap-and-water solution for air leak testing.
- 6 Spray soap-and-water solution on all fittings, airline tube connections and valve body as shown in the figure below.

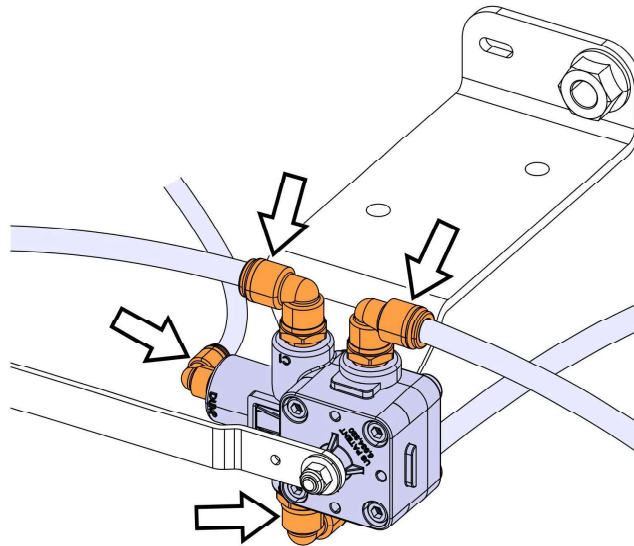

W7142086

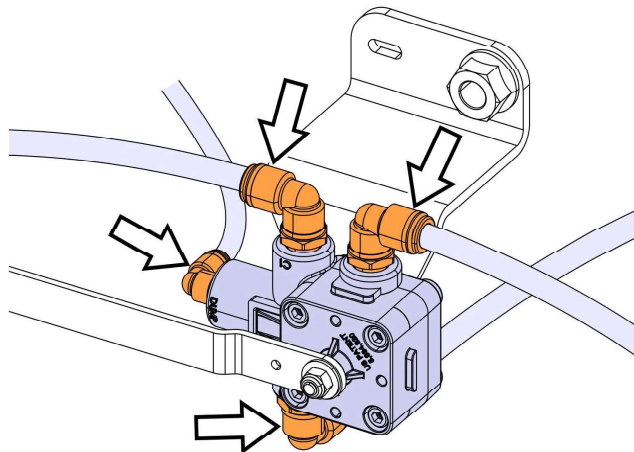

W7142087

- 7 If air bubbles form in any area of the fittings near the valve body, re-tighten fittings and repeat soap-and-water solution test.
- 8 If air bubbles form at airline tube connections, re-cut tubing, re- insert into fittings and repeat soap-and-water solution test.
- 9 If any fittings show signs of leakage after steps 7 and 8 are complete, replace only the fittings that are leaking.

Note: Do not replace the entire valve.

- 10 Fitting kits 85154049 and 85154050 are available in PDC. See **Barksdale Repair and Fitting Kits** table for the correct repair part numbers.

- 11 If there are still bubbles present after Step 10, please replace the valve and submit the valve through normal warranty process for further analysis.

Note: When replacing the leveling valve, do not remove the valve mounting bracket unless it is necessary.

Note: The presence of bubbles does not definitively indicate that a valve has failed.

Note: Any valve returned under warranty will be subject to mandatory return and subsequent testing. If valve is found to be fault free no warranty credit will be issued.

| Barksdale Leveling Valve Troubleshooting Video

A Barksdale leveling valve troubleshooting video is available on Barksdale's website.

- 1 Use the link in this body of text which goes to troubleshooting video (on YouTube). In order to access the link, please go to www.barksdale.com (1).
- 2 Click on the **Air Suspension Valve** option from the products menu as shown in the image below (2).

Barksdale®
CONTROL PRODUCTS
Barksdale, Inc./Barksdale GmbH
A Subsidiary of Crane Co.

Home Products Product Configurator Markets Distributors Catalogs

- Pressure ▶
- Valves and Regulators ▶
- Temperature ▶
- Level ▶
- Air Suspension Valve** ◀ ②
- Dynalco® Products ▶
- Customize your own solution

Products

Product Availability

RapidNet® ...All In-Stock Products Shipped

Enter Model No. Enter C

Overview

W7146913

- 3 (3) Once the air suspension valve page opens, scroll down to the section titled “**52341 Series Air Suspension Valve with Integral Dump.**”
- 4 In that section you will see a link to the leveling valve leak test video under the description “**Leakage Test Troubleshooting Video Tutorial**” (4) as shown in the figure below.

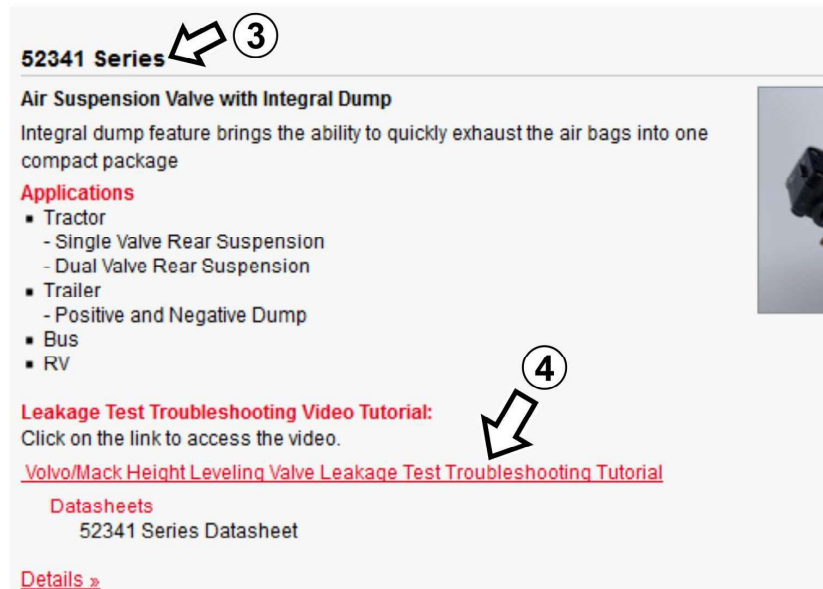

52341 Series 3

Air Suspension Valve with Integral Dump

Integral dump feature brings the ability to quickly exhaust the air bags into one compact package

Applications

- Tractor
 - Single Valve Rear Suspension
 - Dual Valve Rear Suspension
- Trailer
 - Positive and Negative Dump
- Bus
- RV

Leakage Test Troubleshooting Video Tutorial:
Click on the link to access the video.

[Volvo/Mack Height Leveling Valve Leakage Test Troubleshooting Tutorial](#)

Datasheets
[52341 Series Datasheet](#)

[Details »](#)

W7146914

- 5 The link will connect to the YouTube video below.



W7146915

Commissioning the Truck for Operation

- 1 Start the truck and build the air system up to normal operating pressure.
- 2 Remove the wheel chocks.

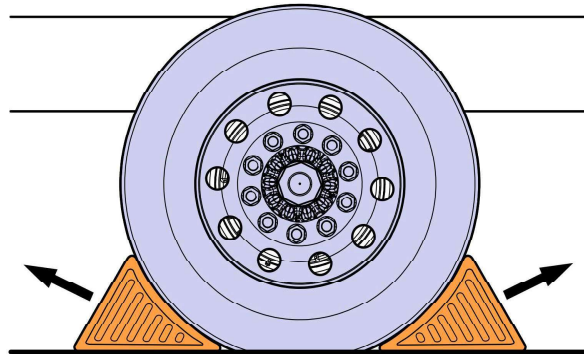

W7086759

Reimbursement

This repair may be eligible for reimbursement if a product failure was experienced within time and mileage limits of the applicable Warranty coverage. Reimbursement is obtained via the normal claim handling process.	UCHP Reimbursement
Claim Type (used only when uploading from the Dealer Bus. Sys.)	01
Labor Code	
Primary Labor Code (Leveling Valve, Leak Test)	7281-06-09-01, 0.5 hrs.
Labor Code (Air Fitting, Replacement)	5634-03-02-02, 0.4 hrs.
Labor Code (Air Fitting, Replacement) Each Additional	5634-03-03-01, 0.1 hrs.
Labor Code (Leveling Valve, Replacement)	7641-03-02-01, 0.8 hrs.
Causal Part	22586531, 22586327, 22612887

Mack Trucks reserves the right to make any changes in design or to make additions to or upon its products without incurring any obligations to install the same on vehicles previously built.