

Technical Service Bulletin

Mazda North American Operations
Irvine, CA 92618-2922



Subject: SPECIAL TOOL SHIPMENT - JUNE 2019	Bulletin No.: 00-004/19
	Last Issued: 06/11/2019

APPLICABLE MODEL(S)/VINS
2019 Mazda3

DESCRIPTION

DESCRIPTION/PRICING

In support of the newly launched 2019 Mazda3, Mazda will ship to all dealers one new Special Service Tool (SST). The SST will be shipped automatically by Mazda's tool vendor, Bosch, during June 2019.

The following SST is the latest addition to the Mazda Required Tool (MRT) list.

Part Number	Description	Pricing
49JP-02-002A-1	Lock Ring Wrench (for AWD Set Plate Removal/Installation)	\$122.00

BILLING INFORMATION

Tool(s) will be automatically invoiced to your dealer parts account statement. If your accounting department has any questions regarding this invoicing, please call Mazda Special Service Tools (949-852-7240). **DO NOT send your payment to Bosch.**

SHIPPING INFORMATION

Tool(s) will be shipped via UPS ground to your Service Department in June 2019.

Please advise your shipping/receiving personnel of this tool shipment.

OBTAINING ADDITIONAL TOOLS



To order additional SSTs, submit orders using Mazda e-Store at <http://dealers.mazdausa.com>.

CUSTOMER SERVICE INFORMATION

For warranty or product information call Bosch Customer Service at (800) 533-5338. Customer service representatives are available from 8:00 AM until 8:00 PM ET, Monday through Friday.

CONSUMER NOTICE: The information and instructions in this bulletin are intended for use by skilled technicians. Mazda technicians utilize the proper tools/equipment and take training to correctly and safely maintain Mazda vehicles. These instructions should not be performed by "do-it-yourselfers." Customers should not assume this bulletin applies to their vehicle or that their vehicle will develop the described concern. To determine if the information applies, customers should contact their nearest authorized Mazda dealership. Mazda North American Operations reserves the right to alter the specifications and contents of this bulletin without obligation or advance notice. All rights reserved. No part of this bulletin may be reproduced in any form or by any means, electronic or mechanical---including photocopying and recording and the use of any kind of information storage and retrieval system ---without permission in writing.

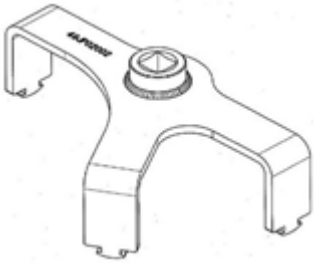
SPECIAL SERVICE TOOL (SST) AND USAGE

PART NUMBER /	OVERVIEW	USAGE
<p>NAME: 49JP-02-002A-1 Lock Ring Wrench</p> <p>APPLICABLE MODELS: 2019 Mazda3 AWD</p> <p>USAGE: To remove/install the Set Plate.</p>		

CONSUMER NOTICE: The information and instructions in this bulletin are intended for use by skilled technicians. Mazda technicians utilize the proper tools/equipment and take training to correctly and safely maintain Mazda vehicles. These instructions should not be performed by "do-it-yourselfers." Customers should not assume this bulletin applies to their vehicle or that their vehicle will develop the described concern. To determine if the information applies, customers should contact their nearest authorized Mazda dealership. Mazda North American Operations reserves the right to alter the specifications and contents of this bulletin without obligation or advance notice. All rights reserved. No part of this bulletin may be reproduced in any form or by any means, electronic or mechanical---including photocopying and recording and the use of any kind of information storage and retrieval system ---without permission in writing.