



Service Bulletin

Bulletin No.: 18-NA-367

Date: May, 2019

TECHNICAL

Subject: Diagnostic Tip for Malfunction Indicator Lamp (MIL) Illuminated with DTC P305F, P058B and/or P058D

This Bulletin replaces PIC6112 and PI1412A. Please discard PIC6112 and PI1412A.

Brand:	Model:	Model Year:		VIN:		Engine:	Transmission:
		from	to	from	to		
Chevrolet	Impala (VIN 1)	2014	2016				
	Malibu	2014	2015			2.5L (RPO LKW)	
	Malibu Limited (VIN 1)	2016	2016			2.5L (RPO LCV)	

Involved Region or Country	North America, Israel
Additional Options (RPOs)	Equipped with Engine Control, Stop-Start System (RPO KL9)
Condition	Some customers may comment that the Malfunction Indicator Lamp (MIL) is illuminated. Some technicians may find one or more of the following DTCs set, current or in history, in the Engine Control Module (ECM): <ul style="list-style-type: none"> • P305F: Dual Battery Control Module Performance • P058B: Battery Monitor Module Current Monitoring Performance • P058D: Battery Monitor Module Voltage Monitoring Performance
Cause	This condition may be caused by one or more of the following: <ul style="list-style-type: none"> • Loose ring terminal at negative battery terminal • Fretting or corrosion on female terminal pins in 4 pin connector • Loose splice in harness ground circuit • Defective Battery Control Module
Correction	If you encounter a vehicle with the above concern, prior to completing any repairs, perform the following Service Procedure steps:

Service Procedure

Inspect the following if DTC P305F has been set:

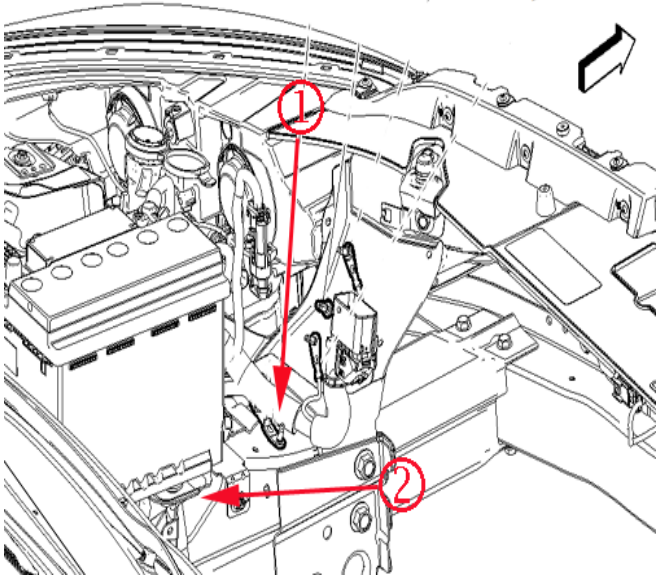

4005667

1. Check state of health of auxiliary battery with the GR8 tester. Not just a state of charge check.
 - If low, replace the battery, clear codes and re-check.
 - If good, proceed to step 2.
 2. Check ground resistance from the Dual Battery Isolation Module (DBIM) to G103. Wiggle the harness (1) and negative battery terminal connections during test to look for varied resistance values.
 - If resistance is greater than 0.5 ohms, or changes more than 1 ohm, then inspect ground connections and/or splice in the harness about 1.5 ft. from the connector end.
- ⇒ Fix poor connections, clear codes and re-check.
- If resistance is less than 0.5 ohms, proceed to step 3.
3. Verify the engine harness is not pinched underneath the main battery tray (2).

Note: The DBIM is located on the fuse block assembly. If found the cause of the concern, the Battery Distribution Fuse Block must be replaced.

4. Replace the battery distribution fuse block and wiring harness connector, clear codes and re-check.

Inspect the following if DTC P058B and/or P058D is set current or in history:

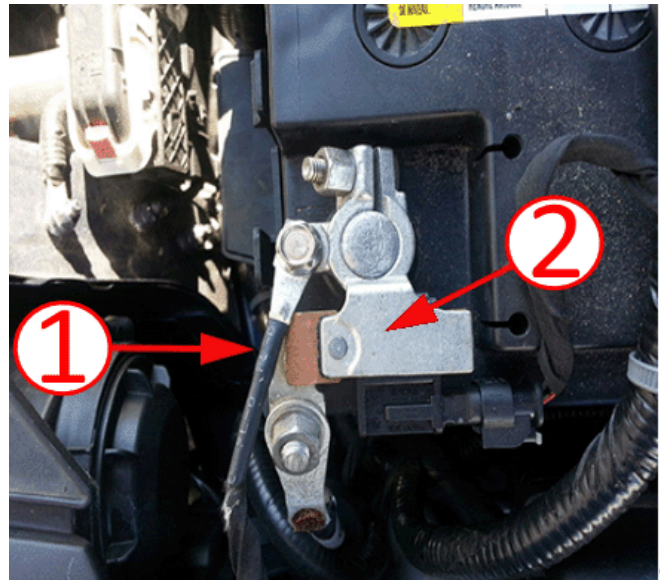

5148609

1. Inspect the orientation of the grounding ring for circuit 150 (1) to the B110 Battery Sensor Module (2).

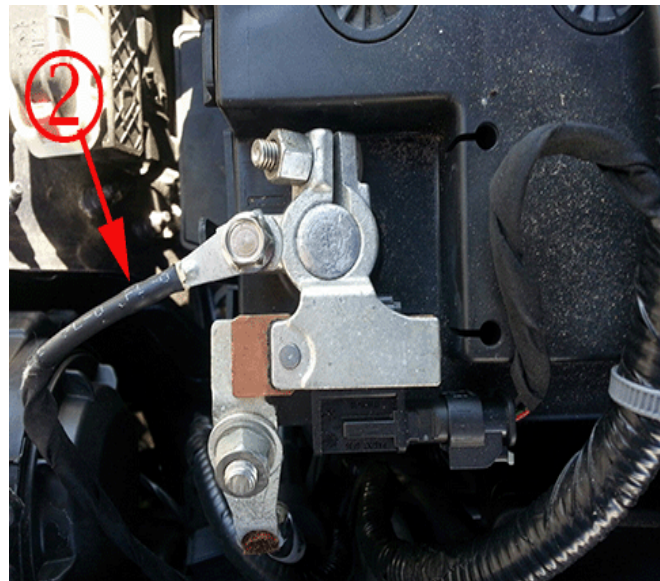

4245353

- If found contacting the sensor, reposition the terminal away from the sensor as shown above, and tighten the bolt to 5 N•m (44 lb in).

2. Check ground resistance of Dual Battery Isolation Module (DBIM) to G103. Wiggle the harness and negative battery terminal connections during the test to look for varied resistance values.
 - If resistance is greater than 0.5 ohms or changes more than 1 ohm:
 - 2.1. Inspect ground connections and/or splice in the harness about 1.5 ft. from the connector end.
 - 2.2. Fix poor connection and replace the module.
 - 2.3. Clear codes and re-check.
 - If resistance is less than 0.5 ohms, proceed to step 3.
3. Replace the battery distribution fuse block and wiring harness connector, clear codes and re-check.

Parts Information

Causal Part	Description	Part Number	Qty
N/A	BLOCK, BAT DISTRIBUTION ENG COMPT FUSE	23223079	1
N/A	CONNECTOR KIT, WRG HARN	13581092	1

Version	2
Modified	Released December 06, 2018 May 01, 2019 – Added the 2014-2016 Chevrolet Impala (VIN 1).

Warranty Information

Note: For vehicles repaired under warranty, use the appropriate labor operation for the repair performed.

For vehicles repaired under the Bumper-to-Bumper coverage (Canada Base Warranty coverage), use the following labor operation. Reference the Applicable Warranties section of Investigate Vehicle History (IVH) for coverage information.

Labor Operation	Description	Labor Time
5430360	Front Compartment Fuse Block Replacement	Use Published Labor Operation Time
5430860	Connector Kit Replacement	
2680358*	Check the Orientation of The Grounding Ring	0.2 hr

*This is a unique Labor Operation for Bulletin use only.

