

## Technical product information

<b>Topic</b>	Creaking noise from the front suspension when manoeuvring
<b>Market area</b>	Bentley: worldwide (2WBE),Hongkong-Macau (5HK)
<b>Brand</b>	Bentley
<b>Transaction No.</b>	2048616/5
<b>Level</b>	EH
<b>Status</b>	Approval
<b>Release date</b>	

### New customer code

Object of complaint	Complaint type	Position
running gear -> shock absorber/suspension control -> jounce	noise, vibration -> creak	front

### New workshop code

Object of complaint	Complaint type	Position
running gear -> running gear, springs, shock absorbers -> axle member mount	noise, vibration -> noise	left
running gear -> running gear, springs, shock absorbers -> axle member mount	noise, vibration -> noise	right

## Vehicle data

### Bentayga

#### Sales types

Type	MY	Brand	Designation	Engine code	Gearbox code	Final drive code
4V1*	2017	E		*	*	*
4V1*	2018	E		*	*	*
4V1*	2019	E		*	*	*

## Documents

Document name
master.xml
creaklowersuspensionleverbush.docx
kovomoanddiesel.docx
lowersuspensionleverw12only.docx
transmissionmountsfront.docx

## Customer statement / workshop findings

Creaking noise from the front suspension when manoeuvring

## Technical background

Front suspension entering bump phase during braking can produce an audible creak from the lower control arm hydraulic mounts

## Production change

\*

## Measure

Listen to the below video link and compare it to the customer complaint:

<https://vimeo.com/291048296>

The noise present in the video is caused by defective Lower suspension lever - Rear - Hydraulic mounts. In order to reproduce the noise this bush must be twisted, therefore the noise can appear in the following circumstances

- When performing parking manoeuvres with the brake applied
- When steering from lock to lock with the vehicle in motion and the brake applied
- When the vehicle is moved with steering input over uneven surfaces (for e.g. a ramp or speed bump)

If the customer complaint occurs in any of the above circumstances and the noise can be clearly assigned to the above video link in this TPI, then replace the right hand front and left hand front rear most lower suspension lever inner hydraulic mounts - Refer to Repair manual Rep. Gr. 40 front suspension, lower suspension lever bushes – to remove and fit **NOTE: Should the remove and refit instructions not be visible within the Repair manual please refer to the attached documents, please ensure the correct document is followed as the remove and refit procedures for the front rear most lower suspension levers removal is different depending on type of engine which is fitted**

**NOTE: The lubricant quoted within the procedure should be sourced locally or use a suitable alternative of the same specification**

Figure 1 shows for example the left hand front rear most lower suspension lever (A) the hydraulic mount which must be changed is located at (B)

**NOTE: Ensure the right and left hand side hydraulic mounts are replaced**

**Within the Repair manual procedure there are single use items which must be replaced and not reused. Ensure that new replacements are available prior to starting this procedure – Refer to Elsa pro and ETKA parts catalogue**

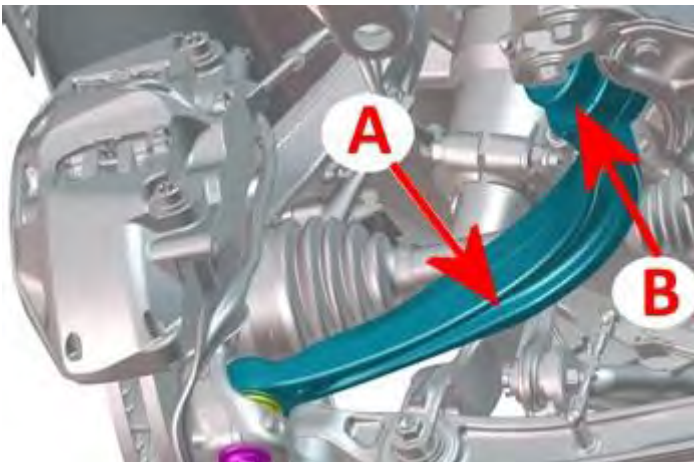

Figure 1

## Warranty accounting instructions

### **Bentayga W12**

Warranty type 110 or 910  
 Labour Operation Code 40 20 56 00 (Use 40 20 56 99 until 09/05/19)  
 Damage Service Number 40 20  
 Damage Code 00 20  
 Time 590 TU

### **Bentayga Kovomo V8**

Warranty type 110 or 910  
 Labour Operation Code 40 20 56 20 (Use 40 20 56 99 until 09/05/19)  
 Damage Service Number 40 20  
 Damage Code 00 20  
 Time 260 TU

**Bentayga Diesel**

Warranty type 110 or 910  
Labour Operation Code 40 20 56 40 (Use 40 20 56 99 until 09/05/19)  
Damage Service Number 40 20  
Damage Code 00 20  
Time 270 TU

**Parts information**

<b>Part number</b>	<b>Description</b>	<b>Quantity</b>
Refer to ETKA parts catalogue	Hydraulic mounts	2

## Lower suspension lever (W12) - Rear - To remove and fit

### General Information

The following procedure is for the LH lower rear lever. The procedure for the RH lever is the same except where stated.

Access is only possible after the removal of the front subframe.

### Special tools and workshop equipment required

- ◆ Ball joint puller -T10444-

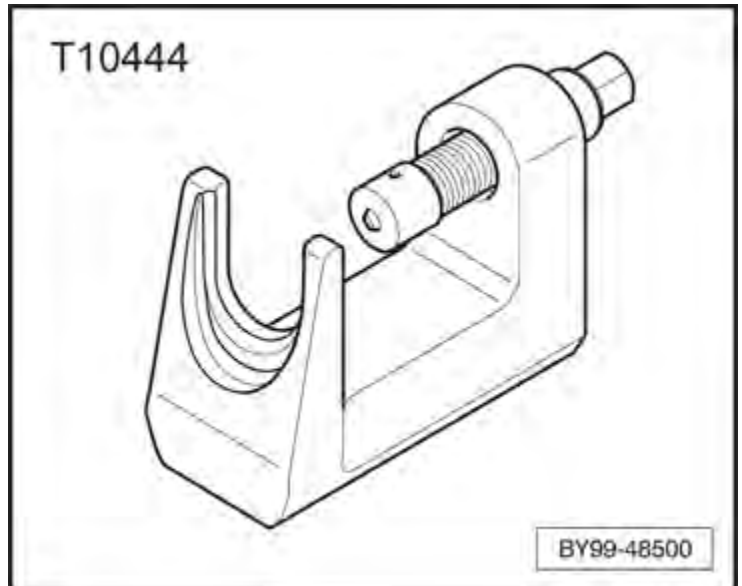

- ◆ Vehicle tester

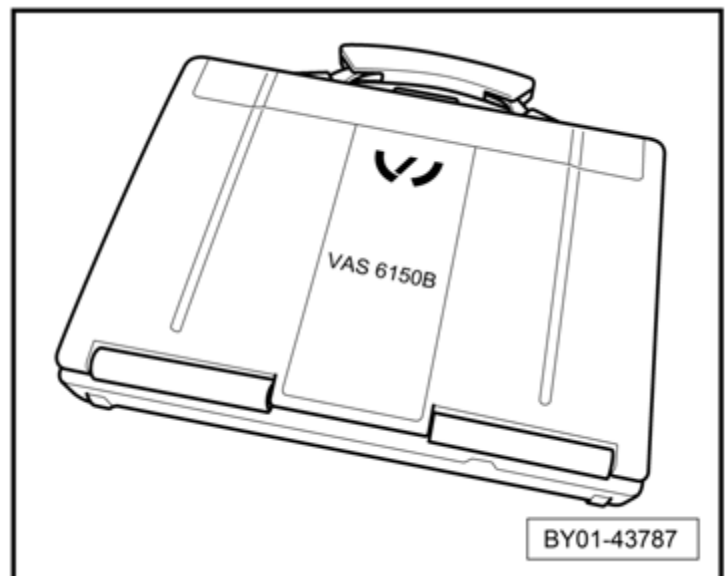

◆ 21 mm Ring insert -VAG 1332/7-

### Torque tightening values

Unless otherwise shown, standard torque values apply.

→ Rep.-Gr.00

### Single use items

Within this procedure there are single use items which must be replaced and not reused. Ensure that new replacements are available prior to starting this procedure.

### Removal

- Remove the front subframe. Refer to "Front subframe - To remove and fit". → Rep.-Gr.40
- Remove the two fixings -**arrows**- and the heatshield -**1**-.

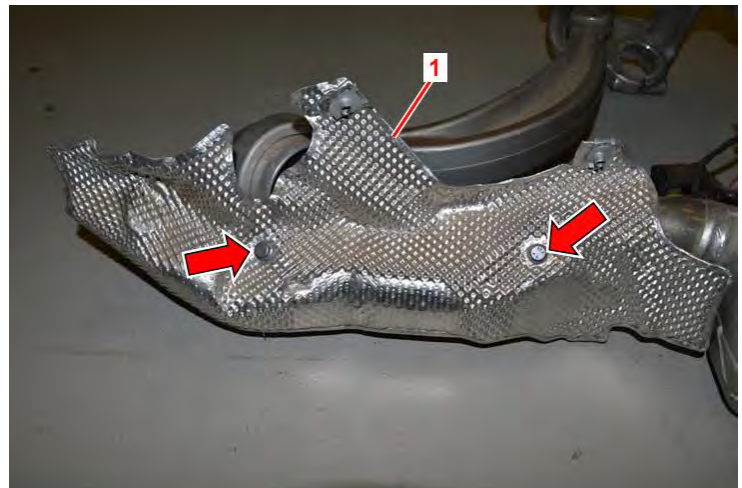
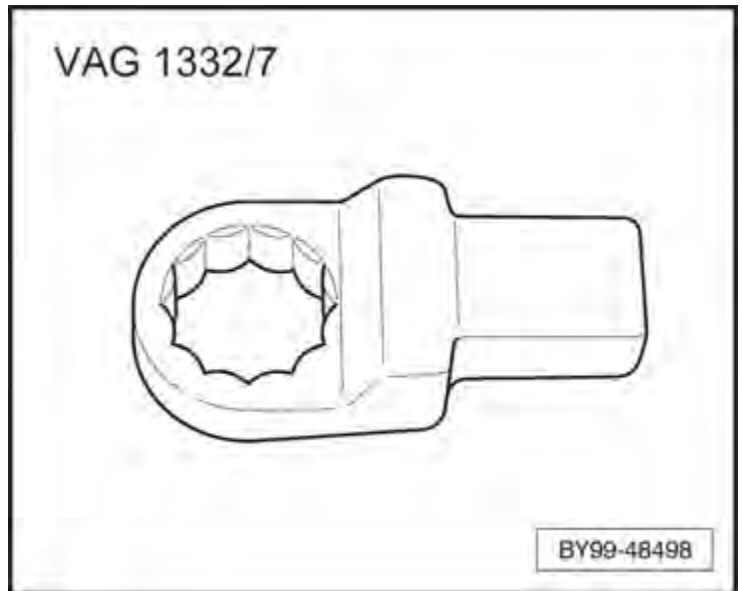

- On the outer section of the lower lever and using 21 mm Ring insert -VAG 1332/7-, release the nut -**arrow**- (140 Nm) until it is flush with the end of the thread of the ball joint.
- Using Ball joint puller -T10444-, "break" the taper pin of the ball joint.
- Remove the Ball joint puller -T10444-, remove and DISCARD the nut -**arrow**-.

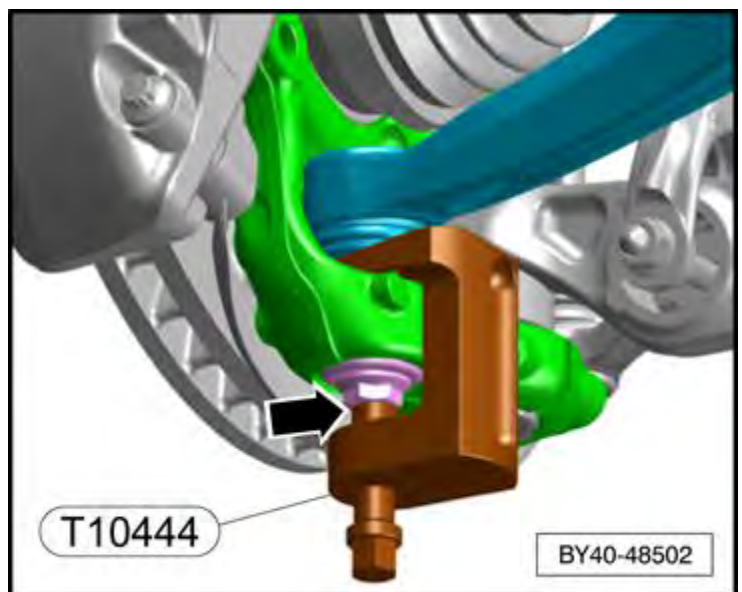

- Remove and DISCARD the fixings -2 and 3- (70 Nm + 180°.
- Manoeuvre the lower lever -1- out from the sub frame.

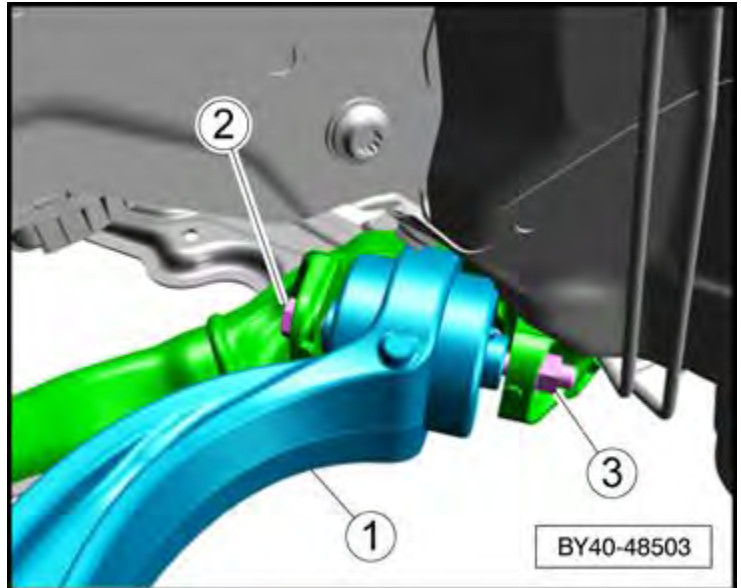

**Installation**

Installation is the reverse of removal procedure, noting the following.

- Secure the outer section of the lower lever -1- to the wheel bearing housing with a NEW fixing -arrow- but do NOT yet torque tighten.

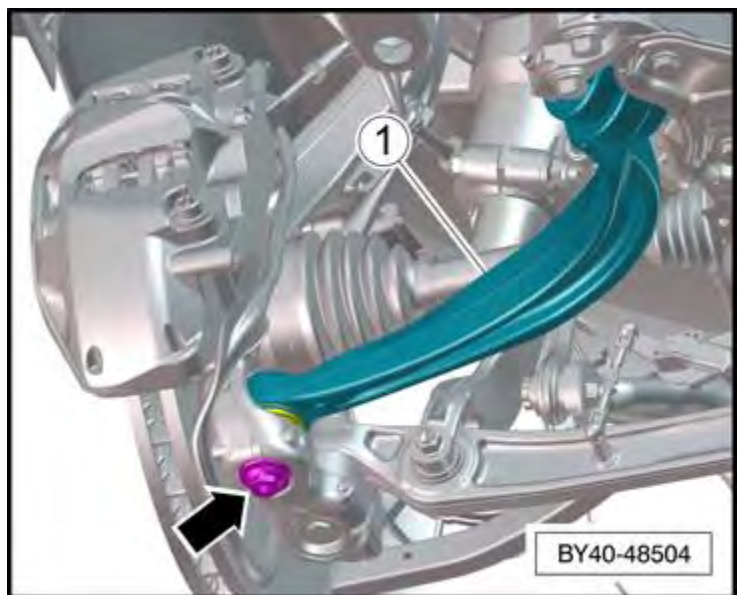

- Secure the inner section of the lower lever -1- to the sub frame with NEW fixings -2 and 3- but do NOT yet torque tighten.

**⚠ Caution**

There is a requirement that any suspension component with bonded rubber bushes, all levers and the bearing housing MUST be set at standard ride height before tightening the fixings.

Bonded rubber bushes can only be turned to a limited extent. The suspension mountings must therefore only be tightened when the suspension is in the unladen position or normal level.

Failure to comply will result in the lever bushes undertaking excessive torsional twist, resulting in rupture and complete failure of the rubber inserts.

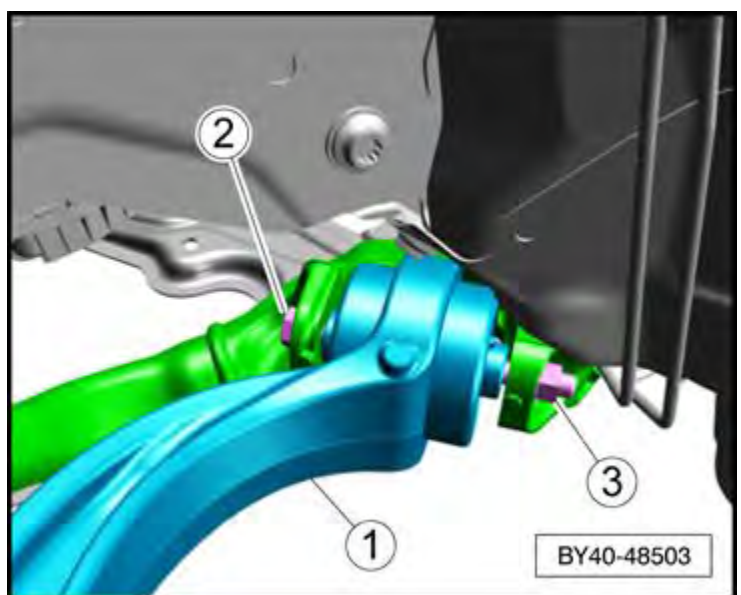

The suspension must be set to a specific angle prior to torque tightening the fixings and after the subframe has been refitted.

- Refit the front subframe. Refer to "Front subframe - To remove and fit". → [Rep.-Gr.40](#)
- Position the Hydraulic support stand - ASE40611000000 or VAG 1383-A- beneath the wheel bearing housing and jack until the suspension levers are at the correct ride height level. Refer to "Raising the wheel bearing housing - To tighten bolts". → [Rep.-Gr.40](#)
- With the wheel bearing housing in the raised position, torque tighten the inner fixings -**2 and 3**- to 70 Nm + 180°.
- Remove the Hydraulic support -ASE40611000000 or VAG 1383-A-.

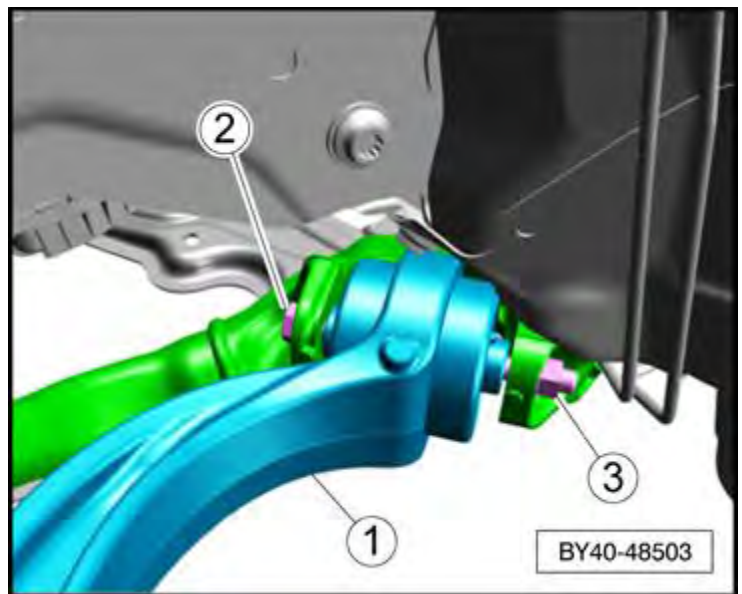

- Using 21 mm Ring insert -VAG 1332/7- , torque tighten the nut -**arrow**- securing the ball joint on the outer section of the lower lever -**1**- to the wheel bearing housing to 140 Nm.
- Take the car out of "Jack" mode. → [Rep.-Gr.99](#)
- Charge the air suspension. Refer to "Air suspension system - To discharge and charge". → [Rep.-Gr.43](#)

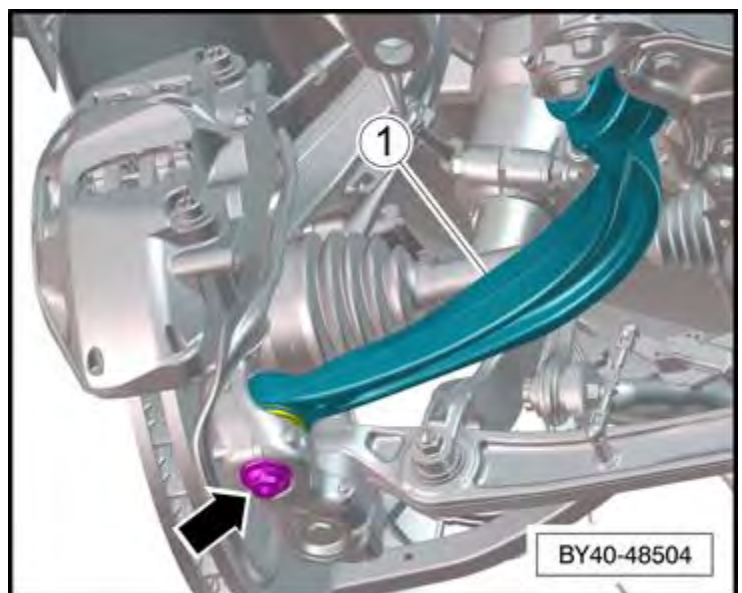

## Automatic transmission mounts - Front - To remove and fit

### General Information

This procedure is for removing the front transmission mounts Gearbox mounting valve 1 -N262- and Gearbox mounting valve 2 -N263-.

The procedure for the LH side is different to the RH side. Refer to the appropriate section below.

### Special tools and workshop equipment required

None

### Torque tightening values

Unless otherwise shown, standard torque values apply.→ [Rep.-Gr.00](#)

### Single use items

Within this procedure there are single use items which must be replaced and not reused. Ensure that new replacements are available prior to starting this procedure.

## Removal — LH side

- Remove the front road wheels. Refer to "Road wheel - To remove and fit". → [Rep.-Gr.44](#)
- Remove the front undersheets -**2 & 3**-.
- Remove the front subframe brace. Refer to
- "Brace front subframe - To remove and fit". → [Rep.-Gr.40](#)

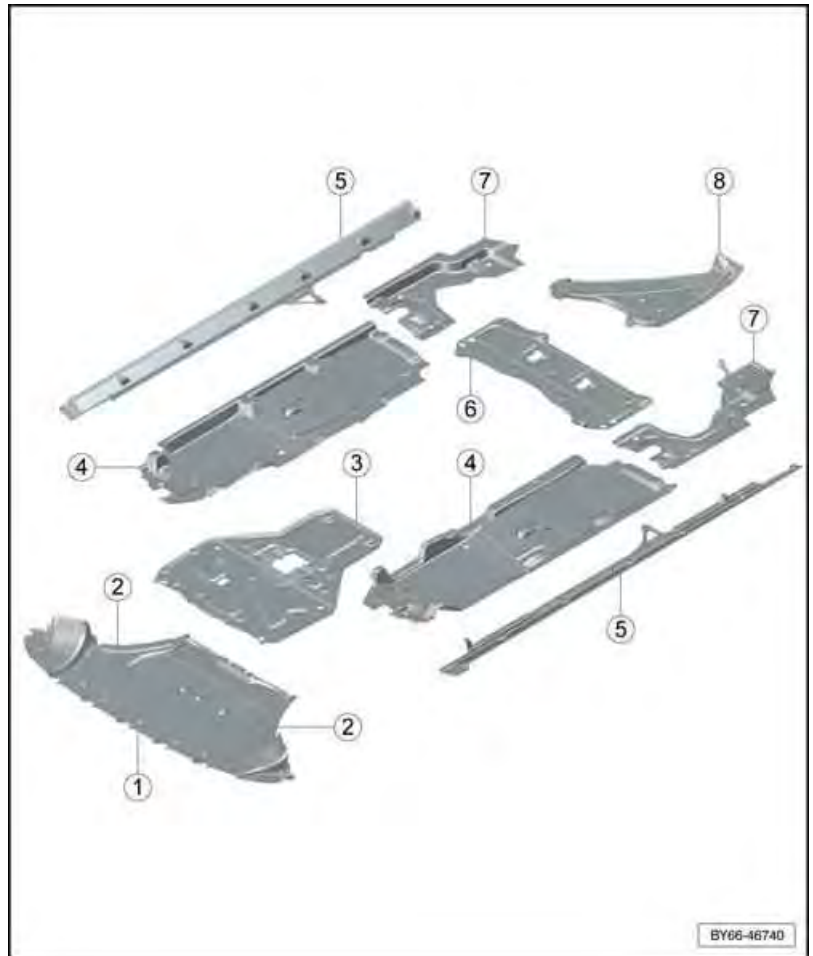

- Disconnect the electrical connection -**arrow**- to the transmission mount assembly.
- Remove the three fixings -**1**- (10 Nm) and the upper heatshield -**2**-.



- Carefully bend the lower heatshield -1- downwards
- and remove the three fixings -2- (10 Nm) and the heatshield -3- from the mounting bracket.
- Detach the coolant hose at the clipping point -**arrow**-.

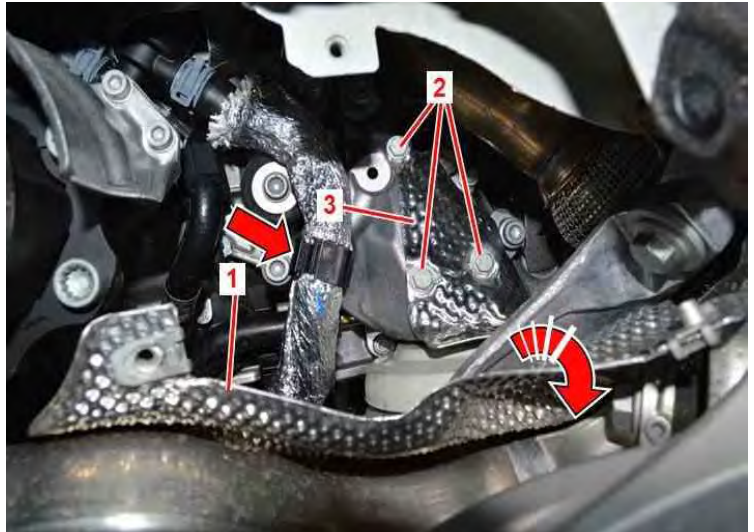

- Remove the M12 "Multispline" fixing -**arrow**- (55 Nm) from the mount.



- Remove the three fixings -**arrows**- (20 Nm) and detach the inner transmission mount bracket -1- and remove from the vehicle.

**⚠ Caution**

Prior to removing ANY of the fixings -**arrows**-, mark the position of the transmission mounting bracket -1- against the automatic transmission housing in order to retain the correct height settings of the bracket -1-. Failure to do so will result in premature mount failure!

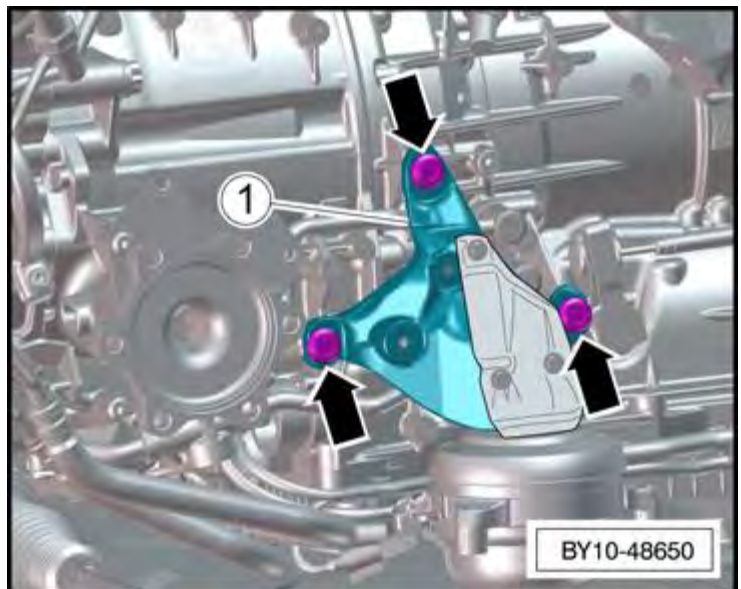

- Carefully bend the heatshield -1- back into the upright position and remove the outermost mount fixing -2- (55 Nm).
- Manoeuvre the mount and outer bracket assembly out from the vehicle.

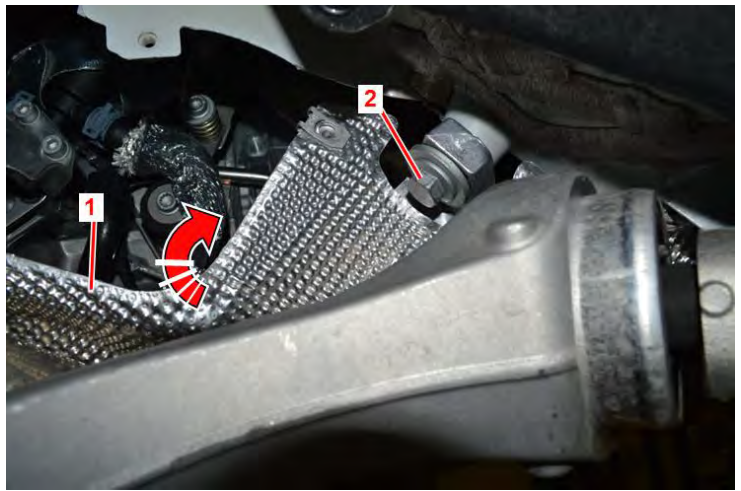

#### Replacement of the transmission mount

- Using a soft-faced mallet, carefully tap the lower bracket -1- from the transmission mount -2-.

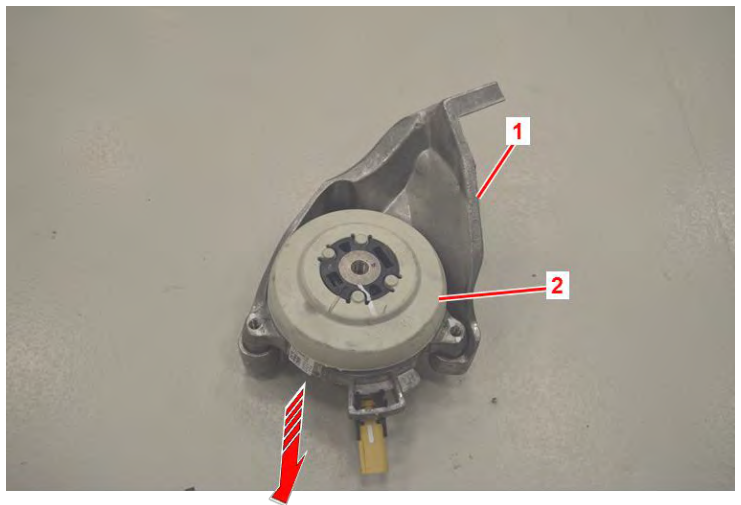

#### Installation – LH side

Installation is the reverse of removal procedure, noting the following.

#### **Caution**

When refitting the transmission mounting bracket -1-, the mounting bracket MUST be positioned to the corresponding markings previously made prior to tightening the fixings -arrows-.

- Refit all previously removed components.
- Torque tighten all remaining fixings. → Rep.-Gr.00

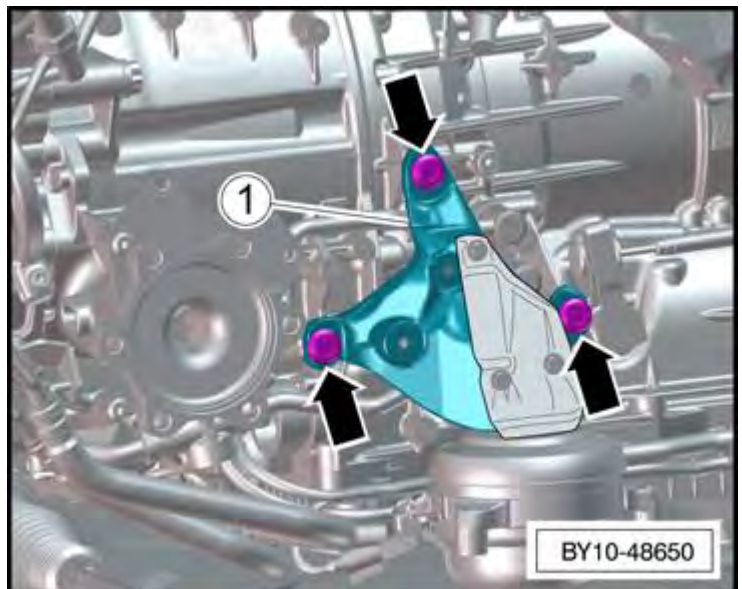

### Removal — RH side

Remove the front road wheels. Refer to

- "Road wheel - To remove and fit".

→ Rep.-Gr.44

- Remove the front undersheets -2 & 3-.

Remove the front subframe brace. Refer to

- "Brace front subframe - To remove and fit". →

Rep.-Gr.40

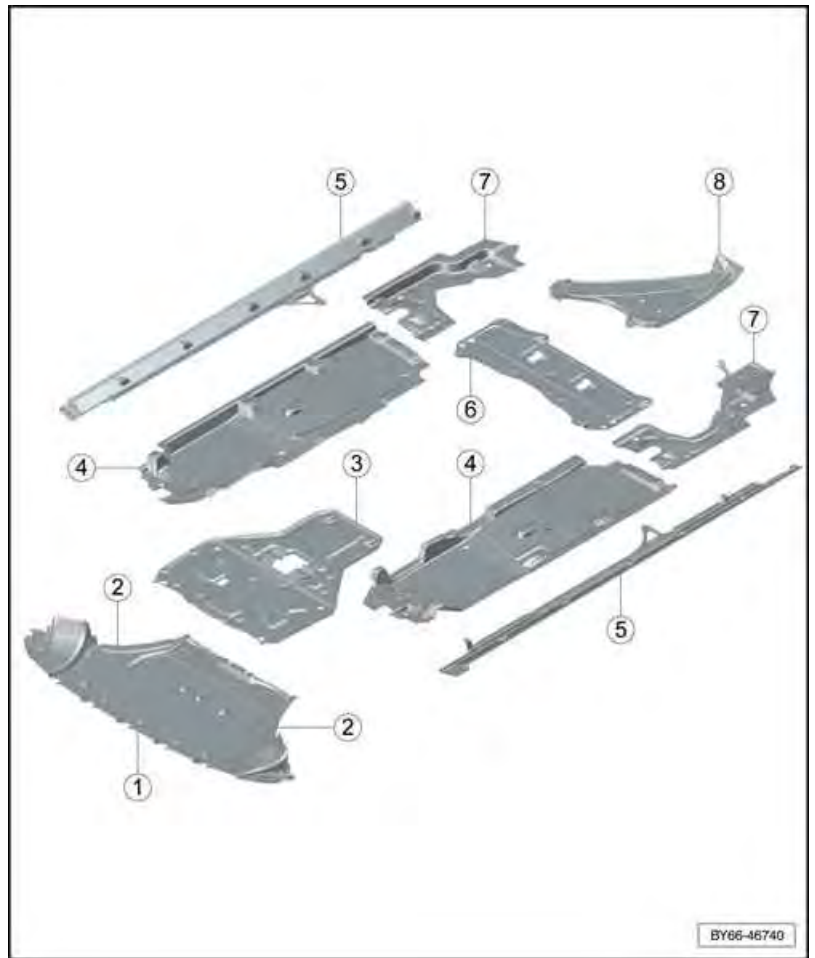

For vehicles equipped with "EAWS", remove the two fixings -arrows- (10 Nm), detach the 48 volt steering connector block -1- from the body and move to one side.

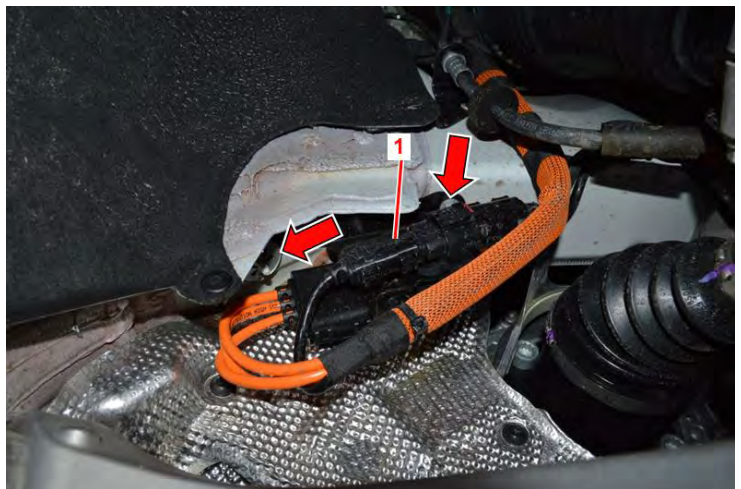

Remove the three fixings -arrows- (10 Nm) and the upper heatshield -1-.



Remove the fixing -1- from lower steering coupling (20 + 90).

Detach the steering column -2- from the rack -3- and push upwards to gain access to the transmission mount fixings.

Detach the electrical connection -arrow- to the transmission mount.

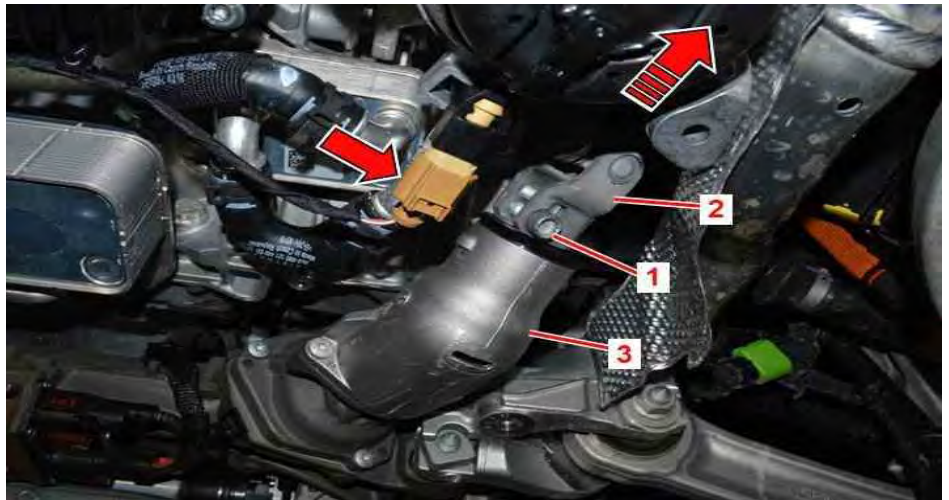

 **Caution**

Prior to removing ANY of the fixings -arrows-, mark the position of the transmission mounting bracket -1- against the automatic transmission housing in order to retain the correct height settings of the bracket -1-. Failure to do so will result in premature mount failure!

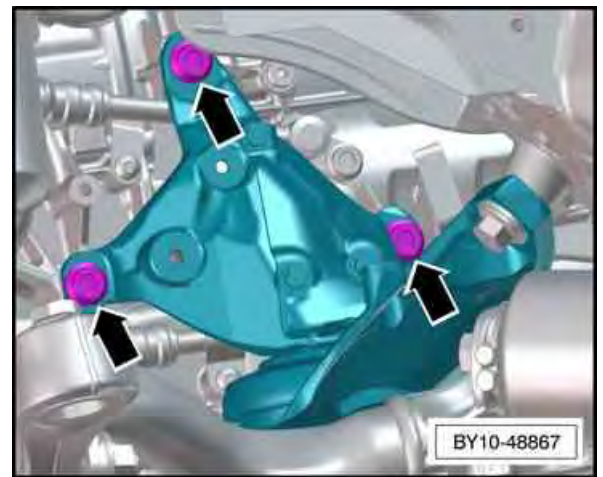

From the underside of the vehicle, remove the rearmost fixing -arrow- (20 Nm) from the transmission mount -1-.



Remove the two fixings -1- (20 Nm) securing the transmission mount -2-.

Remove the outer fixing -3- (55 Nm) securing the transmission mount -2- to the body.

Carefully manoeuvre the transmission mount assembly out from beneath vehicle.

**i** Note

*Access is tight.*



#### Replacement of the transmission mount

Remove the three fixings -arrows- (10 Nm) and the heatshield -1-.

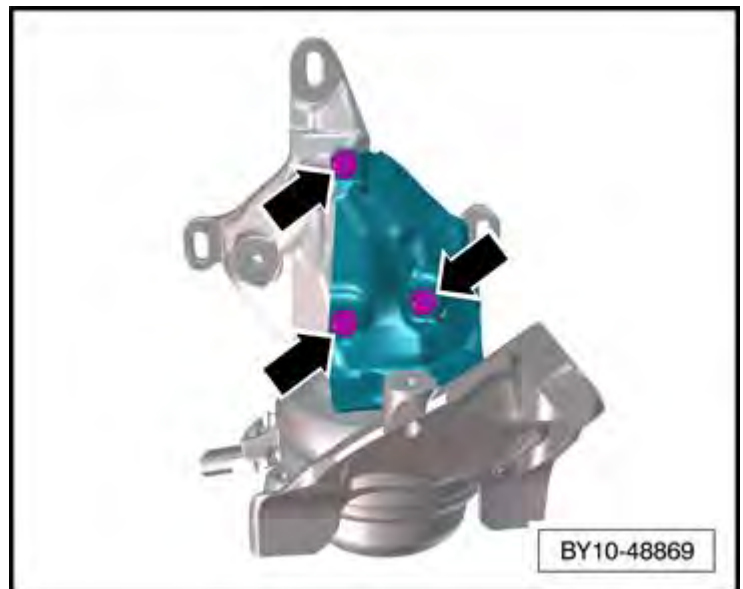

Remove the "Multispline" fixing **-arrow-** (55 Nm) and detach the top bracket.

Using a soft-faced mallet, carefully tap the lower bracket from the transmission mount.

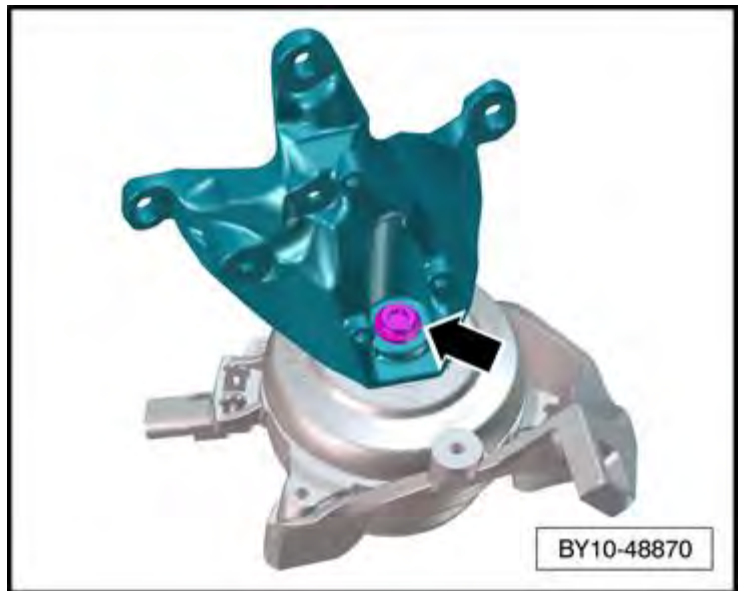

### Installation – RH side

Installation is the reverse of removal procedure, noting the following.



When refitting the transmission mounting bracket, the mounting bracket **MUST** be positioned to the corresponding markings previously made prior to tightening the fixings **-arrows-**.

- Refit all previously removed components.
- Torque tighten all remaining fixings. → [Rep.-Gr.00](#)

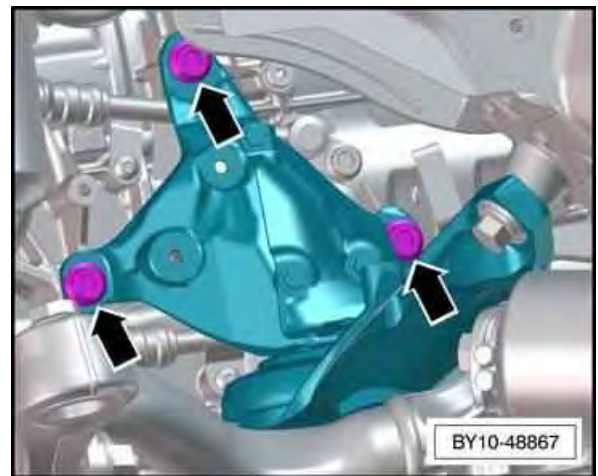

# Kovomo and Diesel Lower suspension lever - Rear - To remove and fit

## General Information

The following procedure is for the LH lower rear lever. The procedure for the RH lever is the same except where stated.

## Special tools and workshop equipment required

- ◆ Ball joint puller -T10444-

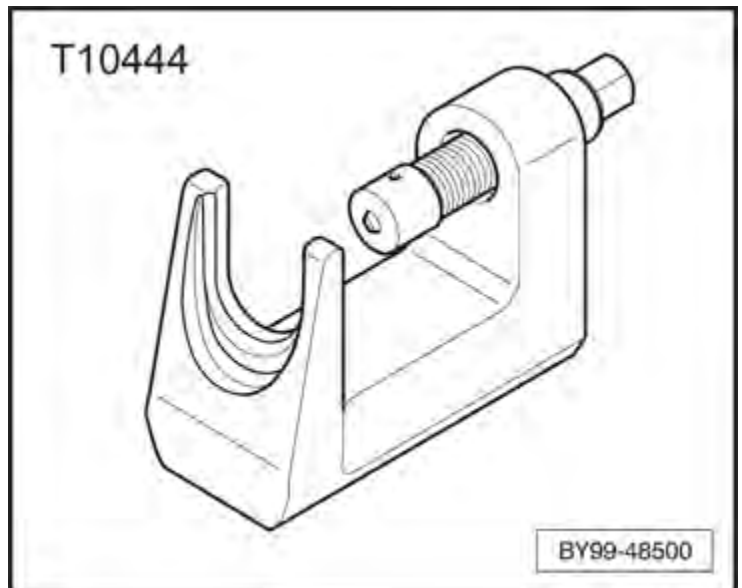

- ◆ Vehicle tester

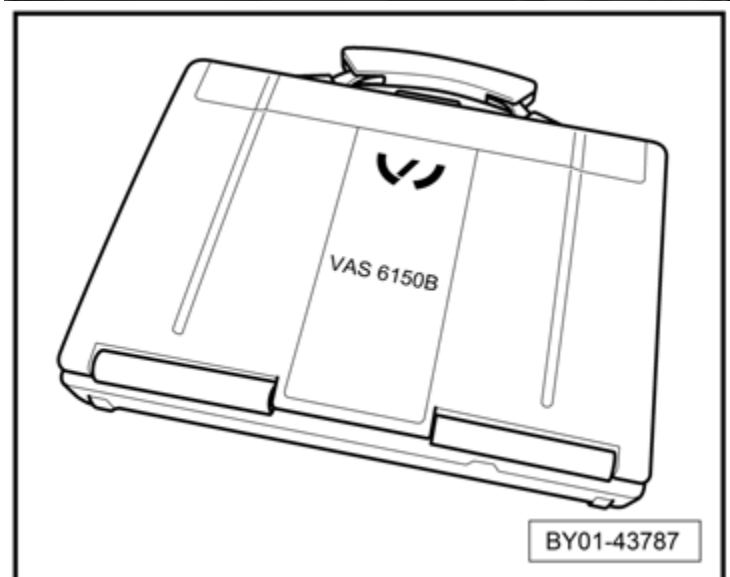

- ◆ 21 mm Ring insert -VAG 1332/7-

### Torque tightening values

Unless otherwise shown, standard torque values apply.

→ [Rep.-Gr.00](#)

### Single use items

Within this procedure there are single use items which must be replaced and not reused. Ensure that new replacements are available prior to starting this procedure.



### Removal

Set the car in "Jack" mode and position on a ramp.

- Refer to "Raising and supporting the car". → [Rep.-Gr.99](#)

Discharge the air from the air spring dampers.

- Refer to "Air suspension system - To discharge and charge". → [Rep.-Gr.43](#)



### Caution

Ensure the air is evacuated from the suspension strut prior to carrying out this procedure. The air

- ◆ is under high pressure and must only be discharged via the Vehicle tester.

Once the air has been discharged from the air suspension struts, the car must NEVER be lowered and allowed to rest on its wheels and

- ◆ compressing the discharged air suspension struts. Failure to comply may result in internal damage of the air bellows leading to catastrophic failure of the air suspension strut.

- Remove the foremost under sheet. Refer to "Front undersheets - To remove and fit". → [Rep.-Gr.66](#)

Remove the foremost transmission mount

- assembly. Refer to "Automatic transmission mounts - Front - To remove and fit ". → [Rep.-Gr.37](#)

Remove the fixings -**arrows**- (10 Nm) and detach the heatshield -**2**-.

**i** Note

The LH side has an additional coolant pipe stay bracket -**1**-. Remove this fixing also where applicable -**arrow**- (10 Nm).

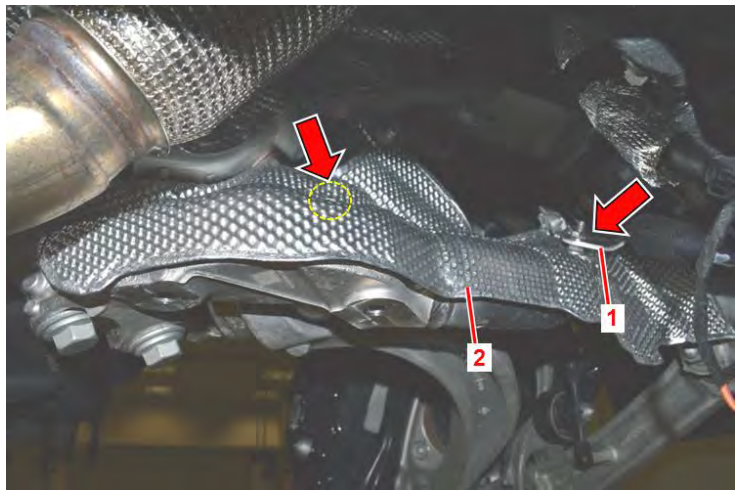

On the outer section of the lower lever and using 21 mm Ring insert -VAG 1332/7-, release the nut -**arrow**- (140 Nm) until it is flush with the end of the thread of the ball joint.

Using Ball joint puller -T10444-, "break" the taper pin of the ball joint.

Remove the Ball joint puller -T10444-, remove and DISCARD the nut -**arrow**-.

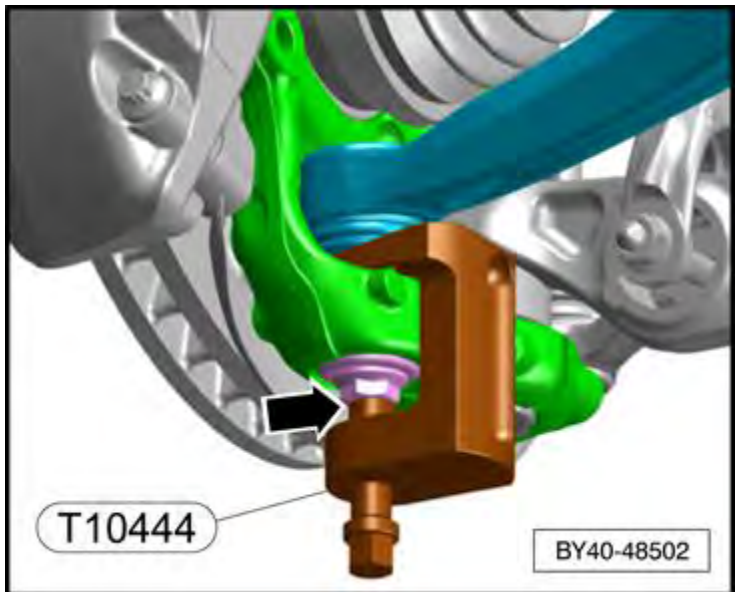

Remove and DISCARD the fixings -**2 and 3**- (70 Nm + 180°).

Manoeuvre the lower lever -**1**- out from the sub frame and wheel bearing housing.

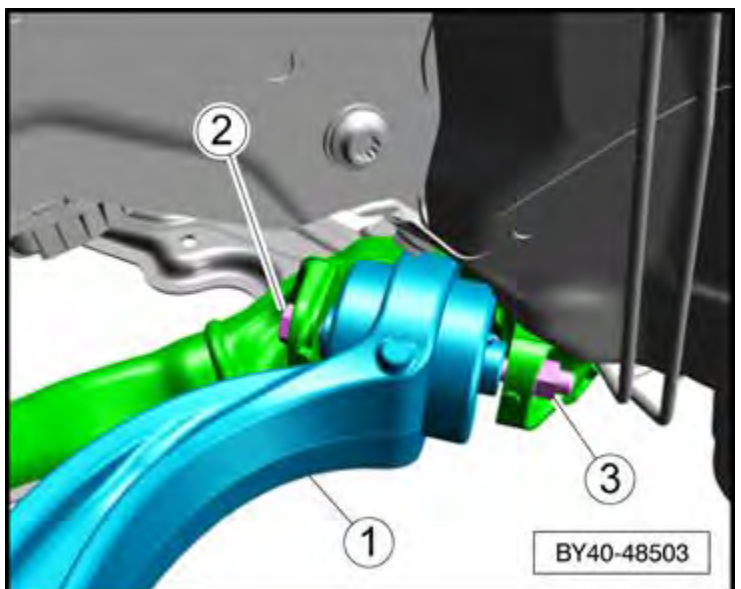

## Installation

Installation is the reverse of removal procedure, noting the following.

### Note

The lower lever -1- MUST be fitted into the wheel bearing housing first.

- Secure the outer section of the lower lever -1- to the wheel bearing housing with a NEW fixing -arrow- but do NOT yet torque tighten.

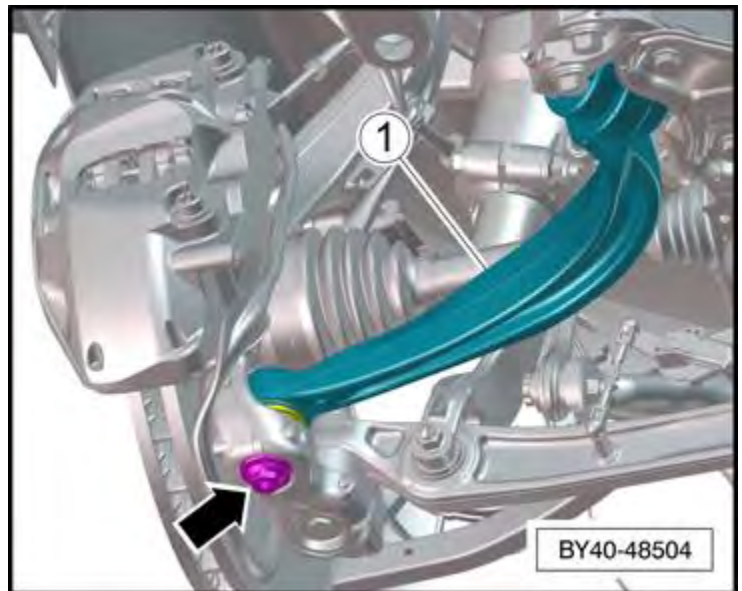

- Secure the inner section of the lower lever -1- to the sub frame with NEW fixings -2 and 3- but do NOT yet torque tighten.

### Caution

There is a requirement that any suspension component with bonded rubber bushes, all levers and the bearing housing MUST be set at standard ride height before tightening the fixings.

Bonded rubber bushes can only be turned to a limited extent. The suspension mountings must therefore only be tightened when the suspension is in the unladen position or normal level.

Failure to comply will result in the lever bushes undertaking excessive torsional twist, resulting in rupture and complete failure of the rubber inserts.

The suspension must be set to a specific angle prior to torque tightening the fixings.

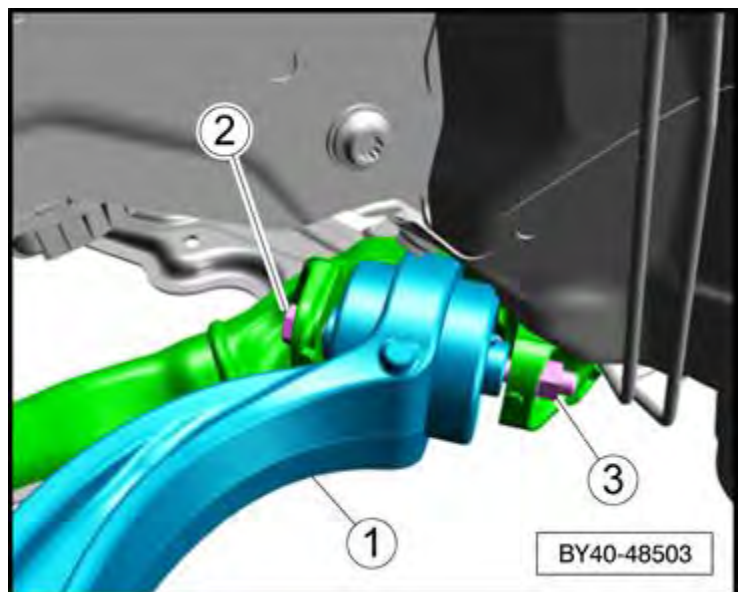

- Position the Hydraulic support stand - ASE40611000000 or VAG 1383-A- beneath the wheel bearing housing and jack until the suspension levers are at the correct ride height level. Refer to "Raising the wheel bearing housing - To tighten bolts". -> [Rep.-Gr.40](#)

With the wheel bearing housing in the raised

- position, torque tighten the fixing -3- to 70 Nm + 180 ° using a suitable "crow ring" spanner.

Remove the Hydraulic support -ASE40611000000 or VAG 1383-A-

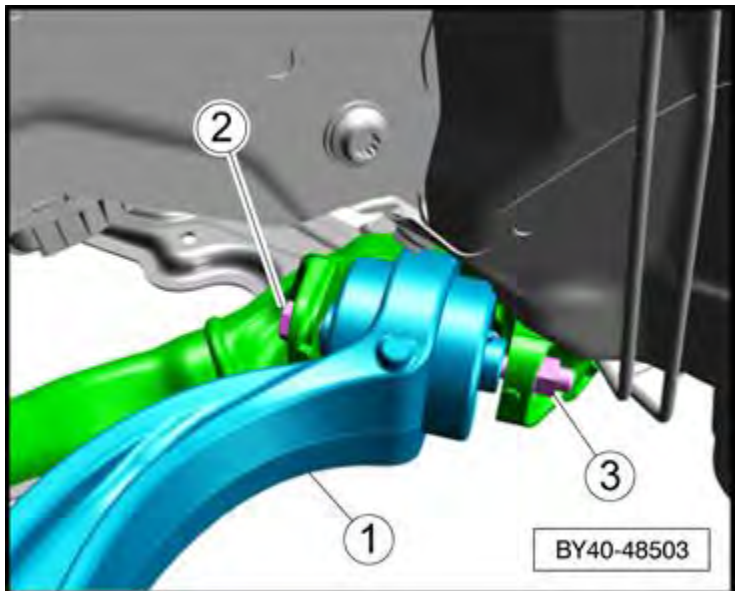

Using 21 mm Ring insert -VAG 1332/7- , torque tighten the nut -arrow- securing the ball joint on the outer section of the lower lever -1- to the wheel bearing housing to 140 Nm.

- Take the car out of "Jack" mode.→ [Rep.-Gr.99](#)
- Charge the air suspension. Refer to "Air suspension system - To discharge and charge".→ [Rep.-Gr.43](#)

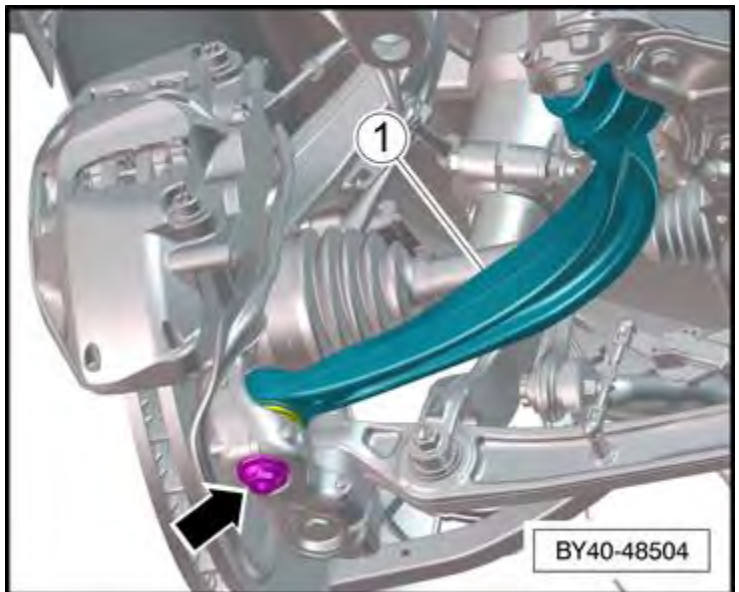

## Lower front suspension lever (rear) bush - To replace

### General Information

#### Bush — Lower suspension lever rear — To remove and fit

- Removing and installing bonded rubber bush for guide link

#### Special tools and workshop equipment required

- ◆ Thrust plate — VW 402

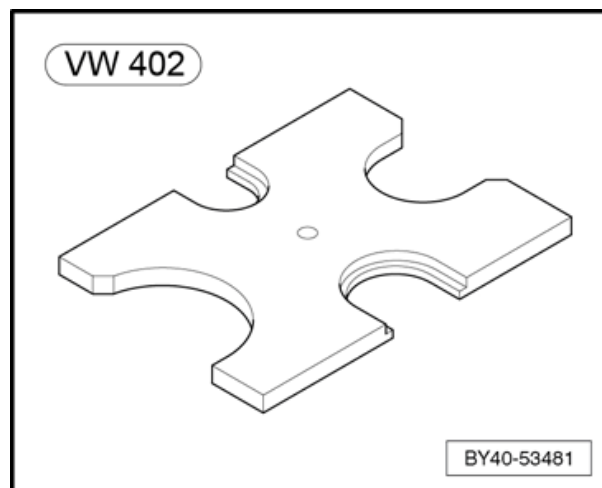

- ◆ Press tool — VW 412

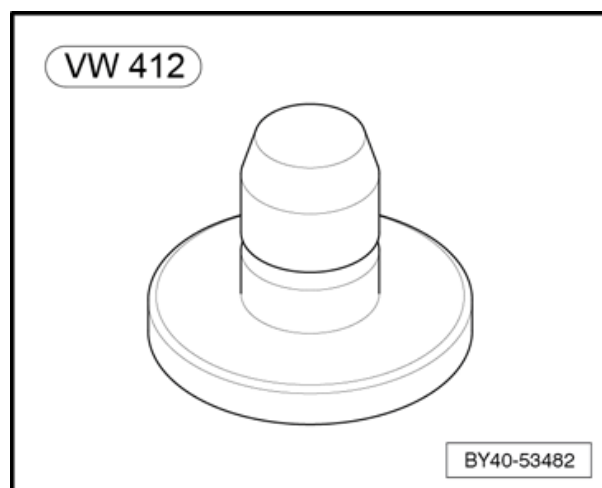

- ◆ Removal sleeve
- ◆ Workshop press VAS 6654
- ◆ Assembly lubricant -G 294 421 A1-



### Removal

- Remove rear lower suspension lever. Refer to "Lower suspension lever — Rear — To remove and fit". → [Rep.-Gr.40](#)
- Mark installation depth on bonded rubber bush using a waterproof felt-tip pen or similar.
- Set up special tools as shown in illustration
- ◆ -1- Workshop press -VAS 6654
- ◆ -2- Press tool guide
- ◆ -3- Suitable spacer
- ◆ -4- Press tool T40048/7
- ◆ -5- Bonded rubber bush
- ◆ -6- Suspension arm
- ◆ -7- Separating device VAS 251413

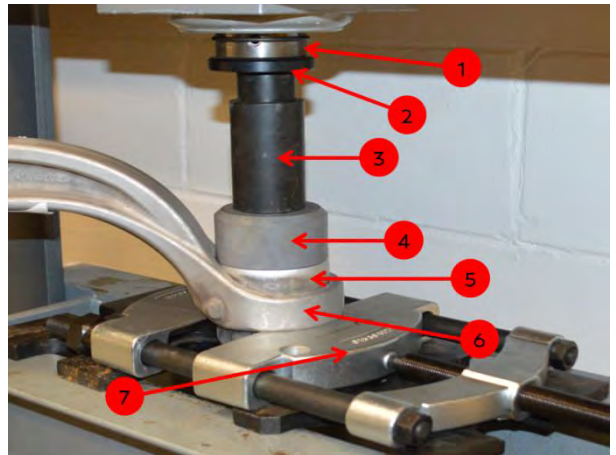

**i** Note

*Hold the suspension arm when pressing the bonded rubber bush in or out.*

- Press bonded rubber bush out of guide link.

### Installation

Installation is the reverse of removal procedure, noting the following.

- Transfer marking for installation depth from old bonded rubber bush to new bush.
- Lightly lubricate new bush with assembly lubricant.

### Installation position of bonded rubber bush

- Notch -1- should be parallel with guide link and should point inwards towards guide link.

- Arrow **-2-** points inwards towards guide link.
- Fit bonded rubber bush into guide link using previous setup of special tools.
- Press bonded rubber bush into guide link, taking care to keep it straight.
- Use marking made before removal **-arrow-** as a guide.

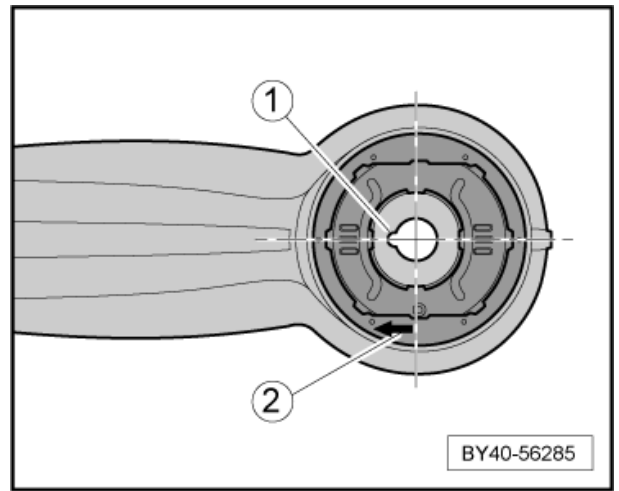

- Check installation depth **-a-** of bonded rubber bush in guide link.

**i** Note

Dimension **-a-** = 23 mm

- Press bonded rubber bush in further if specification is not met.
- Refit rear lower suspension lever.

