

# IMPORTANT UPDATE

**JOB AID  
FOR  
SPECIAL SERVICE CAMPAIGN K0B  
MILLIMETER WAVE RADAR SENSOR**

**CERTAIN:  
2018 – 2019 TACOMA  
2018 – 2019 TUNDRA**

## **VEHICLES WITH MODIFICATIONS**

**Update 5/29/2019: Modified Vehicle Labels are now available (p. 40)**

The repair quality of covered vehicles is extremely important to Toyota. All dealership technicians performing this recall are required to successfully complete the most current version of the E-Learning course “Safety Recall and Service Campaign Essentials”. To ensure that all vehicles have the repair performed correctly; technicians performing this recall repair are required to currently hold at least one of the following certification levels:

- Certified Technician (any specialty)
- Expert Technician (any specialty)
- Master Technician
- Master Diagnostic Technician

It is the dealership’s responsibility to select technicians with the above certification level or greater to perform this recall repair. Carefully review your resources, the technician skill level, and ability before assigning technicians to this repair. It is important to consider technician days off and vacation schedules to ensure there are properly trained technicians available to perform this repair at all times.

# I. OPERATION FLOW CHART

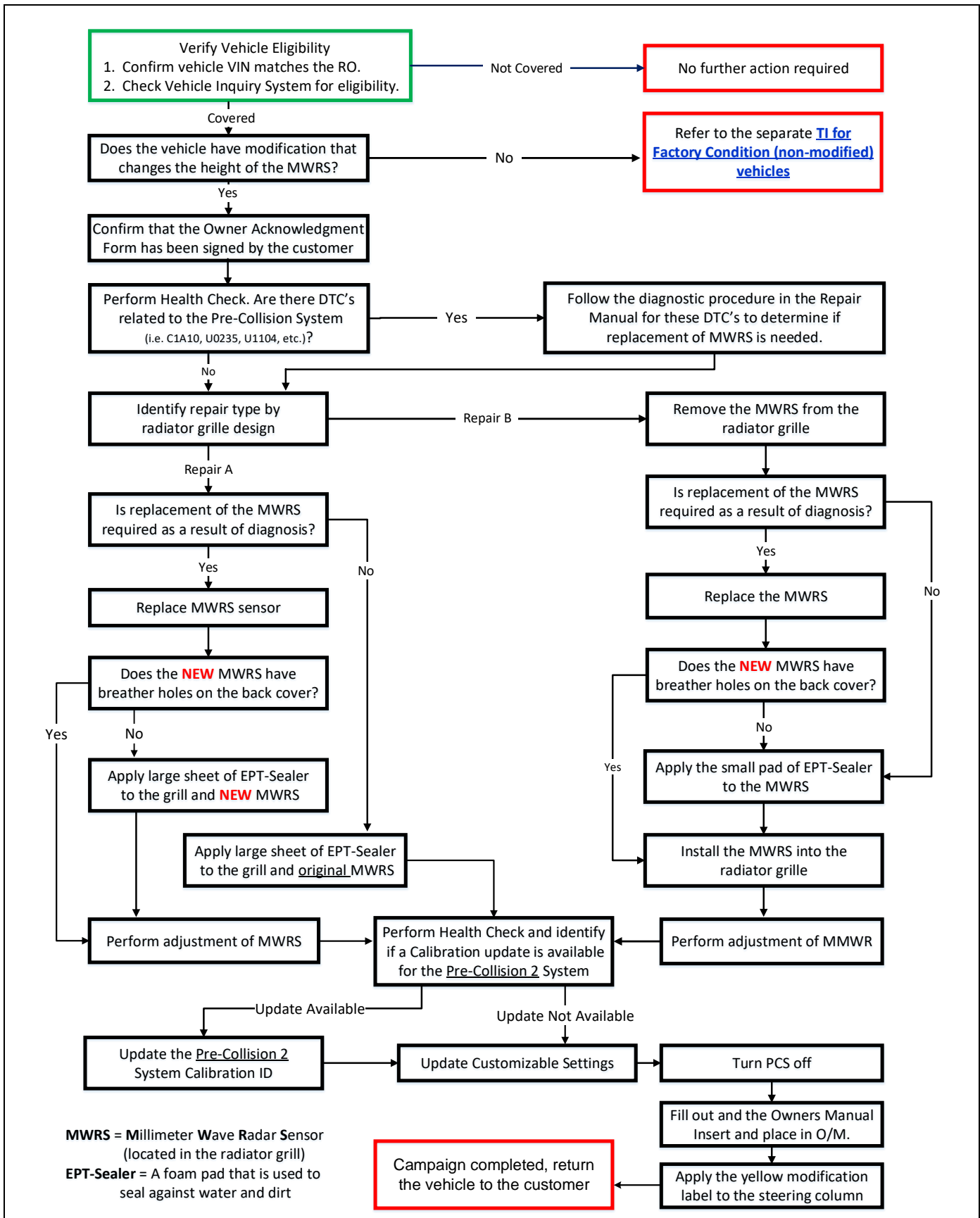

## II. PREPARATION

### A. PARTS

#### Repair A:

Part Number	Part Description	Quantity
88278-0C010	Cushion, Skid control Computer (EPT Sealer Repair A: 75 mm x 150 mm, t = 5 mm)	1
214182323	K0B Modified Vehicle Label*	1

#### Repair B:

Part Number	Part Description	Quantity
88278-0C020	Cushion, Skid control Computer (EPT Sealer Repair B: 46 mm x 32 mm, t = 3 mm)	1
214182323	K0B Modified Vehicle Label*	1

\*Note: K0B Modified Vehicle Labels are available through the Material Distribution Center. There are 10 labels on each sheet. Minimum order quantity is 1 sheet. Each dealership has been sent 1 sheet, addressed to the Service Manager. See page 40 for installation details.

Part Detail:

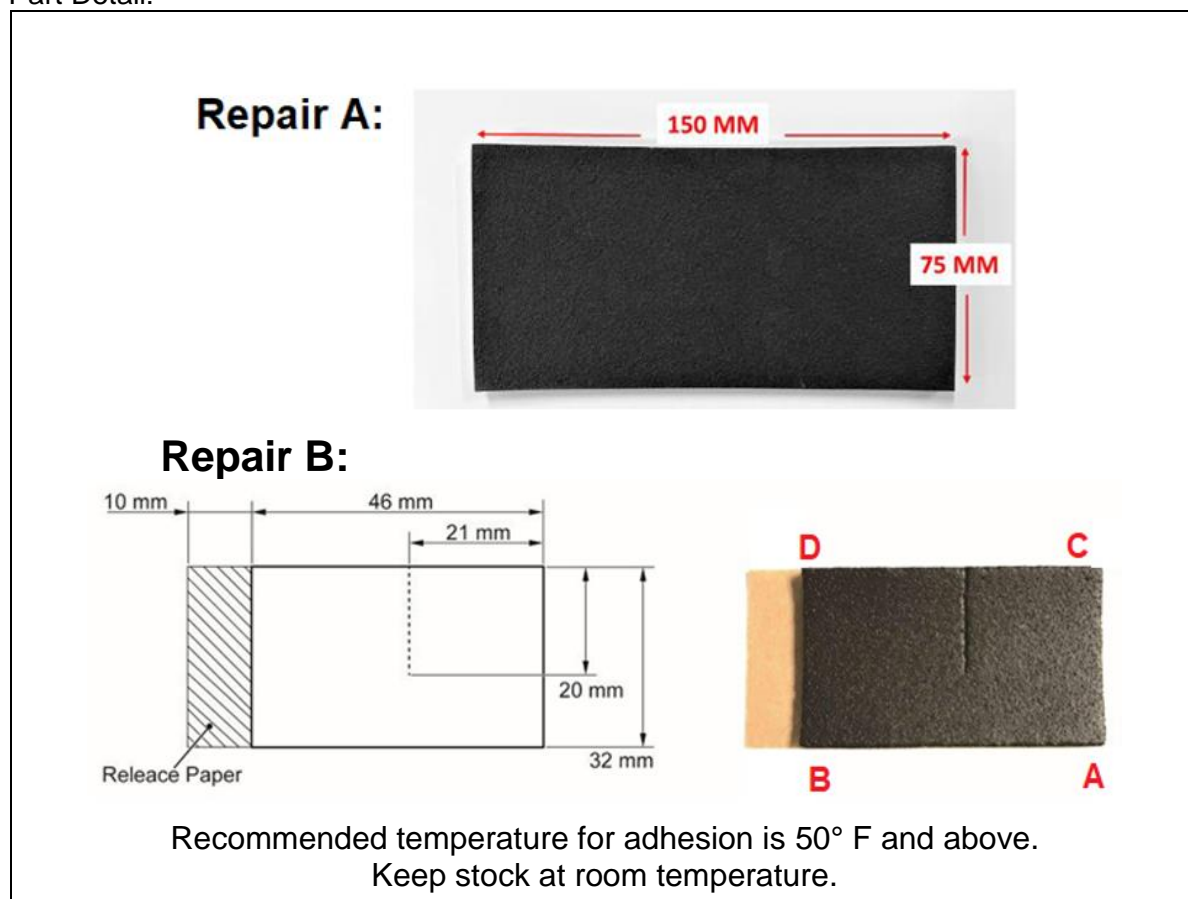

### B. TOOLS & EQUIPMENT

- Techstream
- GR8 Battery Station
- Standard Hand Tools
- Nitrile Gloves
- Torque Wrench

### C. MATERIALS

- General Purpose Cleaner

### III. BACKGROUND

The involved vehicles are equipped with a Pre-Collision System (PCS) that may automatically apply the brakes if the system detects a potential collision. Due to the mounting of one of the system's sensors, it is possible for water to enter the sensor. This can lead to PCS deactivation or inadvertent brake activation resulting in limited deceleration for a short duration of time.

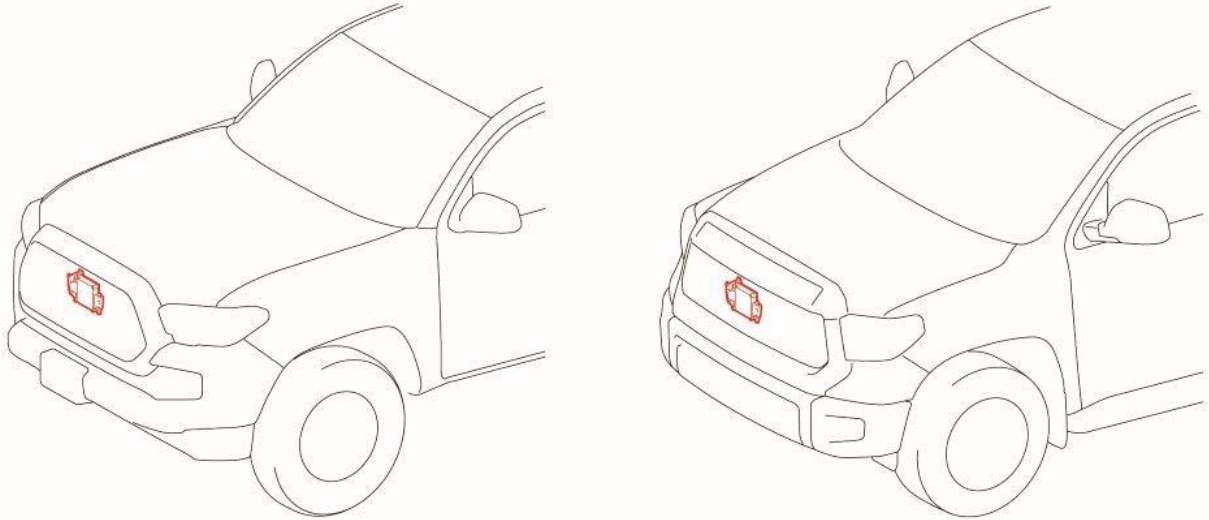

018636201007

### IV. VERIFY VEHICLE ELIGIBILITY

1. CHECK VEHICLE FOR CAMPAIGN ELIGIBILITY
  - a. Compare the vehicles VIN to the VIN listed on the Repair Order to ensure they match.
  - b. Check the TIS Vehicle Inquiry System to confirm the VIN is involved in this Campaign, and that it has not already been completed.

Note: TMNA warranty will not reimburse dealers for repairs completed on vehicles that are not affected or were previously completed, even by another dealer.

## V. CHECK FOR VEHICLE MODIFICATIONS

### 1. CHECK VEHICLE FOR MODIFICATIONS

a. Inspect the vehicle to determine if modifications have been made that changed the height of the MWRS in relation to the ground (i.e., the measurement from the ground to the MWRS).

The following are examples that will change the position of the MWRS:

- TRD grille installed in a non-TRD truck.
- Tires and/or wheel assemblies that are larger diameter than the OE fitment.
- Suspension modifications (lift kit).

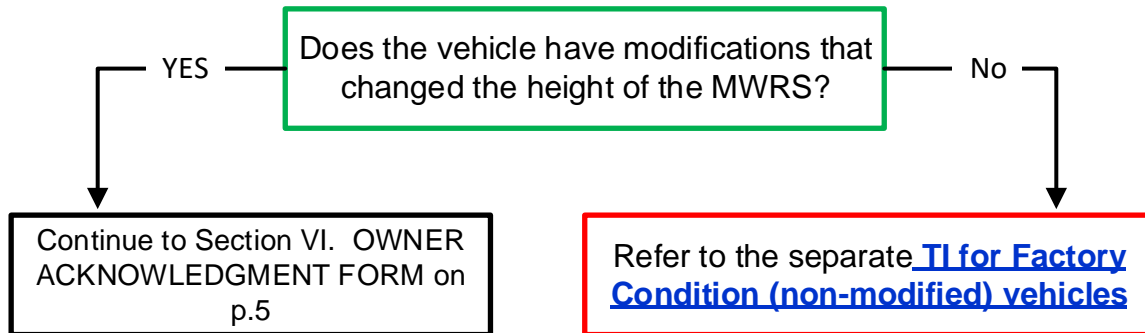

## VI. OWNER ACKNOWLEDGMENT FORM

### 1. VERIFY SIGNATURE ON OWNER ACKNOWLEDGMENT FORM

The owner of the vehicle is required to sign an acknowledgment form before any can proceed on their vehicle. This form will explain to the customer that PCS and DRCC may not operate as designed once these updates are performed on their vehicle.

a. Confirm with the Service Manager, Assistant Service Manager, Service Writer, etc. that the required Owner Acknowledgment Form as been signed before proceeding.



**If the vehicle has been modified, ensure the “Owner Acknowledgment Form” has been completed and signed by the customer before proceeding with this repair.**

## VII. CHECK FOR PRE-COLLISION SYSTEM DTC'S



### 1. CHECK FOR DTC'S

- a. Using a Techstream, perform a Health Check.
- b. Are there any DTC's relating the Pre-Collision system (i.e. C1A10, U0235, U1104) as reported by any system?

**Note:** This Service Campaign covers the application of the EPT-Sealer and Calibration ID update for the Pre-Collision 2 System, as detailed in these instructions. It will also cover the replacement cost of the Millimeter Wave Radar Sensor (MWRS), when necessary. It does not cover the diagnosis or replacement of any other parts on the vehicle.

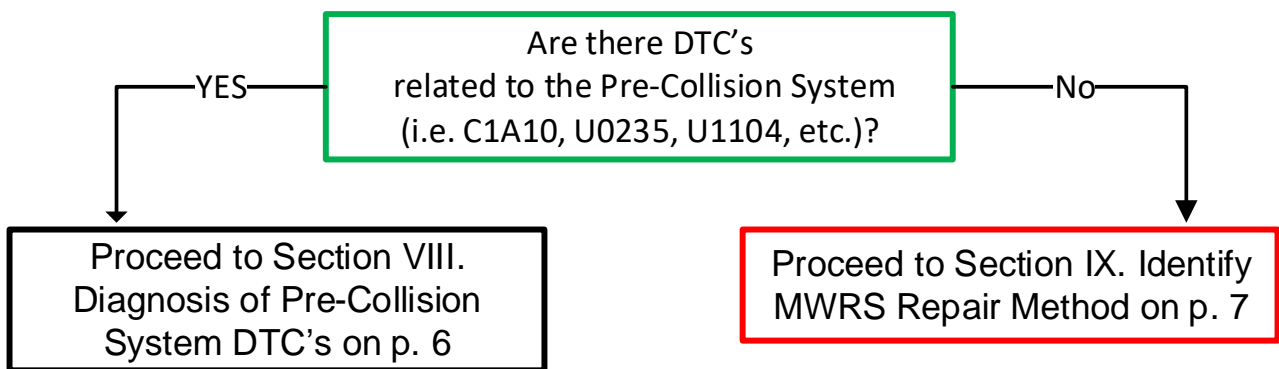

## VIII. DIAGNOSIS OF PRE-COLLISION SYSTEM DTC'S

### 1. DETERMINE THE CAUSE OF PRE-COLLISION SYSTEM DTC'S

- a. Use the appropriate Repair Manual procedure to determine the cause of the Pre-Collision System DTC's.

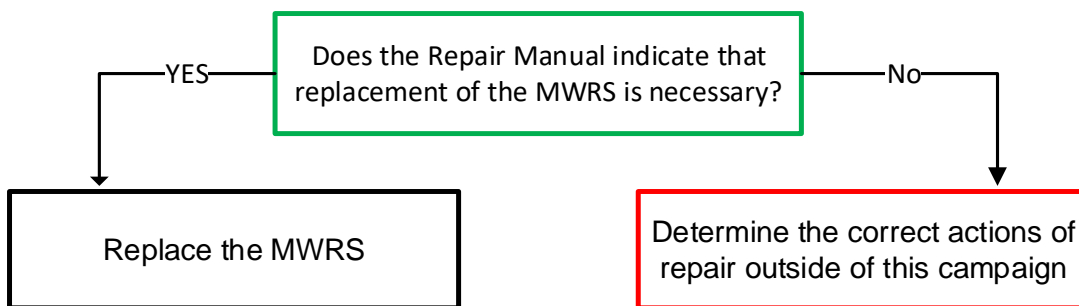

**Note:** Because there are multiple reasons that could cause Pre-Collision system failures, it's critical to diagnose the system to determine the source of the trouble. This campaign will only cover the replacement of the Millimeter Wave Radar Sensor, which is located behind the Toyota emblem of the radiator grille. If the diagnostic process identifies that the DTC's are caused by something other than the Millimeter Wave Radar Sensor, this campaign will not cover the cost associated with the repair.

**Continue to IDENTIFY MWRS REPAIR METHOD on page 7**

**IX. IDENTIFY MWRS REPAIR METHOD (A or B)**

**1. DETERMINE THE REPAIR METHOD FOR THIS VEHICLE**

a. Use the following chart, reference the trim level of each vehicle to determine which repair method to use.

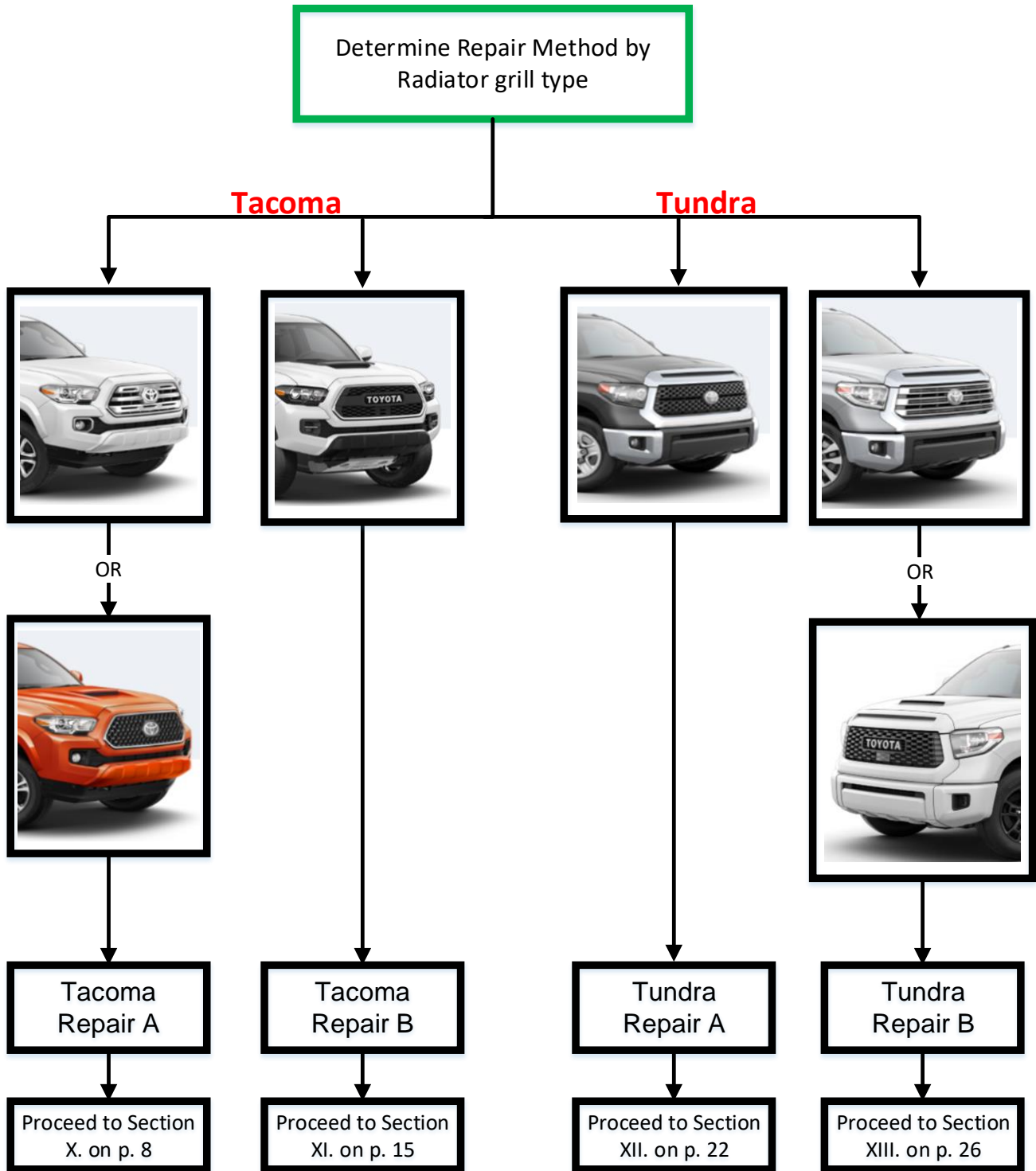

## X. TACOMA - REPAIR A

TACOMA - Repair A vehicles will have radiator grilles of these designs:

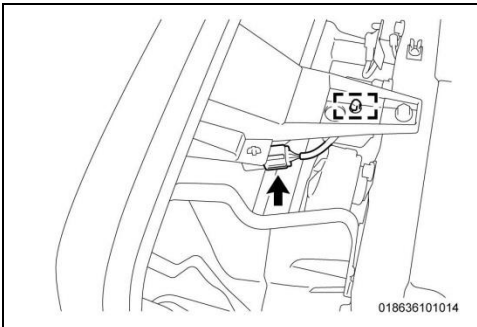

### 1. REMOVE RADIATOR GRILLE

- a. Disconnect the electrical connector.
- b. Disengage the clamp.

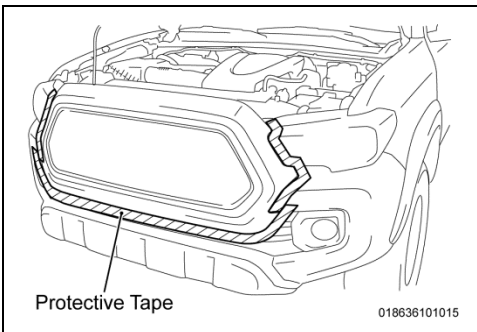

- c. Apply protective tape around the radiator grille.

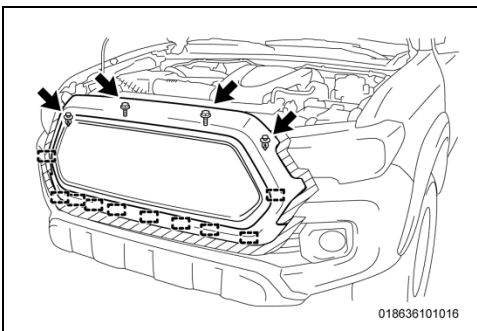

- d. Remove the 2 screws.
- e. Remove the 2 clips.
- f. Disengage the 10 guides to remove the grille.



## 2. DETERMINE IF A NEW MWRS IS REQUIRED

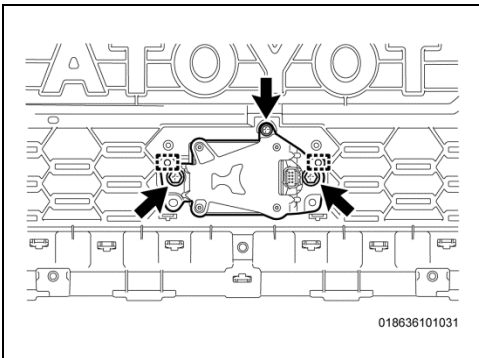
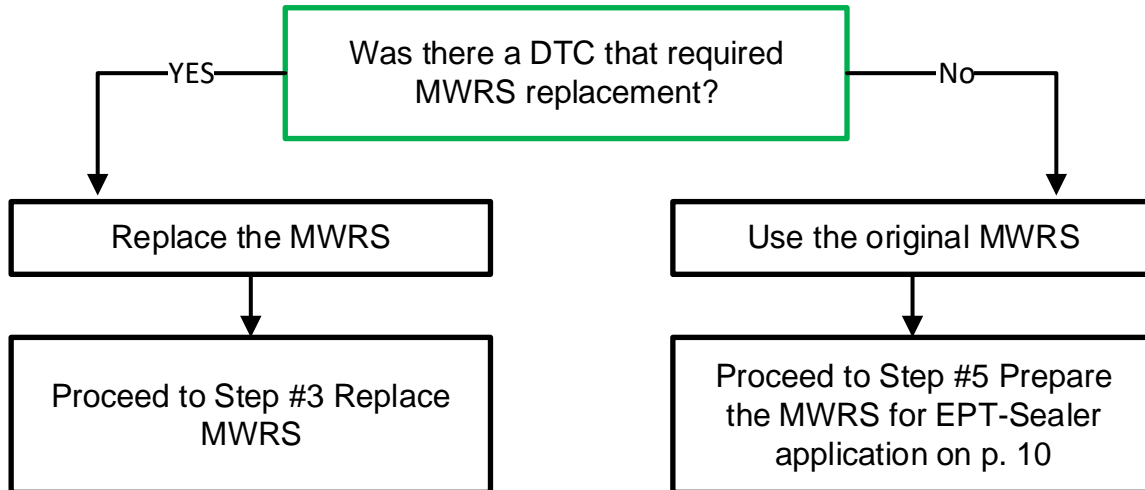

## 3. REPLACE MWRS (only if required)

- Remove the 2 bolts and screw.
- Remove the original MWRS.
- Install the **NEW** MWRS by engaging the 2 guides of the grille into the guide holes of the MWRS.
- Install the 2 bolts and screw.

**Torque: 2.5 N·m (25 kgf·cm, 22 in.lbs)**

## 4. DETERMINE IF EPT-SEALER IS NECESSARY FOR **NEW** SENSOR

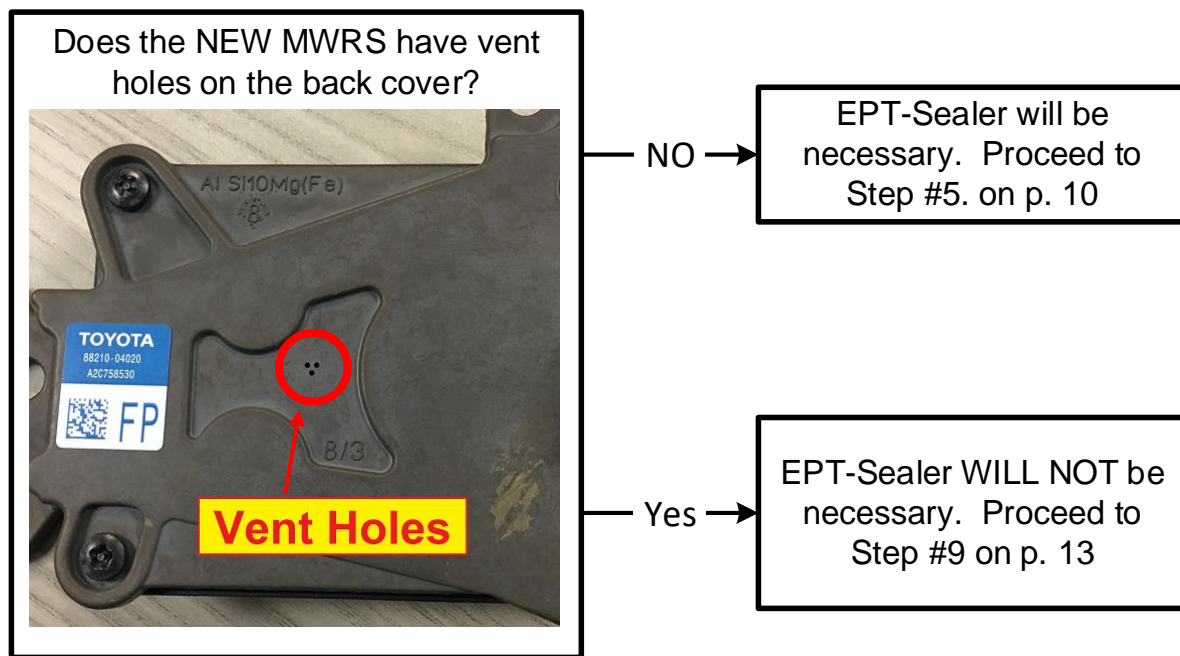

## 5. PREPARE THE MWRS FOR EPT-SEALER APPLICATION

- Place a blanket onto the table or workbench.
- Place the radiator grille onto the blanket, front side down.
- Using general purpose cleaner and a clean towel, clean the back side of the MWRS sensor and the emblem area on the back side of the grille.

## 6. DETERMINE GRILLE TYPE

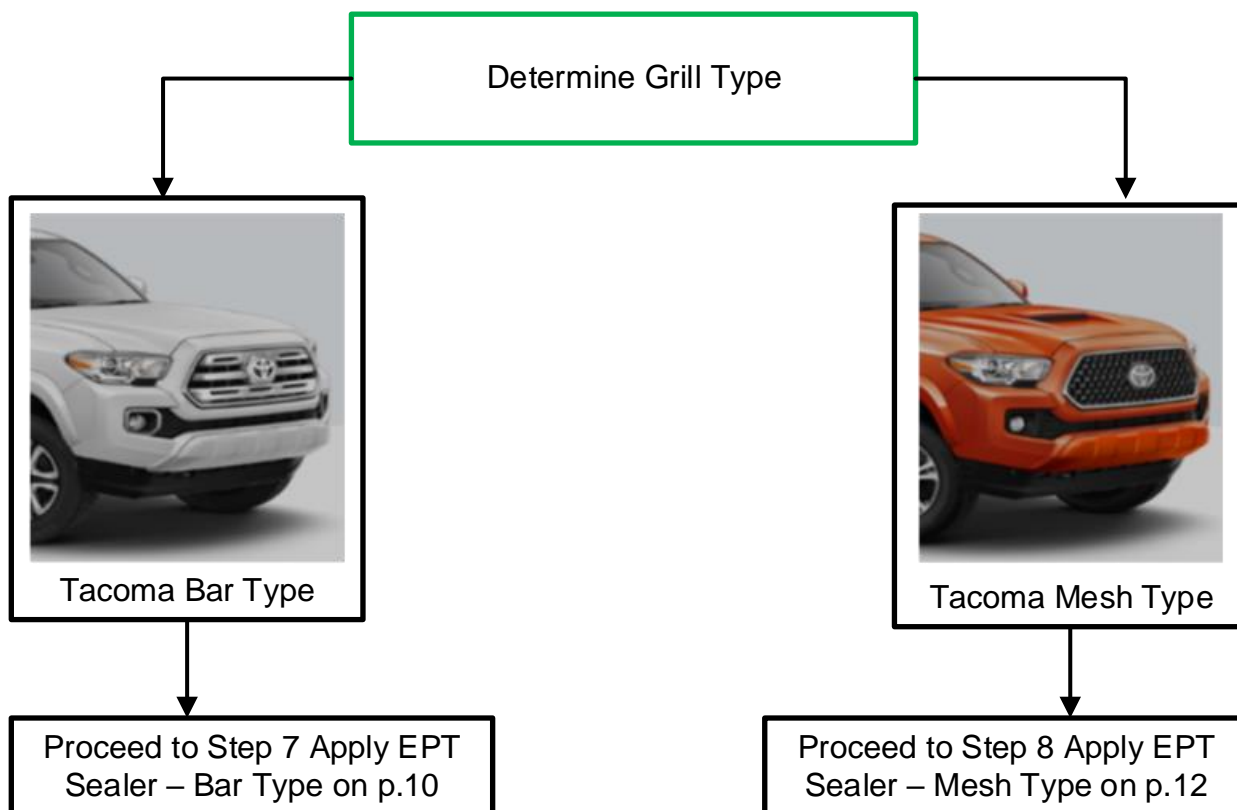

## 7. APPLY EPT-SEALER – Tacoma Bar Type

**Note:** This application will use P/N **88278-0C010**. (75mm x 150mm x 5mm)

This process is only for Tacoma's with the Bar type grille:



**Video:** Not available at this time

(cont.)

- a. Apply the EPT Sealer to the back side of the MWRS in the position shown below:
- Start applying the EPT Sealer sheet to the vertical surface of the radiator grille, just above the MWRS.
  - It will be necessary to push the EPT Sealer into the plastic tab at the top, creating a hole in the sealer.
  - Wrap the EPT Sealer around the wire harness, as shown.
  - Using heavy finger pressure, thoroughly press the entire surface of the EPT sealer to securely adhere it to all contact surfaces of the MWRS and grille.



Recommended temperature for adhesion is 50° F and above.  
Keep stock at room temperature.

**Continue to Step 9 on page 13**

## 8. APPLY EPT-SEALER – Tacoma Mesh Type

**Note:** This application will use P/N **88278-0C010**. (75mm x 150mm x 5mm)

This process is only for Tacoma's with the Mesh type grille:



### [Video: Tacoma Mesh Type Repair – EPT-Sealer Installation](#)

a. Apply the EPT Sealer to the back side of the MWRS in the position shown below:

- Start applying the EPT Sealer sheet to the horizontal lip of the radiator grille to create a waterproof shield over the top of the sensor.
- Using heavy finger pressure, thoroughly press the entire surface of the EPT sealer to securely adhere it to all contact surfaces of the MWRS.



Recommended temperature for adhesion is 50° F and above.  
Keep stock at room temperature.

## 9. REINSTALL RADIATOR GRILLE

- a. Engage the 10 guides to install the radiator grille.
- b. Install the 2 clips.
- c. Install the 2 screws.
- d. Remove the protective tape.
- e. Engage the clamp.
- f. Connect the electrical connector.

## 10. DETERMINE IF MWRS ADJUSTMENT IS NECESSARY

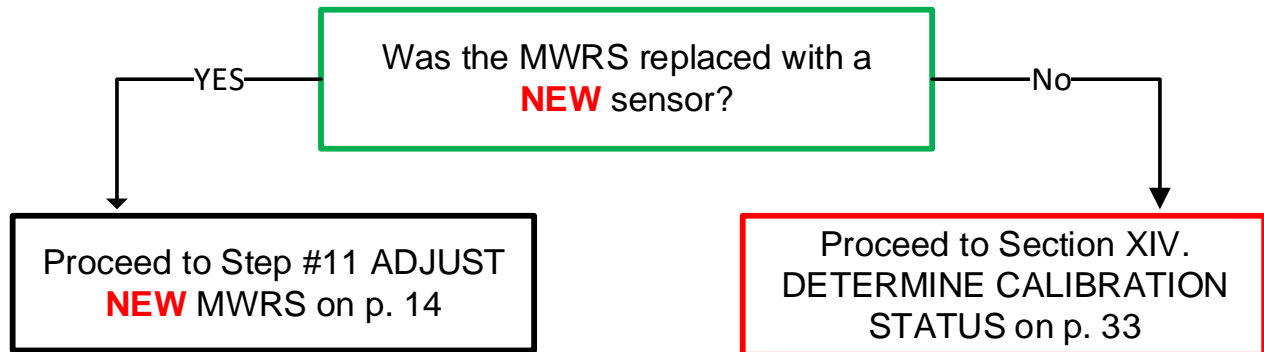

## 11. ADJUST NEW MWRS

Because the modifications on this vehicle have changed the height of the MWRS from its original condition, it will be necessary to adjust the SST reflector height to match the height of the MWRS. When following the MWRS Adjustment procedure in the Repair Manual, change the height of the SST reflector to match the center of the MWRS in the grille.

- a. Adjust the height of the SST reflector to the center of the MWRS in the grille.
- b. Follow the Repair Manual procedure to properly calibrate the MWRS:

[CRUISE CONTROL: MILLIMETER WAVE RADAR SENSOR: ADJUSTMENT](#)  
(RM1000000018991)

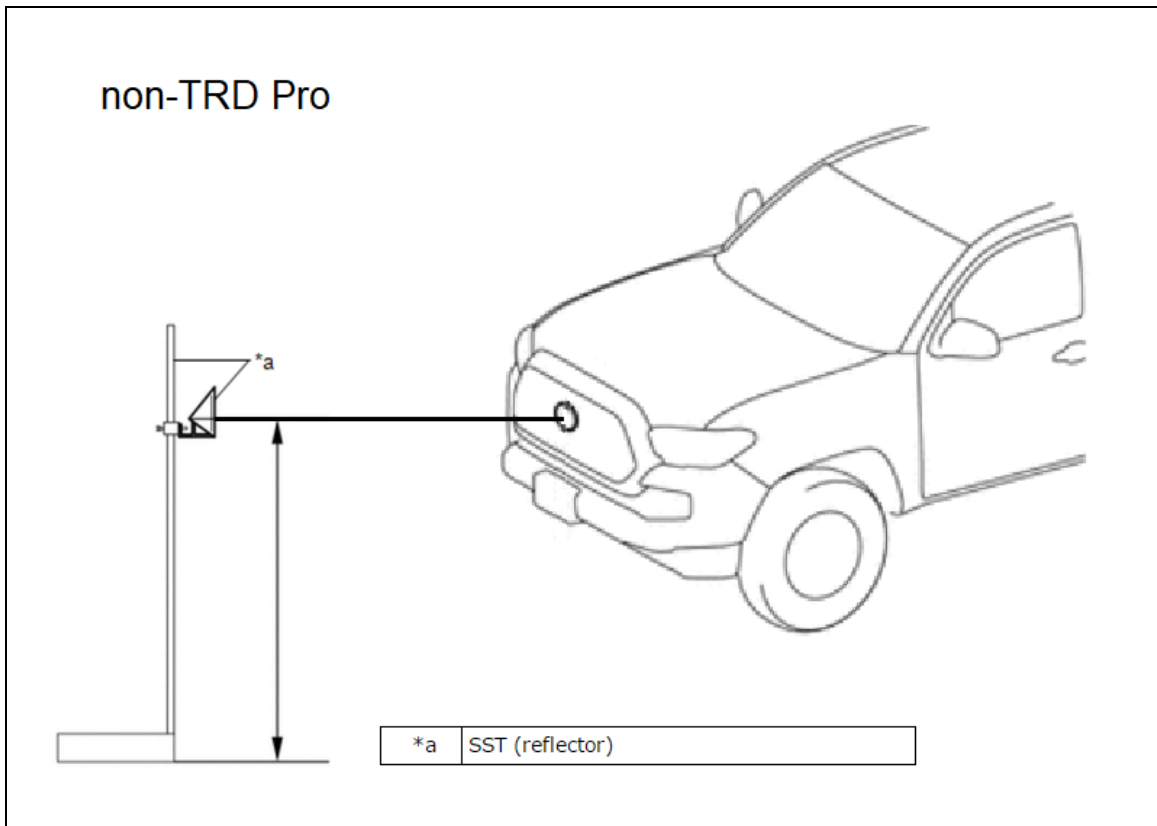

**Proceed to DETERMINE CALIBRATION STATUS on p. 33**

## XI. TACOMA - REPAIR B

TACOMA Repair B vehicles will have a radiator grille of this design:

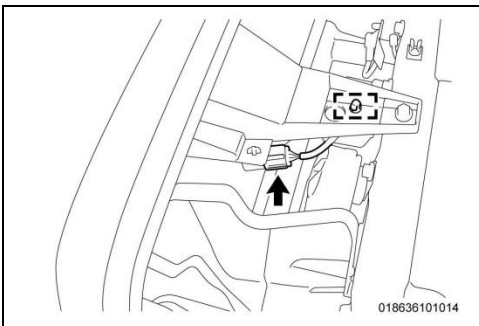

### 1. REMOVE RADIATOR GRILLE

- a. Disconnect the electrical connector.
- b. Disengage the clamp.

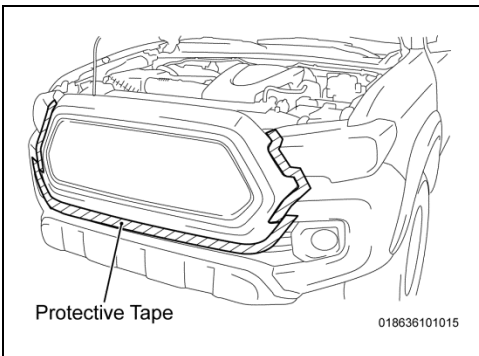

- c. Apply protective tape to the bumper around the radiator grille.

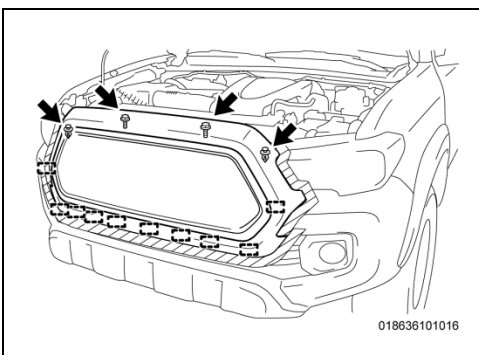

- d. Remove the 2 screws.
- e. Remove the 2 clips.
- f. Disengage the 10 guides by pulling the grille forward to disengage the remaining clips.

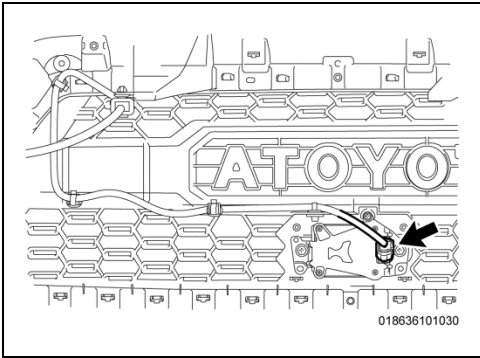

**2. REMOVE MWRS FROM THE GRILLE**

- a. Place a blanket onto a table or workbench.
- b. Place the radiator grille onto the blanket, front die down.
- c. Disconnect the electrical connector.

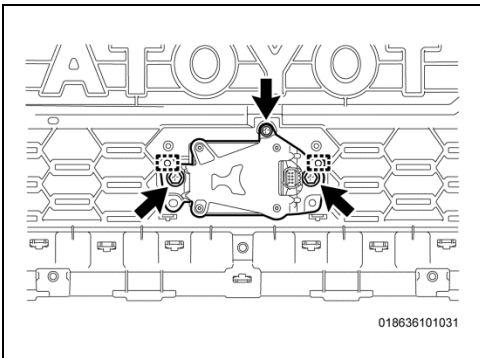

- d. Remove the 2 bolts and screw.
- e. Disengage the 2 guides and remove the MWRS from the grille.

**3. DETERMINE IF A NEW MWRS IS REQUIRED**

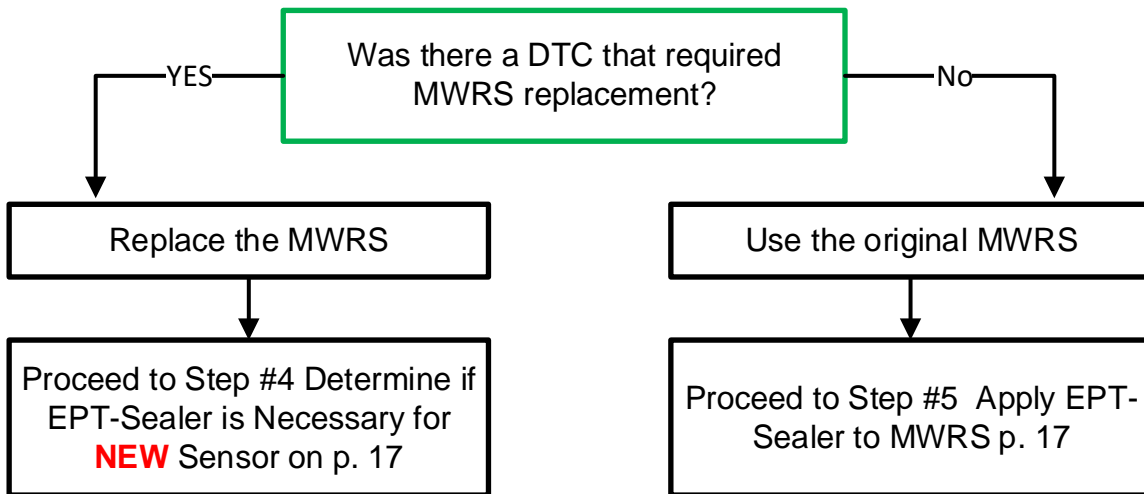



#### 4. DETERMINE IF EPT-SEALER IS NECESSARY FOR **NEW** SENSOR

Does the NEW MWRS have vent holes on the back cover?



NO → EPT-Sealer will be necessary. Proceed to Step #5. on p. 17

Yes → EPT-Sealer WILL NOT be necessary. Proceed to Step #9 on p. 20

#### 5. APPLY EPT-SEALER TO MWRS

Note: This application will use P/N **88278-0C020**. (46mm x 32mm x 5mm)

The EPT-Sealer will be applied in a specific way, using the following points for orientation. Please note the arrangement of corners A, B, C, D.

Video: [EPT Sealer Installation Repair B](#)

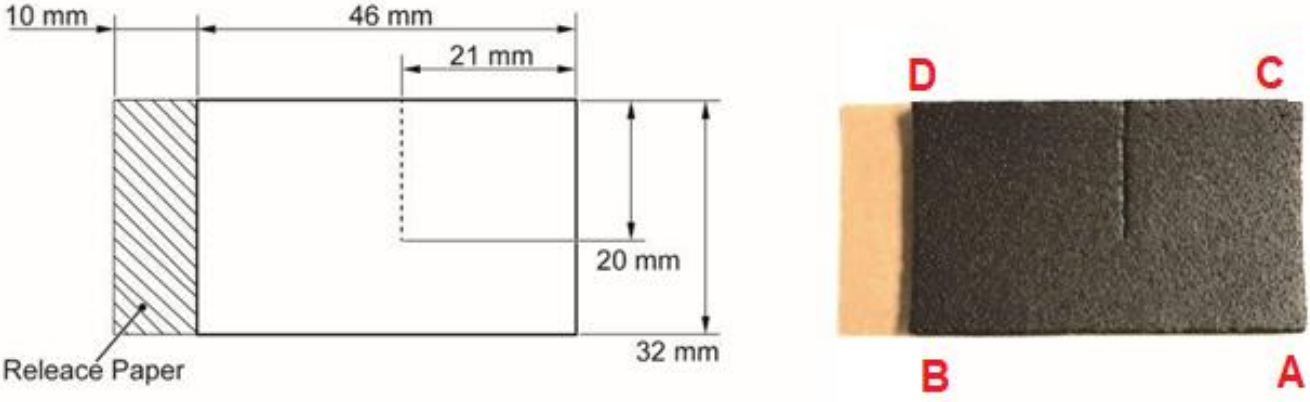

10 mm      46 mm      21 mm

20 mm      32 mm

Release Paper

D      C

B      A

Recommended temperature for adhesion is 50° F and above.  
Keep stock at room temperature.

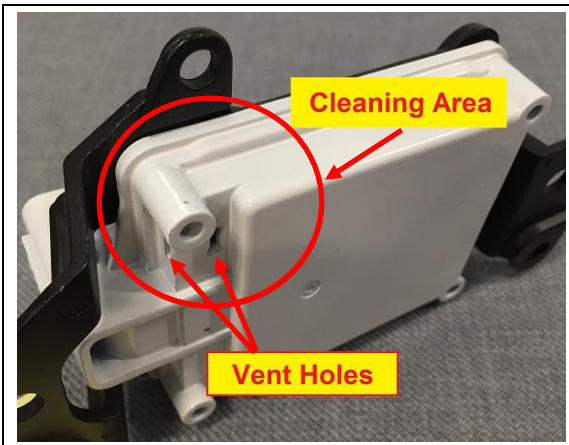

## 6. CLEAN THE APPLICATION AREA

- a. Using general purpose cleaner, remove all traces of dust, dirt, and oils or grease from the application area (indicated within the red circle). Be careful not to get any liquids into the 2 vent holes.

**Note:** The MWRS housing has been painted white in these photos to provide more contrast in the pictures. The actual MWRS housings will be black.

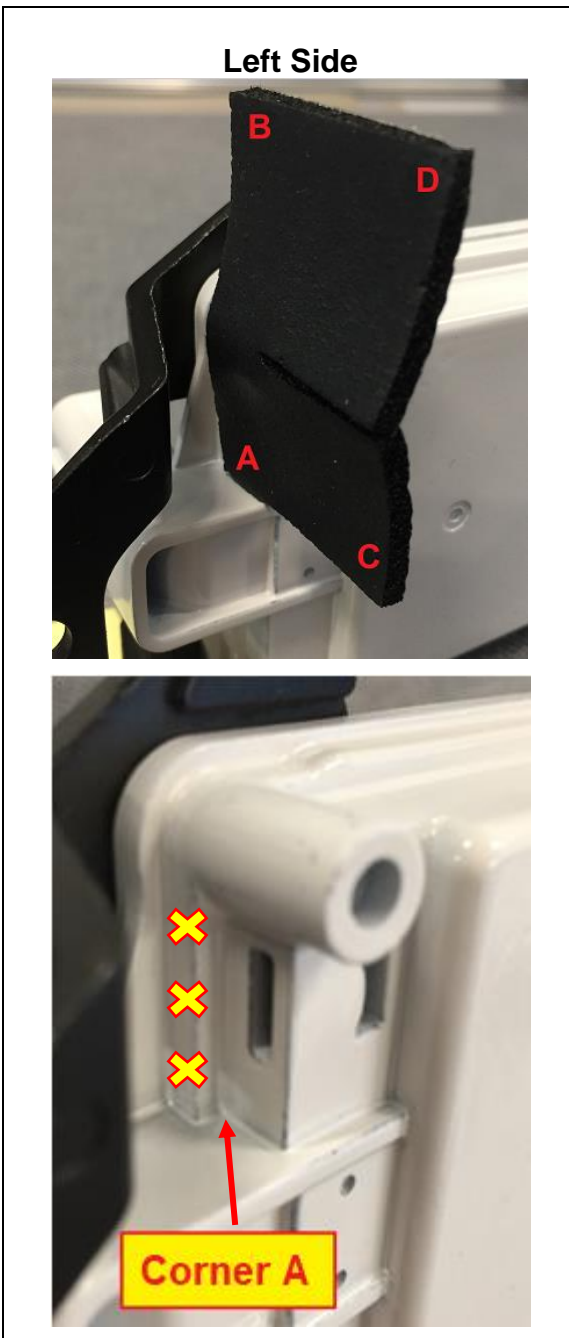

## 7. APPLY THE EPT SEALER

- a. Wear Nitrile Gloves to prevent adhesive contamination.
- b. Apply the EPT-Sealer to the left side of the MWRS to the following standard:
  - **Left Side View:** Corner “A” of the EPT-Sealer should be placed at the inner corner of the MWRS as indicated.
  - **Top View:** Place the EPT-Sealer on the surface of the side vent hole (it is ok to cover the side vent hole). **DO NOT place the EPT Sealer on top of the ridge**, as indicated with the yellow X's.

**Note:** A diagram of the EPT sealer can be found on page 14.

- c. Press the EPT sealer firmly into place in this area to seat it thoroughly. Use a flathead screw driver or trim tool if necessary to reach the corner.

### Top View

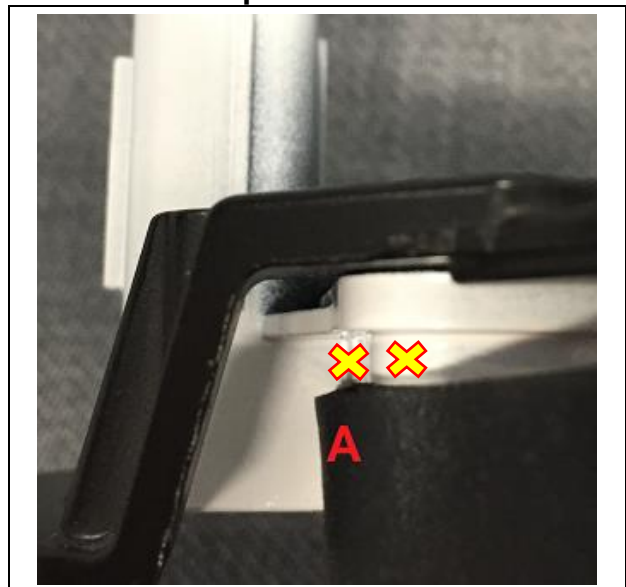

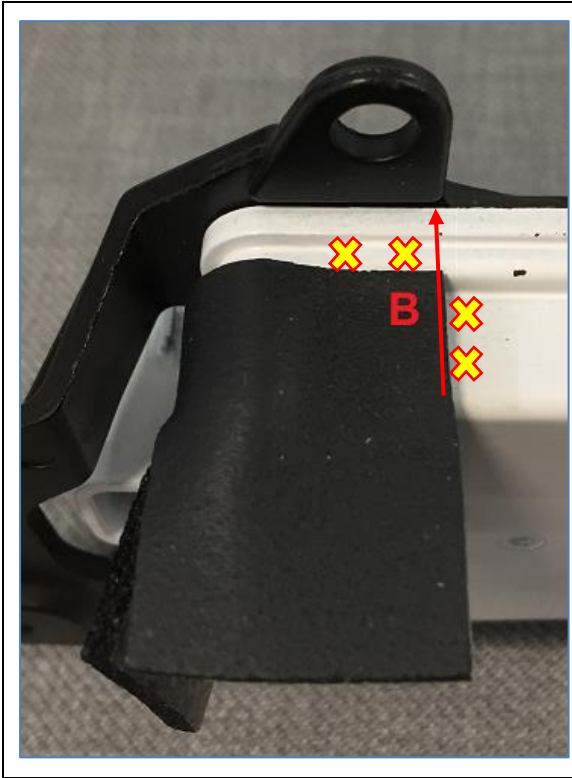

- d. Roll the EPT-Sealer Corner “B” onto the top edge of the MWRS sensor as shown, **aligning it’s edge with the end of the metal bracket. Be sure to keep the EPT-Sealer off the upper ridge.**
- e. Press the EPT sealer firmly into place in this area to seat it thoroughly.

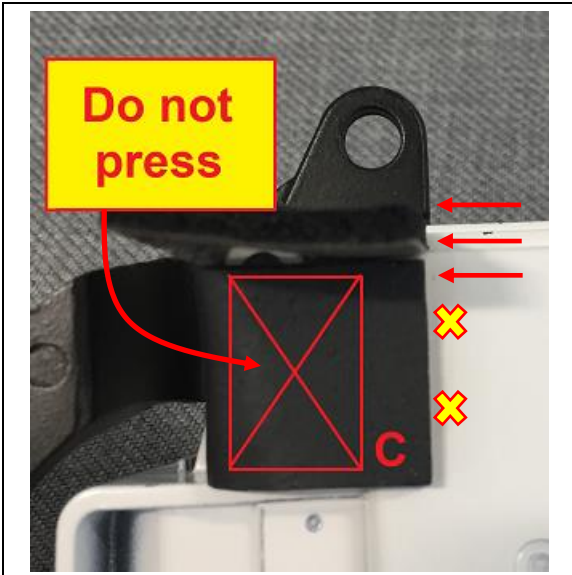

- f. Bend the lower flap (Corner “C”) onto the face of the MWRS and align the edge with the edge of the upper flap and metal bracket.
- g. Press the EPT-Sealer into the face of the MWRS to seat it firmly. **DO NOT** press in the area indicated as it’s critical there is an air gap for the vent.

	<p><b>ONLY PRESS THE EPT-SEALER ONTO THE UPPER FACE OF THE MWRS. DO NOT press the EPT sealer into the vent hole. It’s critical that the vent hole remains open.</b></p>
---	---

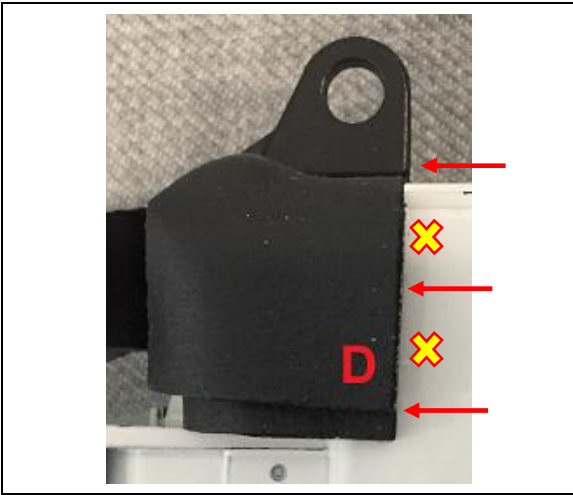

- h. Roll Corner “D” downward from the top, aligning the edge with the edge of the lower section and metal bracket.
- i. Press the EPT sealer into place, being careful to leave an airgap above the rear vent hole.

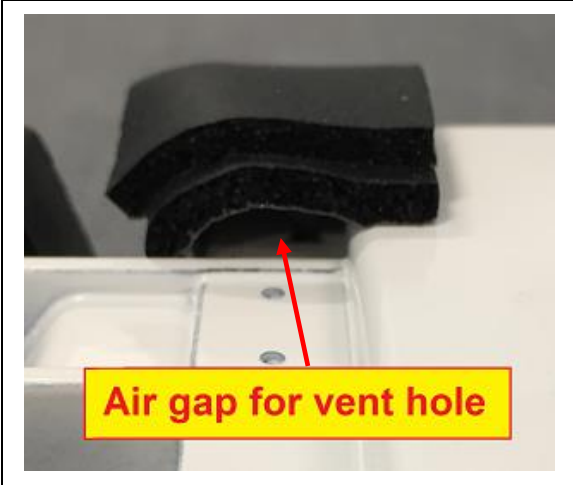

## 8. INSPECT THE EPT-SEALER APPLICATION

- a. Verify that all the contact points of the EPT sealer are thoroughly applied.
- b. **Verify that the bottom is still open to properly allow airflow to the rear vent hole.**

**Note: In case of failure during inspection, start over with a new piece of EPT-Sealer.**

## 9. INSTALL THE MWRS

- a. Engage the 2 guides of the radiator grille into the guide holes of the MWRS.
- b. Install the 2 bolts and screw.

**Torque: 2.5 N·m (25 kgf·cm, 22 in.lbs)**

## 10. REINSTALL THE RADIATOR GRILLE

- a. Engage the 10 guides to install the radiator grille.
- b. Install the 2 clips.
- c. Install the 2 screws.
- d. Remove the protective tape.
- e. Engage the clamp.
- f. Connect the electrical connector.

## 11. ADJUST NEW MWRS

Because the modifications on this vehicle have changed the height of the MWRS from its original condition, it will be necessary to adjust the SST reflector height to match the height of the MWRS. When following the MWRS Adjustment procedure in the Repair Manual, change the height of the SST reflector to match the center of the MWRS in the grille.

- a. Adjust the height of the SST reflector to the center of the MWRS in the grille.
- b. Follow the Repair Manual procedure to properly calibrate the MWRS.

### CRUISE CONTROL: MILLIMETER WAVE RADAR SENSOR: ADJUSTMENT

(RM1000000018991)

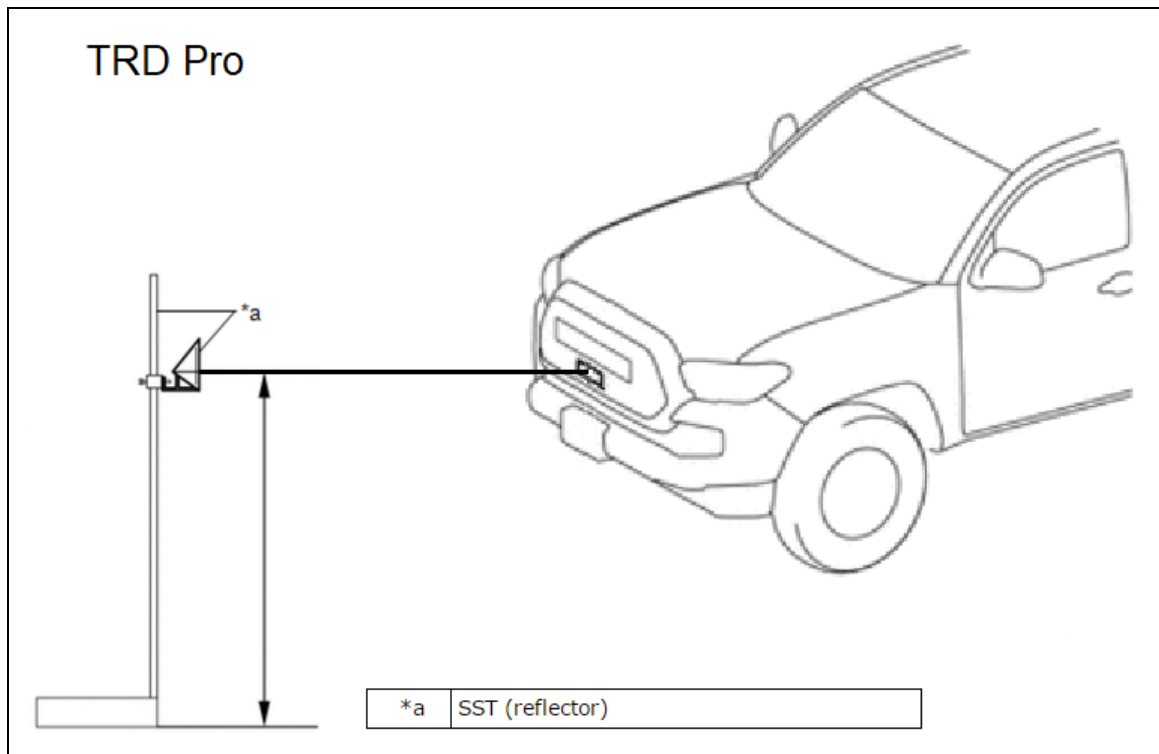

**Proceed to DETERMINE CALIBRATION STATUS on p. 33**

## XII. TUNDRA - REPAIR A

TUNDRA Repair A vehicles will have a radiator grille of this design:

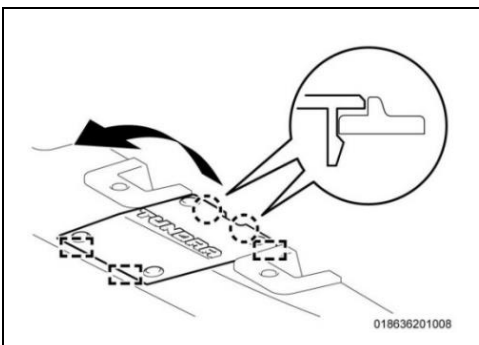
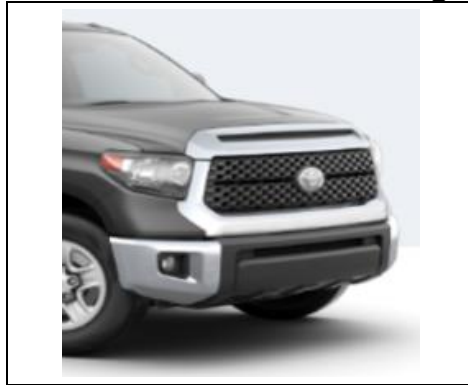

### 1. REMOVE RADIATOR GRILLE

- a. Detach the 2 claws and 3 guides to remove the cover.
- b. Disconnect the electrical connector under the cover.

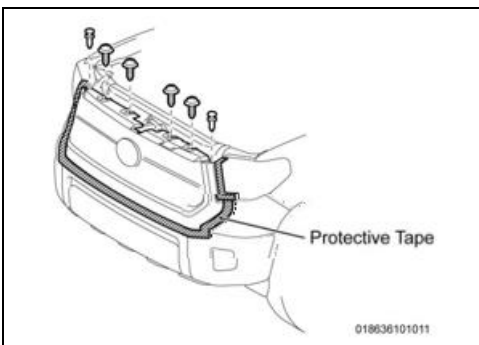

- c. Place protective tape on the front bumper and headlights, at the edge of the grille assembly, to protect the surfaces during removal and installation.
- d. Remove the 4 screws and 2 clips

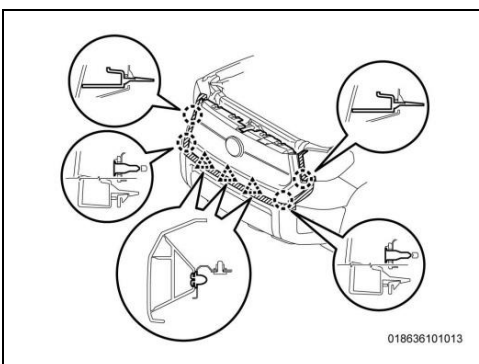

- e. Detach the 4 claws and 3 clips by pulling the grille assembly forward.

## 2. DETERMINE IF A NEW MWRS IS REQUIRED

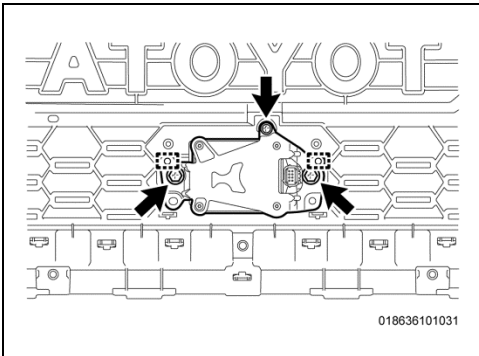
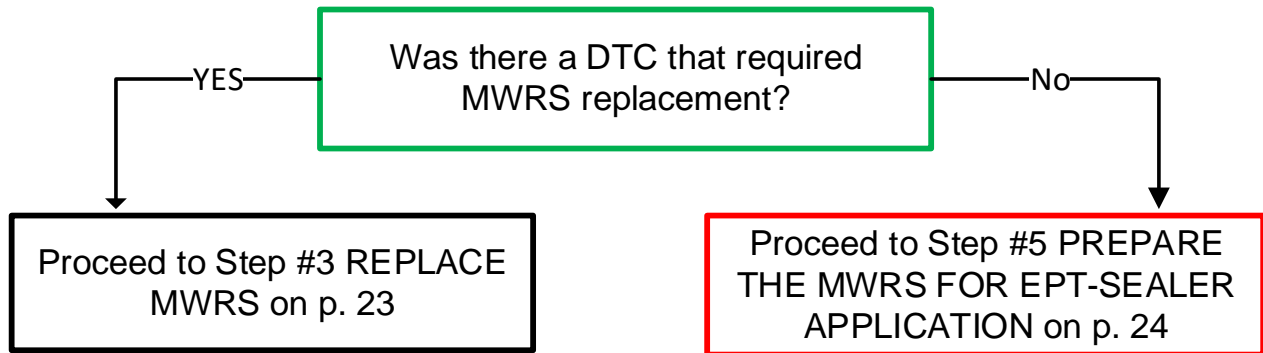

### 3. REPLACE MWRS (only if required)

- Remove the 2 bolts and screw.
- Remove the original MWRS.
- Install the **NEW** MWRS by engaging the 2 guides of the grille into the guide holes of the MWRS.
- Install the 2 bolts and screw.

**Torque: 2.5 N·m (25 kgf·cm, 22 in.lbs)**

## 4. DETERMINE IF EPT-SEALER IS NECESSARY FOR **NEW** SENSOR

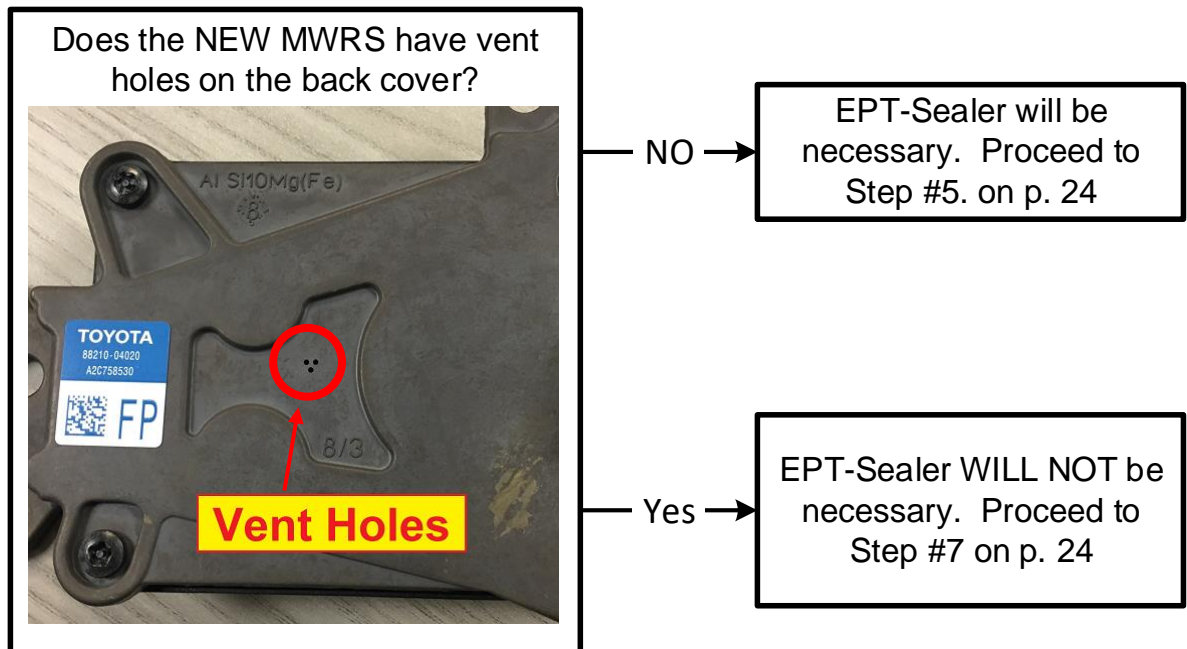

## 5. PREPARE THE MWRS FOR EPT APPLICATION

- a. Place a blanket onto the table or workbench.
- b. Place the radiator grille onto the blanket, front side down.
- c. Using general purpose cleaner and a clean towel, clean the back side of the MMRS sensor and the emblem area on the back side of the grille.

## 6. APPLY EPT-SEALER

**Note:** This application will use P/N **88278-0C010**. (75mm x 150mm x 5mm)

**Video:** [Tundra EPT Sealer Installation Type A](#)

- a. Apply the EPT Sealer to the back face of the MWRS in the position shown below.
- b. Roll the EPT sealer onto the inside lip of the radiator grille to create a waterproof shield over the top of the sensor.
- c. Using finger pressure, thoroughly press the entire surface of the EPT sealer to securely adhere it to all contact surfaces.



Recommended temperature for adhesion is 50° F and above.  
Keep stock at room temperature.

## 7. REINSTALL THE RADIATOR GRILLE

- a. Attach the 4 claws and 3 clips to install the grille.
- b. Install the 4 screws and 2 clips.
- c. Remove the protective tape.
- d. Connect the electrical connector.
- e. Reinstall the cover.



## 8. DETERMINE IF MWRS ADJUSTMENT IS NECESSARY

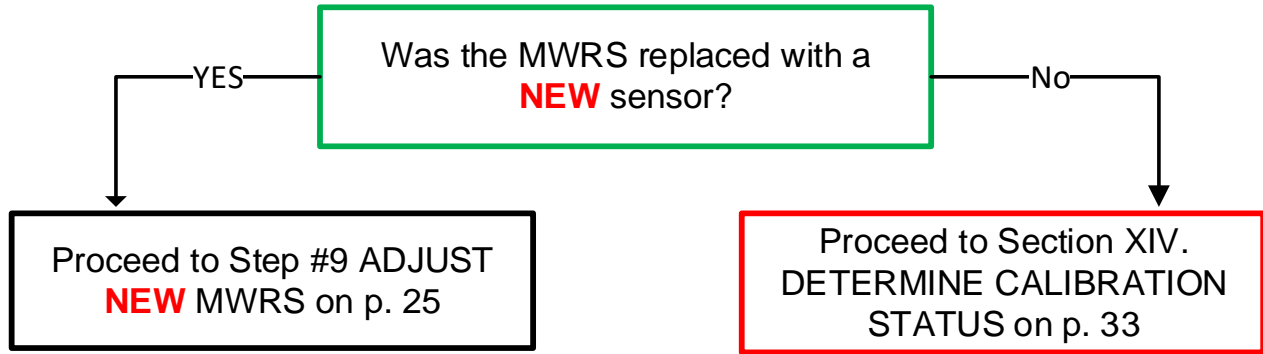

## 9. ADJUST NEW MWRS

Because the modifications on this vehicle have changed the height of the MWRS from its original condition, it will be necessary to adjust the SST reflector height to match the height of the MWRS. When following the MWRS Adjustment procedure in the Repair Manual, change the height of the SST reflector to match the center of the MWRS in the grille.

- Adjust the height of the SST reflector to the center of the MWRS in the grille.
- Follow the Repair Manual procedure to properly calibrate the MWRS.

### [CRUISE CONTROL: MILLIMETER WAVE RADAR SENSOR: ADJUSTMENT](#)

(RM1000000015LKF)

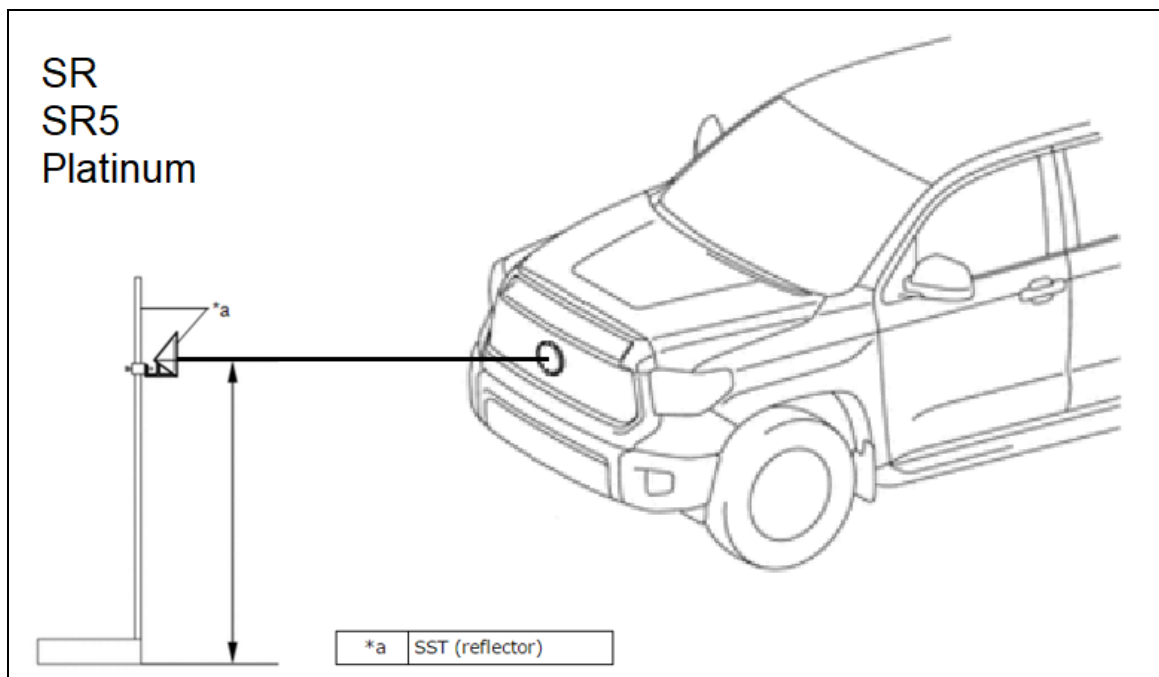

**Proceed to DETERMINE CALIBRATION STATUS on p. 33**

### XIII. TUNDRA - REPAIR B

TUNDRA Repair B vehicles will have radiator grilles of these designs:

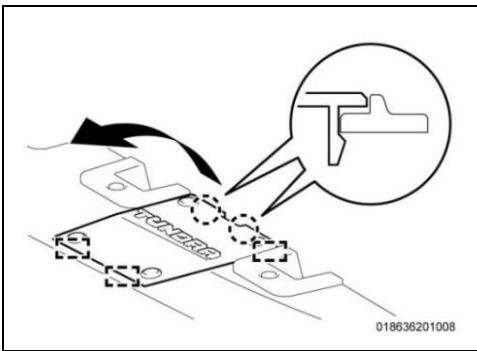

#### 1. REMOVE RADIATOR GRILLE

- a. Detach the 2 claws and 3 guides to remove the side grille.
- b. Disconnect the electrical connector under the cover.

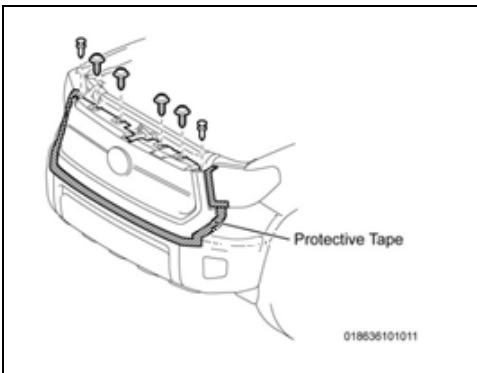

- c. Place protective tape on the front bumper and headlights, at the edge of the grille assembly, to protect the surfaces during removal and installation.
- d. Remove the 4 screws and 2 clips

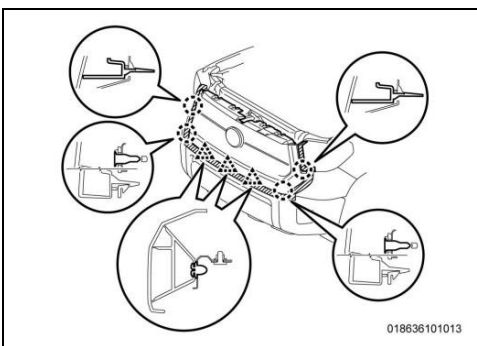

- e. Detach the 4 claws and 3 clips by pulling the grille assembly forward.
- f. Place a blanket onto the table or workbench.
- g. Place the radiator grille onto the blanket, front side down.

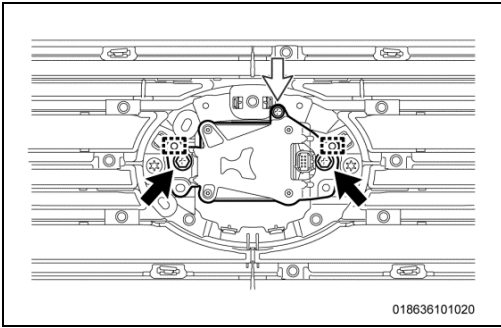

## 2. REMOVE MWRS FROM GRILLE

- Disconnect the electrical connector.
- Remove the 2 bolts and 1 screw.
- Remove the MWRS from the radiator grille.

## 3. DETERMINE IF A NEW MWRS IS REQUIRED

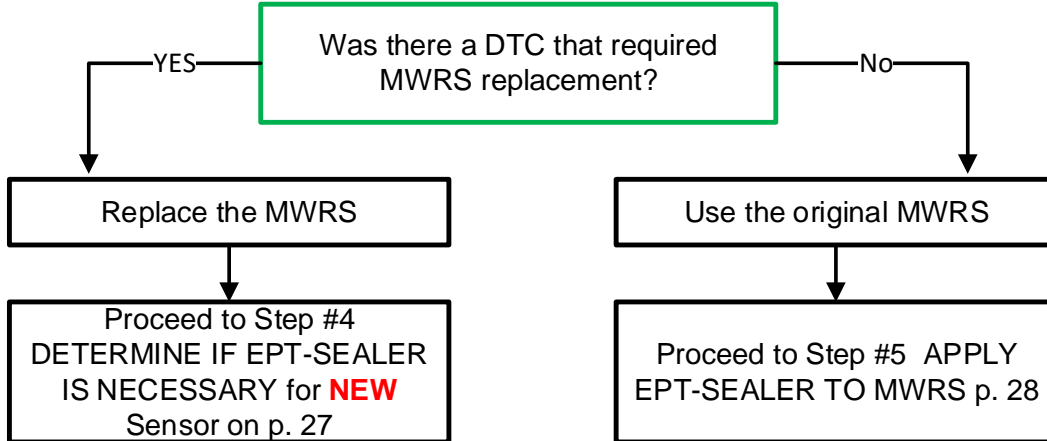

## 4. DETERMINE IF EPT-SEALER IS NECESSARY FOR **NEW** SENSOR

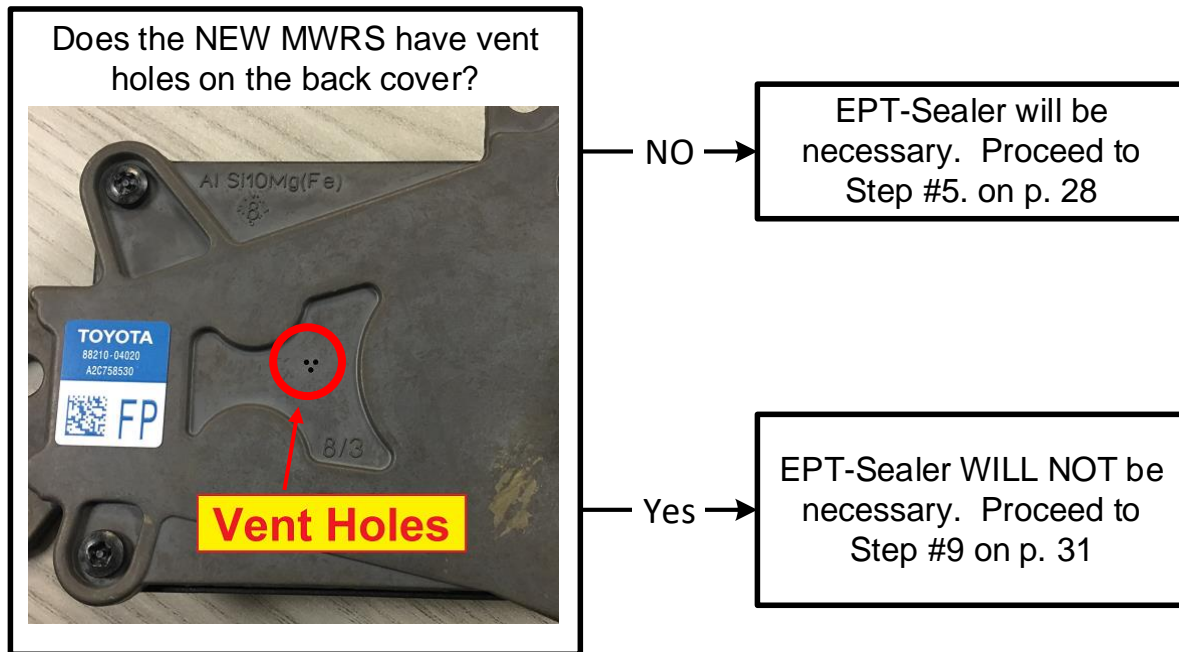

## 5. APPLY EPT-SEALER TO MWRS

Note: This application will use P/N **88278-0C020**. (46mm x 32mm x 5mm)

The EPT-Sealer will be applied in a specific way, using the following points for orientation. Please note the arrangement of corners A, B, C, D.

Video: [EPT Sealer Installation Repair B](#)

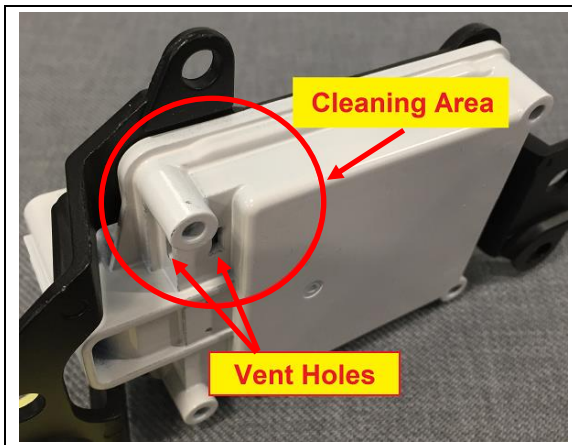
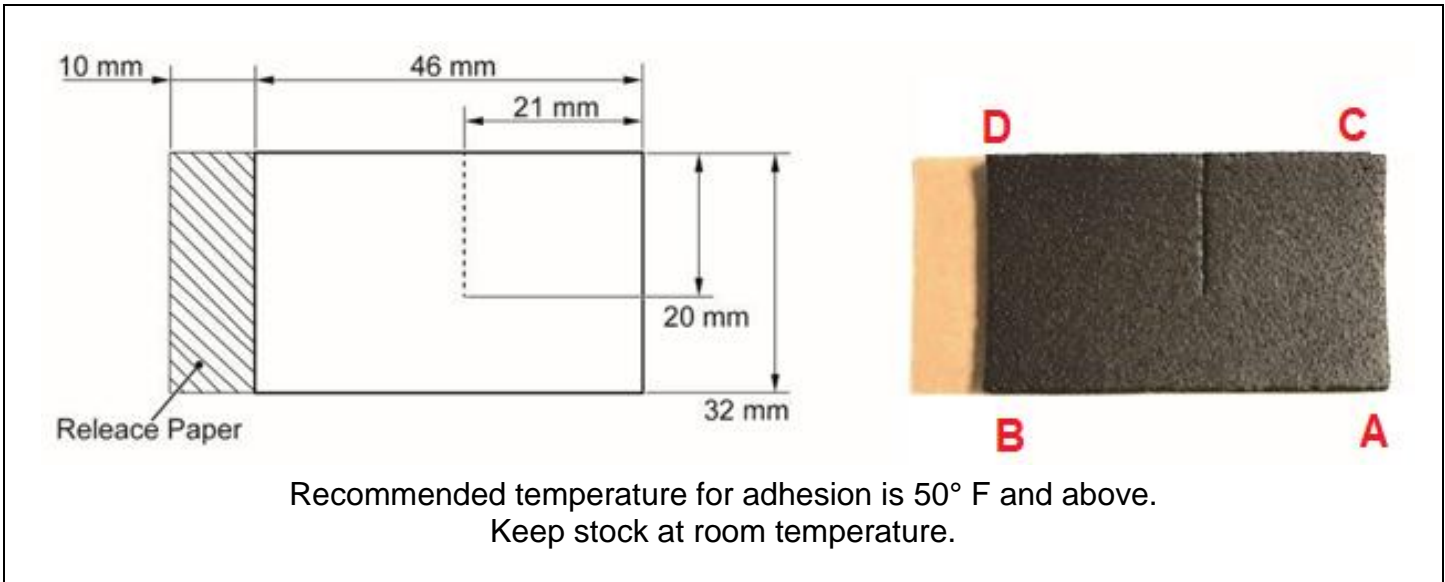

## 6. CLEAN THE APPLICATION AREA

- a. Using general purpose cleaner, remove all traces of dust, dirt, and oils or grease from the application area (indicated within the red circle). Be careful not to get any liquids into the 2 vent holes.

Note: The MWRS housing has been painted white in these photos to provide more contrast in the pictures. The actual MWRS housings will be black.

Left Side

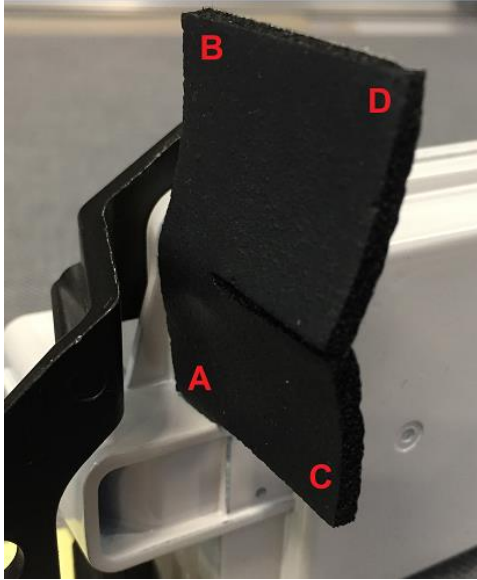

## 7. APPLY THE EPT SEALER

- a. Wear Nitrile Gloves to prevent adhesive contamination.
  - b. Apply the EPT-Sealer to the left side of the MWRS to the following standard:
    - **Left Side View:** Corner "A" of the EPT-Sealer should be placed at the inner corner of the MWRS as indicated.
    - **Top View:** Place the EPT-Sealer on the surface of the side vent hole (it is ok to cover the side vent hole). **DO NOT place the EPT Sealer on top of the ridge**, as indicated with the yellow X's.
- Note:** A diagram of the EPT sealer can be found on page 15.
- c. Press the EPT sealer firmly into place in this area to seat it thoroughly. Use flathead screw driver or trim tool if necessary to reach the corner.

Top View

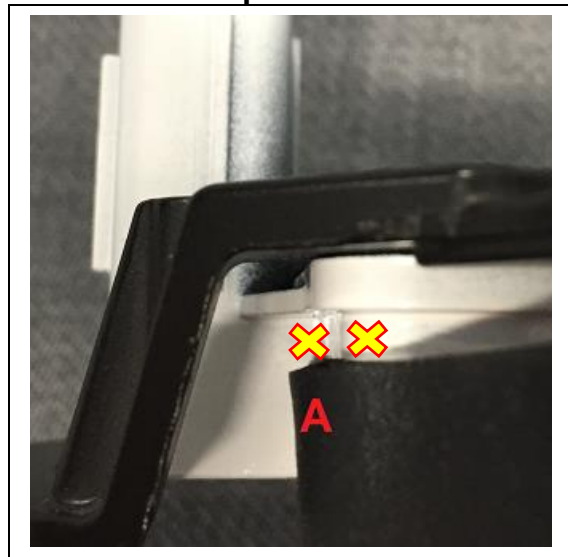

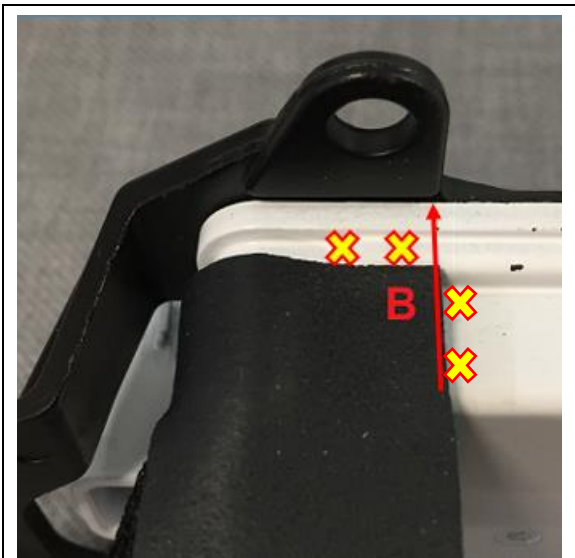

- d. Roll the EPT-Sealer Corner "B" onto the top edge of the MWRS sensor as shown, **aligning its edge with the end of the metal bracket. Be sure to keep the EPT-Sealer off the upper ridge.**
- e. Press the EPT sealer firmly into place in this area to seat it thoroughly.

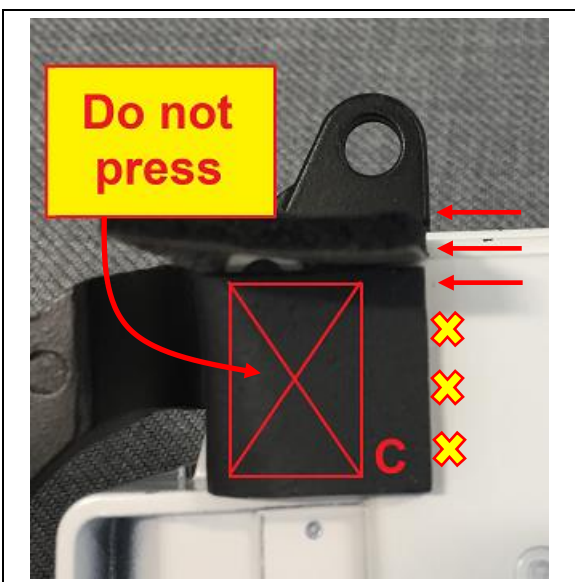

- f. Bend the lower flap (Corner "C") onto the face of the MWRS and align the edge with the edge of the upper flap and metal bracket.
- g. Press the EPT-Sealer into the face of the MWRS to seat it firmly. **DO NOT** press in the area indicated as it's critical there is an air gap for the vent.

	<p><b>ONLY PRESS THE EPT SEALER ONTO THE FACE OF THE MWRS. DO NOT press the EPT sealer into the vent hole. It's critical that the vent hole remains open.</b></p>
--	---

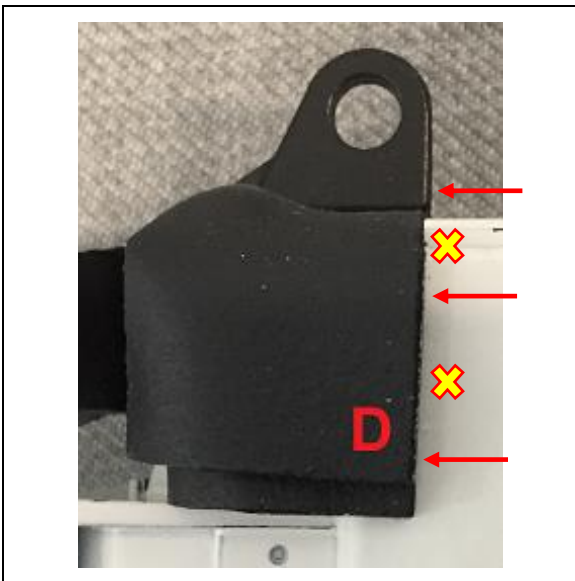

- h. Roll Corner "D" downward from the top, aligning the edge with the edge of the lower section and metal bracket.
- i. Press the EPT sealer into place, being careful to leave an airgap above the rear vent hole.

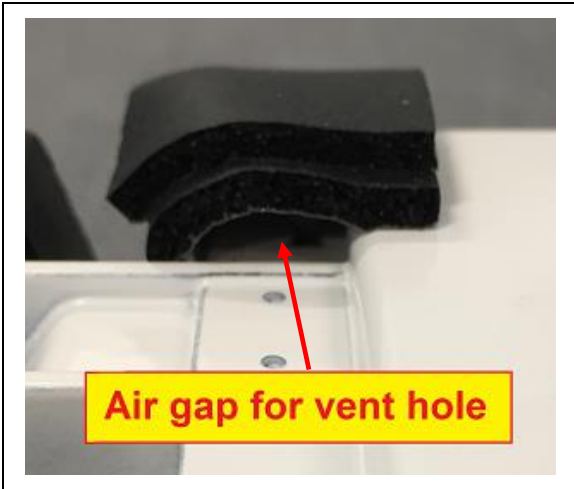

#### 8. INSPECT THE EPT-SEALER APPLICATION

- a. Verify that all the contact points of the EPT sealer are thoroughly applied.
- b. Verify that the bottom is still open to properly allow airflow to the rear vent hole.

**Note:** In case of failure during inspection, start over with a new piece of EPT-Sealer.

#### 9. REINSTALL THE MWRS

- a. Engage the 2 guides of the grille into the guide holes of the MWRS.
- b. Install the 2 bolts and screw.

**Torque:** 2.5 N·m (25 kgf·cm, 22 in.lbs)

#### 10. REINSTALL THE RADIATOR GRILLE

- a. Engage the 4 claws and 3 clips to install the radiator grille assembly.
- b. Install the 4 screws and 2 clips.
- c. Remove the protective tape.
- d. Connect the electrical connector.
- e. Install the Side Grille by engaging the 2 claws and 3 guides.

## 11. ADJUST THE MWRS

Because the modifications on this vehicle have changed the height of the MWRS from its original condition, it will be necessary to adjust the SST reflector height to match the height of the MWRS. When following the MWRS Adjustment procedure in the Repair Manual, change the height of the SST reflector to match the center point height of the MWRS in the grille.

- Adjust the height of the SST reflector to the center point of the MWRS in the grille.
- Follow the Repair Manual procedure to properly calibrate the MWRS.

### CRUISE CONTROL: MILLIMETER WAVE RADAR SENSOR: ADJUSTMENT

(RM1000000015LKF)

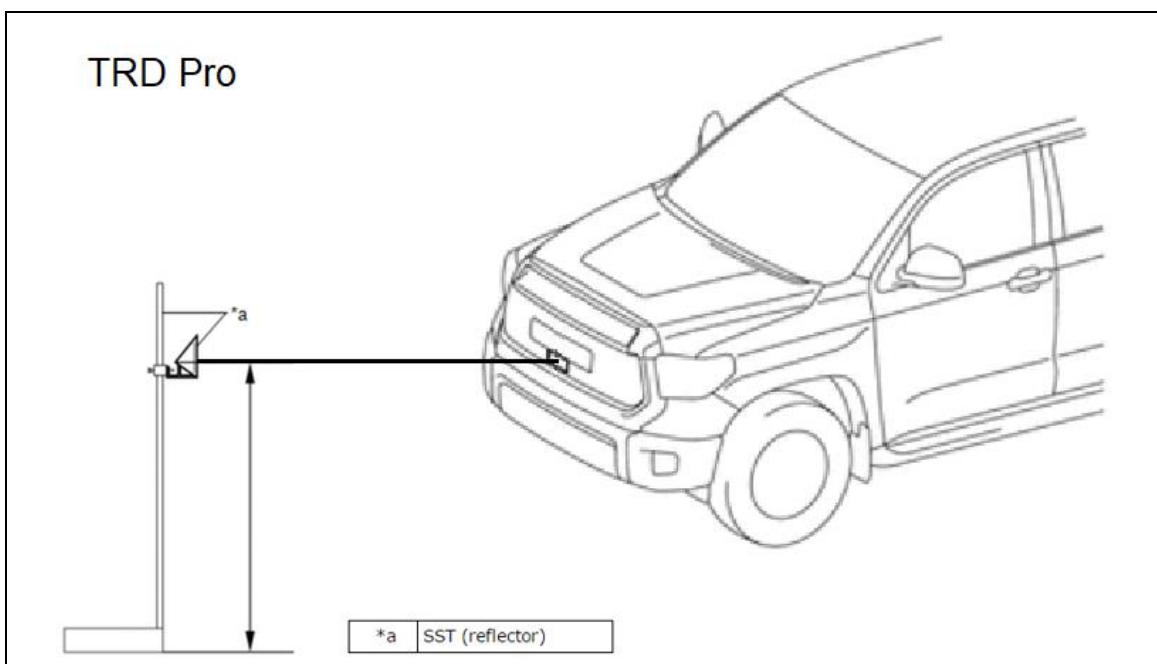
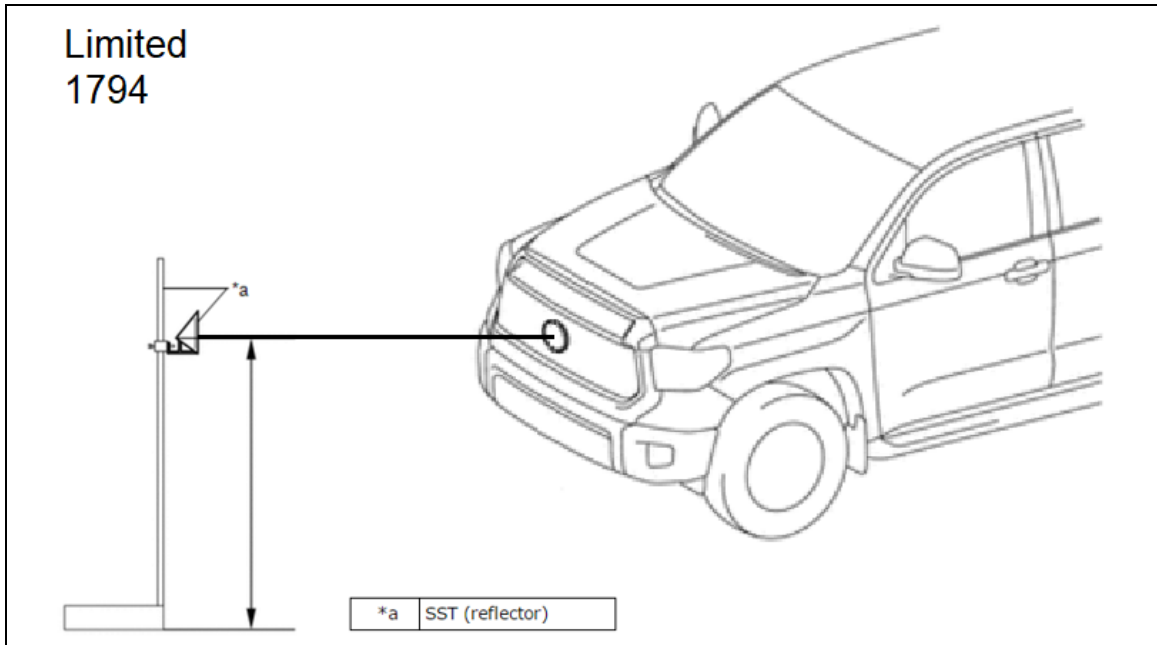



## XIV. DETERMINE CALIBRATION STATUS



### 1. CHECK FOR DTC'S

- Using a Techstream, perform a Health Check.

**Note:** This Service Campaign covers only the application of the EPT-Sealer and Calibration ID update for the Pre-Collision 2 System, as detailed in these instructions. It does not cover the diagnosis or replacement of any other parts on the vehicle.

### 2. CHECK CURRENT CALIBRATION

- Locate the Update column for the **Pre-Collision 2** System in the Stored Data tab.
- Determine the status of an available update; indicated by a **Yes** or **No**.

System Select **Stored Data**

2018 Tundra  
3UR-FE

016018 mile  
Production Date  
- 10/2017

2018\_Tundra\_3U  
File Notes  
Health Check  
Data 1-1/2

Tire Pressure / Threshold Value [psi(gau

Sensor 1: 37.66 / 27.68 Sensor 2:  
Sensor 3: 37.41 / 27.68 Sensor 4:  
Sensor 5: 37.66 / 27.68

Health Check Results

- Health Check does not display live data.
- Changes in vehicle condition will not update
- To update Health Check, click the Refresh bu

Enhanced | Generic |

Campaign Status: **OPEN**  
PERMANENT: **NO**

System	SB	RoB	Calibration	Update
Tilt&Telescopic	-	-	-	
SRS Airbag	-	-	8917F0C035	No
Navigation System	-	-	-	
<b>Pre-Collision 2</b>	-	-	8821F0C01400	<b>Yes</b>
Front Radar Sensor	-	-	8821F0C01400	Yes
Mirror R	-	-	-	
Mirror L	-	-	-	
Immobiliser	-	-	-	
Blind Spot Monitor Master	-	-	8816F0C02101	No
Blind Spot Monitor Slave	-	-	8816F0C02102	No
Central Gateway	-	-	8911F0C01001	No

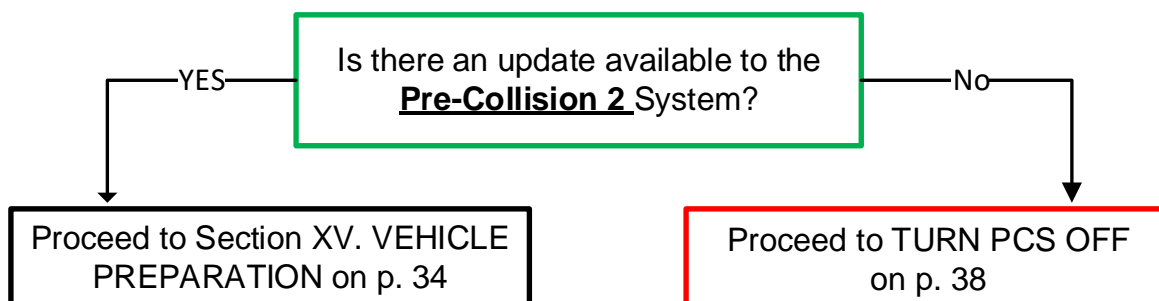

## XV. VEHICLE PREPARATION

### 1. VEHICLE PREPARATION

a. Confirm the following conditions:

- Vehicle in the IG position (engine off).
- Transaxle in Park.
- Parking brake engaged.
- Turn off all electrical accessories (i.e. climate control, audio system, etc.)
- Headlight switch in the DRL OFF position.
- Windshield wiper switch in the OFF position.

### 2. CONNECT THE 12v BATTERY TO A POWER SUPPLY (GR8)

- a. Connect the GR8 or other type of a power supply (not a battery charger) to the 12v battery.  
b. Select the Power Supply Mode from the Charge Menu of the GR8.



**A power supply *MUST* be used during reprogramming. ECU damage will occur if the battery voltage is not properly maintained during this re-flash procedure.**

**Note:** A power supply must be connected directly to the 12v battery terminals and NOT the remote jump posts under the hood (if equipped).

### 3. VERIFY TECHSTREAM SETUP

a. Verify that the Techstream meets the following conditions:

- The latest version of software is loaded.
- The Techstream battery is fully charged. If not, connect the Techstream to a 120v source.
- The DLCIII cable is in good condition.



**The Techstream's battery voltage must be maintained during the update procedure. If necessary, plug the Techstream into a 120v outlet during this procedure.**

**Note:** If the Techstream's communication with the vehicle fails during the update procedure, the ECU will be damaged.

## XVI. UPDATE CALIBRATION

### 1. UPDATE THE CALIBRATION ID

- Identify the vehicles Current CID for the **Pre-Collision 2** System on the Stored Data tab.

System Select **Stored Data**

2018 Tundra  
3UR-FE

016018 mile  
Production Date  
- 10/2017

2018\_Tundra\_3U  
File Notes  
Health Check  
Data 1-1/2

Tire Pressure / Threshold Value [psi(gau

Sensor 1: 37.66 / 27.68 Sensor 2:  
Sensor 3: 37.41 / 27.68 Sensor 4:  
Sensor 5: 37.66 / 27.68

Health Check Results

- Health Check does not display live data.
- Changes in vehicle condition will not update
- To update Health Check, click the Refresh bu

Campaign Status: **OPEN**  
PERMANENT: **NO**

Enhanced | Generic

System	Current CID	Calibration	Update
Tilt&Telescopic	-	-	-
SRS Airbag	-	8917F0C035	No
Navigation System	-	-	-
<b>Pre-Collision 2</b>	-	8821F0C01400	Yes
Front Radar Sensor	-	8821F0C01400	Yes
Mirror R	-	-	-

- Locate the vehicles Current CID in the chart on the following page.
- Select the corresponding NEW CID link to load the update.
- Follow the on-screen instructions to complete the Calibration Update procedure.

**The CID Update Procedure is detailed in [T-SB-0134-16](#).** Please reference this Bulletin for more detailed procedures and information.



**Be extremely careful to select the correct NEW CID that corresponds to the Current CID.**

Vehicle Specification		Millimeter Wave Radar Sensor Calibrations	
Model	Type	Current CID	New CID
TUNDRA	Non-TRD Pro	8821F0C0 <u>1100</u>	<a href="#"><u>8821F0C01500</u></a>
		8821F0C0 <u>1200</u>	
		8821F0C0 <u>1300</u>	
		8821F0C0 <u>1400</u>	
	TRD Pro	8821F0C0 <u>3100</u>	<a href="#"><u>8821F0C03500</u></a>
		8821F0C0 <u>3200</u>	
		8821F0C0 <u>3300</u>	
		8821F0C0 <u>3400</u>	
TACOMA	Non-TRD Pro	8821F040 <u>1100</u>	<a href="#"><u>8821F0405100</u></a>
		8821F040 <u>1200</u>	
		8821F040 <u>5000</u>	
	TRD Pro	8821F040 <u>2100</u>	<a href="#"><u>8821F0406100</u></a>
		8821F040 <u>2200</u>	
		8821F040 <u>6000</u>	



**2. PERFORM VERIFICATION HEALTH CHECK**

- a. Clear DTC's that may have set during the re-flash procedure.
- b. **Re-run the Health Check to confirm that no DTC's reappear.**



**THIS VERIFICATION HEALTH CHECK IS NECESSARY to update the results and CID's to the National database.**

### 3. CONFIRM CID UPDATE

a. On the Stored Data tab, confirm the following for the **Pre-Collision 2** System:

- The Update column lists “No”

System Select **Stored Data**

2018 Tundra  
3UR-FE

016018 mile  
Production Date  
- 10/2017

2018\_Tundra\_3L  
File Notes  
Health Check  
Data 1-1/2

Tire Pressure / Threshold Value [psi(gau

Sensor 1: 37.66 / 27.68 Sensor 2:  
Sensor 3: 37.41 / 27.68 Sensor 4:  
Sensor 5: 37.66 / 27.68

Campaign Status: **OPEN**  
PERMANENT: **NO**

Health Check Results

- Health Check does not display live data.
- Changes in vehicle condition will not update
- To update Health Check, click the Refresh button

Enhanced | Generic

System	SB	RoB	Calibration	Update
Tilt&Telescopic	-	-	-	
SRS Airbag	-	-	8917F0C035	No
Navigation System	-	-	-	
<b>Pre-Collision 2</b>	-	-	8821F0C01500	<b>No</b>
Front Radar Sensor	-	-	8821F0C01500	No
Mirror R	-	-	-	
Mirror L	-	-	-	
Immobiliser	-	-	-	
Blind Spot Monitor Master	-	-	8816F0C02101	No
Blind Spot Monitor Slave	-	-	8816F0C02102	No
Central Gateway	-	-	8911F0C01001	No

Sort  
Expand>>  
TIS Search

**MUST say "No"**

## XVII. COMPLETE INSTALLATIONS

### 1. UPDATE CUSTOMIZABLE SETTINGS



The Pre-Collision System (PCS) defaults its operating mode to ON after each ignition cycle, even if the system had been turned off (using the meter control switch) during the previous ignition cycle. Because of the ride height modifications on this vehicle, the PCS system may not operate as designed. Therefore, it will be necessary to change this function so that it can remain OFF each time the vehicle is started. Changing the PCS Operation State Retention Setting will default the PCS system to its last setting during each key cycle. Therefore, the system can remain OFF during each ignition cycle.

- a. Follow the instructions as detailed in T-SB-0059-18 to change the PCS Operation State Retention Setting:



[TSB: Pre-Collision System \(PCS\) Customizable Features](#)  
(T-SB-0059-18)

## 2. TURN PCS OFF

Once the Customizable Settings have been updated, it will now be necessary to turn the PCS system to OFF. Follow these steps to turn the PCS OFF:

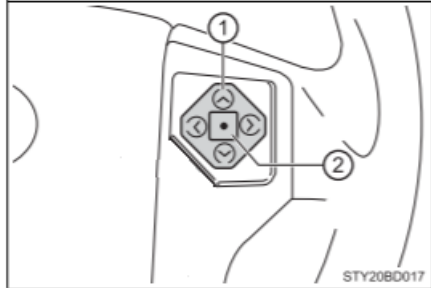
- a. Press the “<” or “>” (#1 below) of the meter control switch (right side of steering wheel) until the  is displayed. Press  (#2 below).



- b. Press “^” of “v” of the meter control to select “PCS” and press .
- c. Press “^” of “v” of the meter control to select “OFF” and press .

Note: With the PCS set to OFF, the PCS warning light will illuminate, and a message will be displayed on the multi-information display.

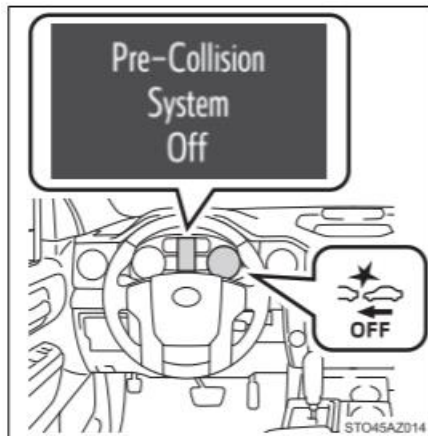

Tundra



Tacoma

## 3. REMOVE POWER SUPPLY

- a. Remove the power supply from the battery.

#### 4. OWNERS MANUAL INSERT

a. Print the Owner's Manual Insert:

##### [SSC K0B Millimeter Wave Radar Sensor Owner's Manual Insert](#)

b. Check the appropriate boxes on the bottom to indicate the modifications present on the vehicle.

SPECIAL SERVICE CAMPAIGN K0B – Owner's Manual Insert					
<p>During the completion of Special Service Campaign K0B, this vehicle was found to be equipped with the non-Toyota-approved modifications noted below.</p> <p>Because this vehicle had non-Toyota-approved modifications, PCS and Dynamic Radar Cruise Control (DRCC) <u>may not operate as designed even after the free remedy is was performed.</u> For example:</p> <ul style="list-style-type: none"><li>• PCS may activate even if a collision is not likely.</li><li>• PCS may not recognize a vehicle or a pedestrian when a preceding vehicle or pedestrian is ahead.</li></ul> <p>For more information on the effects of non-Toyota-approved modifications on PCS go to <a href="http://www.toyota.com/content/ebrochure/CFA_TSS_Precautions.pdf">www.toyota.com/content/ebrochure/CFA_TSS_Precautions.pdf</a>.</p> <p>When the dealer performed the campaign remedy, PCS was set to "OFF" and PCS was configured to retain the last setting following a key cycle. <i>Toyota recommends the PCS and DRCC system NOT be used when non-Toyota-approved modifications are installed on the vehicle.</i> Constant speed control mode should be used instead of DRCC if cruise control is used. If the vehicle is returned to factory condition, the PCS and DRCC systems can be used.</p>	<p><i>NOTE: While PCS is deactivated, the PCS warning light will be displayed in the instrument cluster and a message will be displayed on the multi information display. If this light and message are not present, then PCS has been re-activated.</i></p> 				
<p>For more information about the PCS system and how to use constant speed control mode refer to section 4-5 of this owner's manual.</p> <p>The non-Toyota-approved vehicle modification(s) present of the vehicle at the time of K0B repair is(are):</p> <table><tbody><tr><td><input type="checkbox"/> Lift kit changing ride height</td><td><input type="checkbox"/> Oversized Wheels/Tires</td></tr><tr><td><input type="checkbox"/> Grill from different model/trim package installed</td><td><input type="checkbox"/> Other _____</td></tr></tbody></table> <p>Date: _____</p>		<input type="checkbox"/> Lift kit changing ride height	<input type="checkbox"/> Oversized Wheels/Tires	<input type="checkbox"/> Grill from different model/trim package installed	<input type="checkbox"/> Other _____
<input type="checkbox"/> Lift kit changing ride height	<input type="checkbox"/> Oversized Wheels/Tires				
<input type="checkbox"/> Grill from different model/trim package installed	<input type="checkbox"/> Other _____				

c. Place the Insert into Section 4-5 of the Owner's Manual.

## 5. APPLY K0B MODIFIED VEHICLE LABEL

- Apply the yellow K0B Modified Vehicle Label to the left side of the steering column as shown in the photo below.

**Note: Each dealership has received an initial shipment of these labels, sent to the attention of the Service Manager. Additional labels are available for order through the Material Distribution Center.**

### Tacoma Tundra

Use Constant Speed Control. Dynamic Radar Cruise Control should NOT be used due to a non-Toyota-approved modification to this vehicle that has affected ride height. Please refer to the insert in your Owner's Manual or contact  
(K0B Modified Vehicle Label)

Apply the K0B Modified Vehicle Label to the left side of the steering column



## XVIII. CUSTOMER HEALTH CHECK REPORT

### 1. PRINT CUSTOMER HEALTH CHECK REPORT

- From the Stored Data tab, select the Customer Health Check Report button (TIS will launch when button is pressed).

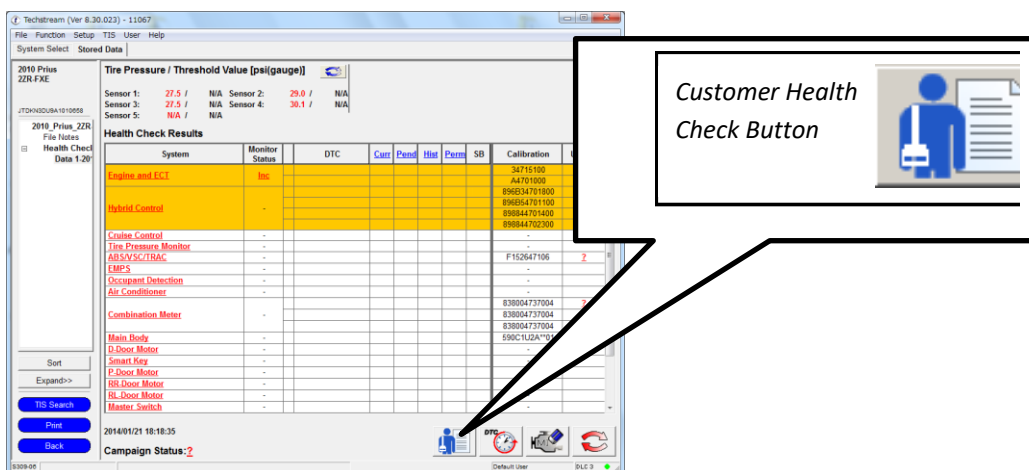

The screenshot shows the Techstream software interface with the 'Health Check Results' screen. The interface includes a menu on the left with options like 'File', 'Function', 'Setup', 'TIS', 'User', and 'Help'. The main area displays 'Tire Pressure / Threshold Value [psi(gauge)]' and 'Health Check Results' with a table of system statuses. A callout box points to the 'Customer Health Check Button' icon in the bottom right corner of the interface.

System	Monitor Status	DTC	Clear	Pass	Fail	Warn	SB	Calibration
Engine and ECT	Inc							34715100 A4701000
Hybrid Control	-							096034701800 096047011000 096044701400 096044702300
Cruise Control	-							
Tire Pressure Monitor	-							
ABS/SC/TRAC	-							F152647106
EBPS	-							
Occupant Detection	-							
Air Conditioner	-							
Combination Meter	-							038004737004 038004737004 038004737004 038004737004
Main Body	-							
D-Door Motor	-							
Smart Key	-							
P-Door Motor	-							
RS-Door Motor	-							
RL-Door Motor	-							
Master Switch	-							

- Log in to TIS.
- Input Vehicle Mileage and Repair Order number.
- Check the "Performed" campaign button for campaign K0B.
- Select the Report button.



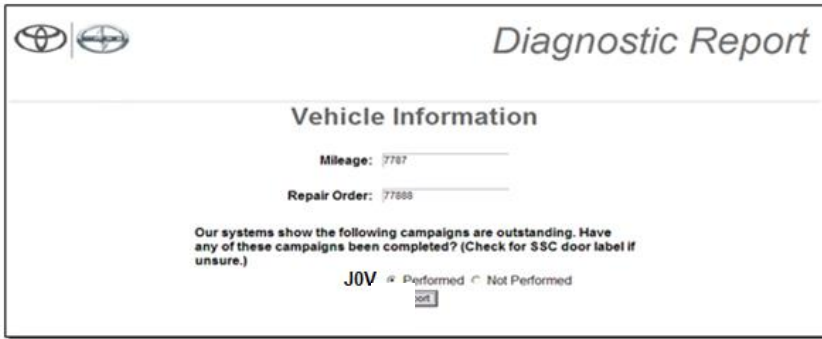

f. Confirm Customer Health Check Report information is correct.

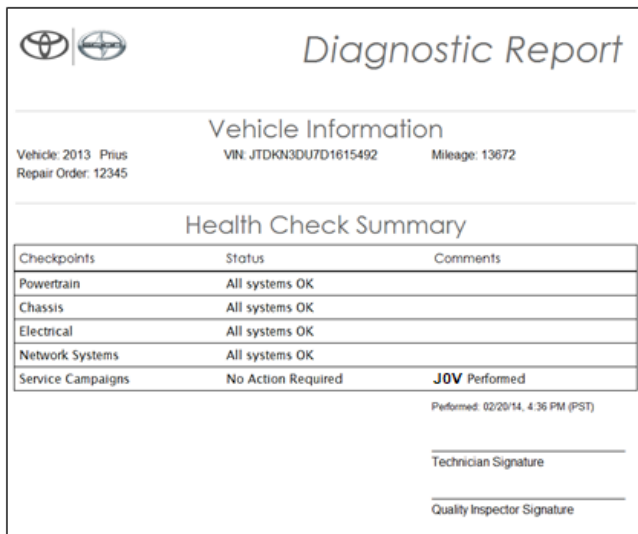

- g. Print Customer Health Check Report from TIS.
- h. Sign and provide to the customer.

**2. ATTACH THE AUTHORIZED VEHICLE MODIFICATION LABEL**

- a. Fill out the label.
- b. Affix the label to the under-side of the hood.

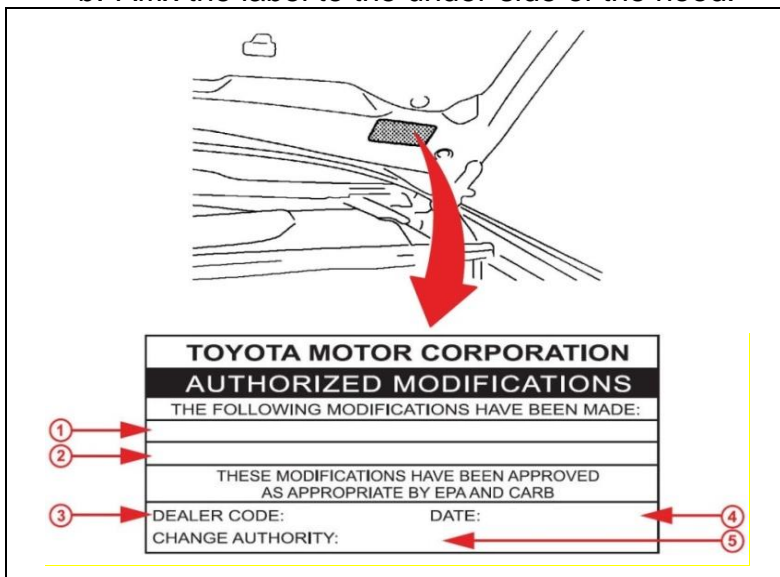

1	<b>Pre Collision</b>
2	(Calibration ID's)
3	(Dealer Code)
4	(Date Completed)
5	<b>Safety Recall K0B</b>

Calibration ID's listed for the Pre Collision 2 System after completing the final Health Check. The CID's will vary for car to car.

## ◀ VERIFY REPAIR QUALITY ▶

- Confirm that the EPT-Sealer is properly applied.
- Confirm that the EPT-Sealer has good adhesion to the MWRS.
- Confirm that the radiator grille is reinstalled correctly.
- Confirm that the system has been properly calibrated, if necessary.
- Confirm that the PCS System is turned OFF.

If you have any questions regarding this update, please contact your regional representative.

### XIX. APPENDIX

#### A. PARTS DISPOSAL

As required by Federal Regulations, please make sure all recalled parts (original parts) removed from the vehicle are disposed of in a manner in which they will not be reused, ***unless requested for parts recovery return.***

#### B. CAMPAIGN DESIGNATION DECORDER

