

IMPORTANT UPDATE

TECHNICAL INSTRUCTIONS FOR SPECIAL SERVICE CAMPAIGN K0B MILLIMETER WAVE RADAR SENSOR

**CERTAIN:
2018 – 2019 TACOMA
2018 – 2019 TUNDRA**

Update 4/2/2019: Instructions provided for Tacoma Bar Type grill EPT Sealer application. Correction made to the Tundra TRD Pro grill photo.

Update 5/2/2019: Instructions updated to confirm proper grill type for vehicle Grade and to identify modified vehicles

The repair quality of covered vehicles is extremely important to Toyota. All dealership technicians performing this recall are required to successfully complete the most current version of the E-Learning course "Safety Recall and Service Campaign Essentials". To ensure that all vehicles have the repair performed correctly; technicians performing this recall repair are required to currently hold at least one of the following certification levels:

- Certified Technician (any specialty)
- Expert Technician (any specialty)
- Master Technician
- Master Diagnostic Technician

It is the dealership's responsibility to select technicians with the above certification level or greater to perform this recall repair. Carefully review your resources, the technician skill level, and ability before assigning technicians to this repair. It is important to consider technician days off and vacation schedules to ensure there are properly trained technicians available to perform this repair at all times.

I. OPERATION FLOW CHART

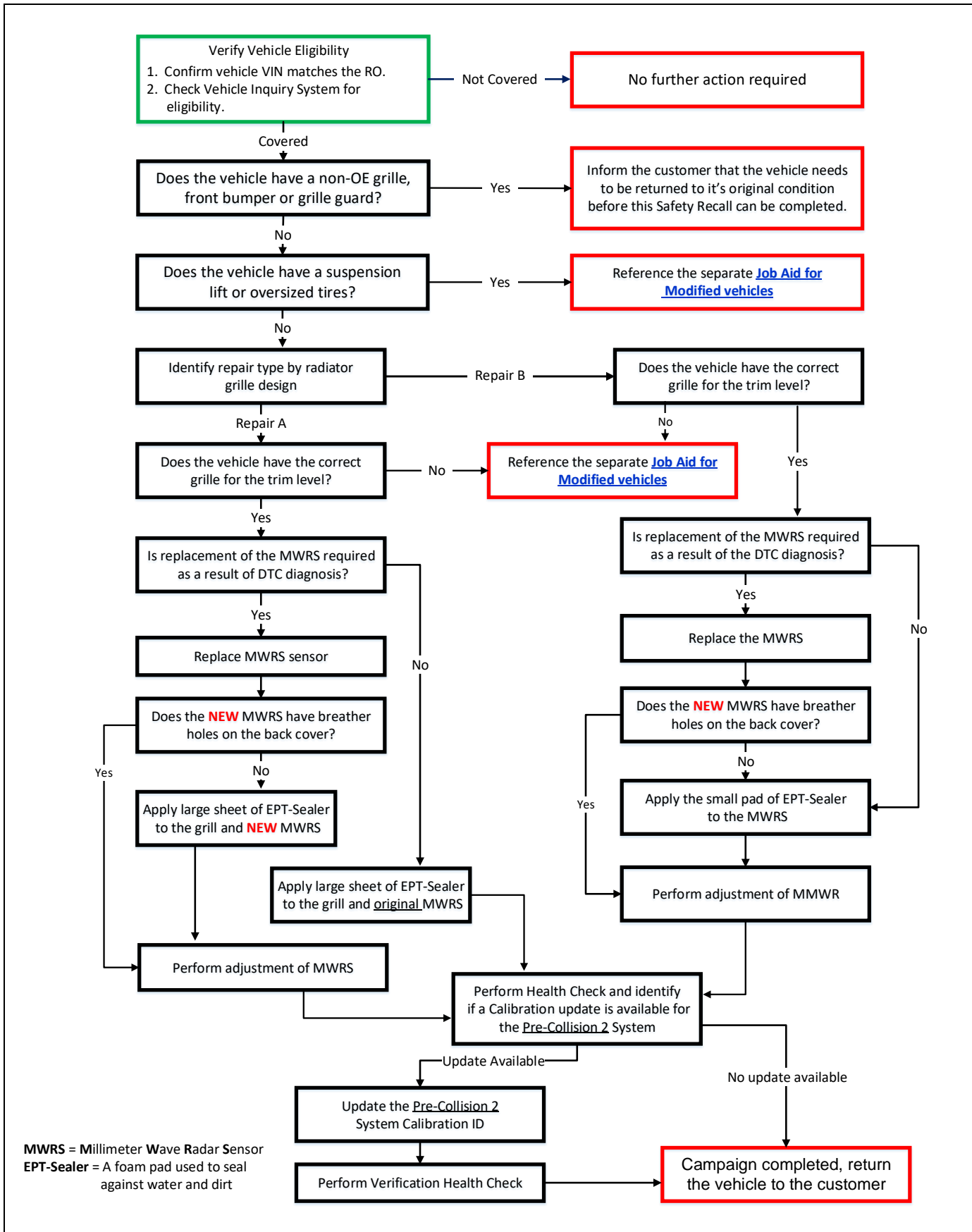

II. IDENTIFICATION OF AFFECTED VEHICLES

1. CHECK VEHICLE FOR CAMPAIGN ELIGIBILITY

- Compare the vehicles VIN to the VIN listed on the Repair Order to ensure they match.
- Check the TIS Vehicle Inquiry System to confirm the VIN is involved in this Campaign, and that it has not already been completed.

Note: TMNA warranty will not reimburse dealers for repairs completed on vehicles that are not affected or were previously completed, even by another dealer.

III. PREPARATION

A. PARTS

Repair A:

Part Number	Part Description	Quantity
88278-0C010	Cushion, Skid control Computer (EPT Sealer Repair A: 75 mm x 150 mm, t = 5 mm)	1

Repair B:

Part Number	Part Description	Quantity
88278-0C020	Cushion, Skid control Computer (EPT Sealer Repair B: 46 mm x 32 mm, t = 3 mm)	1

Part Detail:

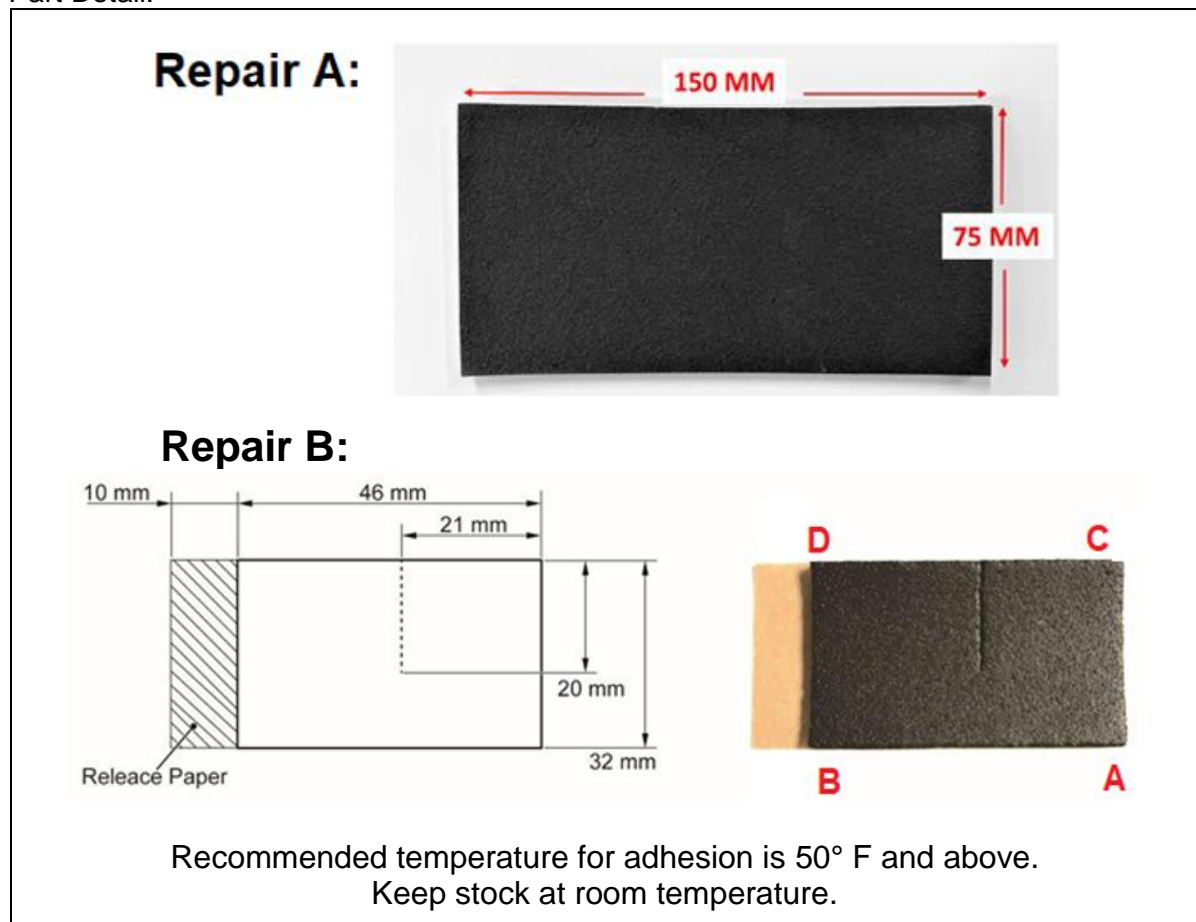

B. TOOLS & EQUIPMENT

- Techstream
- GR8 Battery Station
- Standard Hand Tools
- Nitrile Gloves
- Torque Wrench

C. MATERIALS

- General Purpose Cleaner

IV. BACKGROUND

The involved vehicles are equipped with a Pre-Collision System (PCS) that may automatically apply the brakes if the system detects a potential collision. Due to the mounting of one of the system's sensors, it is possible for water to enter the sensor. This can lead to PCS deactivation or inadvertent brake activation resulting in limited deceleration for a short duration of time.

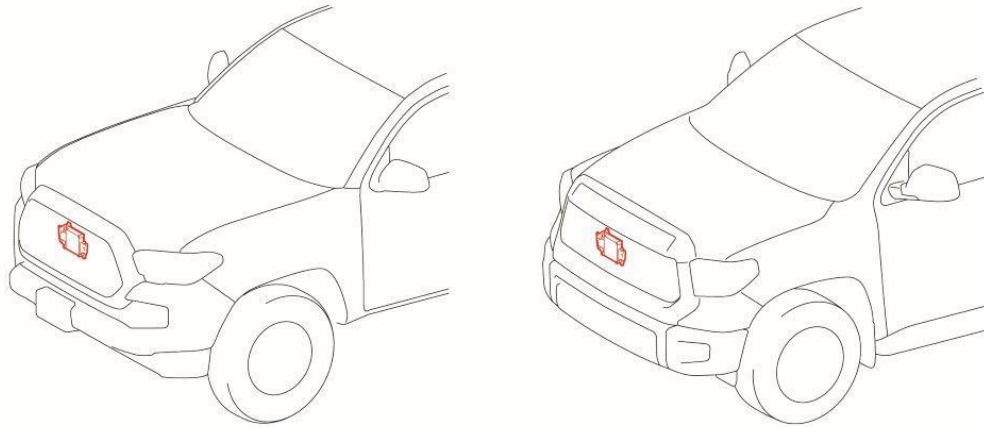

V. INSPECT FOR VEHICLE MODIFICATIONS

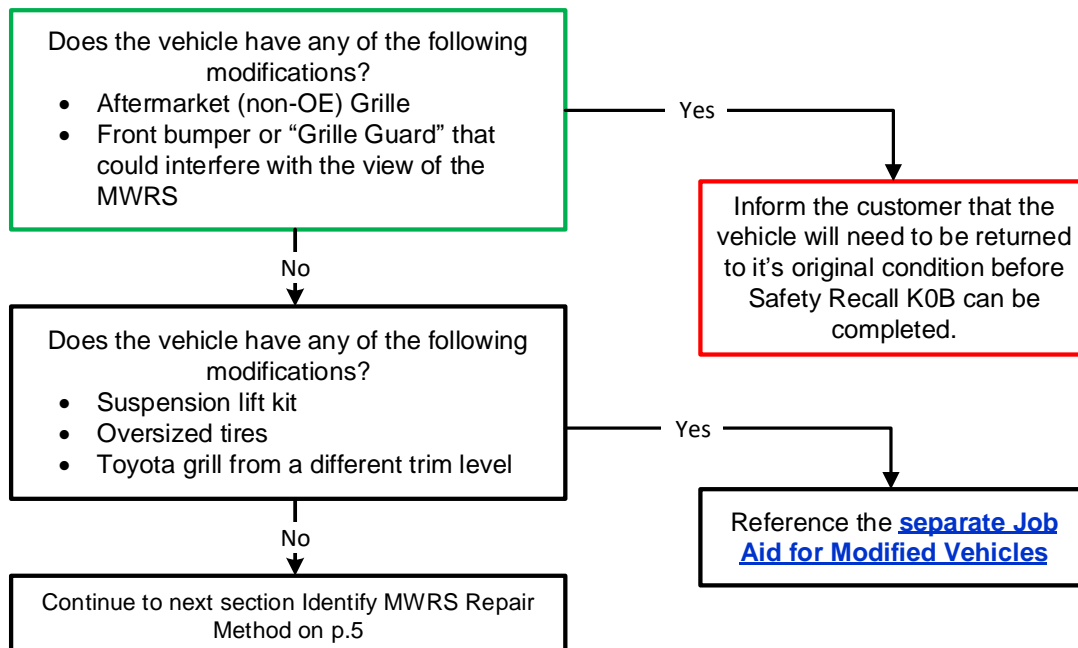

VI. IDENTIFY MWRS REPAIR METHOD (A or B)

1. DETERMINE THE REPAIR METHOD FOR THIS VEHICLE

a. Use the following chart, reference the trim level of each vehicle to determine which repair method to use.

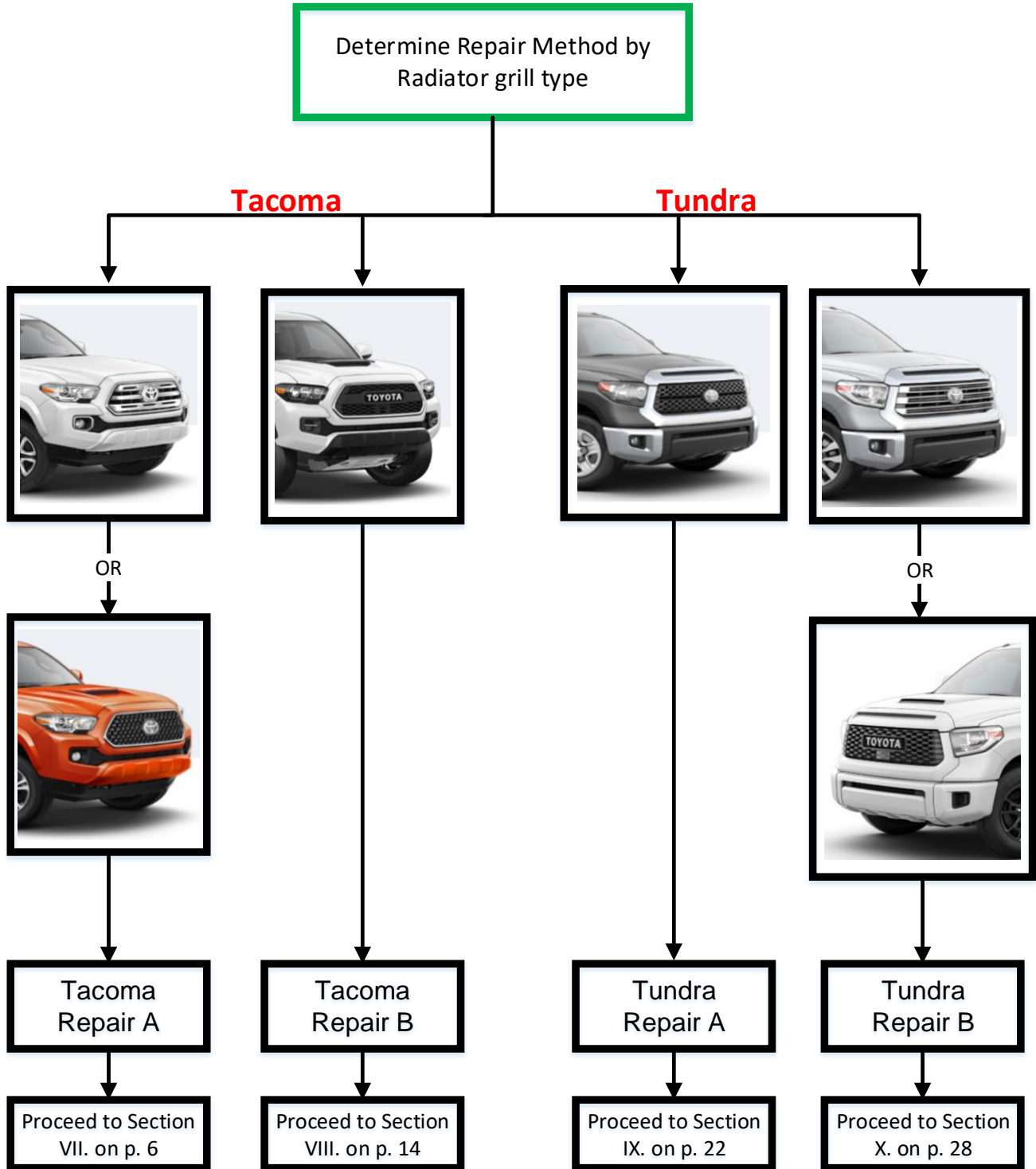

VII. TACOMA - REPAIR A

TACOMA - Repair A vehicles will have radiator grills of these designs:



1. DETERMINE IF THE GRILL IS CORRECT FOR VEHICLE GRADE

- Using the Vehicle Inquiry tab on TIS, input the vehicles VIN and determine the **GRADE** of the vehicle trim.

Library Diagnostics Tech Assistance **Vehicle Inquiry**

Vehicle Identification Number Search

Enter a 17 Digit VIN below to search for applicable information:

VIN: Possible Repeat Repair

Vehicle Information

Division: TOYOTA	Model: Tacoma	Grade: SR5
Drive Type: 2X4	Body Type: D CAB	Engine Family: V6 - 2GR
Date of First Use: 07/12/2018	Production Date:	Plant Code: Q - BAJA CALIFORNIA - TMMBC

VIN: Dest: USA [Electronic Parts Catalog](#) [Flat Rate Manual](#) [Standard Equipment \[+\]](#)

(cont.)

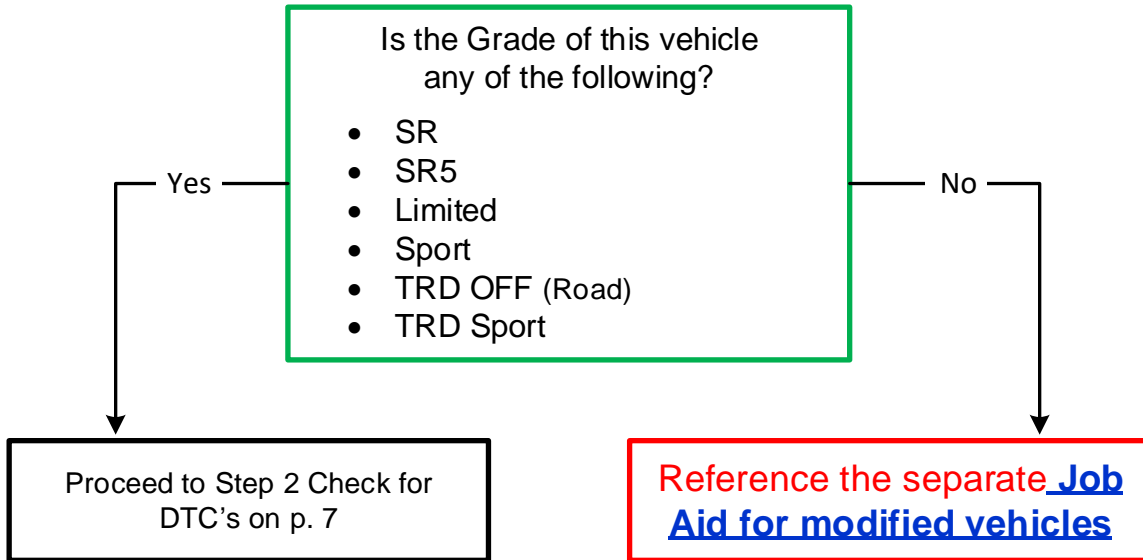

2. CHECK FOR DTC'S

- c. Using a Techstream, perform a Health Check.
- d. Are there any DTC's relating the Pre-Collision system (i.e. C1A10, U0235, U1104) as reported by any system?

Note: *This Service Campaign covers the application of the EPT-Sealer and Calibration ID update for the Pre-Collision 2 System, as detailed in these instructions. It will also cover the replacement cost of the Millimeter Wave Radar Sensor (MWRs), when necessary. It does not cover the diagnosis or replacement of any other parts on the vehicle.*

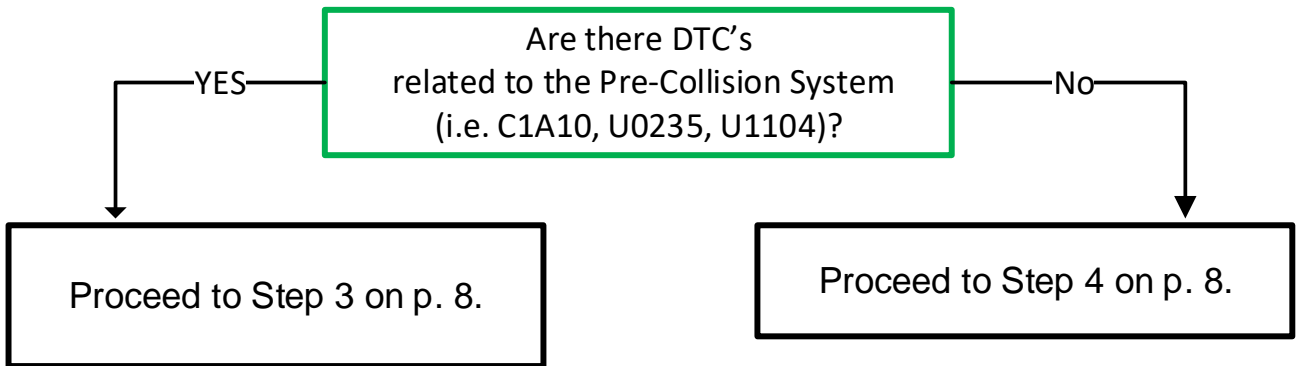

3. DETERMINE THE CAUSE OF PRE-COLLISION SYSTEM DTC'S (if present)

- a. Use the appropriate Repair Manual procedure to determine the cause of the Pre-Collision System DTC's, if present.

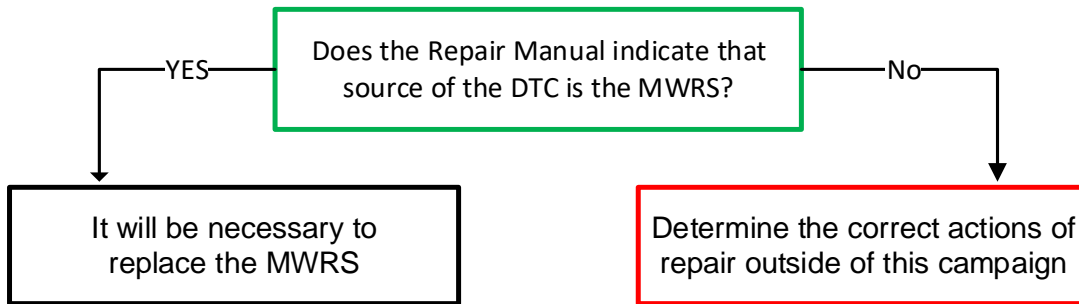

Note: Because there are multiple reasons that could cause Pre-Collision system failures, it's critical to diagnose the system to determine the source of the trouble. This campaign will only cover the replacement of the Millimeter Wave Radar Sensor, which is located behind the Toyota emblem of the radiator grill. If the diagnostic process identifies that the DTC's are caused by something other than the Millimeter Wave Radar Sensor, this campaign will not cover the cost associated with the repair.

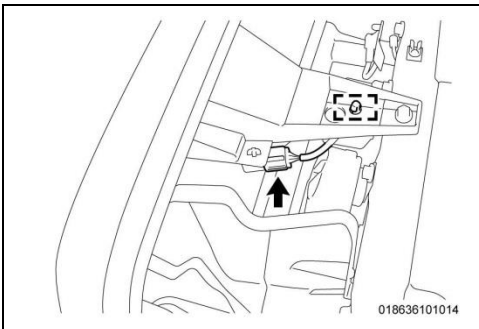

4. REMOVE RADIATOR GRILL

- a. Disconnect the electrical connector.
- b. Disengage the clamp.

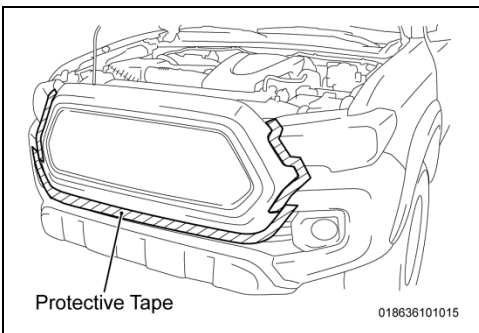

- c. Apply protective tape around the radiator grille.

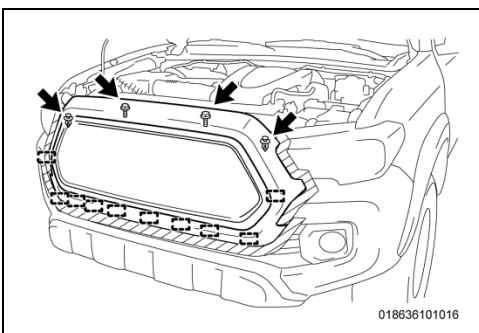

- d. Remove the 2 screws.
- e. Remove the 2 clips.
- f. Disengage the 10 guides to remove the grille.

5. DETERMINE IF A NEW MWRS IS REQUIRED

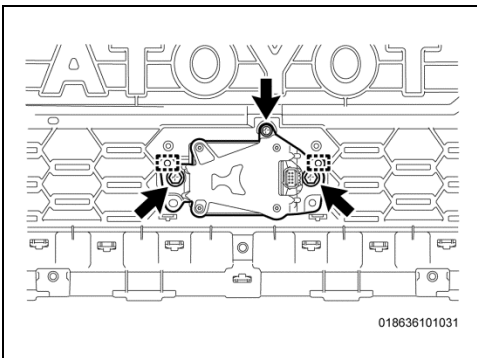
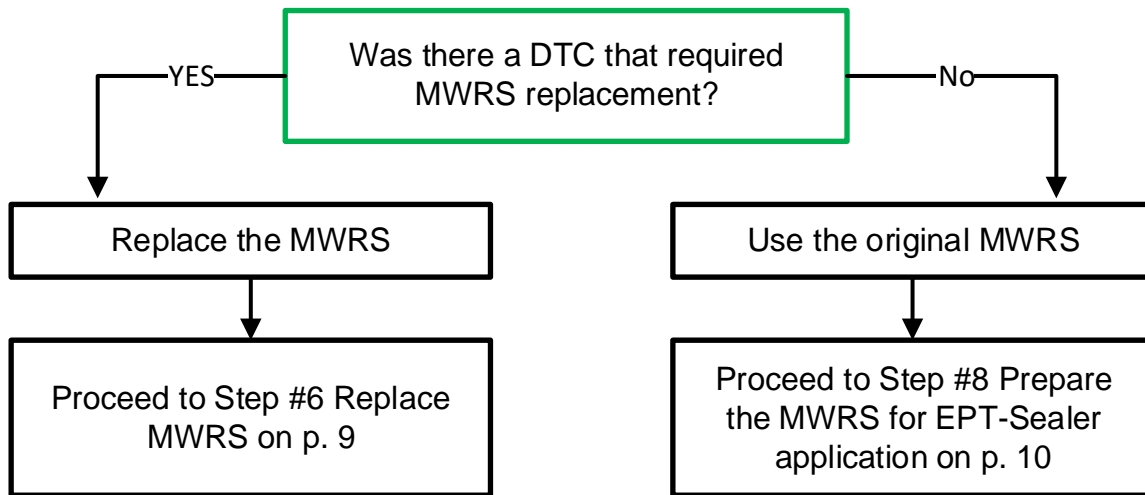

6. REPLACE MWRS (only if required)

- Remove the 2 bolts and screw.
- Remove the original MWRS.
- Install the **NEW** MWRS by engaging the 2 guides of the grille into the guide holes of the MWRS.
- Install the 2 bolts and screw.

Torque: 2.5 N·m (25 kgf·cm, 22 in.lbs)

7. DETERMINE IF EPT-SEALER IS NECESSARY FOR **NEW** SENSOR

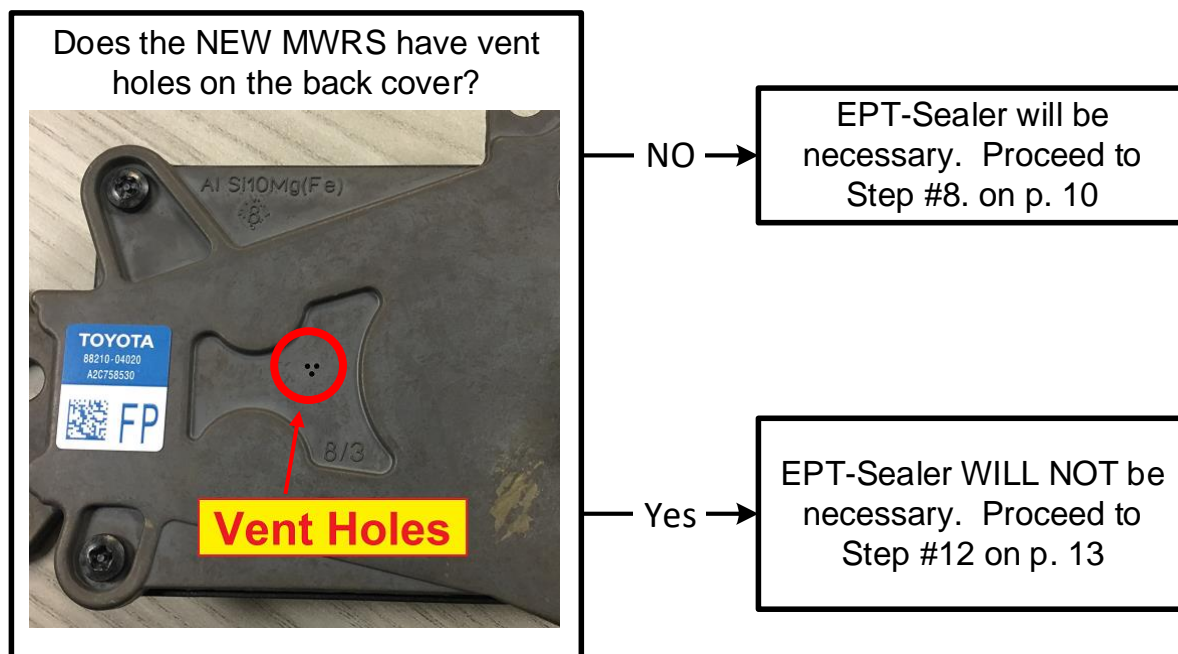

8. PREPARE THE MWRS FOR EPT-SEALER APPLICATION

- a. Place a blanket onto the table or workbench.
- b. Place the radiator grille onto the blanket, front side down.
- c. Using general purpose cleaner and a clean towel, clean the back side of the MWRS sensor and the emblem area on the back side of the grille.

9. DETERMINE GRILL TYPE

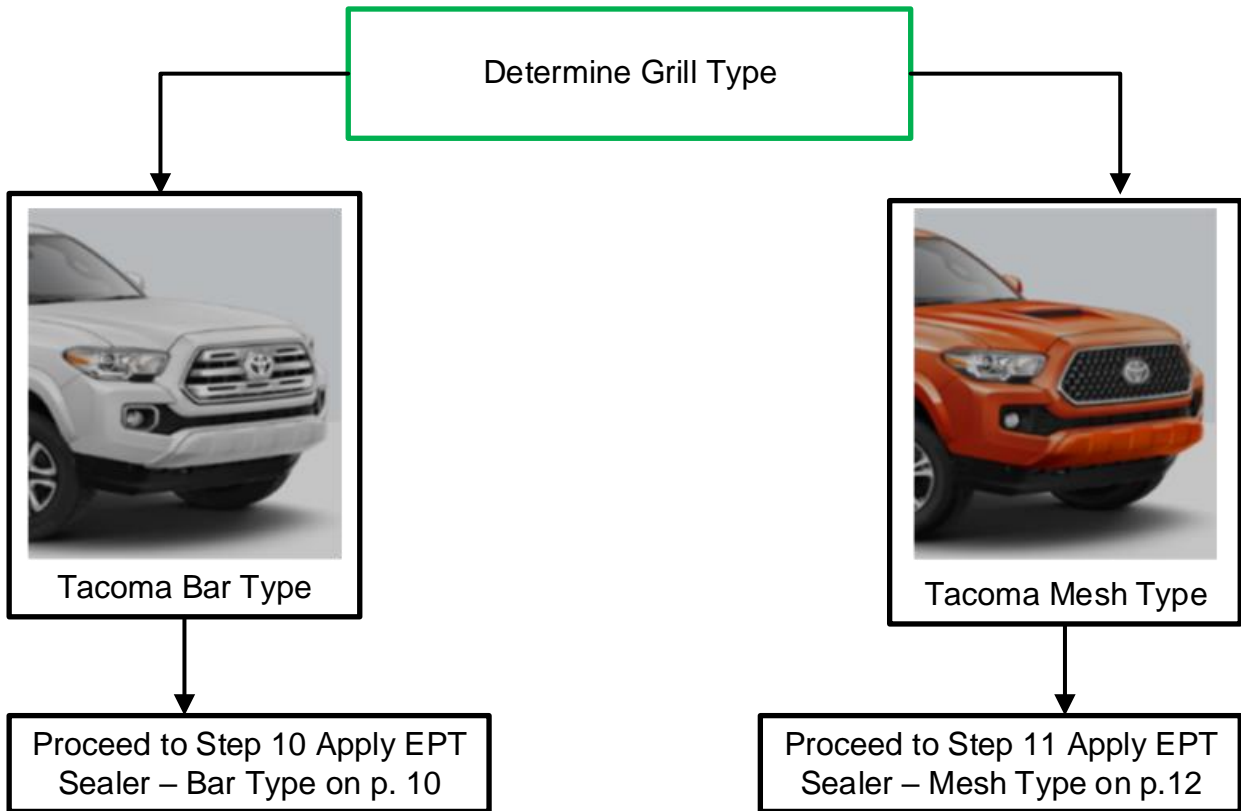

10. APPLY EPT-SEALER – Tacoma Bar Type

Note: This application will use P/N **88278-0C010**. (75mm x 150mm x 5mm)

This process is only for Tacoma's with the Bar type grill:



Video: Not available at this time

(cont.)

a. Apply the EPT Sealer to the back side of the MWRS in the position shown below:

- Start applying the EPT Sealer sheet to the vertical surface of the radiator grill, just above the MWRS.
- It will be necessary to push the EPT Sealer into the plastic tab at the top, creating a hole in the sealer.
- Wrap the EPT Sealer around the wire harness, as shown.
- Using heavy finger pressure, thoroughly press the entire surface of the EPT sealer to securely adhere it to all contact surfaces of the MWRS and grill.



Recommended temperature for adhesion is 50° F and above.
Keep stock at room temperature.

Continue to Step 12 on page 13

11. APPLY EPT-SEALER – Tacoma Mesh Type

Note: This application will use P/N **88278-0C010**. (75mm x 150mm x 5mm)

This process is only for Tacoma's with the Mesh type grill:



Video: [Tacoma Mesh Type Repair – EPT-Sealer Installation](#)

b. Apply the EPT Sealer to the back side of the MWRS in the position shown below:

- Start applying the EPT Sealer sheet to the horizontal lip of the radiator grill to create a waterproof shield over the top of the sensor.
- Using heavy finger pressure, thoroughly press the entire surface of the EPT sealer to securely adhere it to all contact surfaces of the MWRS.



Recommended temperature for adhesion is 50° F and above.
Keep stock at room temperature.

12. REINSTALL RADIATOR GRILLE

- c. Engage the 10 guides to install the radiator grille.
- d. Install the 2 clips.
- e. Install the 2 screws.
- f. Remove the protective tape.
- g. Engage the clamp.
- h. Connect the electrical connector.

13. DETERMINE IF MWRS ADJUSTMENT IS NECESSARY

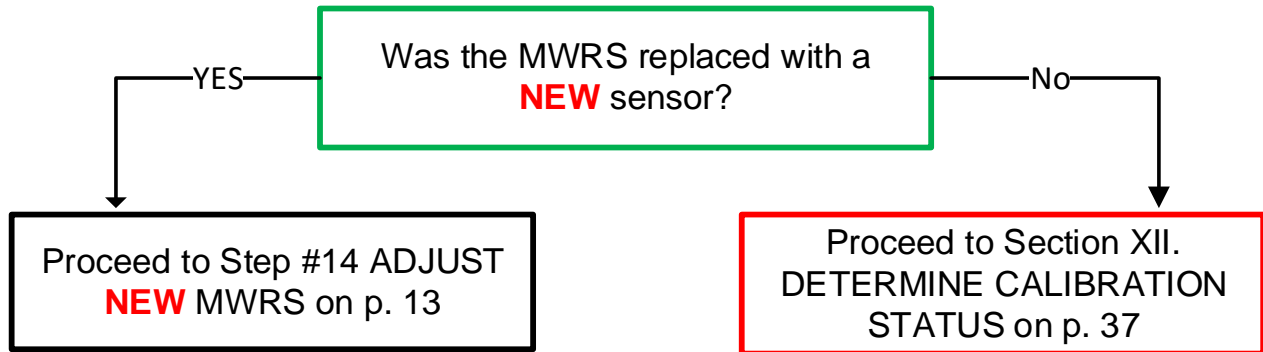

14. ADJUST NEW MWRS (only if required)

- i. Follow the Repair Manual procedure to complete the adjustment of the **NEW** MWRS.

[CRUISE CONTROL: MILLIMETER WAVE RADAR SENSOR: ADJUSTMENT](#)
(RM1000000018991)

Proceed to DETERMINE CALIBRATION STATUS on p. 37

VIII. TACOMA - REPAIR B

TACOMA Repair B vehicles will have a radiator grill of this design:



1. DETERMINE IF THE GRILL IS CORRECT FOR VEHICLE GRADE

- Using the Vehicle Inquiry tab on TIS, input the vehicles VIN and determine the **GRADE** of the vehicle trim.

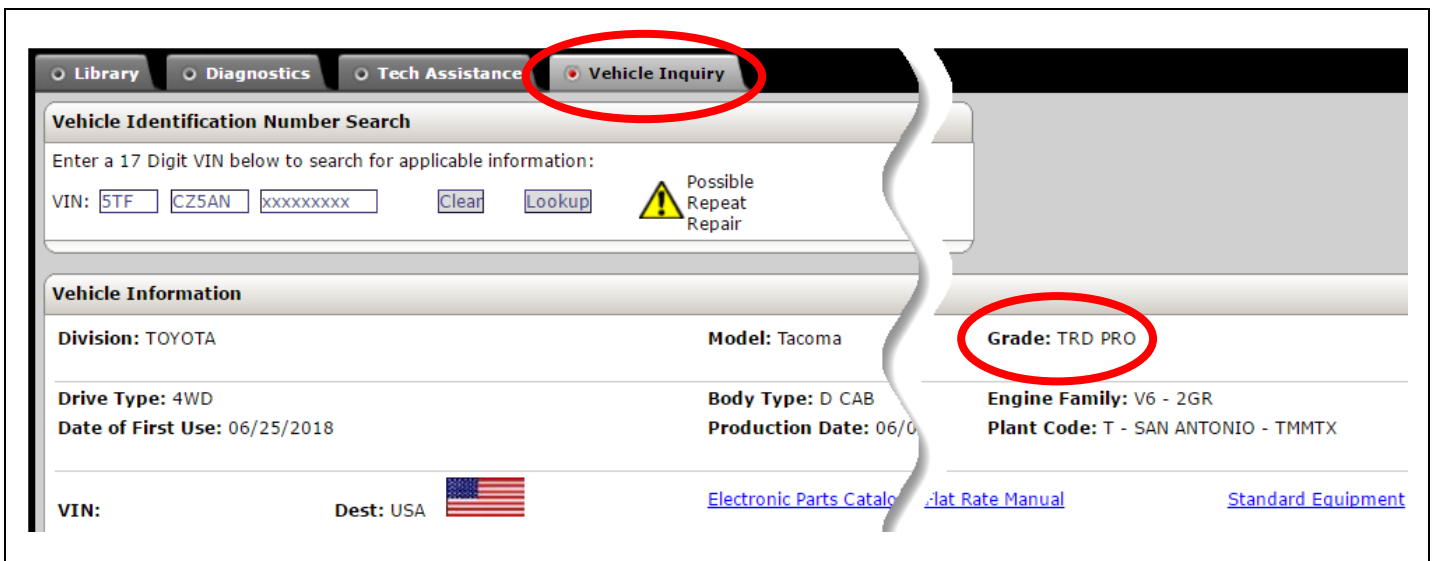

The screenshot displays the TIS (Technical Information System) interface for Vehicle Inquiry. The "Vehicle Inquiry" tab is selected and circled in red. Below the navigation tabs, there is a "Vehicle Identification Number Search" section with a text input field containing "5TF CZ5AN xxxxxxxx" and buttons for "Clear" and "Lookup". A warning icon indicates "Possible Repeat Repair".

The "Vehicle Information" section displays the following details:

Division: TOYOTA	Model: Tacoma	Grade: TRD PRO
Drive Type: 4WD	Body Type: D CAB	Engine Family: V6 - 2GR
Date of First Use: 06/25/2018	Production Date: 06/0	Plant Code: T - SAN ANTONIO - TMMTX

At the bottom, there are links for "Electronic Parts Catalog", "Flat Rate Manual", and "Standard Equipment". The "Dest: USA" is also indicated with a US flag icon.

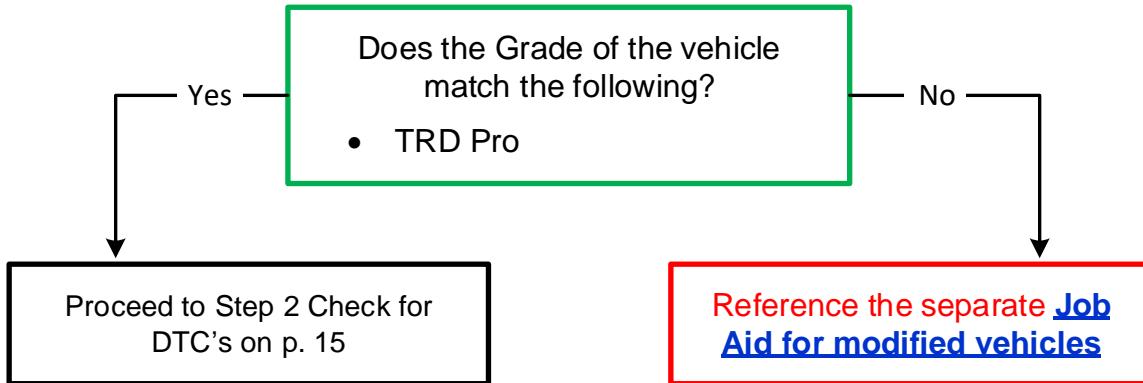

2. CHECK FOR DTC'S

- e. Using a Techstream, perform a Health Check.
- f. Are there any DTC's relating the Pre-Collision system (i.e. C1A10, U0235, U1104) as reported by any system?

Note: *This Service Campaign covers the application of the EPT-Sealer and Calibration ID update for the Pre-Collision 2 System, as detailed in these instructions. It will also cover the replacement cost of the Millimeter Wave Radar Sensor (MWRS), when necessary. It does not cover the diagnosis or replacement of any other parts on the vehicle.*

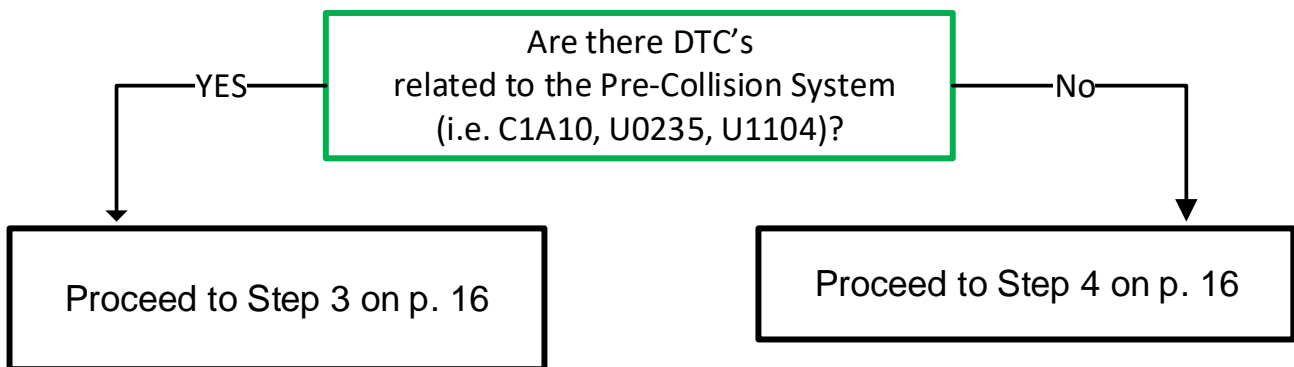

3. DETERMINE THE CAUSE OF PRE-COLLISION SYSTEM DTC'S (if present)

- b. Use the appropriate Repair Manual procedure to determine the cause of the Pre-Collision System DTC's, if present.

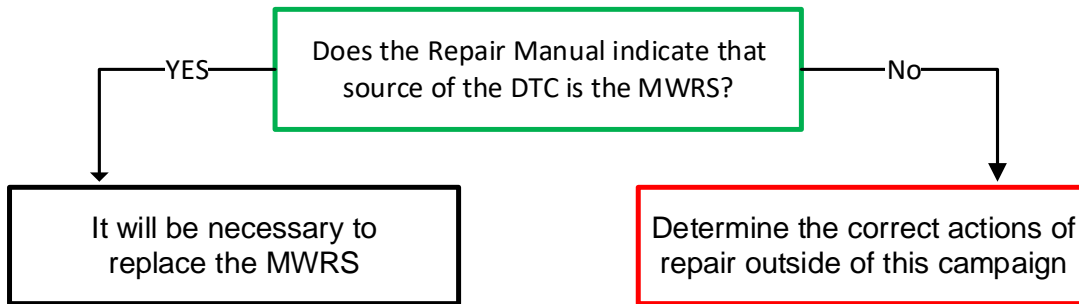

Note: Because there are multiple reasons that could cause Pre-Collision system failures, it's critical to diagnose the system to determine the source of the trouble. This campaign will only cover the replacement of the Millimeter Wave Radar Sensor, which is located behind the Toyota emblem of the radiator grill. If the diagnostic process identifies that the DTC's are caused by something other than the Millimeter Wave Radar Sensor, this campaign will not cover the cost associated with the repair.

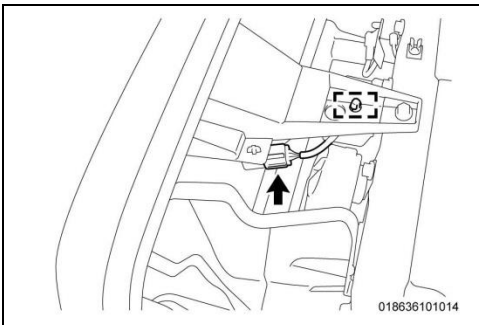

4. REMOVE RADIATOR GRILL

- a. Disconnect the electrical connector.
b. Disengage the clamp.

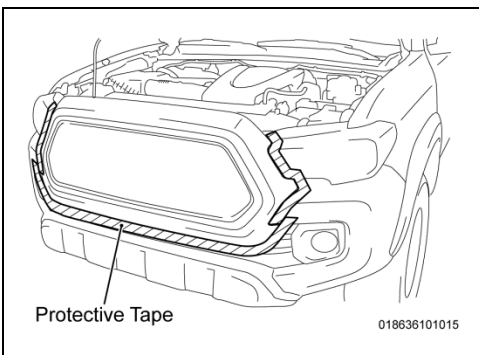

- c. Apply protective tape to the bumper around the radiator grille.

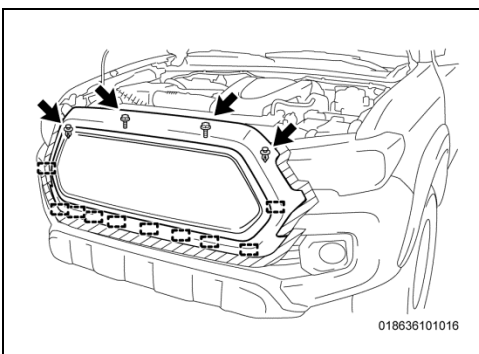

- d. Remove the 2 screws.
e. Remove the 2 clips.
f. Disengage the 10 guides by pulling the grille forward to disengage the remaining clips.

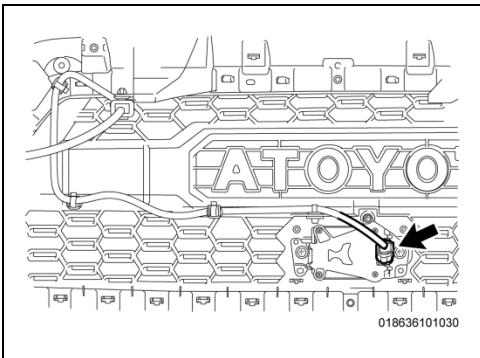

5. REMOVE MWRS FROM THE GRILLE

- a. Place a blanket onto a table or workbench.
- b. Place the radiator grille onto the blanket, front die down.
- c. Disconnect the electrical connector.

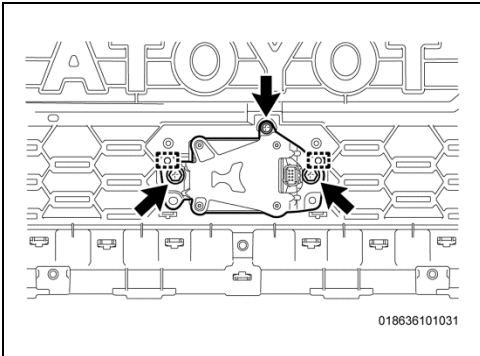

- d. Remove the 2 bolts and screw.
- e. Disengage the 2 guides and remove the MWRS from the grill.

6. DETERMINE IF A NEW MWRS IS REQUIRED

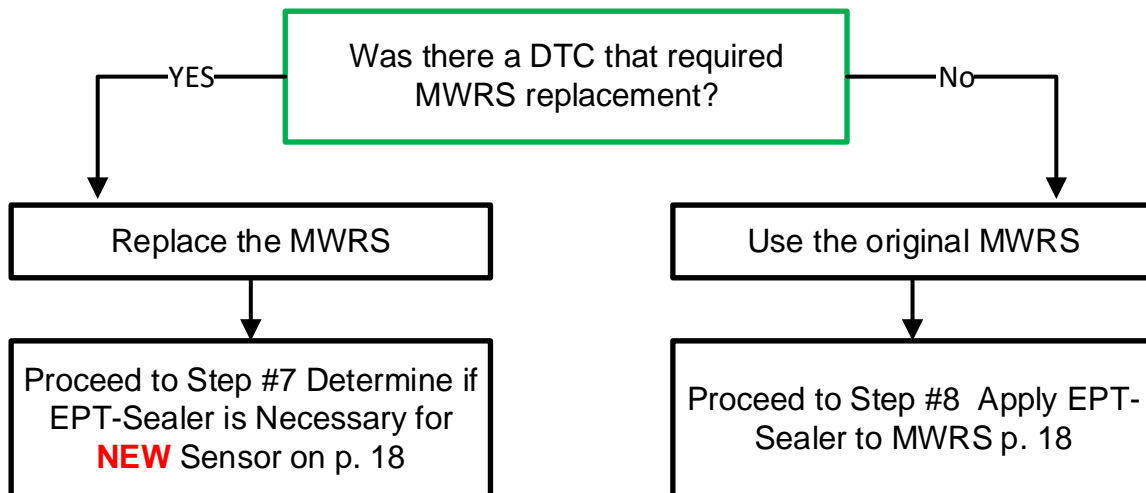

7. DETERMINE IF EPT-SEALER IS NECESSARY FOR **NEW** SENSOR

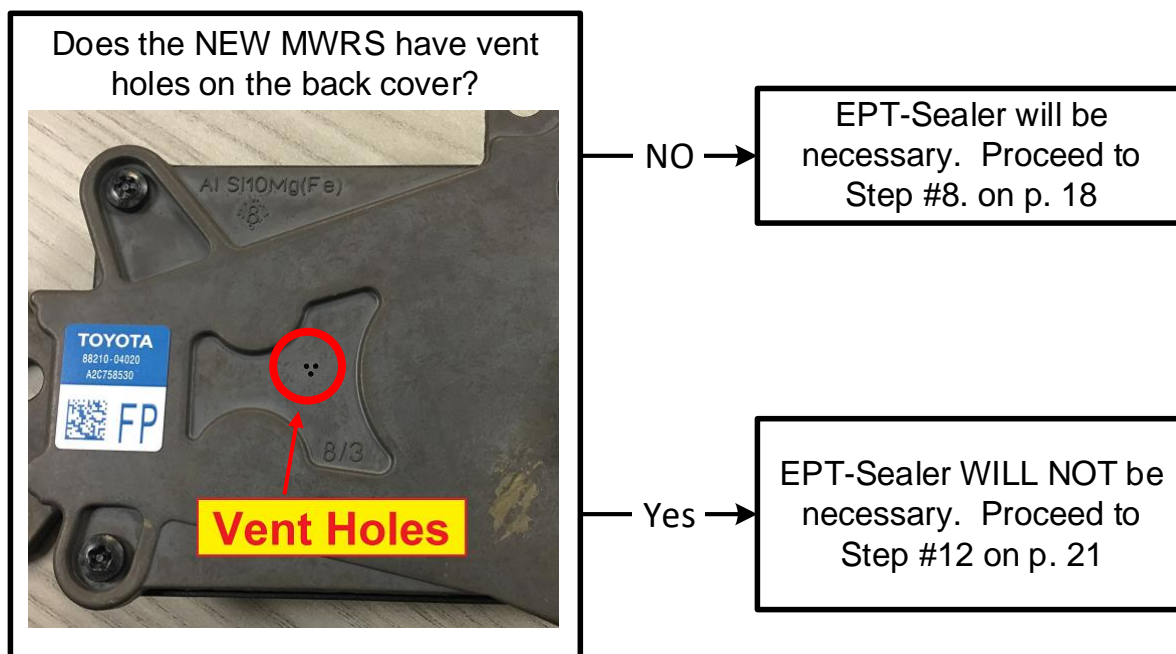

8. APPLY EPT-SEALER TO MWRS

Note: This application will use P/N **88278-0C020**. (46mm x 32mm x 5mm)

The EPT-Sealer will be applied in a specific way, using the following points for orientation. Please note the arrangement of corners A, B, C, D.

Video: [EPT Sealer Installation Repair B](#)

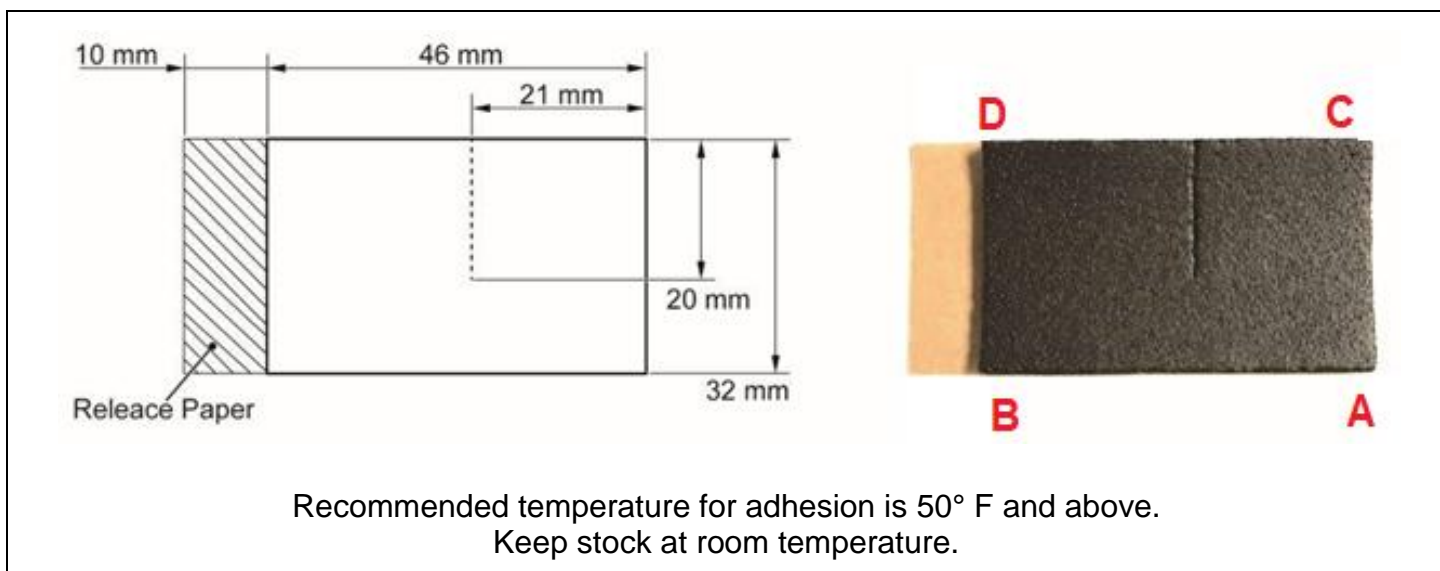

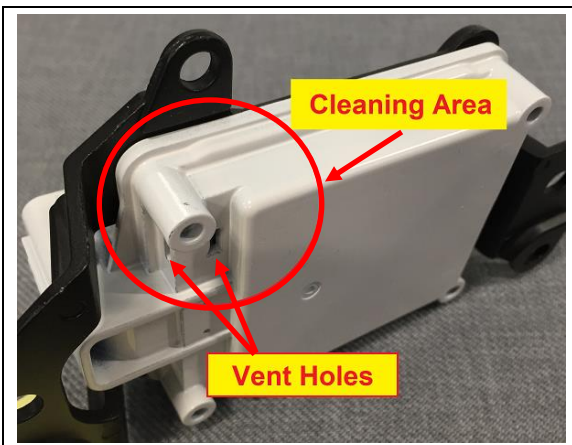

9. CLEAN THE APPLICATION AREA

- a. Using general purpose cleaner, remove all traces of dust, dirt, and oils or grease from the application area (indicated within the red circle). Be careful not to get any liquids into the 2 vent holes.

Note: The MWRS housing has been painted white in these photos to provide more contrast in the pictures. The actual MWRS housings will be black.

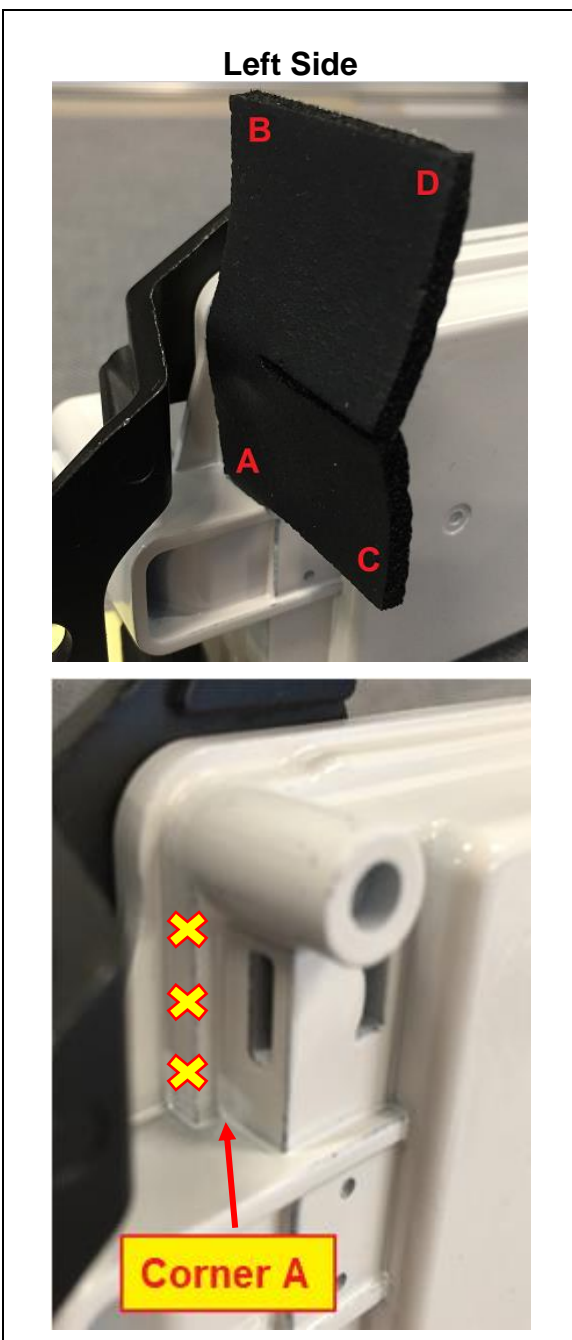

10. APPLY THE EPT SEALER

- a. Wear Nitrile Gloves to prevent adhesive contamination.
- b. Apply the EPT-Sealer to the left side of the MWRS to the following standard:
 - **Left Side View:** Corner “A” of the EPT-Sealer should be placed at the inner corner of the MWRS as indicated.
 - **Top View:** Place the EPT-Sealer on the surface of the side vent hole (it is ok to cover the side vent hole). **DO NOT place the EPT Sealer on top of the ridge**, as indicated with the yellow X’s.

Note: A diagram of the EPT sealer can be found on page 14.

- c. Press the EPT sealer firmly into place in this area to seat it thoroughly. Use a flathead screw driver or trim tool if necessary to reach the corner.

Top View

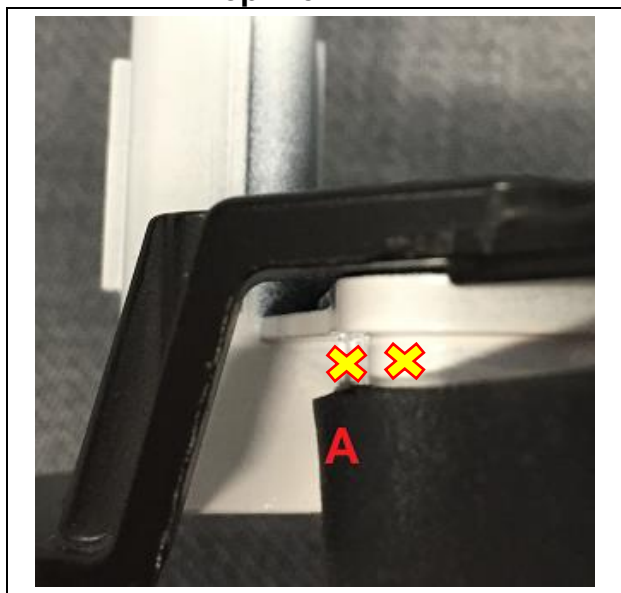

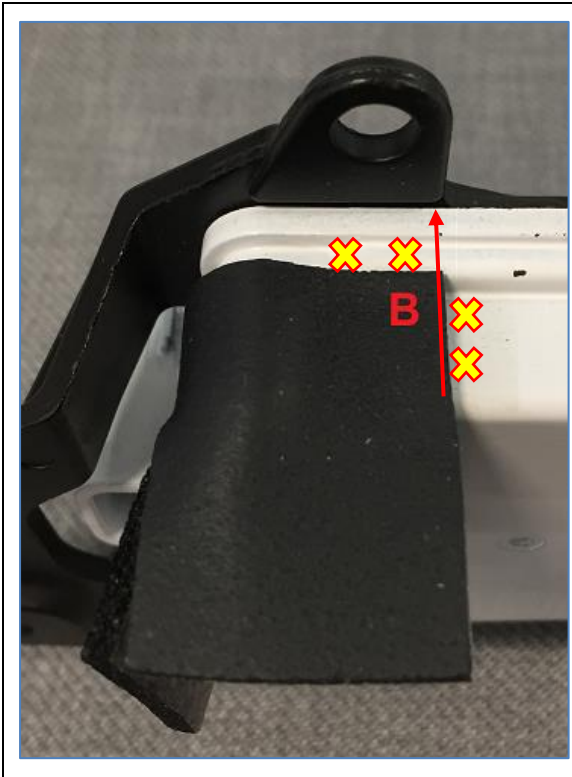

- d. Roll the EPT-Sealer Corner “B” onto the top edge of the MWRS sensor as shown, **aligning it’s edge with the end of the metal bracket. Be sure to keep the EPT-Sealer off the upper ridge.**
- e. Press the EPT sealer firmly into place in this area to seat it thoroughly.

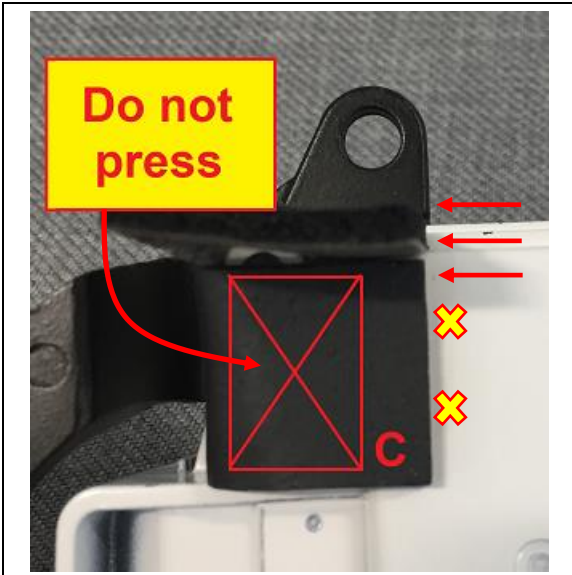

- f. Bend the lower flap (Corner “C”) onto the face of the MWRS and align the edge with the edge of the upper flap and metal bracket.
- g. Press the EPT-Sealer into the face of the MWRS to seat it firmly. **DO NOT** press in the area indicated as it’s critical there is an air gap for the vent.

	<p>ONLY PRESS THE EPT-SEALER ONTO THE UPPER FACE OF THE MWRS. DO NOT press the EPT sealer into the vent hole. It’s critical that the vent hole remains open.</p>
---	---

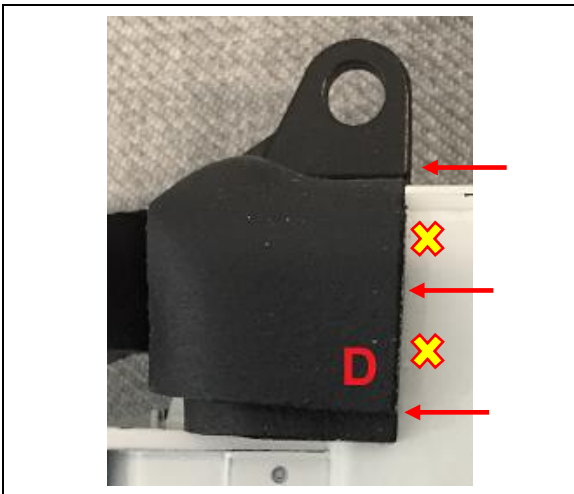

- h. Roll Corner “D” downward from the top, aligning the edge with the edge of the lower section and metal bracket.
- i. Press the EPT sealer into place, being careful to leave an airgap above the rear vent hole.

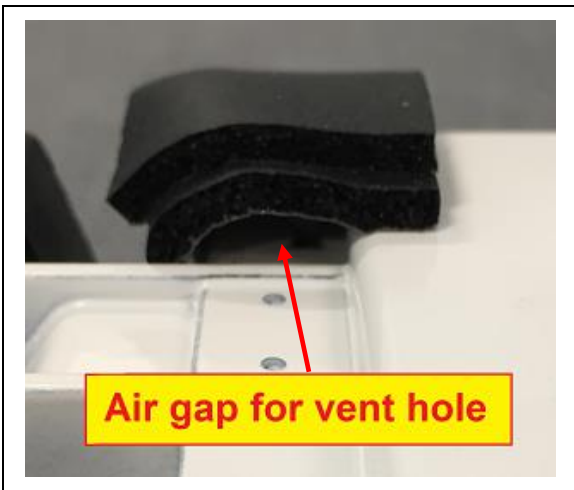

11. INSPECT THE EPT-SEALER APPLICATION

- a. Verify that all the contact points of the EPT sealer are thoroughly applied.
- b. Verify that the bottom is still open to properly allow airflow to the rear vent hole.

Note: In case of failure during inspection, start over with a new piece of EPT-Sealer.

12. INSTALL THE MWRS

- a. Engage the 2 guides of the radiator grille into the guide holes of the MWRS.
- b. Install the 2 bolts and screw.

Torque: 2.5 N·m (25 kgf·cm, 22 in.lbs)

13. REINSTALL THE RADIATOR GRILLE

- a. Engage the 10 guides to install the radiator grille.
- b. Install the 2 clips.
- c. Install the 2 screws.
- d. Remove the protective tape.
- e. Engage the clamp.
- f. Connect the electrical connector.

14. ADJUST THE MWRS

- a. Follow the Repair Manual procedure to properly adjust the MWRS.

[CRUISE CONTROL: MILLIMETER WAVE RADAR SENSOR: ADJUSTMENT](#)

(RM1000000018991)

Proceed to DETERMINE CALIBRATION STATUS on p. 37

IX. TUNDRA - REPAIR A

TUNDRA Repair A vehicles will have a radiator grill of this design:



1. DETERMINE IF THE GRILL IS CORRECT FOR VEHICLE GRADE

- Using the Vehicle Inquiry tab on TIS, input the vehicles VIN and determine the **GRADE** of the vehicle trim.

A screenshot of the TIS (Toyota Information System) interface. The 'Vehicle Inquiry' tab is selected and circled in red. Below the search bar, the 'Vehicle Information' section displays the following details: Division: TOYOTA, Model: Tundra, Grade: SR5 (circled in red), Drive Type: 2WD, Body Type: Extended, Engine Family: V8 - 1UR-FE, Date of First Use: 12/19/2017, Production Date: 08, and Plant Code: T - SAN ANTONIO - TMMTX. At the bottom, there are links for 'Electronic Parts Catalog', 'Flat Rate Manual', and 'Standard Equipment'. A warning icon and text 'Possible Repeat Repair' are also visible.

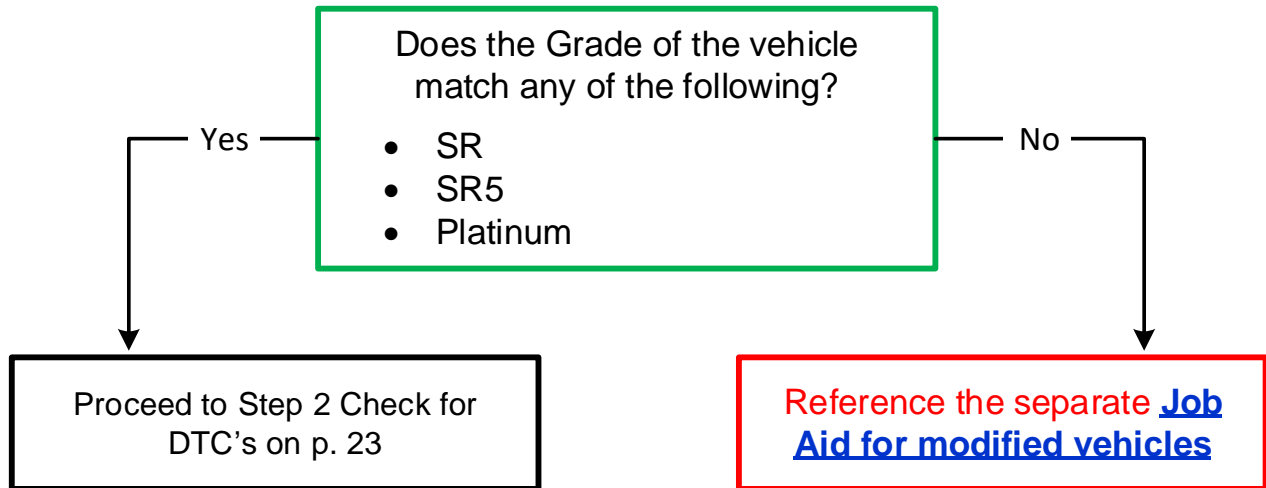

2. CHECK FOR DTC'S

- Using a Techstream, perform a Health Check.
- Are there any DTC's relating the Pre-Collision system (i.e. C1A10, U0235, U1104) as reported by any system?

Note: This Service Campaign covers the application of the EPT-Sealer and Calibration ID update for the Pre-Collision 2 System, as detailed in these instructions. It will also cover the replacement cost of the Millimeter Wave Radar Sensor (MWRS), when necessary. It does not cover the diagnosis or replacement of any other parts on the vehicle.

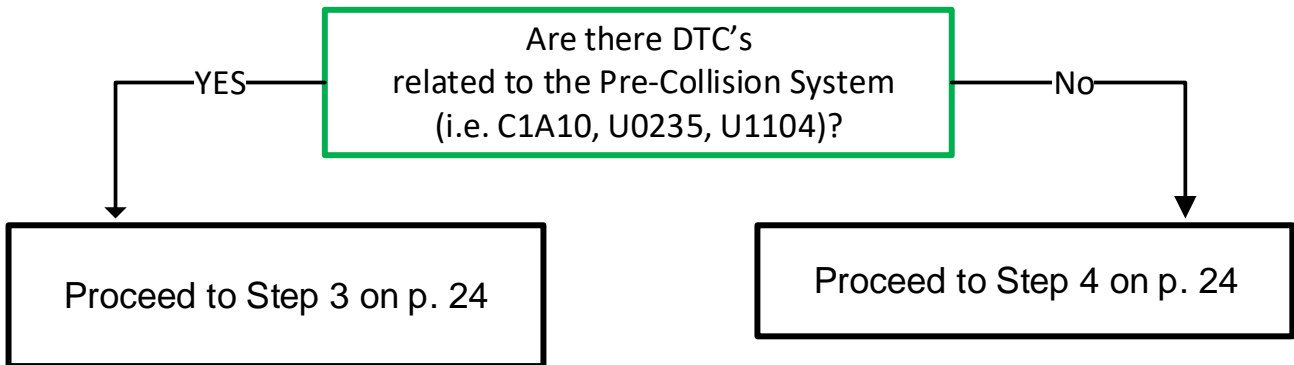

3. DETERMINE THE CAUSE OF PRE-COLLISION SYSTEM DTC'S (if present)

- a. Use the appropriate Repair Manual procedure to determine the cause of the Pre-Collision System DTC's, if present.

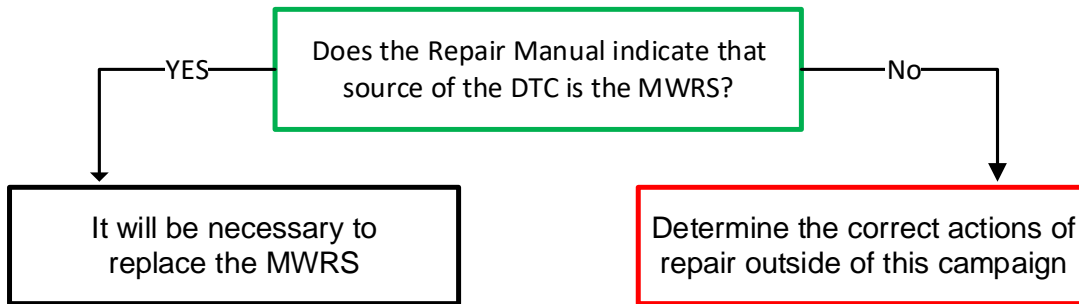

Note: Because there are multiple reasons that could cause Pre-Collision system failures, it's critical to diagnose the system to determine the source of the trouble. This campaign will only cover the replacement of the Millimeter Wave Radar Sensor, which is located behind the Toyota emblem of the radiator grill. If the diagnostic process identifies that the DTC's are caused by something other than the Millimeter Wave Radar Sensor, this campaign will not cover the cost associated with the repair.

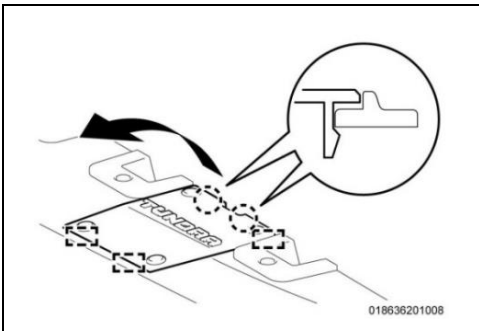

4. REMOVE RADIATOR GRILL

- a. Detach the 2 claws and 3 guides to remove the cover.
- b. Disconnect the electrical connector under the cover.

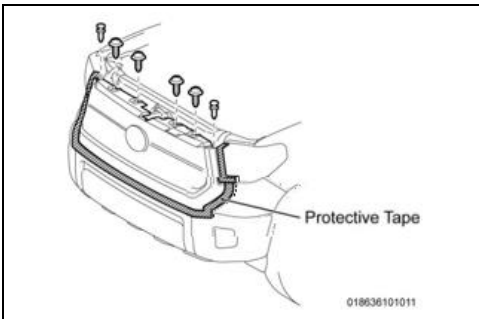

- c. Place protective tape on the front bumper and headlights, at the edge of the grill assembly, to protect the surfaces during removal and installation.
- d. Remove the 4 screws and 2 clips

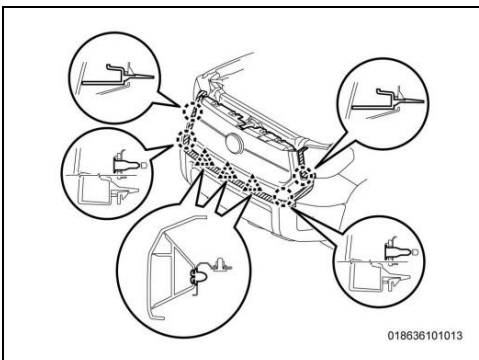

- e. Detach the 4 claws and 3 clips by pulling the grill assembly forward.

5. DETERMINE IF A NEW MWRS IS REQUIRED

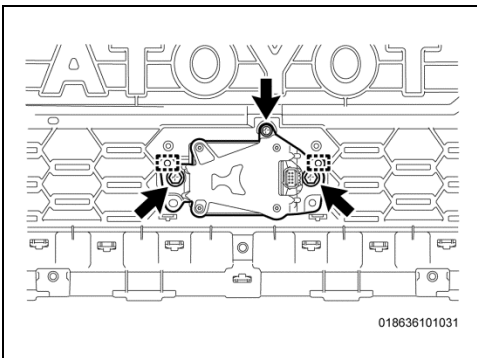
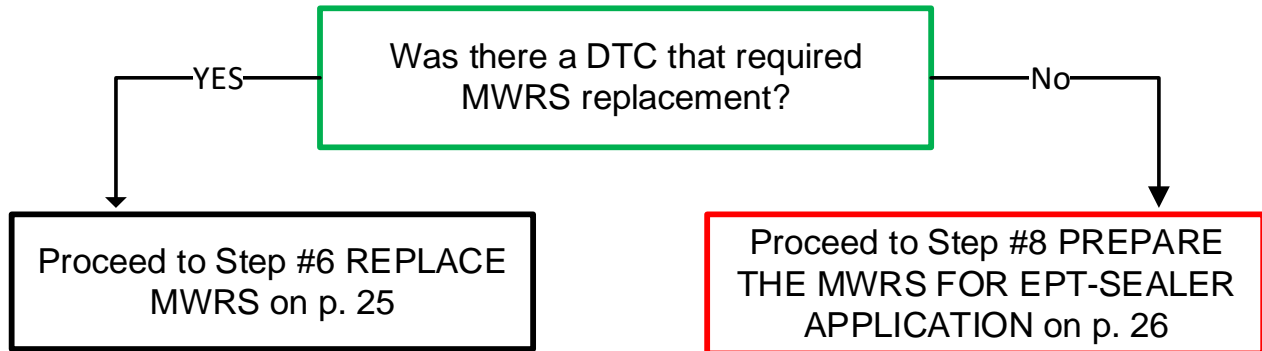

6. REPLACE MWRS (only if required)

- Remove the 2 bolts and screw.
- Remove the original MWRS.
- Install the **NEW** MWRS by engaging the 2 guides of the grille into the guide holes of the MWRS.
- Install the 2 bolts and screw.

Torque: 2.5 N·m (25 kgf·cm, 22 in.lbs)

7. DETERMINE IF EPT-SEALER IS NECESSARY FOR **NEW** SENSOR

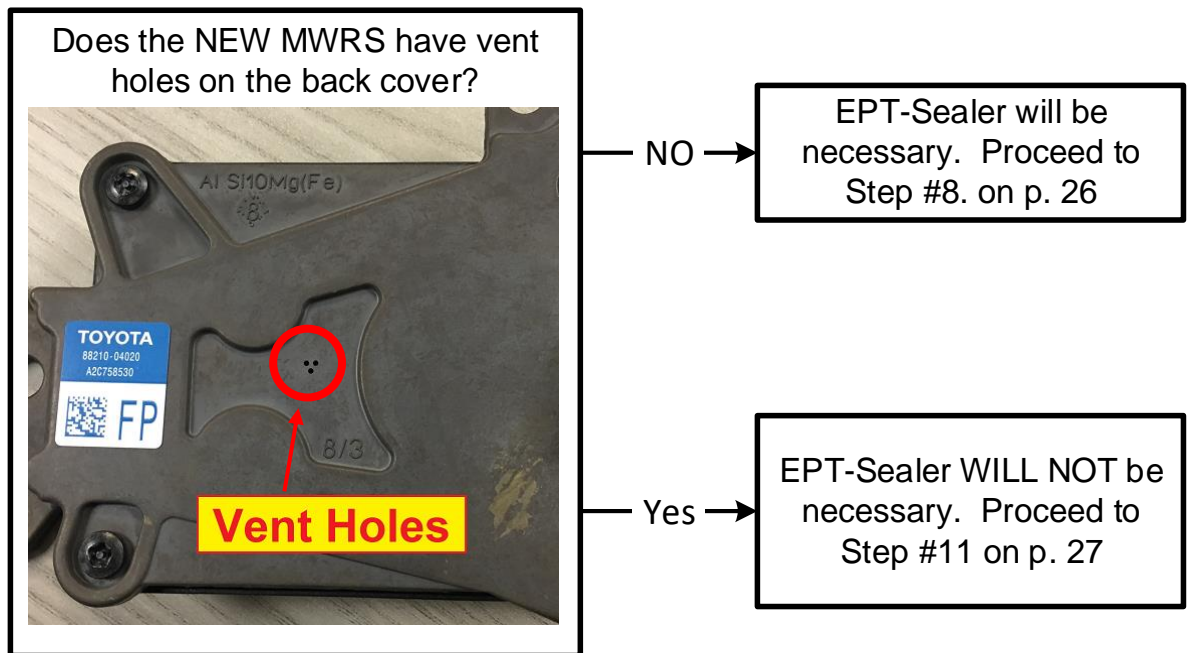

8. PREPARE THE MWRS FOR EPT APPLICATION

- Place a blanket onto the table or workbench.
- Place the radiator grille onto the blanket, front side down.
- Using general purpose cleaner and a clean towel, clean the back side of the MMRS sensor and the emblem area on the back side of the grille.

9. APPLY EPT-SEALER

Note: This application will use P/N **88278-0C010**. (75mm x 150mm x 5mm)

Video: [Tundra EPT Sealer Installation Type A](#)

- Apply the EPT Sealer to the back face of the MWRS in the position shown below.
- Roll the EPT sealer onto the inside lip of the radiator grill to create a waterproof shield over the top of the sensor.
- Using finger pressure, thoroughly press the entire surface of the EPT sealer to securely adhere it to all contact surfaces.



Recommended temperature for adhesion is 50° F and above.
Keep stock at room temperature.

10. REINSTALL THE RADIATOR GRILL

- Attach the 4 claws and 3 clips to install the grille.
- Install the 4 screws and 2 clips.
- Remove the protective tape.
- Connect the electrical connector.
- Reinstall the cover.

11. DETERMINE IF MWRS ADJUSTMENT IS NECESSARY

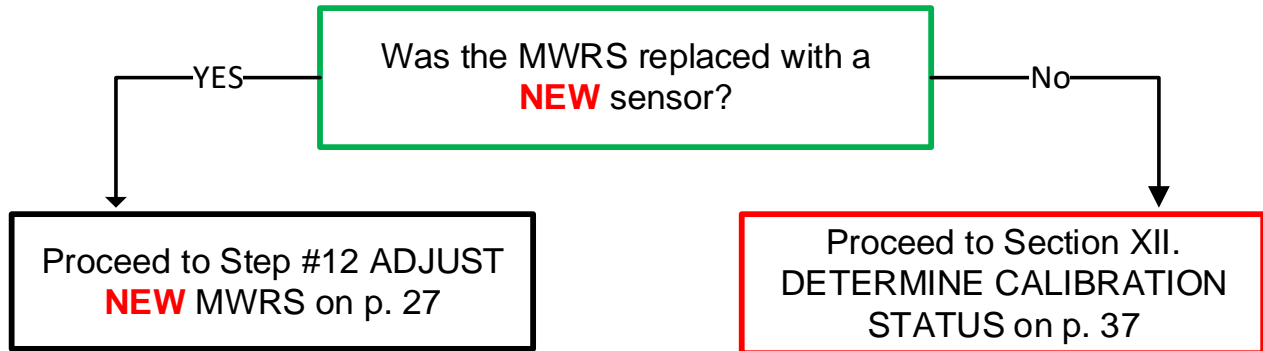

12. ADJUST NEW MWRS (only if required)

- a. Follow the Repair Manual procedure to complete the adjustment of the **NEW** MWRS.

[CRUISE CONTROL: MILLIMETER WAVE RADAR SENSOR: ADJUSTMENT](#)

(RM1000000015LKF)

Proceed to DETERMINE CALIBRATION STATUS on p. 37

X. TUNDRA - REPAIR B

TUNDRA Repair B vehicles will have radiator grills of these designs:



1. DETERMINE IF THE GRILL IS CORRECT FOR VEHICLE GRADE

- Using the Vehicle Inquiry tab on TIS, input the vehicles VIN and determine the **GRADE** of the vehicle trim.



Library Diagnostics Tech Assistance **Vehicle Inquiry**

Vehicle Identification Number Search

Enter a 17 Digit VIN below to search for applicable information:

VIN:  Possible Repeat Repair

Vehicle Information

Division: TOYOTA	Model: Tacoma	Grade: SR5
Drive Type: 2X4	Body Type: D CAB	Engine Family: V6 - 2GR
Date of First Use: 07/12/2018	Production Date: 07/12/2018	Plant Code: Q - BAJA CALIFORNIA - TMMBC

VIN: Dest: USA  [Electronic Parts Catalog](#) [Flat Rate Manual](#) [Standard Equipment \[+\]](#)

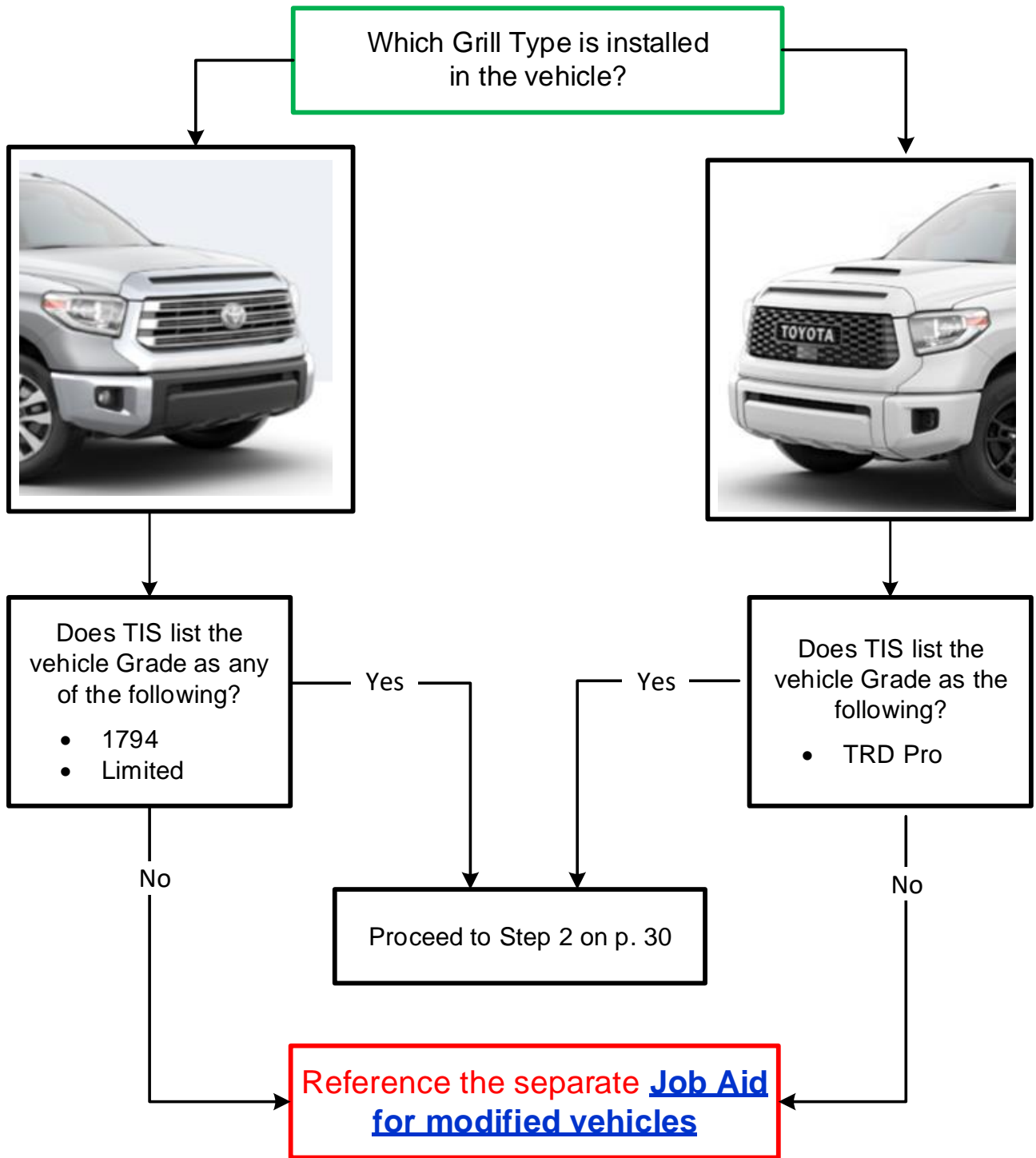



2. CHECK FOR DTC'S

- a. Using a Techstream, perform a Health Check.
- b. Are there any DTC's relating the Pre-Collision system (i.e. C1A10, U0235, U1104) as reported by any system?

Note: *This Service Campaign covers the application of the EPT-Sealer and Calibration ID update for the Pre-Collision 2 System, as detailed in these instructions. It will also cover the replacement cost of the Millimeter Wave Radar Sensor (MWRS), when necessary. It does not cover the diagnosis or replacement of any other parts on the vehicle.*

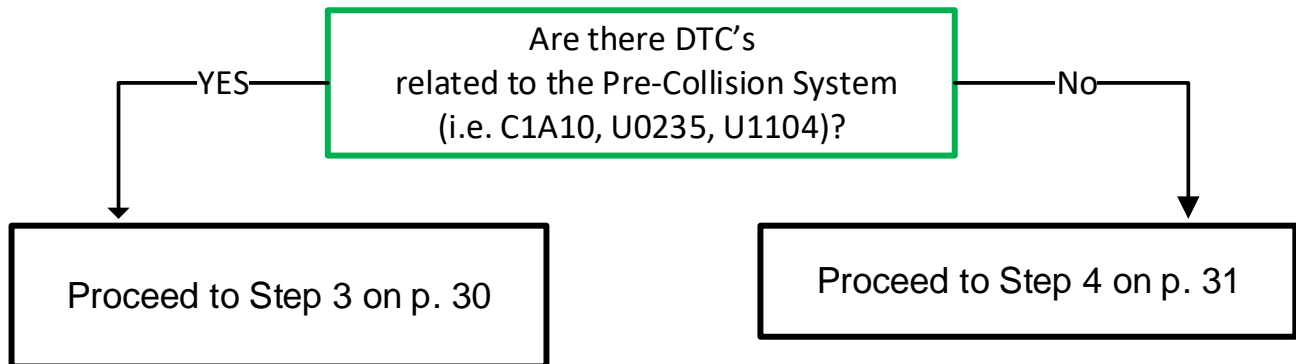

3. DETERMINE THE CAUSE OF PRE-COLLISION SYSTEM DTC'S (if present)

- b. Use the appropriate Repair Manual procedure to determine the cause of the Pre-Collision System DTC's, if present.

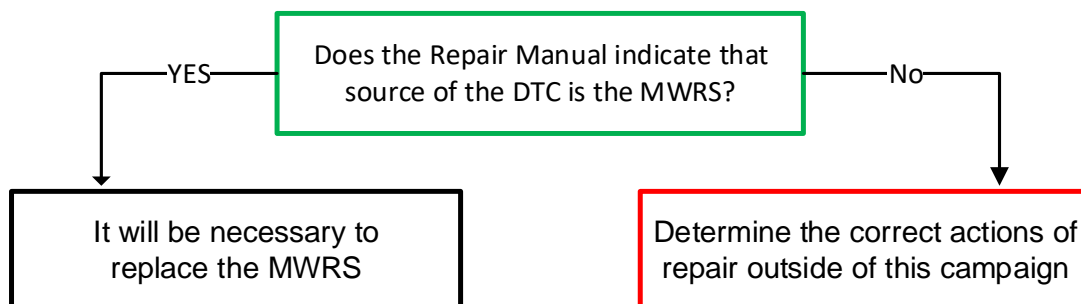

Note: Because there are multiple reasons that could cause Pre-Collision system failures, it's critical to diagnose the system to determine the source of the trouble. This campaign will only cover the replacement of the Millimeter Wave Radar Sensor, which is located behind the Toyota emblem of the radiator grill. If the diagnostic process identifies that the DTC's are caused by something other than the Millimeter Wave Radar Sensor, this campaign will not cover the cost associated with the repair.

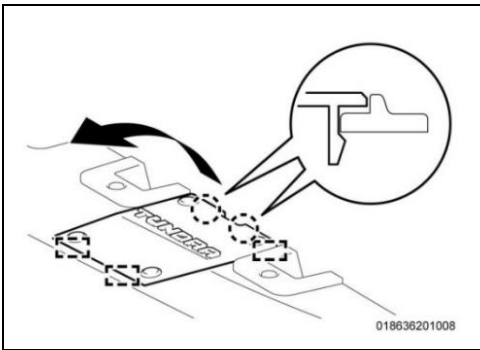

4. REMOVE RADIATOR GRILL

- a. Detach the 2 claws and 3 guides to remove the side grill.
- b. Disconnect the electrical connector under the cover.

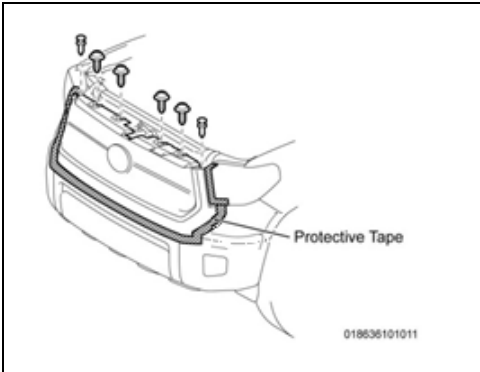

- c. Place protective tape on the front bumper and headlights, at the edge of the grill assembly, to protect the surfaces during removal and installation.
- d. Remove the 4 screws and 2 clips

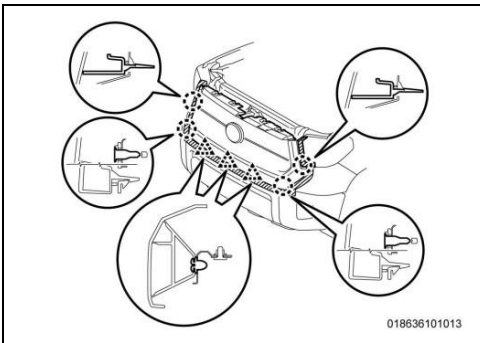

- e. Detach the 4 claws and 3 clips by pulling the grill assembly forward.
- f. Place a blanket onto the table or workbench.
- g. Place the radiator grill onto the blanket, front side down.

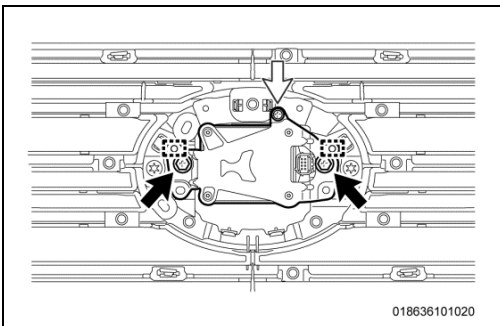

5. REMOVE MWRS FROM GRILL

- a. Disconnect the electrical connector.
- b. Remove the 2 bolts and 1 screw.
- c. Remove the MWRS from the radiator grill.

6. DETERMINE IF A NEW MWRS IS REQUIRED

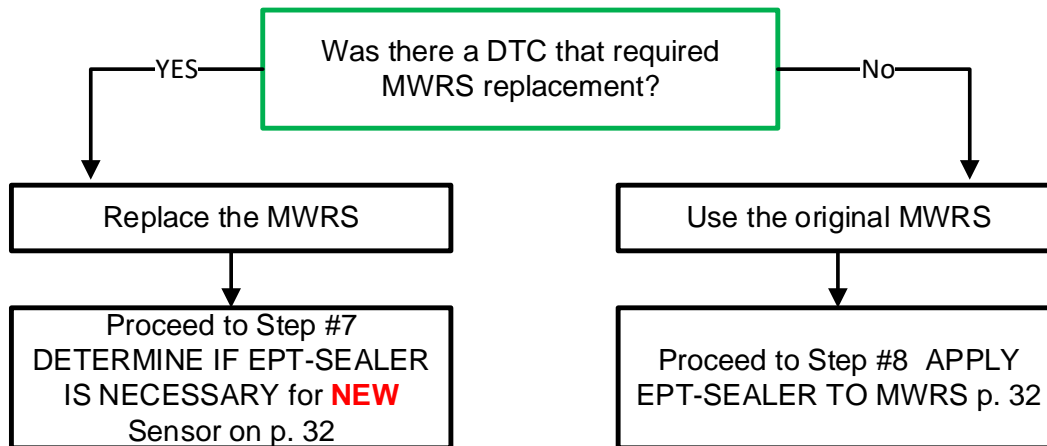

7. DETERMINE IF EPT-SEALER IS NECESSARY FOR **NEW** SENSOR

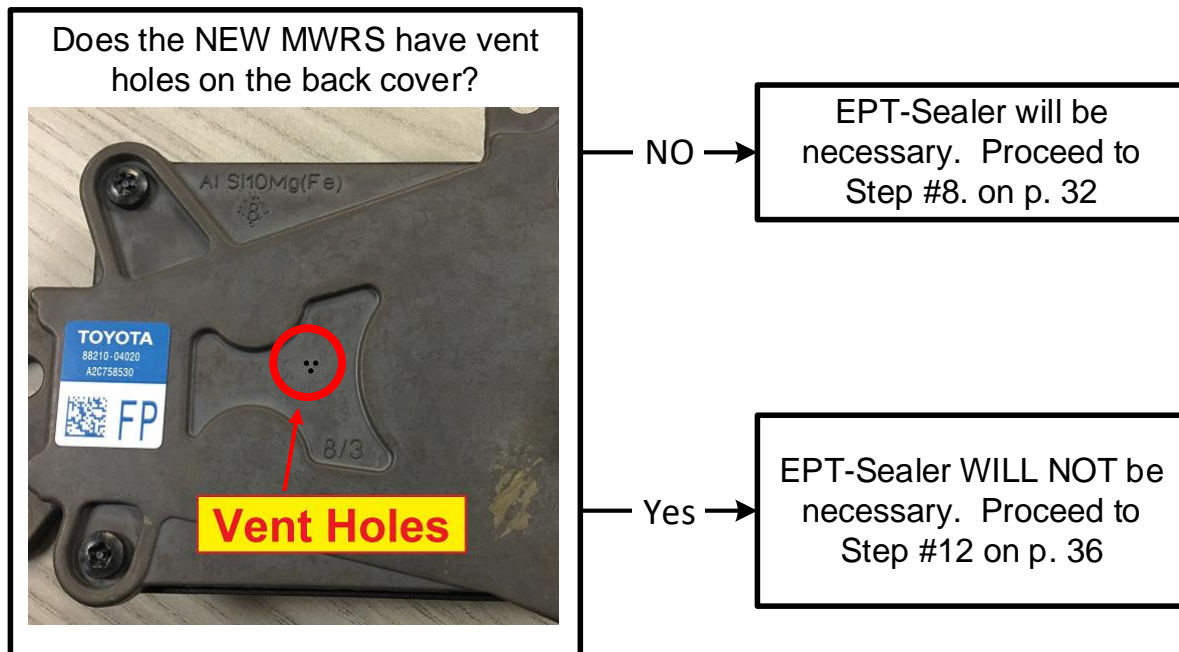

8. APPLY EPT-SEALER TO MWRS

Note: This application will use P/N **88278-0C020**. (46mm x 32mm x 5mm)

The EPT-Sealer will be applied in a specific way, using the following points for orientation. Please note the arrangement of corners A, B, C, D.

Video: [EPT Sealer Installation Repair B](#)

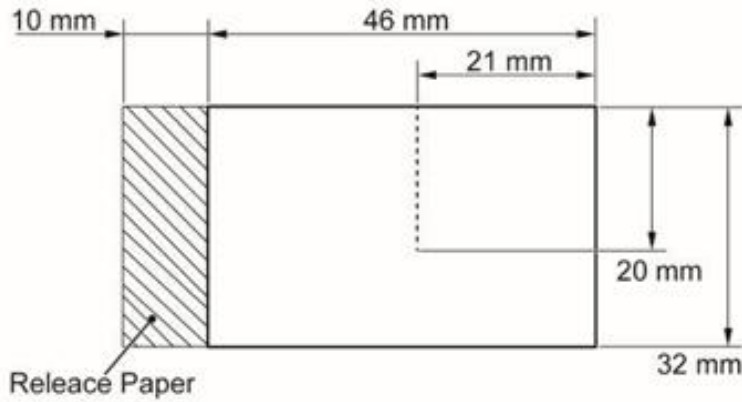

Recommended temperature for adhesion is 50° F and above.
Keep stock at room temperature.

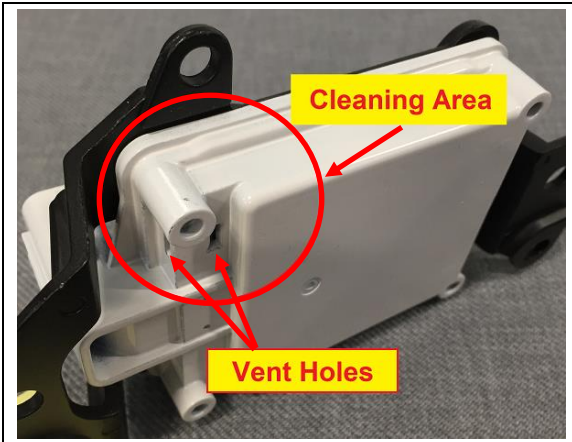

9. CLEAN THE APPLICATION AREA

- a. Using general purpose cleaner, remove all traces of dust, dirt, and oils or grease from the application area (indicated within the red circle). Be careful not to get any liquids into the 2 vent holes.

Note: The MWRS housing has been painted white in these photos to provide more contrast in the pictures. The actual MWRS housings will be black.

Left Side

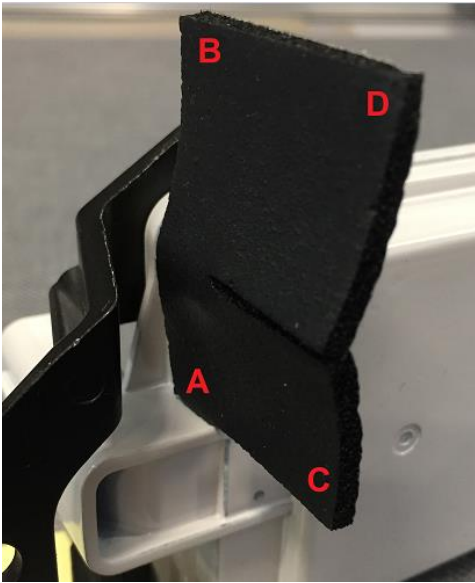

10. APPLY THE EPT SEALER

- a. Wear Nitrile Gloves to prevent adhesive contamination.
- b. Apply the EPT-Sealer to the left side of the MWRS to the following standard:
 - **Left Side View:** Corner "A" of the EPT-Sealer should be placed at the inner corner of the MWRS as indicated.
 - **Top View:** Place the EPT-Sealer on the surface of the side vent hole (it is ok to cover the side vent hole). **DO NOT place the EPT Sealer on top of the ridge**, as indicated with the yellow X's.

Note: A diagram of the EPT sealer can be found on page 15.

- c. Press the EPT sealer firmly into place in this area to seat it thoroughly. Use flathead screw driver or trim tool if necessary to reach the corner.

Top View

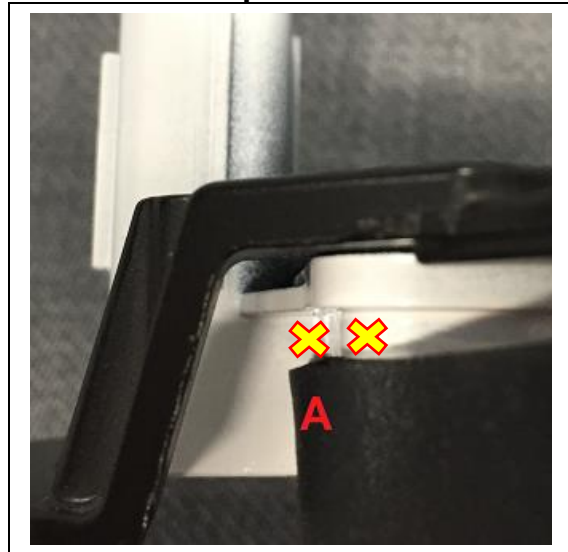



- d. Roll the EPT-Sealer Corner "B" onto the top edge of the MWRS sensor as shown, **aligning its edge with the end of the metal bracket. Be sure to keep the EPT-Sealer off the upper ridge.**
- e. Press the EPT sealer firmly into place in this area to seat it thoroughly.

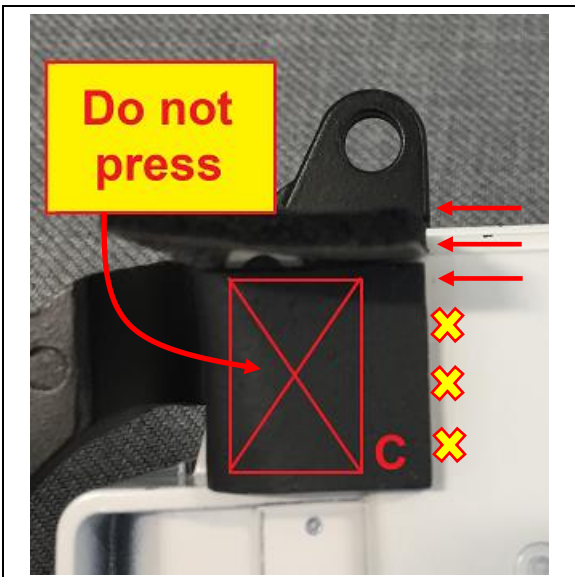

- f. Bend the lower flap (Corner "C") onto the face of the MWRS and align the edge with the edge of the upper flap and metal bracket.
- g. Press the EPT-Sealer into the face of the MWRS to seat it firmly. **DO NOT** press in the area indicated as it's critical there is an air gap for the vent.

	<p>ONLY PRESS THE EPT SEALER ONTO THE FACE OF THE MWRS. DO NOT press the EPT sealer into the vent hole. It's critical that the vent hole remains open.</p>
---	---

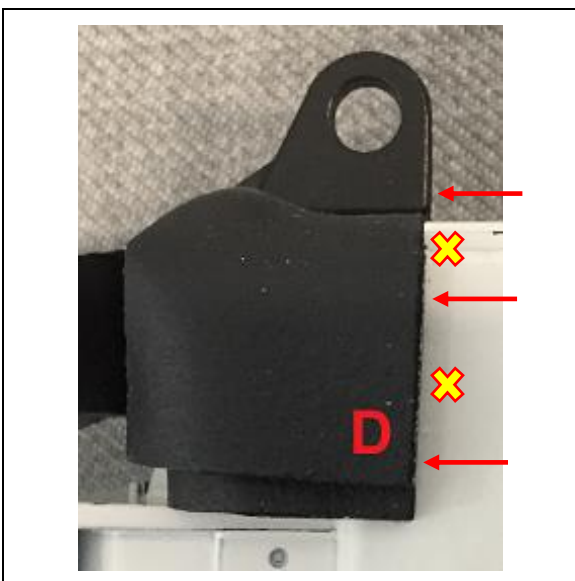

- h. Roll Corner "D" downward from the top, aligning the edge with the edge of the lower section and metal bracket.
- i. Press the EPT sealer into place, being careful to leave an airgap above the rear vent hole.

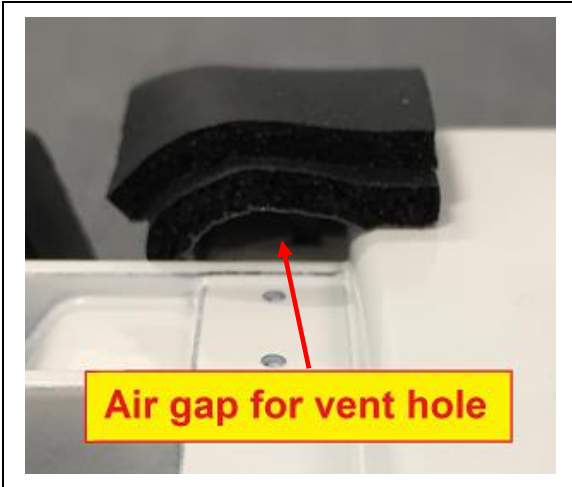

11. INSPECT THE EPT-SEALER APPLICATION

- a. Verify that all the contact points of the EPT sealer are thoroughly applied.
- b. **Verify that the bottom is still open to properly allow airflow to the rear vent hole.**

Note: In case of failure during inspection, start over with a new piece of EPT-Sealer.

12. REINSTALL THE MWRS

- a. Engage the 2 guides of the grille into the guide holes of the MWRS.
- b. Install the 2 bolts and screw.

Torque: 2.5 N·m (25 kgf·cm, 22 in.lbs)

13. REINSTALL THE RADIATOR GRILLE

- a. Engage the 4 claws and 3 clips to install the radiator grill assembly.
- b. Install the 4 screws and 2 clips.
- c. Remove the protective tape.
- d. Connect the electrical connector.
- e. Install the Side Grill by engaging the 2 claws and 3 guides.

14. ADJUST THE MWRS

- a. Follow the Repair Manual procedure to properly calibrate the MWRS after re-installation.

[CRUISE CONTROL: MILLIMETER WAVE RADAR SENSOR: ADJUSTMENT](#)

(RM1000000015LKF)

XI. DETERMINE CALIBRATION STATUS



1. CHECK FOR DTC'S

- a. Using a Techstream, perform a Health Check.

Note: This Service Campaign covers only the application of the EPT-Sealer and Calibration ID update for the Pre-Collision 2 System, as detailed in these instructions. It does not cover the diagnosis or replacement of any other parts on the vehicle.

2. CHECK CURRENT CALIBRATION

- a. Locate the Update column for the **Pre-Collision 2** System in the Stored Data tab.
- b. Determine the status of an available update; indicated by a **Yes** or **No**.

System Select **Stored Data**

2018 Tundra
3UR-FE

016018 mile
Production Date
- 10/2017

2018_Tundra_3U
File Notes
Health Check
Data 1-1/2

Tire Pressure / Threshold Value [psi(gau

Sensor 1: 37.66 / 27.68 Sensor 2:
Sensor 3: 37.41 / 27.68 Sensor 4:
Sensor 5: 37.66 / 27.68

Health Check Results

- Health Check does not display live data.
- Changes in vehicle condition will not update
- To update Health Check, click the Refresh bu

Enhanced | Generic |

Campaign Status: **OPEN**
PERMANENT: **NO**

System	SB	RoB	Calibration	Update
Tilt&Telescopic	-	-	-	
SRS Airbag	-	-	8917F0C035	No
Navigation System	-	-	-	
Pre-Collision 2	-	-	8821F0C01400	Yes
Front Radar Sensor	-	-	8821F0C01400	Yes
Mirror R	-	-	-	
Mirror L	-	-	-	
Immobiliser	-	-	-	
Blind Spot Monitor Master	-	-	8816F0C02101	No
Blind Spot Monitor Slave	-	-	8816F0C02102	No
Central Gateway	-	-	8911F0C01001	No

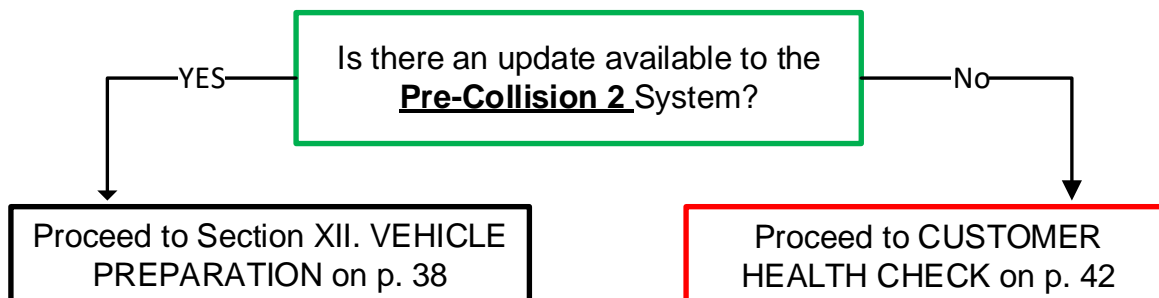

XII. VEHICLE PREPARATION

1. VEHICLE PREPARATION

a. Confirm the following conditions:

- Vehicle in the IG position (engine off).
- Transaxle in Park.
- Parking brake engaged.
- Turn off all electrical accessories (i.e. climate control, audio system, etc.)
- Headlight switch in the DRL OFF position.
- Windshield wiper switch in the OFF position.

2. CONNECT THE 12v BATTERY TO A POWER SUPPLY (GR8)

- a. Connect the GR8 or other type of a power supply (not a battery charger) to the 12v battery.
b. Select the Power Supply Mode from the Charge Menu of the GR8.



A power supply *MUST* be used during reprogramming. ECU damage will occur if the battery voltage is not properly maintained during this re-flash procedure.

Note: A power supply must be connected directly to the 12v battery terminals and NOT the remote jump posts under the hood (if equipped).

3. VERIFY TECHSTREAM SETUP

a. Verify that the Techstream meets the following conditions:

- The latest version of software is loaded.
- The Techstream battery is fully charged. If not, connect the Techstream to a 120v source.
- The DLCIII cable is in good condition.



The Techstream's battery voltage must be maintained during the update procedure. If necessary, plug the Techstream into a 120v outlet during this procedure.

Note: If the Techstream's communication with the vehicle fails during the update procedure, the ECU will be damaged.

XIII. UPDATE CALIBRATION

1. UPDATE THE CALIBRATION ID

- a. Identify the vehicles Current CID for the **Pre-Collision 2** System on the Stored Data tab.

The screenshot displays the 'Stored Data' tab for a 2018 Tundra 3UR-FE. The vehicle has 016018 miles and a production date of 10/2017. The 'Tire Pressure / Threshold Value [psi(gau)]' section shows sensor readings for five sensors. The 'Health Check Results' section indicates that live data is not displayed. The 'Campaign Status' is 'OPEN' and 'PERMANENT' is 'NO'. A table lists various systems with their current calibration IDs and update status. The 'Pre-Collision 2' system is highlighted, and its current CID, 8821F0C01400, is circled in green. A callout box labeled 'Current CID' points to this value.

System	Current CID	Calibration	Update
Tilt&Telescopic	-	-	-
SRS Airbag	-	8917F0C035	No
Navigation System	-	-	-
Pre-Collision 2	8821F0C01400	-	Yes
Front Radar Sensor	-	8821F0C01400	Yes
Mirror R	-	-	-

- b. Locate the vehicles Current CID in the chart on the following page.
- c. Select the corresponding NEW CID link to load the update.
- d. Follow the on-screen instructions to complete the Calibration Update procedure.

The CID Update Procedure is detailed in [T-SB-0134-16](#). Please reference this Bulletin for more detailed procedures and information.



Be extremely careful to select the correct **NEW CID** that corresponds to the **Current CID**.

Vehicle Specification		Millimeter Wave Radar Sensor Calibrations	
Model	Type	Current CID	New CID
TUNDRA	Non-TRD Pro	8821F0C0 <u>1100</u>	<u>8821F0C01500</u>
		8821F0C0 <u>1200</u>	
		8821F0C0 <u>1300</u>	
		8821F0C0 <u>1400</u>	
	TRD Pro	8821F0C0 <u>3100</u>	<u>8821F0C03500</u>
		8821F0C0 <u>3200</u>	
		8821F0C0 <u>3300</u>	
		8821F0C0 <u>3400</u>	
TACOMA	Non-TRD Pro	8821F040 <u>1100</u>	<u>8821F0405100</u>
		8821F040 <u>1200</u>	
		8821F040 <u>5000</u>	
	TRD Pro	8821F040 <u>2100</u>	<u>8821F0406100</u>
		8821F040 <u>2200</u>	
		8821F040 <u>6000</u>	



2. PERFORM VERIFICATION HEALTH CHECK

- Clear DTC's that may have set during the re-flash procedure.
- Re-run the Health Check to confirm that no DTC's reappear.



THIS VERIFICATION HEALTH CHECK IS NECESSARY to update the results and CID's to the National database.

3. CONFIRM CID UPDATE

a. On the Stored Data tab, confirm the following for the **Pre-Collision 2** System:

- The Update column lists “No”

The screenshot shows the 'Stored Data' tab for a 2018 Tundra 3UR-FE. The vehicle has 016018 miles and a production date of 10/2017. The 'Pre-Collision 2' system is highlighted in the table below. The 'Update' column for this system is 'No', which is circled in green. A green arrow points to this 'No' with the text 'MUST say "No"'. The table also shows other systems like Tilt&Telescopic, SRS Airbag, Navigation System, Mirror R, Mirror L, Immobiliser, Blind Spot Monitor Master, Blind Spot Monitor Slave, and Central Gateway, all with 'No' in the Update column.

System	SB	RoB	Calibration	Update
Tilt&Telescopic	-	-	-	-
SRS Airbag	-	-	8917F0C035	No
Navigation System	-	-	-	-
Pre-Collision 2	-	-	8821F0C01500	No
Front Radar Sensor	-	-	8821F0C01500	No
Mirror R	-	-	-	-
Mirror L	-	-	-	-
Immobiliser	-	-	-	-
Blind Spot Monitor Master	-	-	8816F0C02101	No
Blind Spot Monitor Slave	-	-	8816F0C02102	No
Central Gateway	-	-	8911F0C01001	No

4. COMPLETE UPDATE

a. Remove the power supply from the battery

XIV. CUSTOMER HEALTH CHECK REPORT

1. PRINT CUSTOMER HEALTH CHECK REPORT

- a. From the Stored Data tab, select the Customer Health Check Report button (TIS will launch when button is pressed).

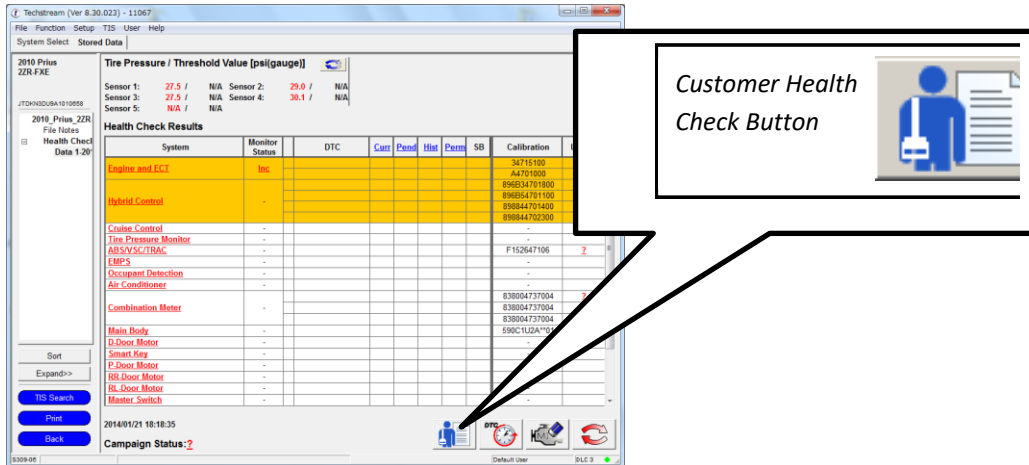

The screenshot shows the Techstream software interface. The main window displays 'Tire Pressure / Threshold Value [psi(gauge)]' with sensor data for four sensors. Below this is the 'Health Check Results' table. A callout box points to a button labeled 'Customer Health Check Button' which features an icon of a person with a clipboard.

System	Monitor Status	DTC	Curr	Perf	His	Perf	SB	Calibration
Engine and ECT	Ins						38715100	A4701000
Hybrid Control	-						89823471800	89823471800
Cruise Control	-						89823471800	89823471800
Tire Pressure Monitor	-						89823471800	89823471800
ABS/VC/TRAC	-						F152647106	2
EMPS	-							
Occupant Detection	-							
Air Conditioner	-							
Combination Meter	-						838004737004	838004737004
Main Body	-						838004737004	838004737004
D-Door Motor	-						599C1L2A-03	
Smart Key	-							
P-Door Motor	-							
RR-Door Motor	-							
RL-Door Motor	-							
Master Switch	-							

- b. Log in to TIS.
- c. Input Vehicle Mileage and Repair Order number.
- d. Check the "Performed" campaign button for campaign K0B.
- e. Select the Report button.



The screenshot shows the Diagnostic Report web interface. It features the Toyota logo and the text 'Diagnostic Report'. Below this is the 'Vehicle Information' section with fields for 'Mileage: 7787' and 'Repair Order: 7788'. A message states: 'Our systems show the following campaigns are outstanding. Have any of these campaigns been completed? (Check for SSC door label if unsure.)' with radio buttons for 'Performed' (selected) and 'Not Performed'. A 'Report' button is located at the bottom.

- f. Confirm Customer Health Check Report information is correct.



Diagnostic Report

Vehicle Information

Vehicle: 2013 Prius VIN: JTDKN3DU7D1615492 Mileage: 13672
 Repair Order: 12345

Health Check Summary

Checkpoints	Status	Comments
Powertrain	All systems OK	
Chassis	All systems OK	
Electrical	All systems OK	
Network Systems	All systems OK	
Service Campaigns	No Action Required	JOV Performed

Performed: 02/20/14, 4:36 PM (PST)

Technician Signature

Quality Inspector Signature

- g. Print Customer Health Check Report from TIS.
- h. Sign and provide to the customer.

2. ATTACH THE AUTHORIZED VEHICLE MODIFICATION LABEL

- a. Fill out the label.
- b. Affix the label to the under-side of the hood.

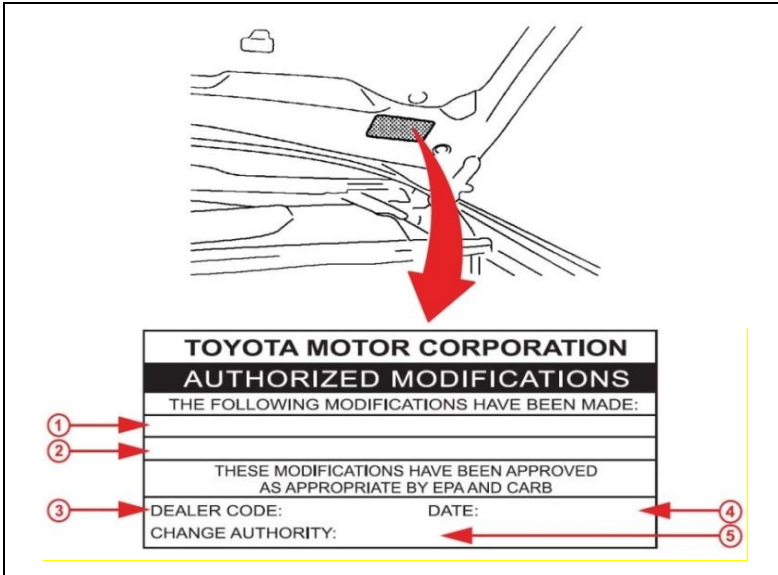

1	Pre Collision
2	(Calibration ID's)
3	(Dealer Code)
4	(Date Completed)
5	Safety Recall K0B

Calibration ID's listed for the Pre Collision 2 System after completing the final Health Check. The CID's will vary for car to car.

◀ VERIFY REPAIR QUALITY ▶

- Confirm that the EPT-Sealer is properly applied.
- Confirm that the EPT-Sealer has good adhesion to the MWRS.
- Confirm that the radiator grill is reinstalled correctly.
- Confirm that the system has been properly calibrated, if necessary.

If you have any questions regarding this update, please contact your regional representative.

XV. APPENDIX

A. PARTS DISPOSAL

As required by Federal Regulations, please make sure all recalled parts (original parts) removed from the vehicle are disposed of in a manner in which they will not be reused, ***unless requested for parts recovery return.***

B. CAMPAIGN DESIGNATION DECORDER

