



TECHNICAL BULLETIN

29 MAY 2019

© Jaguar Land Rover North America, LLC

NOTE: The information in Technical Bulletins is intended for use by trained, professional Technicians with the knowledge, tools, and equipment required to do the job properly and safely. It informs these Technicians of conditions that may occur on some vehicles, or provides information that could assist in proper vehicle service. The procedures should not be performed by 'do-it-yourselfers'. If you are not a Retailer, do not assume that a condition described affects your vehicle. Contact an authorized Land Rover service facility to determine whether this bulletin applies to a specific vehicle.

SECTION:

419-02

SUBJECT/CONCERN:

'Smart key not found' Message Displayed and Poor Smart key Operation

AFFECTED VEHICLE RANGE:

MODEL:	MODEL YEAR:	VIN:	ASSEMBLY PLANT:
Discovery (LR)	2018-2019	047448-096625	Solihull
Range Rover Sport (LW)	2018	181320-199999	Solihull
Range Rover Sport (LW)	2018	690430-599999	Solihull
Range Rover Sport (LW)	2018-2019	800002-862860	Solihull
Range Rover Sport (LW)	2018-2019	400000-427053	Solihull
Range Rover (LG)	2018	380217-399999	Solihull
Range Rover (LG)	2018-2019	500023-558542	Solihull

MARKETS:

NORTH AMERICA

CONDITION SUMMARY:

SITUATION:

A 'Smart key not found' message may be displayed on the Instrument Cluster and poor Smart key operation may be evident.

CAUSE:

This may be caused by a wiring harness issue or faulty Radio Frequency (RF) antenna.

ACTION:



Should a customer express this concern, follow the procedure(s) below.

PARTS:

PART NUMBER	DESCRIPTION	QUANTITY
DISCOVERY (L462)		
LR112609	RF Antenna with Coaxial Cable	1
BNP3996	Adhesive pad(s)	12
LR091317	Headliner trim clip(s)	1
LR034879	B-pillar trim clip(s)	4
LR036129	C/D-pillar trim clip(s)	16
LR090727	C/D-pillar trim clip(s)	6
LR082272	C/D-pillar trim clip(s)	4
RANGE ROVER SPORT (L494)		
LR112609	RF Antenna with Coaxial Cable	1
BNP3996	Adhesive pad(s)	12
LR043263	Headliner trim clip(s)	1

PART NUMBER	DESCRIPTION	QUANTITY
LR034879	B-pillar trim clip(s)	4
LR006101	C-pillar trim clip(s)	4
LR036129	C-pillar trim clip(s)	4
LR034879	C-pillar trim clip(s)	4
LR038293	D-pillar trim clip(s)	8
RANGE ROVER (L405)		
LR112609	Radio Frequency (RF) Antenna with Coaxial Cable	1
BNP3996	Adhesive pad(s)	16
LR043263	Headliner trim clip(s)	1

TOOLS:

 <p>E192494</p>	<p>Jaguar Land Rover-approved Midtronics battery power supply</p>	 <p>E208514</p>	<p>Jaguar Land Rover-approved diagnostic equipment with latest PATHFINDER software</p>
--	---	---	--

WARRANTY:

NOTES:

- Repair procedures are under constant review, and therefore times are subject to change; those quoted here must be taken as guidance only. Use TOPIx to obtain the latest repair time.
- The JLR claims submission system requires the use of causal part numbers. Labor only claims must show the causal part number with a quantity of zero.

DESCRIPTION	SRO	TIME (HOURS)	CONDITION CODE	CAUSAL PART
-------------	-----	--------------	----------------	-------------

DESCRIPTION	SRO	TIME (HOURS)	CONDITION CODE	CAUSAL PART
RFA coaxial cable -- Discovery	86.54.39	2.1	07	LR112609
RFA coaxial cable -- Range Rover Sport	86.54.39	1.8	07	LR112609
RFA coaxial cable -- Range Rover	86.54.39	2.00	07	LR112609

 **NOTE:**

Normal Warranty procedures apply.

DIAGNOSTIC PROCEDURE:

 **CAUTIONS:**

- A Jaguar Land Rover-approved Midtronics battery power supply must be connected to the vehicle startup battery.
- All ignition ON/OFF requests **MUST** be performed; failure to do these steps may cause damage to vehicle control modules.

1 Connect the Jaguar Land Rover-approved Midtronics battery power supply to the vehicle startup battery.

2  **NOTE:**

The Jaguar Land Rover-approved diagnostic equipment must be loaded with PATHFINDER version 233 (or later).

Connect the Jaguar Land Rover-approved diagnostic equipment to the vehicle and begin a new session.

3  **NOTE:**

The Jaguar Land Rover-approved diagnostic equipment will read the correct Vehicle Identification Number (VIN) for the current vehicle and automatically take the vehicle

out of Transit mode (if required).

Follow all on-screen instructions.

4 Select **ECU Diagnostics**.

5 Select **All DTCs**.

- If any DTC (Diagnostic Trouble Code) is stored in the Remote Function Actuator (RFA), do not continue with this Technical Bulletin; investigate and repair (see TOPlx Workshop Manual section 419-01: Anti-Theft -- Passive -- Diagnosis and Testing -- Anti-Theft -- Passive). To be performed as a separate claim.
- If there are no DTCs stored in the RFA, continue to the Workshop Procedure below.

6 Exit the current session.

- 1** If required, reset the vehicle to **Transit mode**.
- 2** Select the **Exit** icon.

7 Disconnect the diagnostic equipment and battery power supply from the vehicle.

SERVICE INFORMATION:

NOTE:

Some components have been removed for clarity.

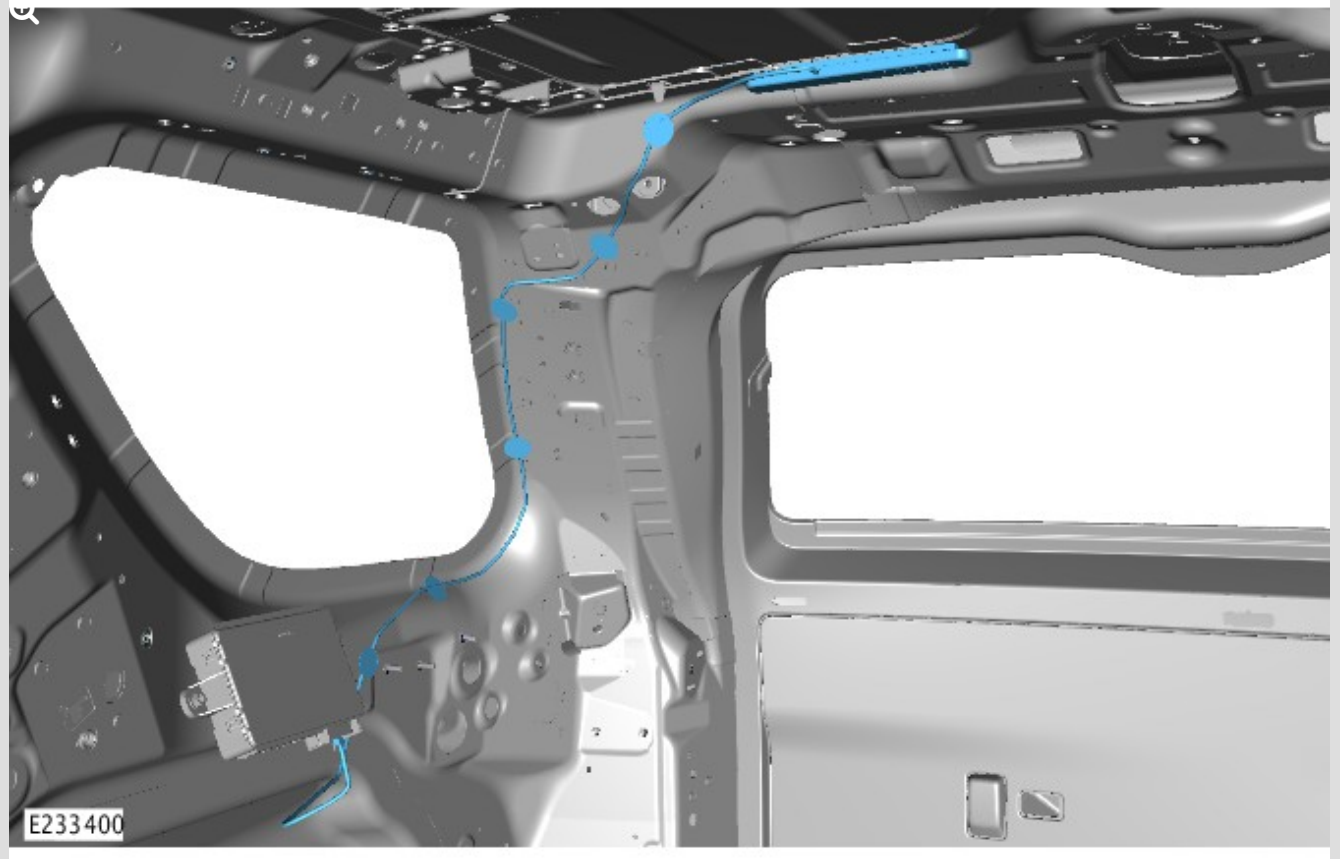

Discovery: Coaxial cable wiring harness route.

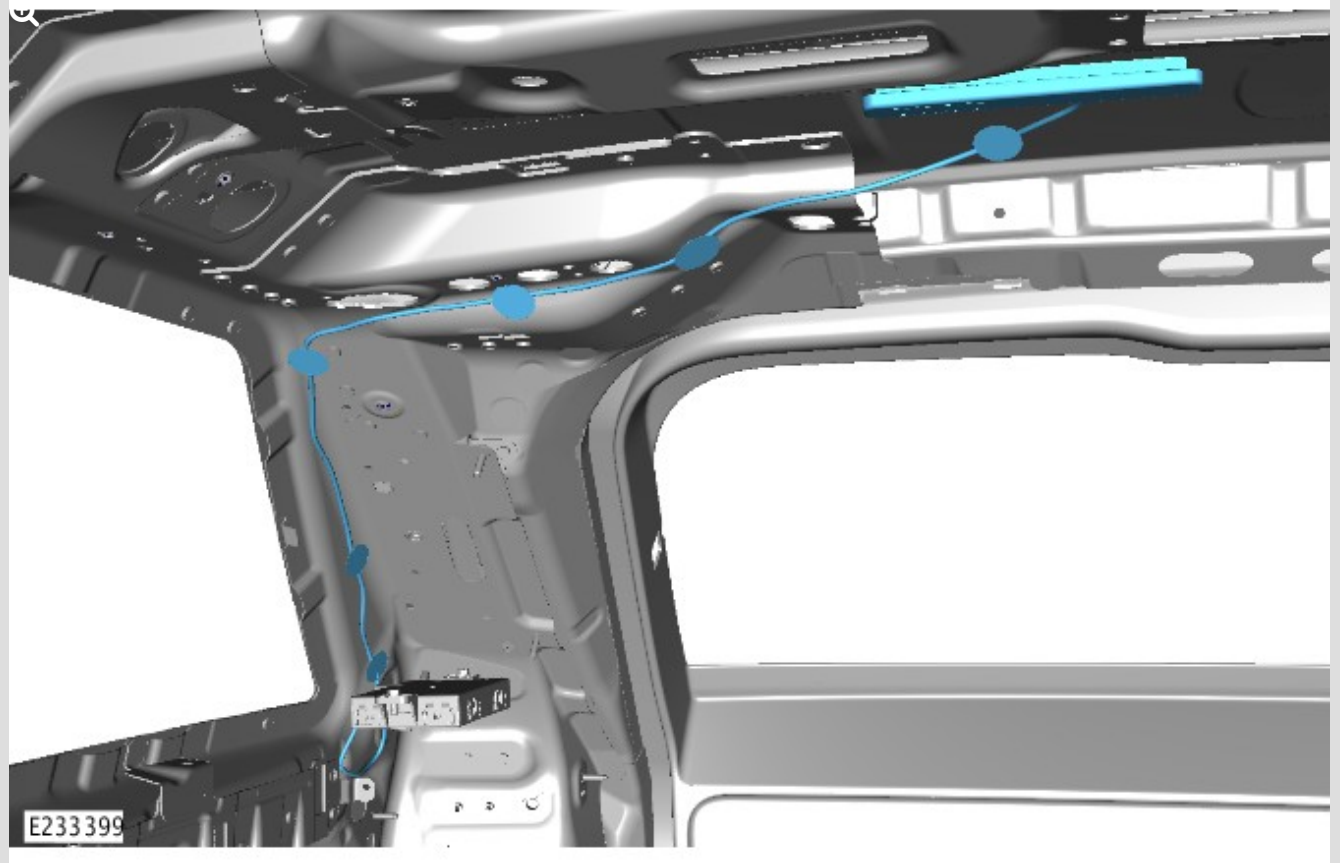

Range Rover Sport: Coaxial cable wiring harness route.

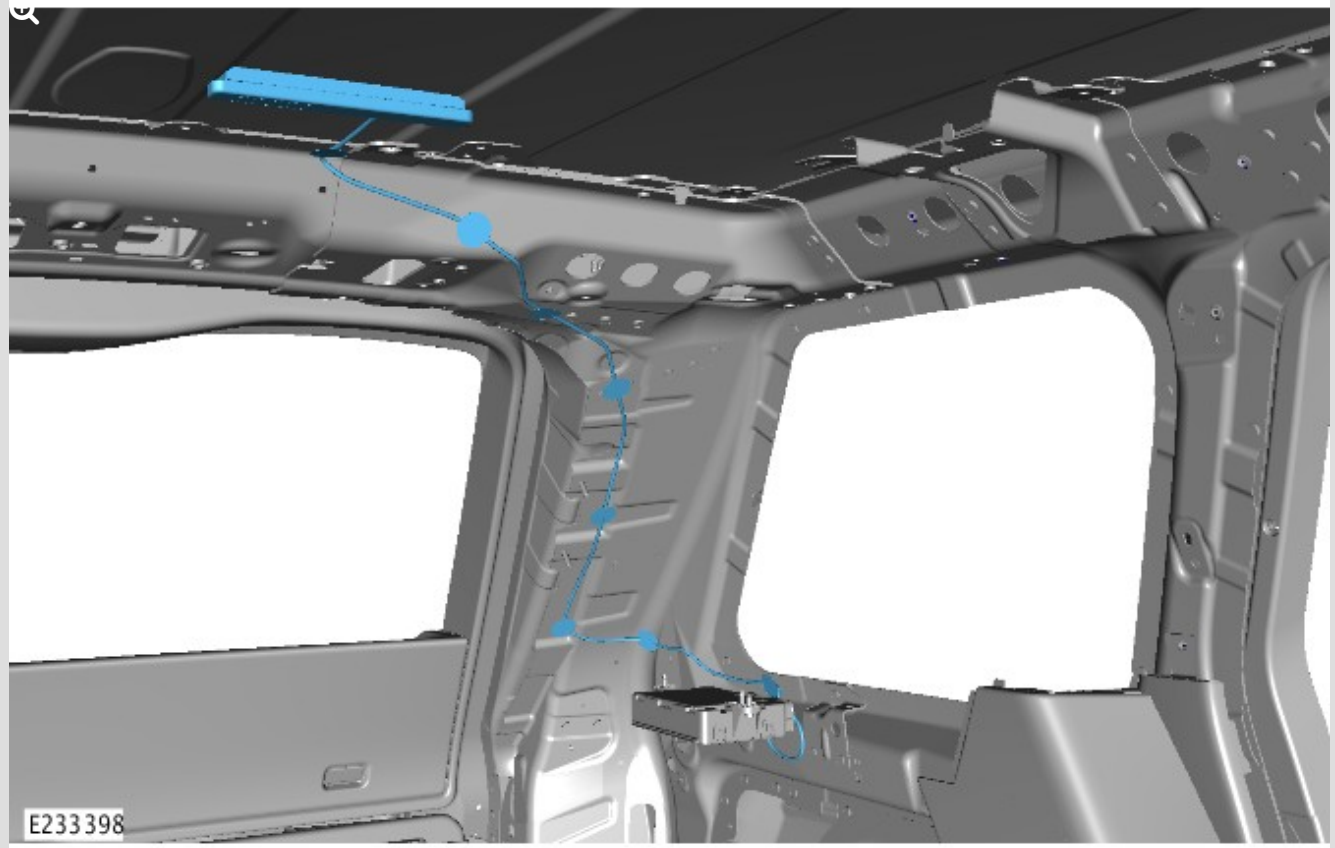

Range Rover: Coaxial cable wiring harness route.

WORKSHOP PROCEDURE 'A' - DISCOVERY, RANGE ROVER SPORT:

⚠ NOTES:

- If the keyless entry functionality is correct, do not continue with this Technical Bulletin. Continue diagnosis using the Jaguar Land Rover-approved diagnostic equipment and the TOPIx Workshop Manual.
- Check the voltage of the Smart key battery and replace if required.
- The coaxial cable and Radio Frequency (RF) antenna cannot be replaced separately.

⚠ WARNING:

Avoid damage to the headliner.

Lower the headliner for access.

- **DISCOVERY:** (see TOPIx Workshop Manual section 501-05: Interior Trim and Ornamentation -- Removal and Installation -- Headliner -- Removal Steps 1-22).
- **RANGE ROVER SPORT:** (see TOPIx Workshop Manual section 501-05: Interior Trim and Ornamentation -- Removal and Installation -- Headliner Remove for Access and Refit).

2 Remove the loadspace right trim panel (see TOPIx Workshop Manual section 501-05: Interior Trim and Ornamentation -- Removal and Installation -- Right Loadspace Trim Panel).

3 Remove the luggage compartment right upper trim panel (see TOPIx Workshop Manual section 501-05: Interior Trim and Ornamentation -- Removal and Installation -- Luggage Compartment Upper Trim Panel).

4 Verify that the coaxial cable from the Radio Frequency (RF) antenna to the Remote Function Actuator (RFA) is correctly routed, secured in position, and is not trapped. Inspect the condition of the connectors and the connector pins between the RF antenna and RFA for damage. Make sure that connections are secure. Refer to the Service Information section above for wiring harness routes and locations.

- If the coaxial cable is damaged, incorrectly routed, or trapped, go to Step 7.
- If the coaxial cable and/or connectors and connector pins are damaged, go to Step 6.
- If the coaxial cable is incorrectly routed or trapped, but no damage has occurred, go to Step 5.

5  **NOTE:**

Re-use the adhesive pads where possible.

Route the coaxial cable as shown in the Service Information section above and secure in place with adhesive pads to make sure the cable will remain in its position.

1 When all tasks are finished, go to Step 7

 **NOTE:**

The Radio Frequency (RF) antenna must be located correctly in place by applying gentle pressure only to both sides -- not in the middle -- of the antenna body.

Renew the RF antenna and Coaxial cable.

- 1 Route the coaxial cable as shown in the Service Information section above; secure in place with adhesive pads to make sure the cable will remain in position
- 2 When all tasks are finished, go to Step 7

Test the Smart key functions.

- If the customer concern is not evident (Smart key does function correctly), go to Step 8.
- If the customer concern is evident (Smart key does not function correctly), diagnosis using the Jaguar Land Rover-approved diagnostic equipment and TOPIx Workshop Manual.

Install the luggage compartment right upper trim panel (see TOPIx Workshop Manual section 501-05: Interior Trim and Ornamentation -- Removal and Installation -- Luggage Compartment Upper Trim Panel).

Install the loadspace right trim panel (see TOPIx Workshop Manual section 501-05: Interior Trim and Ornamentation -- Removal and Installation -- Right Loadspace Trim Panel).

 **WARNING:**

Avoid damage to the headliner.

Install the headliner.

- **DISCOVERY:** (see TOPIx Workshop Manual section 501-05: Interior Trim and Ornamentation -- Removal and Installation -- Headliner -- Install Steps 8-11 only).

- **RANGE ROVER SPORT:** (see TOPIx Workshop Manual section 501-05: Interior Trim and Ornamentation -- Removal and Installation -- Headliner Remove for Access and Refit).

WORKSHOP PROCEDURE 'B' - RANGE ROVER:

NOTES:

- If the keyless entry functionality is correct, do not continue with this Technical Bulletin. Continue diagnosis using the Jaguar Land Rover-approved diagnostic equipment and the TOPIx Workshop Manual.
- Check the voltage of the Smart key battery and replace if required.
- The coaxial cable and Radio Frequency (RF) antenna cannot be replaced separately.

1

WARNING:

Avoid damage to the headliner.

Lower the headliner for access (see TOPIx Workshop Manual section 501-05: Interior Trim and Ornamentation -- Removal and Installation -- Headliner Remove for Access and Refit).

2

Remove the loadspace left trim panel (see TOPIx Workshop Manual section 501-05: Interior Trim and Ornamentation -- Removal and Installation -- Left Loadspace Trim Panel).

3

Remove the luggage compartment left upper trim panel (see TOPIx Workshop Manual section 501-05: Interior Trim and Ornamentation -- Removal and Installation -- Luggage Compartment Upper Trim Panel).

4

Verify that the coaxial cable from the Radio Frequency (RF) antenna to the Remote Function Actuator (RFA) is correctly routed, secured in position, and is not trapped. Inspect the condition of the connectors and the connector pins between the RF antenna and RFA for

damage. Make sure that connections are secure. Refer to the Service Information section above for wiring harness routes and locations.

- If the coaxial cable is damaged, incorrectly routed, or trapped, go to Step 7.
- If the coaxial cable and/or connectors and connector pins are damaged, go to Step 6.
- If the coaxial cable is incorrectly routed or trapped, but no damage has occurred, go to Step 5.

5

 **NOTE:**

Re-use the adhesive pads where possible.

Route the coaxial cable as shown in the Service Information section above and secure in place with adhesive pads to make sure the cable will remain in its position.

- 1 When all tasks are finished, go to Step 7

6

 **NOTE:**

The Radio Frequency (RF) antenna must be located correctly in place by applying gentle pressure only to both sides -- not in the middle -- of the antenna body.

Renew the RF antenna and Coaxial cable.

- 1 Route the coaxial cable as shown in the Service Information section above; secure in place with adhesive pads to make sure the cable will remain in position
- 2 When all tasks are finished, go to Step 7

7

Test the Smart key functions.

- If the customer concern is not evident (Smart key does function correctly), go to Step 8.
- If the customer concern is evident (Smart key does not function correctly), diagnosis using the Jaguar Land Rover-approved diagnostic equipment and TOPIx Workshop Manual.

8 Install the luggage compartment left upper trim panel (see TOPIx Workshop Manual section 501-05: Interior Trim and Ornamentation -- Removal and Installation -- Luggage Compartment Upper Trim Panel).

9 Install the loadspace left trim panel (see TOPIx Workshop Manual section 501-05: Interior Trim and Ornamentation -- Removal and Installation -- Left Loadspace Trim Panel).

10



WARNING:

Avoid damage to the headliner.

Install the headliner (see TOPIx Workshop Manual section 501-05: Interior Trim and Ornamentation -- Removal and Installation -- Headliner Remove for Access and Refit).