

Rear Engine Cover Not Installed (TI 60/19)

Vehicle Type: **Panamera GTS (971)/Panamera GTS Sport Turismo (971)
Panamera Turbo (971)/Panamera Turbo Executive (971)/
Panamera Turbo Sport Turismo (971)
Panamera Turbo S E-Hybrid (971)/Panamera Turbo S E-Hybrid Executive (971)/
Panamera Turbo S E-Hybrid Executive (971)**

Model Year: **As of 2019 up to 2020**

Equipment: 4.0 I V8 engine

Subject: **Rear engine design cover**

Information: **Since week 18/2019, the rear section of the engine design cover is no longer installed during production.**

While performing the sales check, there may be vehicles with and without the rear section of the engine design cover during this transition period.

On vehicles without the rear engine design cover, this cover does not have to be retrofitted during the sales check and **must not be invoiced as a missing part using a warranty claim.**

Date of Introduction: First vehicle without engine design cover: WPOAG2A70KL139960.

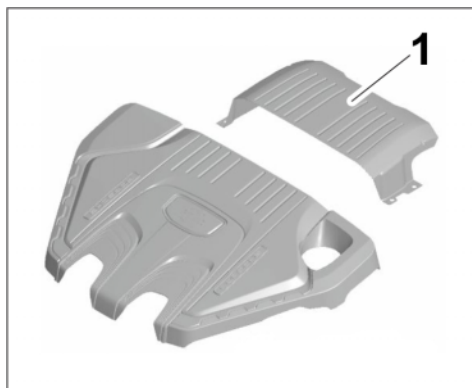

Engine design cover

- 1** – Engine design cover, **rear** (no longer installed)

Important Notice: Technical Bulletins issued by Porsche Cars North America, Inc. are intended only for use by professional automotive technicians who have attended Porsche service training courses. They are written to inform those technicians of conditions that may occur on some Porsche vehicles, or to provide information that could assist in the proper servicing of a vehicle. Porsche special tools may be necessary in order to perform certain operations identified in these bulletins. Use of tools and procedures other than those Porsche recommends in these bulletins may be detrimental to the safe operation of your vehicle, and may endanger the people working on it. Properly trained Porsche technicians have the equipment, tools, safety instructions, and know-how to do the job properly and safely. Part numbers listed in these bulletins are for reference only. The work procedures updated electronically in the Porsche PIWIS diagnostic and testing device take precedence and, in the event of a discrepancy, the work procedures in the PIWIS Tester are the ones that must be followed.

© 2019 Porsche Cars North America, Inc.