

May 31, 2019

Version 2

Warranty Extension: Steering Feels Heavy, EPS Indicator Blinks with No DTCs or Comes On Steady with DTC 32-09, 32-08, or 61-04

Supersedes 19-021, dated April 19, 2019; See REVISION SUMMARY

AFFECTED VEHICLES

Year	Model	Trim	VIN Range
2012-14	TL	ALL	Check the iN VIN status for eligibility.
2011-14	TSX	L4	Check the iN VIN status for eligibility.
2011-14	TSX Sport Wagon	ALL	Check the iN VIN status for eligibility.

REVISION SUMMARY

This bulletin was revised extensively because the TSX (L4) and TSX Sport Wagon were added.

BACKGROUND

American Honda is extending the warranty on the EPS (electric power steering) control unit to 15 years from the original date of purchase with unlimited miles.

This warranty covers vehicles where the steering feels heavier than normal, or is hard to turn, particularly when the vehicle is not moving, and either the EPS indicator blinks with no DTCs, or the EPS indicator comes on steady with DTC 32-09 (motor current correlation), DTC 32-08 (EPS control unit internal circuit [current sensor]), or DTC 61-04 (motor harness malfunction).

The warranty extension does not apply to any vehicle that has ever been declared a total loss or sold for salvage by a financial institution or insurer, or has a branded or similar title under any state's law.

CLIENT NOTIFICATION

Owners of affected vehicles will be sent a notification of this campaign.

Do an iN VIN status inquiry to make sure the vehicle is shown as eligible.

CORRECTIVE ACTION

Do the diagnosis and, if directed by the results, replace the EPS control unit.

CLIENT INFORMATION: The information in this bulletin is intended for use only by skilled technicians who have the proper tools, equipment, and training to correctly and safely maintain your vehicle. These procedures should not be attempted by "do-it-yourselfers," and you should not assume this bulletin applies to your vehicle, or that your vehicle has the condition described. To determine whether this information applies, contact an authorized Acura automobile dealer.

DIAGNOSIS

1. Connect the i-HDS, and check for the following DTCs:
 - 32-09 (motor current correlation)
 - 32-08 (EPS control unit internal circuit [current sensor])
 - 61-04 (motor harness malfunction)
 - If any of the listed DTCs are set, write down the DTC on the RO, and go to the applicable vehicle's REPAIR PROCEDURE.
 - If none of the listed DTCs are set, go to step 2.
2. Check if there are any other DTCs set.
 - If there are other EPS DTCs set, this bulletin does not apply. Continue with normal system troubleshooting.
 - If there are no other EPS DTCs set, go to step 3.
3. Check if the EPS indicator is blinking.



- If the EPS indicator is blinking, go to the applicable vehicle's REPAIR PROCEDURE.
- If the EPS indicator is not blinking, this bulletin does not apply. Continue with normal system troubleshooting.

PARTS INFORMATION

Part Name	Part Number	Quantity
2012-14 TL (6AT) EPS Control Unit	39980-TK4-A01	1
2012-14 TL SH-AWD (6AT) EPS Control Unit	39980-TK5-A01	1
2012-14 TL SH-AWD (6MT) EPS Control Unit	39980-TK5-A11	1
2011-14 TSX (L4) EPS Control Unit	39980-TL2-A05	1
2011-14 TSX Sport Wagon EPS Control Unit	39980-TL7-A01	1

REQUIRED TOOLS

Part Name	Tool Number	Quantity
KTC Trim Tool Set	SOJATP2014	1

WARRANTY CLAIM INFORMATION

NOTE

Make sure you enter any set DTCs in the DTC field of the warranty claim.

Operation Number	Description	Flat Rate Time	Defect Code	Symptom Code	Template ID	Failed Part Number
5131M0	2012-14 TL (AT): Replace the EPS control unit.	0.8 hr	6E100	G4I00	B19021A	39980-TK4-A01
5131M0	2012-14 TL with SH-AWD (6AT): Replace the EPS control unit.	0.8 hr	6E100	G4I00	B19021B	39980-TK4-A01
5131M0	2012-14 TL with SH-AWD (6MT): Replace the EPS control unit.	0.8 hr	6E100	G4I00	B19021C	39980-TK4-A01
5131M0	2011-14 TSX (L4): Replace the EPS control unit.	0.6 hr	6E100	G4I00	B19021D	39980-TL2-A05
5131M0	2011-14 TSX Sport Wagon: Replace the EPS control unit.	0.6 hr	6E100	G4I00	B19021F	39980-TL2-A05

Skill Level: Repair Technician

REPAIR PROCEDURE

TL EPS Control Unit Replacement

NOTE

Some systems store data in memory (including seat position, mirror position, etc.) that is lost when the battery is disconnected.

1. Make sure you have the anti-theft code for the audio system or the navigation unit.
2. Make sure the ignition is turned to OFF, then disconnect and isolate the negative cable from the 12 volt battery.
3. Remove the front passenger's dashboard undercover.

NOTES

- Make sure not to scratch the dashboard or the related parts.
 - Use the appropriate trim tool to avoid damaging components.
 - Wear gloves to protect your hands.
- 3.1. Gently pull down the rear edge of the front passenger's dashboard undercover to detach the clips.

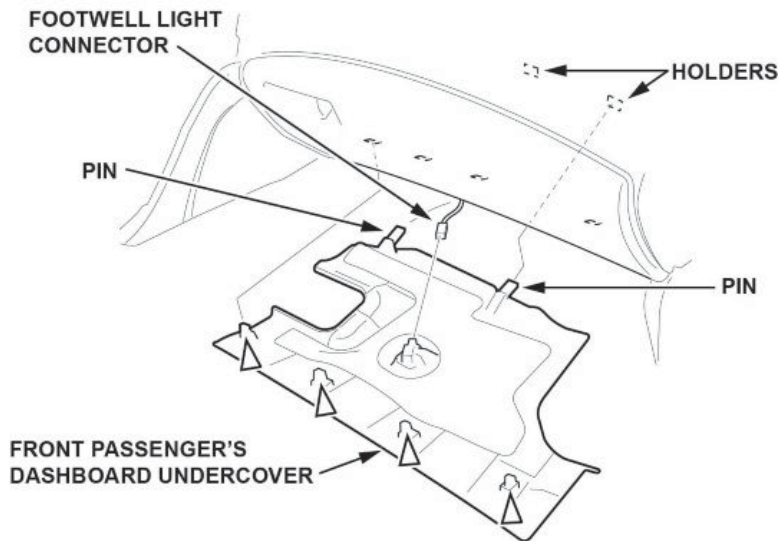

- 3.2. Disconnect the front passenger's footwell light connector.
- 3.3. Pull out the undercover to release the pins from the holders.

4. Release the hooks from the passenger's kick panel and the passenger's B-pillar lower trim, pull up the passenger's front door sill trim by hand to detach the clips, then remove the trim.

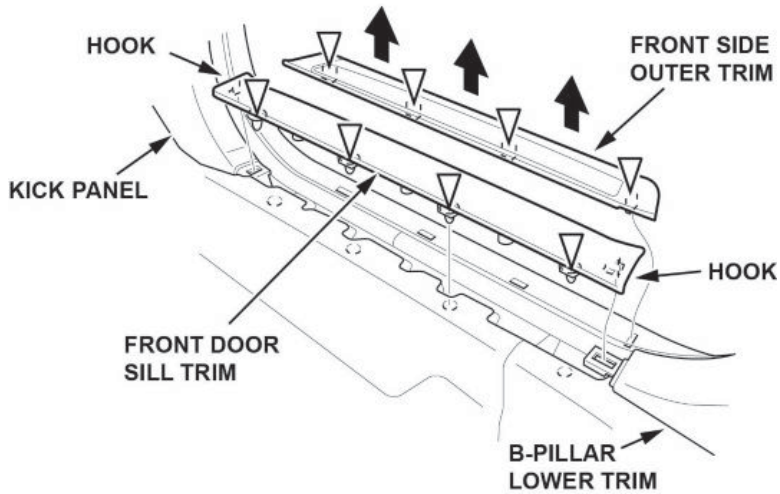

5. If necessary, pull up the passenger's front side outer trim to detach the clips, then remove the trim.
6. Remove the passenger's kick panel.
 - 6.1. Pull out the front door opening seal from the kick panel hooks as needed.

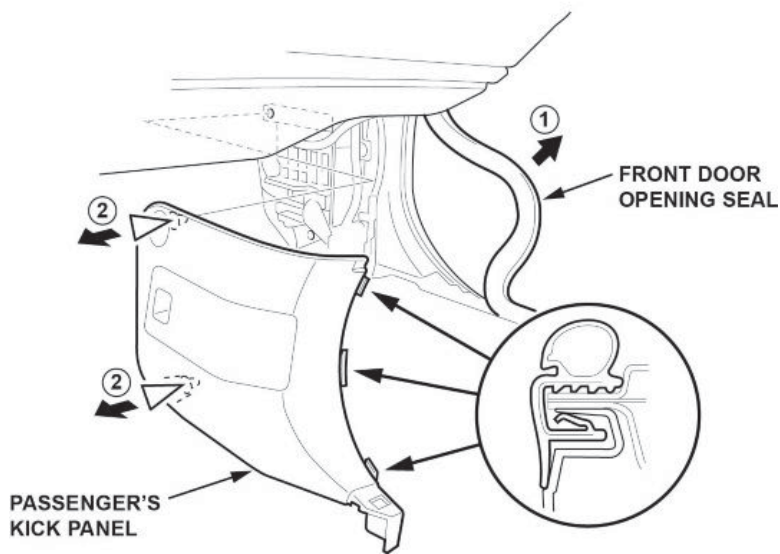

- 6.2. Pull back the kick panel by hand to detach the clips.

7. Disconnect the connectors from the passenger's under-dash fuse/relay box.

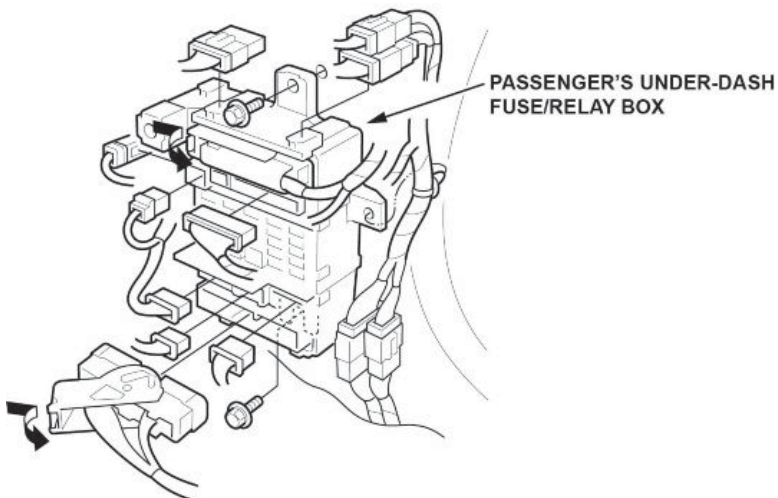

8. Loosen the mounting bolt from the lower side of the passenger's under-dash fuse/relay box.

9. Remove the mounting bolt from the upper side of passenger's under-dash fuse/relay box, and remove the passenger's under-dash fuse/relay box.

10. Disconnect the EPS control unit connectors.

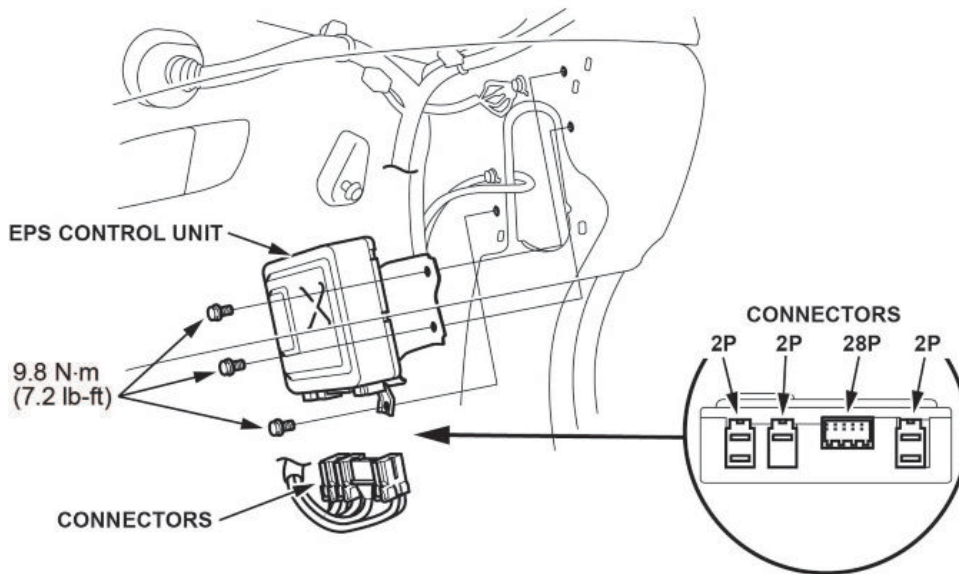

11. Remove the three bolts from the EPS control unit, then remove the unit.

12. Install the new EPS control unit, torque the three bolts to **9.8 N·m (7.2 lb-ft)**, then connect the connectors.

13. Install the passenger's under-dash fuse/relay box, and connect the connectors.

14. Connect the negative cable to the 12 volt battery.

15. Enter the audio and/or navigation system anti-theft code.

16. With the ignition turned to OFF, connect the i-HDS to the DLC.

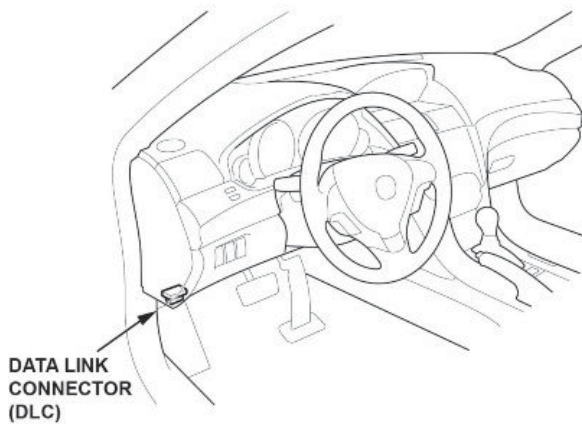

17. Turn the ignition to ON.

18. From the **EPS MENU**, select **ADJUSTMENT**, then **TORQUE SENSOR LEARN**, and follow the screen prompts.

NOTE

The torque sensor is temperature sensitive. When memorizing the torque sensor neutral position, the ambient temperature must be above **68 °F (20 °C)**. **If the torque sensor learn is not done correctly, the steering effort will not be equal in both directions.**

19. Turn the ignition switch to LOCK(0).

20. Install all the remaining parts in the reverse order of removal.

TSX and TSX Sport Wagon EPS Control Unit Replacement

NOTE

Some systems store data in memory (including seat position, mirror position, etc.) that is lost when the battery is disconnected.

1. Make sure you have the anti-theft code for the audio system or the navigation unit.
2. Make sure the ignition is turned to OFF, then disconnect and isolate the negative cable from the 12 volt battery.
3. Remove the front passenger's dashboard side panel lid.

NOTES

- Make sure not to scratch the dashboard or the related parts.
 - Use the appropriate trim tool to avoid damaging components.
 - Wear gloves to protect your hands.
- 3.1. Open the front passenger's door.
 - 3.2. Open the glove box.
 - 3.3. Gently pull the rear edge of the lid outward by hand to release the hooks.

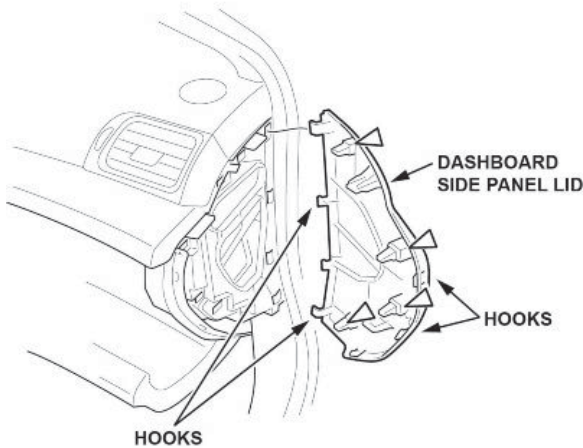

- 3.4. Continue pulling the lid outward to release the clips and hooks.
 - 3.5. Release the hooks at the front edge of the lid.
4. Remove the passenger's dashboard trim by detaching the clips.

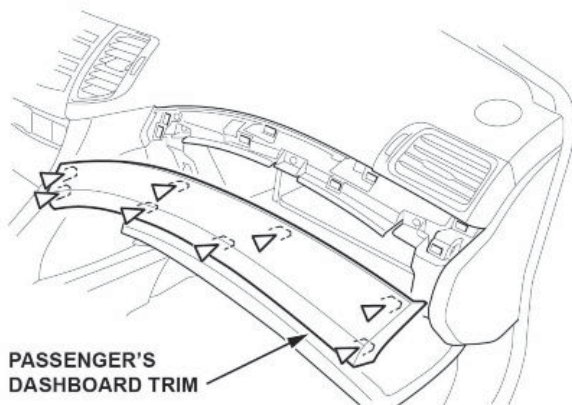

5. Remove the glove box.

5.1. Make sure the glove box is closed, and remove the bolts and screws.

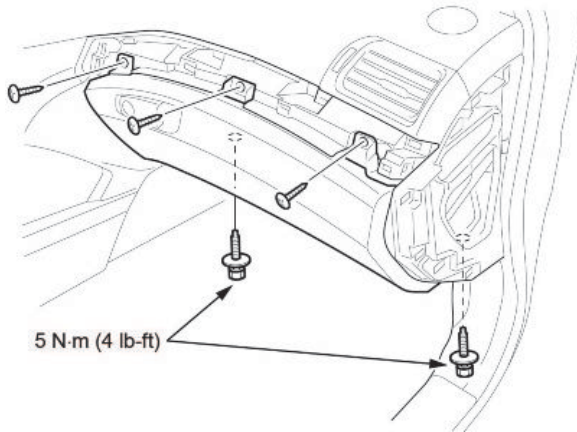

5.2. Pull the glove box by hand to detach the clips.

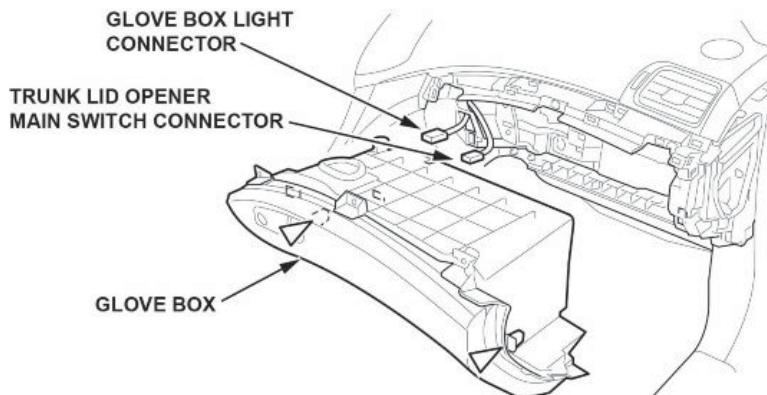

5.3. While holding the glove box, disconnect the glove box light connector.

NOTE

TSX only (not TSX Sport Wagon) - Disconnect the trunk lid opener main switch connector.

6. Remove the front passenger's dashboard undercover.

6.1. Gently pull out the rear edge to detach the clips.

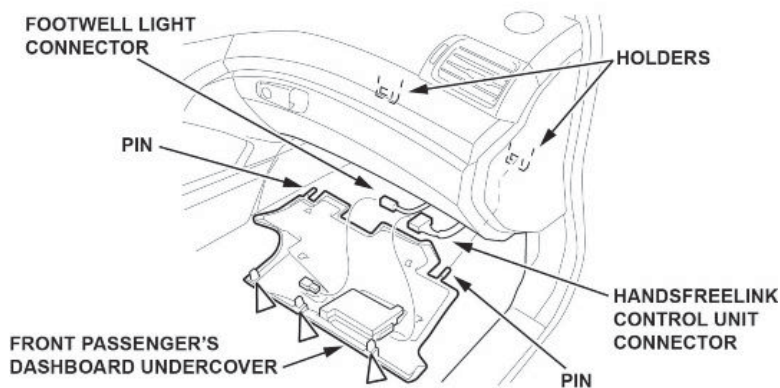

6.2. Pull the undercover away to release the pins from the holders.

6.3. Disconnect the footwell light connector and the HandsFreeLink control unit connector.

7. Remove the front passenger's door sill trim.

7.1. Detach the hooks and tabs from the front passenger's kick panel and the B-pillar lower trim.

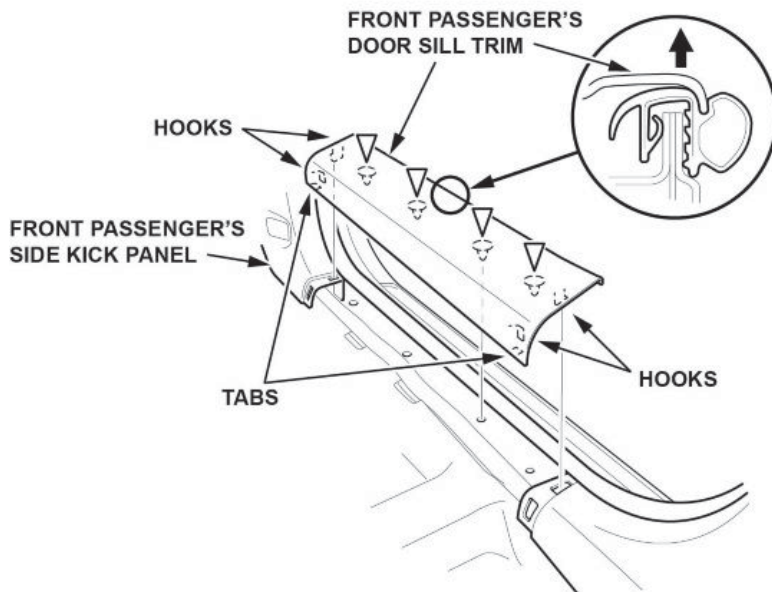

7.2. Remove the door sill trim by pulling it up to detach the clips.

8. Remove the front passenger's kick panel.

8.1. Pull the front door opening seal away as needed to access the kick panel.

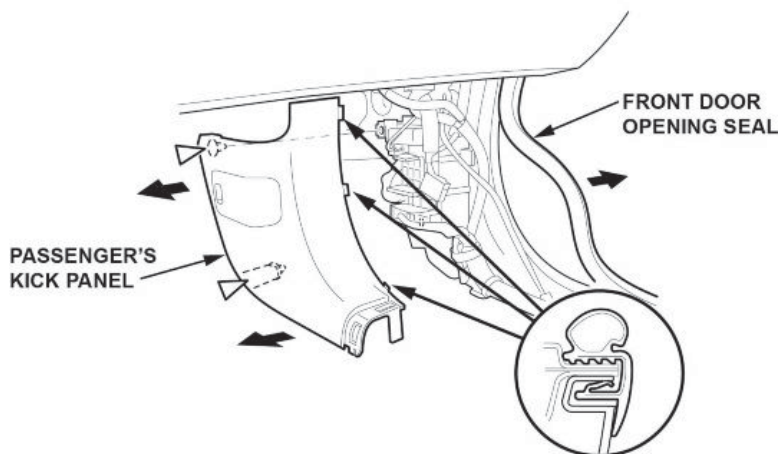

8.2. Pull back the passenger's kick panel by hand to detach the clips.

8.3. Remove the kick panel.

9. Disconnect the connectors from the passenger's under-dash fuse/relay box.

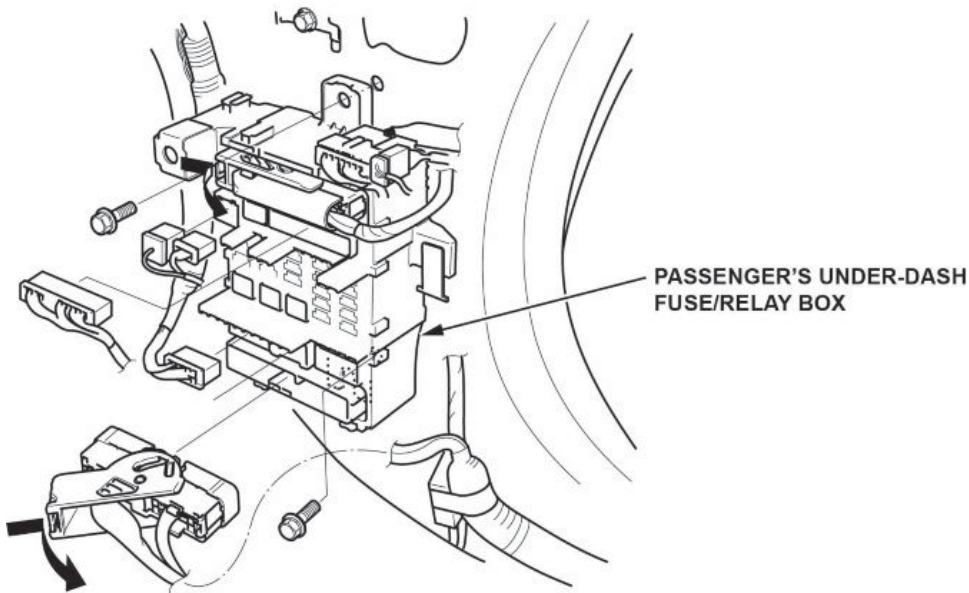

10. Loosen the mounting bolt from the lower side of the passenger's under-dash fuse/relay box.
11. Remove the mounting bolt from the upper side of passenger's under-dash fuse/relay box, and remove the passenger's under-dash fuse/relay box.
12. Disconnect the EPS control unit connectors.

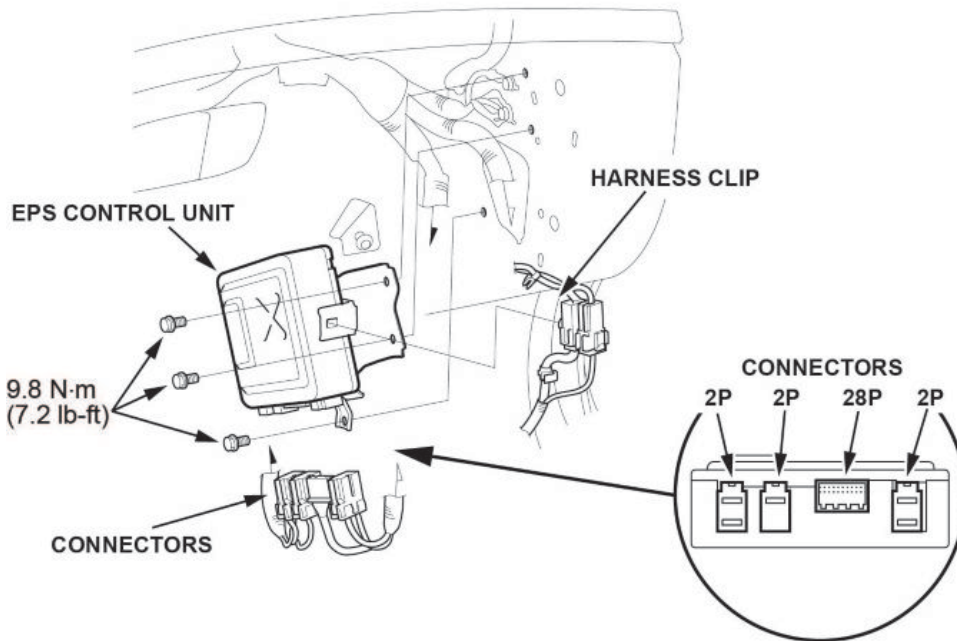

13. Remove the three bolts from the EPS control unit, then remove the unit.
14. Install the new EPS control unit, torque the three bolts to **9.8 N·m (7.2 lb-ft)**, then connect the connectors.
15. Install the passenger's under-dash fuse/relay box, and connect the connectors.
16. Connect the negative cable to the 12 volt battery.
17. Enter the audio and/or navigation system anti-theft code.

18. With the ignition turned to OFF, connect the i-HDS to the DLC.

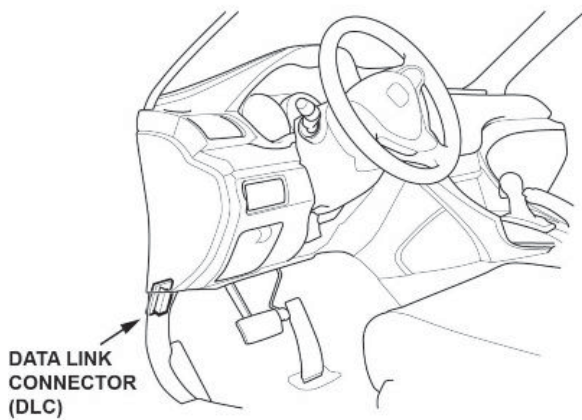

19. Turn the ignition to ON.

20. From the **EPS MENU**, select **ADJUSTMENT**, then **TORQUE SENSOR LEARN**, and follow the screen prompts.

NOTE

The torque sensor is temperature sensitive. When memorizing the torque sensor neutral position, the ambient temperature must be above **68 °F (20 °C)**. **If the torque sensor learn is not done correctly, the steering effort will not be equal in both directions.**

21. Turn the ignition switch to LOCK(0).

22. Install all the remaining parts in the reverse order of removal.

END