

March 2019  
SF561A-F

## Subject: Cummins Green House Gas 2017 Engine Aftertreatment System Retrofit

**Models Affected: Specific Freightliner 108SD, Business Class M2, and Cascadia model vehicles and Western Star 4700 and 4900 model vehicles, manufactured August 1, 2016, through August 22, 2016.**

### General Information

Daimler Trucks North America, LLC (DTNA), on behalf of its Freightliner Trucks Division and wholly-owned subsidiary, Western Star Truck Sales, Inc., is initiating Field Service Campaign SF561A-F to modify the vehicles mentioned above.

Certain pre-series vehicles have an early-design after treatment device (ATD) and/or ATD brackets.

Vehicles will have the ATD and/or ATD brackets replaced. **IMPORTANT: Advance arrangements are required for this field service campaign. All parts should be at your location before the vehicle arrives.**

In addition to SF561, Cummins advises that their pre-series engine retrofit be done at the same time. **See instructions under Replacement Parts for how to order Cummins parts, work instructions, and claim instructions.**

There are approximately 17 vehicles involved.

#### Additional Repairs

Dealers must complete all outstanding field service campaigns prior to the sale or delivery of a vehicle. A Dealer will be liable for any progressive damage that results from its failure to complete campaigns before sale or delivery of a vehicle.

Owners may be liable for any progressive damage that results from failure to complete campaigns within a reasonable time after receiving notification.

Please contact Warranty Campaigns for consideration of additional charges prior to performing the repair.

### Work Instructions

Please refer to the attached work instructions. Prior to performing the campaign, check the vehicle for a completion sticker (Form WAR261).

### Replacement Parts

Replacement parts for SF561 are now available and can be obtained by ordering the part(s) listed in **Table 1** on the next page. For SF561 some parts must be ordered from your Cummins distributor, and other parts must be ordered from your DTNA facing Parts Distribution Center. For the Cummins engine retrofit see instructions immediately below.

#### **Cummins Engine Retrofit: To order Cummins parts and to receive Cummins work instructions and Cummins claim filing instructions:**

- Contact: Josh Thomas, Cummins Automotive Application Engineer
- Phone: (812) 343-9177
- E-mail: joshua.i.thomas@cummins.com

#### **Include in your email order or have the following information available for phone orders:**

- Full VIN and ESN (Engine Serial Number)
- Shipping address
- Contact name
- Contact phone number
- Contact email

March 2019  
SF561A-F

If our records show your dealership has ordered any vehicle(s) involved in campaign SF561, a list of the customers and vehicle identification numbers will be available on DTNAConnect. Please refer to this list when ordering parts for this campaign.

**Table 1** - Replacement Parts for SF561

<b>Campaign Number</b>	<b>Part Number</b>	<b>Part Description</b>	<b>Qty.</b>	<b>Part Source</b>
SF561A	4394803	ATS ASSEMBLY	1 ea	CUMMINS DISTRIBUTOR
	04-33580-000	BAND-MTG,AFT,ATS,INRAIL,2	2 ea	DTNA FACING PDC
	2866636	DECOMPOSITION PIPE GASKETS-4 INCHES	1 ea	CUMMINS DISTRIBUTOR
	2880482	CLAMP-4 INCH V-BAND	1 ea	CUMMINS DISTRIBUTOR
	ABP N35 100425	ACCUSEAL 4IN. MAGNI COATED CLAMP	1 ea	DTNA FACING PDC
SF561B	4394821	ATS ASSEMBLY	1 ea	CUMMINS DISTRIBUTOR
	04-33580-000	BAND-MTG,AFT,ATS,INRAIL,2	2 ea	DTNA FACING PDC
	2866636	DECOMPOSITION PIPE GASKETS-4 INCHES	1 ea	CUMMINS DISTRIBUTOR
	2880482	CLAMP-4 INCH V-BAND	1 ea	CUMMINS DISTRIBUTOR
	ABP N35 100425	ACCUSEAL 4IN. MAGNI COATED CLAMP	1 ea	DTNA FACING PDC
SF561C	4394917	ATS ASSEMBLY	1 ea	CUMMINS DISTRIBUTOR
	A04-33121-001	BRKT-ISX,1CUS	2 ea	DTNA FACING PDC
	2866337	DECOMPOSITION PIPE GASKETS	1 ea	CUMMINS DISTRIBUTOR
	5290118	DECOMPOSITION PIPE CLAMPS-5 INCH V-BAND	1 ea	CUMMINS DISTRIBUTOR
	01-14596-008	CLAMP-V BAND,TURBOCHARGER, 5.92IN	1 ea	DTNA FACING PDC
SF561D	5418221	ATS ASSEMBLY	1 ea	SUBMIT DTNA WSC TICKET
	A04-33018-003	BRKT-FWD/REAR,ISB/L,FWD	1 ea	DTNA FACING PDC
	A04-33018-004	BRKT-FWD/REAR,ISB/L,AFT	1 ea	DTNA FACING PDC
	2866636	DECOMPOSITION PIPE GASKETS-4 INCHES	1 ea	CUMMINS DISTRIBUTOR
	2880482	CLAMP-4 INCH V-BAND	2 ea	CUMMINS DISTRIBUTOR
SF561E	4394842	ATS ASSEMBLY	1 ea	CUMMINS DISTRIBUTOR
	A04-33018-003	BRKT-FWD/REAR,ISB/L,FWD	1 ea	DTNA FACING PDC
	A04-33018-004	BRKT-FWD/REAR,ISB/L,AFT	1 ea	DTNA FACING PDC
	2866636	DECOMPOSITION PIPE GASKETS-4 INCHES	1 ea	CUMMINS DISTRIBUTOR
	2880482	CLAMP-4 INCH V-BAND	1 ea	CUMMINS DISTRIBUTOR
	01-14596-006	CLAMP-V BAND,TURBOCHARGER,4.91 IN	1 ea	DTNA FACING PDC
SF561F	5418219	ATS ASSEMBLY	1 ea	SUBMIT DTNA WSC TICKET
	A04-33018-002	BRACKET-FWD/REAR,ISB/L,STD	2 ea	DTNA FACING PDC
	2866636	DECOMPOSITION PIPE GASKETS-4 INCHES	1 ea	CUMMINS DISTRIBUTOR
	2880482	CLAMP-4 INCH V-BAND	1 ea	CUMMINS DISTRIBUTOR
	01-14596-006	CLAMP-V BAND,TURBOCHARGER,4.91 IN	1 ea	DTNA FACING PDC

**Removed Parts**

U.S. and Canadian Dealers, please follow Warranty Failed Parts Tracking shipping instructions for the disposition of all removed parts. Export distributors, please destroy removed parts unless otherwise advised.

March 2019  
SF561A-F

## Labor Allowance

**Table 2** - Labor Allowance

Campaign Number	Procedure	Time Allowed (hours)	SRT Code	Corrective Action
SF561A,B	Replace In-Rail ATD and Mounting Bands	2.2	996-F036A	12-Repair Recall/Campaign
SF561C,F	Replace Full Understep ATD and Brackets	2.7	996-F036B	12-Repair Recall/Campaign
SF561D,E	Replace Full Understep ATD and Brackets	3.3	996-F036C	12-Repair Recall/Campaign

**Table 2**

**IMPORTANT:** When the campaign has been completed, locate the base completion label in the appropriate location on the vehicle, and attach the gray completion sticker provided in the field service kit (Form WAR261). If the vehicle does not have a base completion label, clean a spot on the appropriate location of the vehicle and first attach the base completion label (Form WAR259). If a field service kit is not required or there is no completion sticker in the kit, write the campaign number on a blank sticker and attach it to the base completion label.

## Claims for Credit

You will be reimbursed for your parts, labor, and handling (landed cost for Export Distributors) by submitting your claim for SF561 through the Warranty system within 30 days of completing this campaign. You will be reimbursed for the Cummins procedure by submitting your claim directly to Cummins.

**IMPORTANT:** You will submit two claims, one to DTNA (SF651) and one to Cummins.

To submit your claim to Cummins please contact Josh Thomas, Cummins Automotive Application Engineer for instructions (see instructions under Replacement Parts on page 1).

For the DTNA SF561 claim please reference the following information in OWL:

- Claim type is **Field Service Campaign**.
- In the Campaign field, enter the campaign number and appropriate group (**SF561-A, SF561-B, etc.**).
- In the Primary Failed Part field, enter **25-SF561-000**.
- In the Parts section, enter the appropriate part number(s) as shown in the Replacement Parts Table.
- In the Labor section, enter the appropriate SRT from the Labor Allowance Table. Administrative time will be included automatically as SRT 939-6010A for 0.3 hours.
- The VMRS Component Code is **043-006-001**, and the Cause Code is **A1 - Campaign**.
- This Field Service Campaign will **terminate on March 31, 2020**. Dealers will be notified of any changes to the termination date via an Important Campaign Information Letter posted on DTNAConnect.com.

**IMPORTANT:** OWL must be viewed prior to beginning work to ensure the vehicle is involved and the campaign has not previously been completed. Also, check for a completion sticker before beginning work.

All claims must be submitted within 30 days of the repair and within 30 days of the termination date of the campaign. U.S. and Canadian Dealers: All excess inventory to be returned to the PDC following the conclusion of the campaign must be returned in resalable condition to the Memphis PDC within 90 days from the termination date. Please submit a PAR to request return to the Memphis PDC. (Canadian dealers should return the kits to their facing PDC.) Export Distributors: Excess inventory is not returnable.

For questions, U.S. and Canadian dealers, contact the Warranty Campaigns Department via Web inquiry at DTNAConnect.com / WSC, or the Customer Assistance Center at (800) 385-4357, after normal business hours, if you have any questions or need additional information. Export distributors submit a Web inquiry or contact your International Service Manager.

March 2019  
SF561A-F

## Copy of Notice to Owners

### **Subject: Cummins Greenhouse Gas 2017 Engine Aftertreatment System Retrofit**

Daimler Trucks North America, LLC (DTNA), on behalf of its Freightliner Truck Division and its wholly-owned subsidiary, Western Star Truck Sales, Inc., is initiating Field Service Campaign SF561A-F to modify specific Freightliner 108SD, Business Class M2, and Cascadia model vehicles and Western Star 4700 and 4900 model vehicles, manufactured August 1, 2016, through August 22, 2016.

Certain pre-series vehicles have early-design aftertreatment devices (ATD) and/or ATD brackets.

Vehicles will have the ATD and/or ATD brackets replaced. **IMPORTANT: Advance arrangements are required for this field service campaign to ensure parts will be available for your vehicle.**

In addition to SF561, Cummins advises that their pre-series engine retrofit be done at the same time. Your DTNA dealer can complete this Cummins procedure along with SF561.

Please contact an authorized Daimler Trucks North America dealer to arrange to have the campaign performed and to ensure that parts are available at the dealership. To locate an authorized dealer, search online at [Daimler-TrucksNorthAmerica.com](http://Daimler-TrucksNorthAmerica.com). On the menu tab, select "Contact Us," scroll down to "Locate a Dealer," and select the appropriate brand. The campaign will take approximately three to four hours and will be performed at no charge to you.

This Field Service Campaign will **terminate on March 31, 2020**. Please make sure the campaign is completed prior to this date. Work completed after this date will be done at the customer's expense.

As stated in the terms of your express limited warranty, Daimler Trucks North America, LLC will not pay for any damage caused by failure to properly maintain your vehicle. Daimler Trucks North America, LLC considers the work necessary under this campaign to be proper maintenance and will, therefore, not pay for any damage to your vehicle caused by your failure to have the repairs that are the subject of this campaign performed in a reasonable time.

Contact the Warranty Campaigns Department at (800) 547-0712, from 7 a.m. to 4 p.m. Pacific Time, Monday through Friday, e-mail address [DTNA.Warranty.Campaigns@Daimler.com](mailto:DTNA.Warranty.Campaigns@Daimler.com), or contact the Customer Assistance Center at (800) 385-4357, after normal business hours, if you have any questions or need additional information.

WARRANTY CAMPAIGNS DEPARTMENT

Enclosure

March 2019  
SF561A-F

## Work Instructions

### Subject: Cummins Greenhouse Gas 2017 Engine Aftertreatment System Retrofit

**Models Affected:** Specific Freightliner 108SD, Business Class M2, and Cascadia model vehicles and Western Star 4700 and 4900 model vehicles, manufactured August 1, 2016, through August 22, 2016.

#### **WARNING**

Aftertreatment Device (ATD) internal temperatures can remain hot enough to cause personal injury, or ignite combustible materials, for hours after the engine is shut down.

To avoid potentially serious burns or material damage:

- Let the ATD cool before handling it.
  - Wear appropriate protective gear.
  - Be careful not to place the ATD where flammable gases or other combustible materials may come into contact with hot interior parts.
1. Check the base label (Form WAR259) for a completion sticker for SF561 (Form WAR261) indicating this work has been done. The base label is usually located on the passenger-side door, about 12 inches (30 cm) below the door latch. If a completion sticker is present, no work is needed. If a completion sticker is not present, proceed to the next step.
  2. Perform the appropriate procedure based on the vehicle group:
    - **SF561-A and SF561-B: In-Rail Aftertreatment Device Replacement (Page 5)**
    - **SF561-C and SF561-F: Full Understep Aftertreatment Assembly Replacement (Page 7)**
    - **SF561-D and SF561-E: Full Understep Aftertreatment Assembly Replacement for AWD Vehicles (Page 9)**

## SF561-A and SF561-B: In-Rail Aftertreatment Device Replacement

Refer to [Fig. 1](#) for this procedure.

1. Shut down the engine, set the parking brake, and chock the tires.
2. Allow the ATD time to cool.
3. Disconnect the DEF lines. Cut the tie straps that attach the DEF lines to the ATD mounting brackets.
4. Disconnect the wire harness to the control module on the ATD. Cut the tie straps that attach the wiring to the ATD mounting brackets.
5. Remove the spherical clamp and gasket that connect the ATD inlet pipe to the ATD. Discard the clamp and gasket.
6. Remove the spherical clamp and gasket that connect the ATD to the outlet pipe. Discard the clamp and gasket.
7. Position the jack and cradle under the assembly and secure it with straps.
8. Remove the clamping bolts and nuts from the clamping straps.
9. Lower the unit, making sure the sensor wires do not get caught on the mounting brackets.

March 2019  
SF561A-F

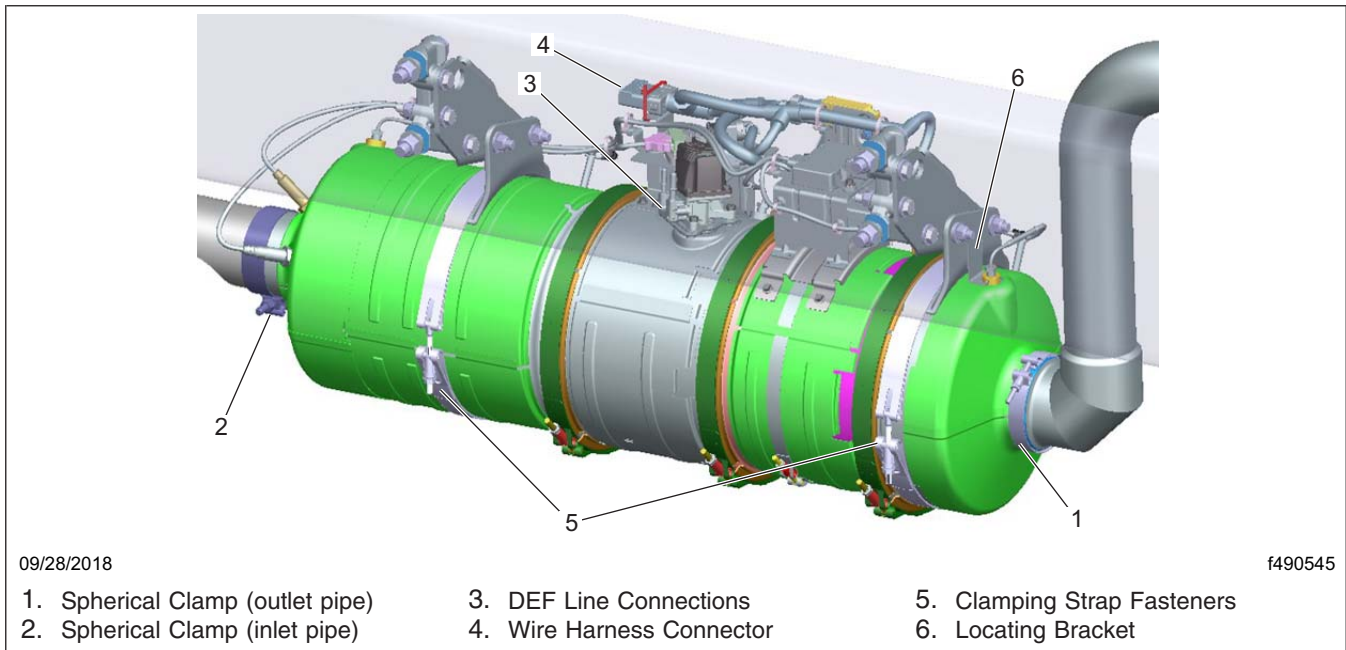

**Fig. 1, In-Rail ATD (SF561-A and SF561-B)**

10. Remove and discard the clamping straps and hardware.
  11. Position the new ATD assembly in the jack cradle and secure it with straps.
  12. Slide the unit under the vehicle and raise it into position.
  13. Install new clamping straps on the vehicle.
  14. Position the ATD assembly in the clamping straps, using the locating bracket to orient the ATD, then install the clamping bolts and nuts. Do not tighten at this time.
- IMPORTANT:** Always use new gaskets when installing exhaust system components.
15. Connect the ATD to the ATD inlet pipe and install the new spherical clamp and gasket. Do not tighten at this time.
  16. Connect the ATD to the outlet pipe and install the new spherical clamp and gasket. Do not tighten at this time.
  17. Check the alignment of all components. Make adjustments to the clamping straps as needed, then incrementally tighten the bolts 15 lbf-ft (20 N-m), then 30 lbf-ft (41 N-m).
  18. Tighten the spherical clamps at the connections to the ATD inlet pipe and the mix tube as follows:
    - 18.1 Tighten the nut 126 to 138 lbf-in (1425 to 1560 N-cm).
    - 18.2 Using a plastic or rubber mallet, tap around the outside of the clamp to seat the clamp against the pipe.
    - 18.3 Tighten the nut a second time 126 to 138 lbf-in (1425 to 1560 N-cm).
  19. Connect the wiring harness to the control module on the ATD. Attach the wiring to the ATD mounting brackets with tie straps.
  20. Connect the DEF lines. Attach the DEF lines to the ATD mounting brackets with tie straps.
  21. Remove the jack and cradle.
  22. Start the engine and check for leaks. Further tighten the clamps on any leaking connections as needed.
  23. Clean a spot on the base label (Form WAR259). Write the campaign number, SF561, on a blank grey completion sticker (Form WAR261) to indicate the work has been completed, and attach it to the base label.

March 2019  
SF561A-F

## SF561-C and SF561-F: Full Understep Aftertreatment Assembly Replacement

Refer to [Fig. 2](#) and [Fig. 3](#) for this procedure.

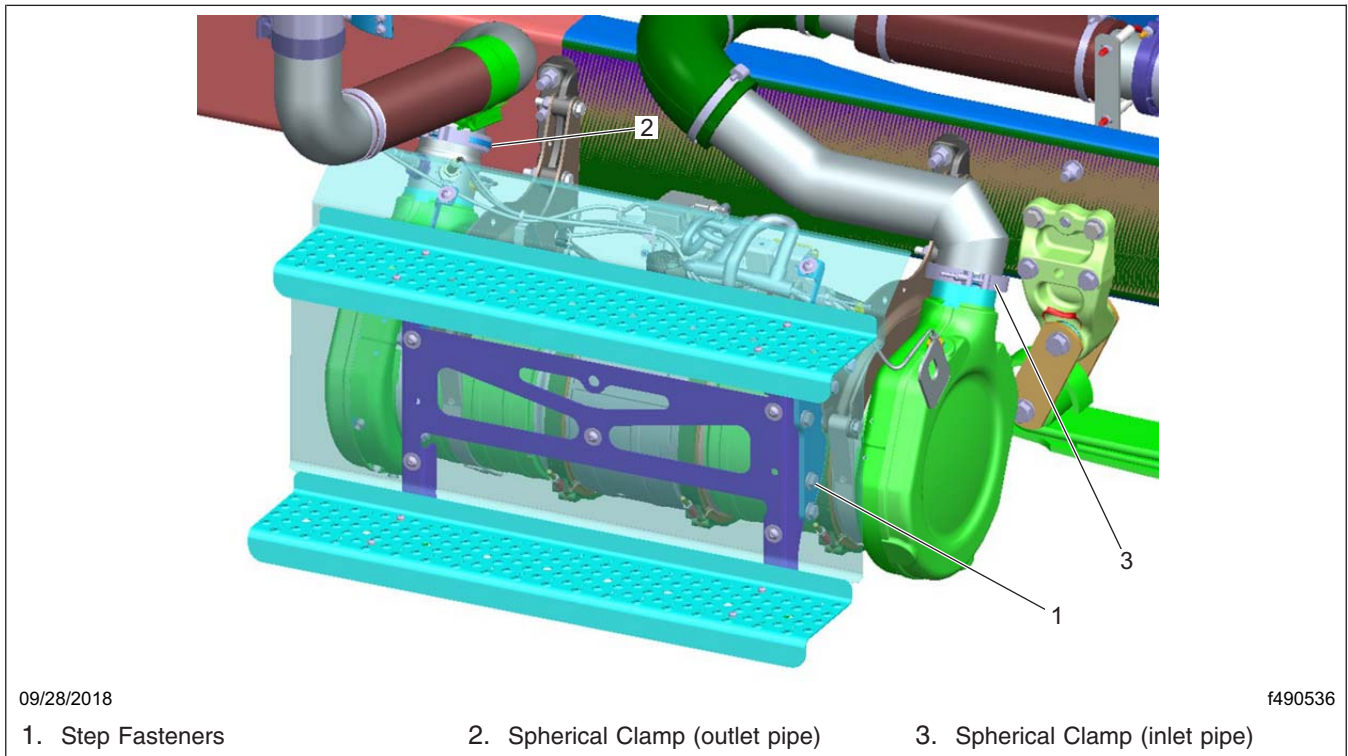

**Fig. 2, Understep Aftertreatment Assembly Installation (Populations C and F)**

1. Shut down the engine, set the parking brake, and chock the tires.
2. Allow the ATD time to cool.
3. Raise the hood.
4. Remove the fasteners that attach the steps to the mounting brackets. Remove the steps.
5. Disconnect the DEF lines. Cut the tie straps that attach the DEF lines to the ATD mounting brackets.
6. Disconnect the wire harness to the control module on the ATD. Cut the tie straps that attach the wiring to the ATD mounting brackets.
7. Remove the spherical clamp and gasket that connect the ATD inlet pipe to the ATD. Discard the clamp and gasket.
8. Remove the spherical clamp and gasket that connect the ATD to the outlet pipe. Discard the clamp and gasket.
9. Position the jack and cradle under the assembly and secure it with straps.
10. Remove the frame fasteners.

March 2019  
SF561A-F

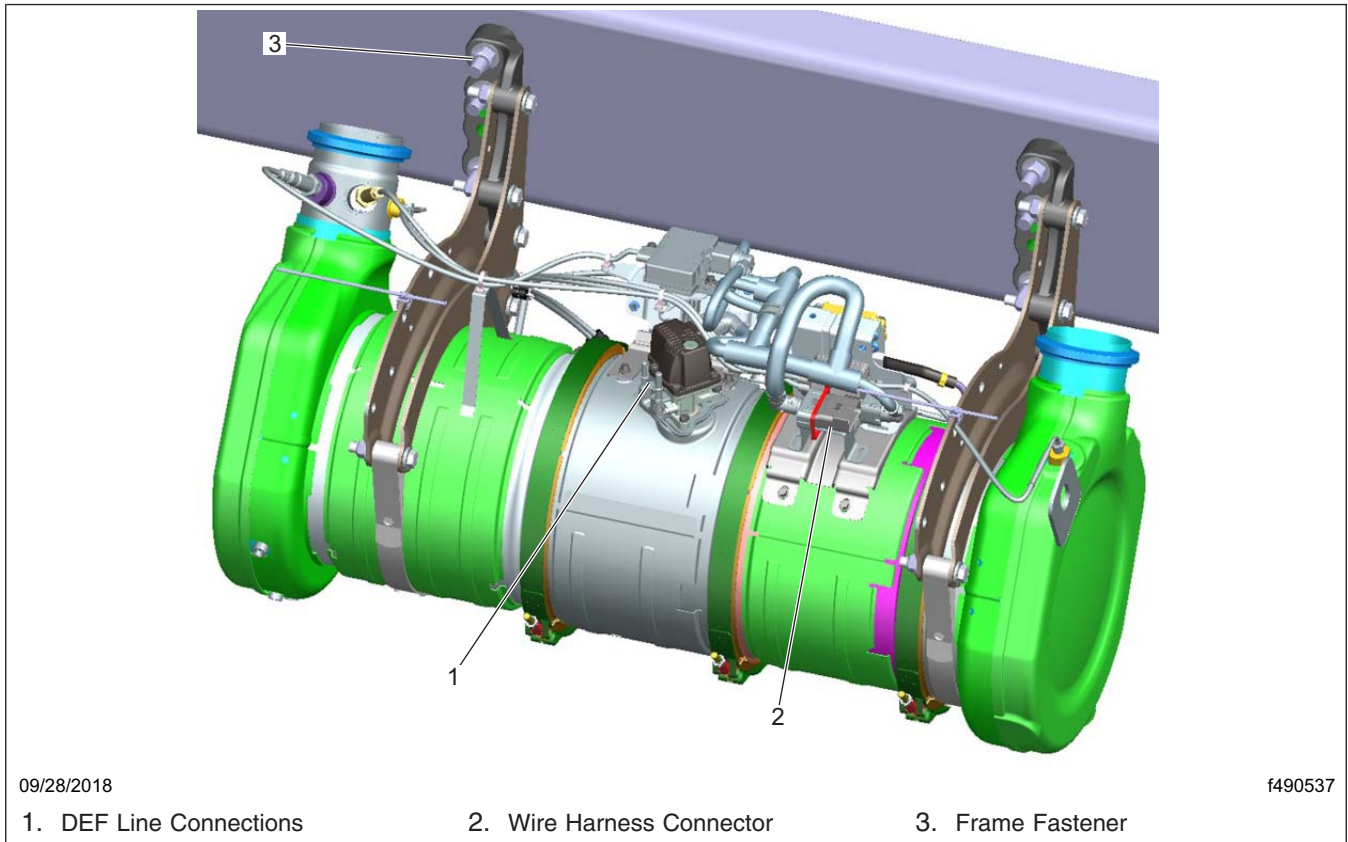

**Fig. 3, Understep Aftertreatment Assembly (SF561-C and SF561-F)**

11. Lower the unit.
12. Position the new ATD assembly in the jack cradle and secure it with straps.
13. Slide the unit under the vehicle and raise it into position.
14. Attach the ATD assembly to the frame.

**IMPORTANT:** Always use new gaskets when installing exhaust system components.

15. Connect the ATD to the ATD inlet pipe and install the new spherical clamp and gasket. Do not tighten at this time.
16. Connect the ATD to the outlet pipe and install the new spherical clamp and gasket. Do not tighten at this time.
17. Check the alignment of all components.
18. Tighten the spherical clamps at the connections to the ATD inlet pipe and the outlet pipe as follows:
  - 18.1 Tighten the nut 114 to 126 lbf·in (1290 to 1425 N·cm).
  - 18.2 Using a plastic or rubber mallet, tap around the outside of the clamp to seat the clamp against the pipe.
  - 18.3 Tighten the nut a second time 114 to 126 lbf·in (1290 to 1425 N·cm).
19. Connect the wiring harness to the control module on the ATD. Attach the wiring to the ATD mounting brackets with tie straps.



March 2019  
SF561A-F

20. Connect the DEF lines. Attach the DEF lines to the ATD mounting brackets with tie straps.
21. Remove the jack and cradle.
22. Start the engine and check for leaks. Further tighten the clamps on any leaking connections as needed.
23. Clean a spot on the base label (Form WAR259). Write the campaign number, SF561, on a blank grey completion sticker (Form WAR261) to indicate the work has been completed, and attach it to the base label.

## SF561-D and SF561-E: Full Understep Aftertreatment Assembly Replacement for AWD Vehicles

Refer to [Fig. 4](#) and [Fig. 5](#) for this procedure.

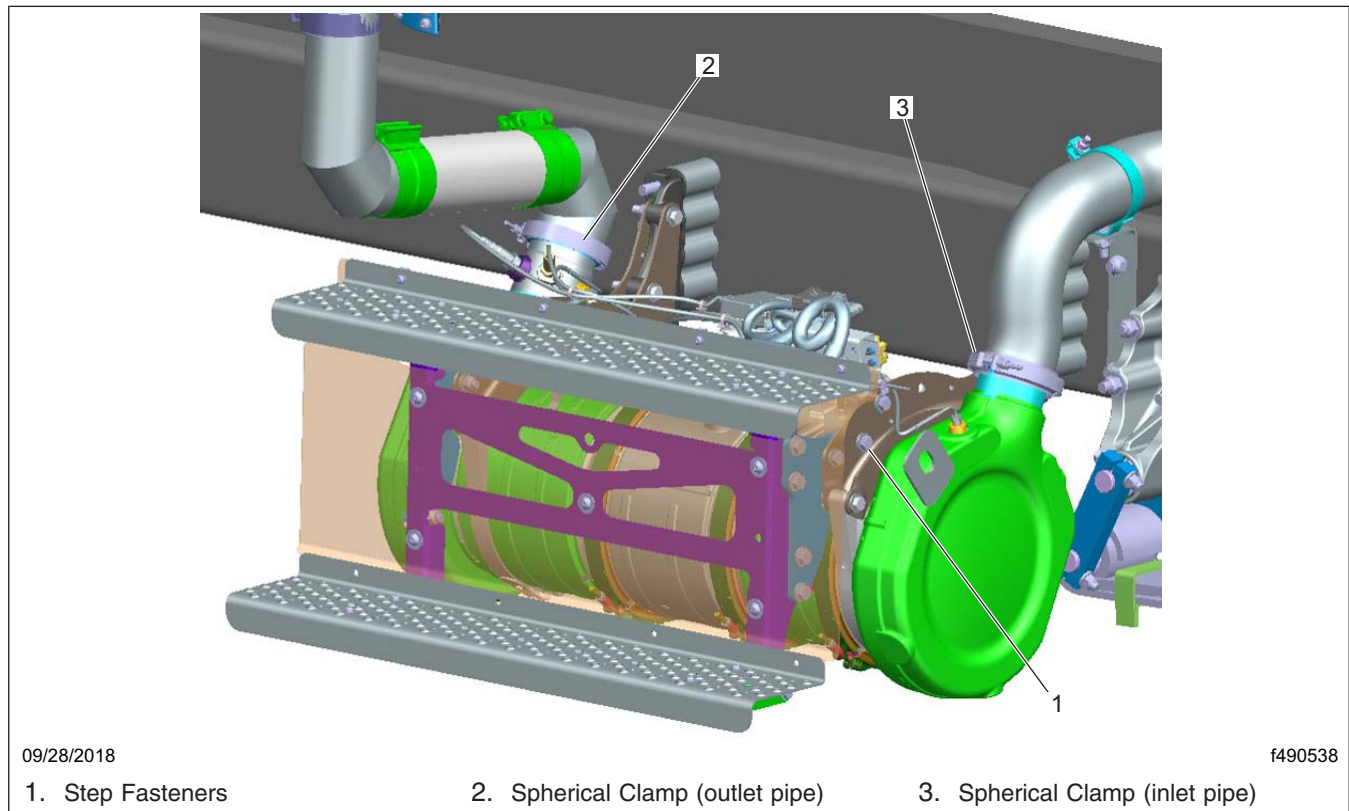

**Fig. 4, Understep Aftertreatment Assembly Installation (SF561-D and SF561-E)**

1. Shut down the engine, set the parking brake, and chock the tires.
2. Allow the ATD time to cool.
3. Raise the hood.
4. Remove the fasteners that attach the steps to the step mounting brackets. Remove the steps.
5. Disconnect the DEF lines. Cut the tie straps that attach the DEF lines to the ATD mounting brackets.
6. Disconnect the wire harness to the control module on the ATD. Cut the tie straps that attach the wiring to the ATD mounting brackets.

March 2019  
SF561A-F

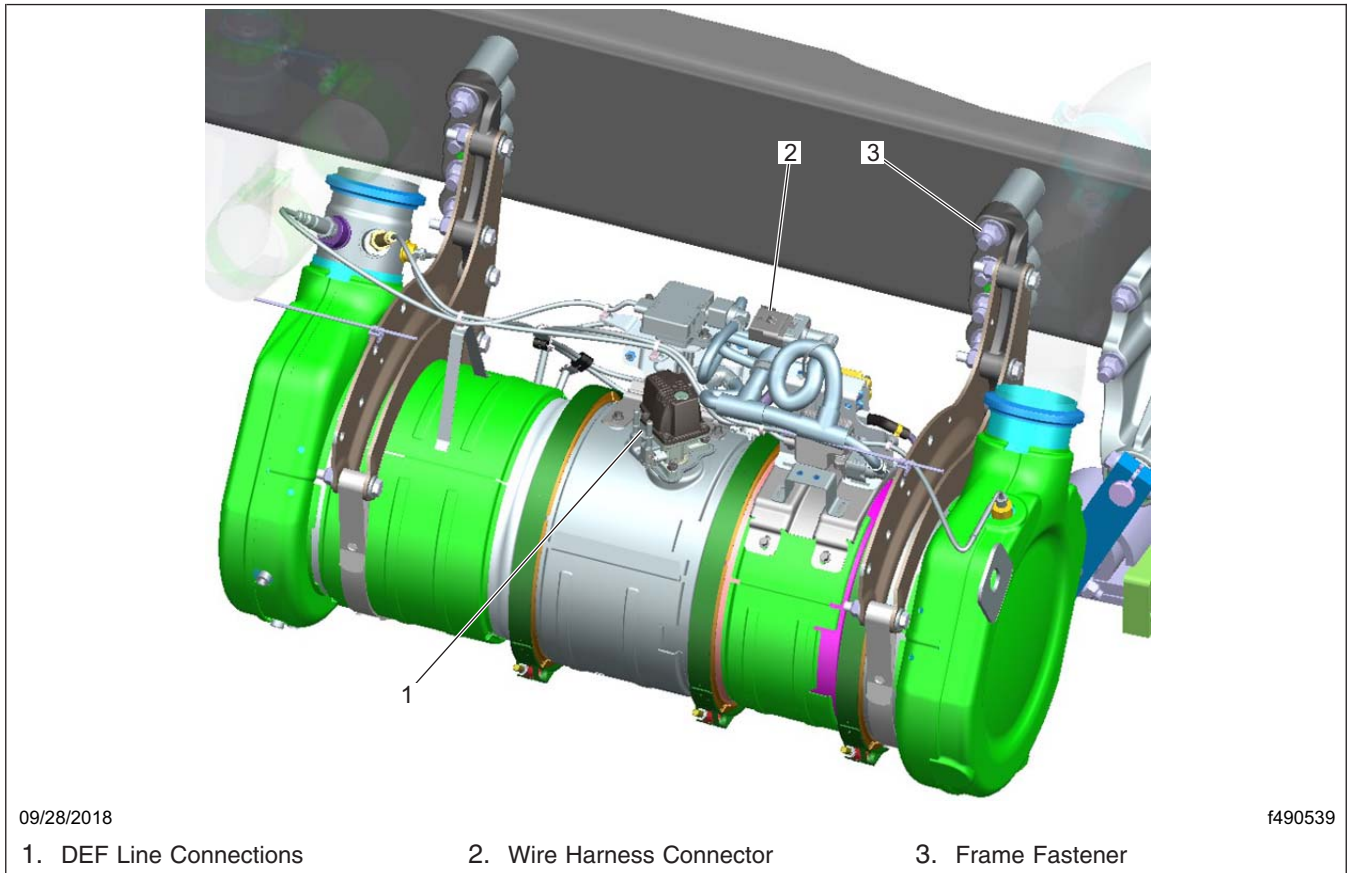

**Fig. 5, Understep Aftertreatment Assembly (SF561-D and SF561-E)**

7. Remove the spherical clamp and gasket that connect the ATD inlet pipe to the ATD. Discard the clamp and gasket.
8. Remove the spherical clamp and gasket that connect the ATD to the outlet pipe. Discard the clamp and gasket.
9. Position the jack and cradle under the assembly and secure it with straps.
10. Remove the frame fasteners.
11. Lower the unit.

NOTE: The new ATD brackets for AWD vehicle require four additional holes to be drilled in the frame rail. See [Fig. 6](#).

12. Locate and drill four new 11/16 inch (17.46 mm) diameter holes as shown in [Fig. 7](#).
13. Position the new ATD assembly in the jack cradle and secure it with straps.
14. Slide the unit under the vehicle and raise it into position.
15. Attach the ATD assembly to the frame.

IMPORTANT: Always use new gaskets when installing exhaust system components.

16. Connect the ATD to the ATD inlet pipe and install the new spherical clamp and gasket. Do not tighten at this time.

March 2019  
SF561A-F

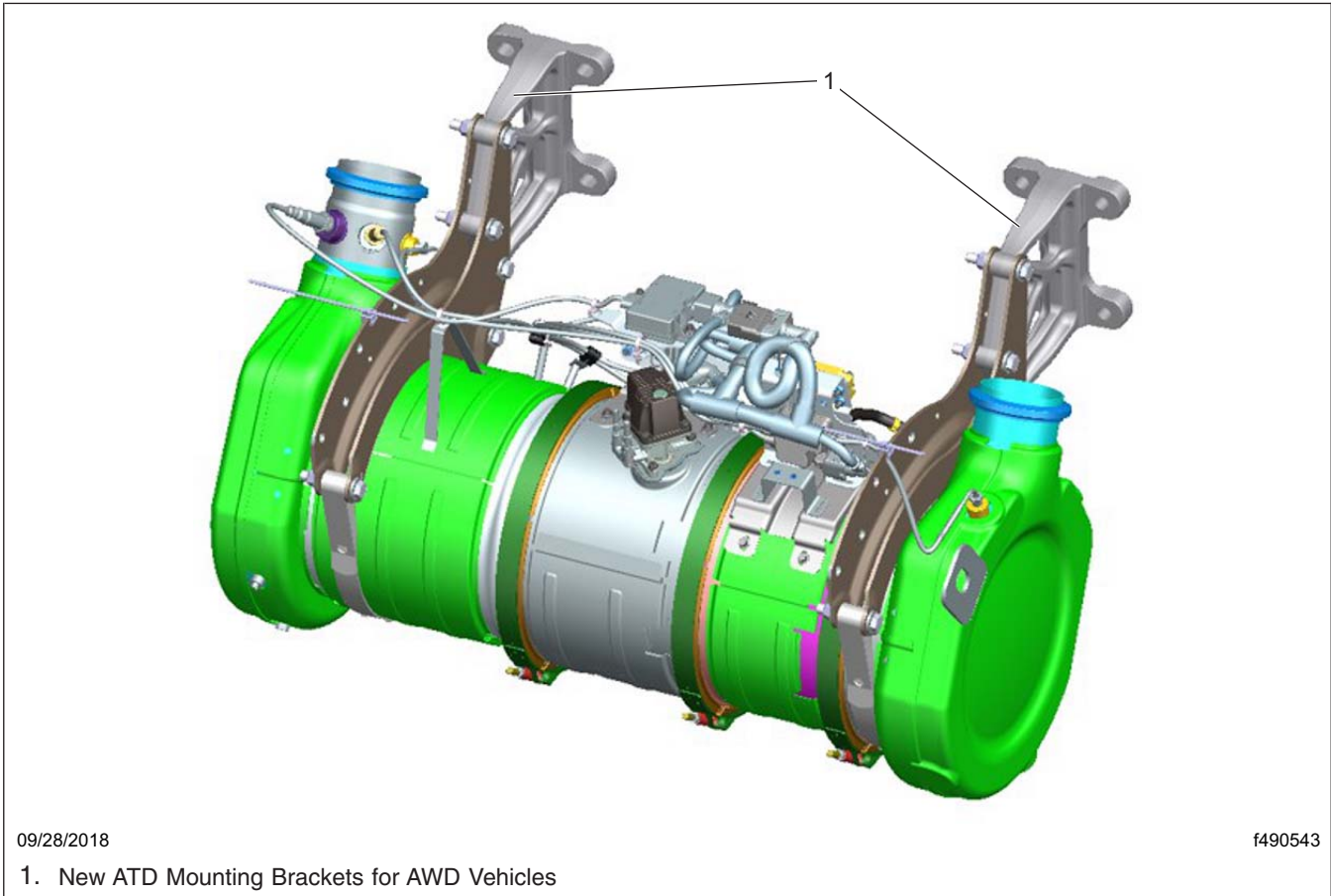

**Fig. 6, ATD with New Mounting Brackets (SF561-D and SF561-E)**

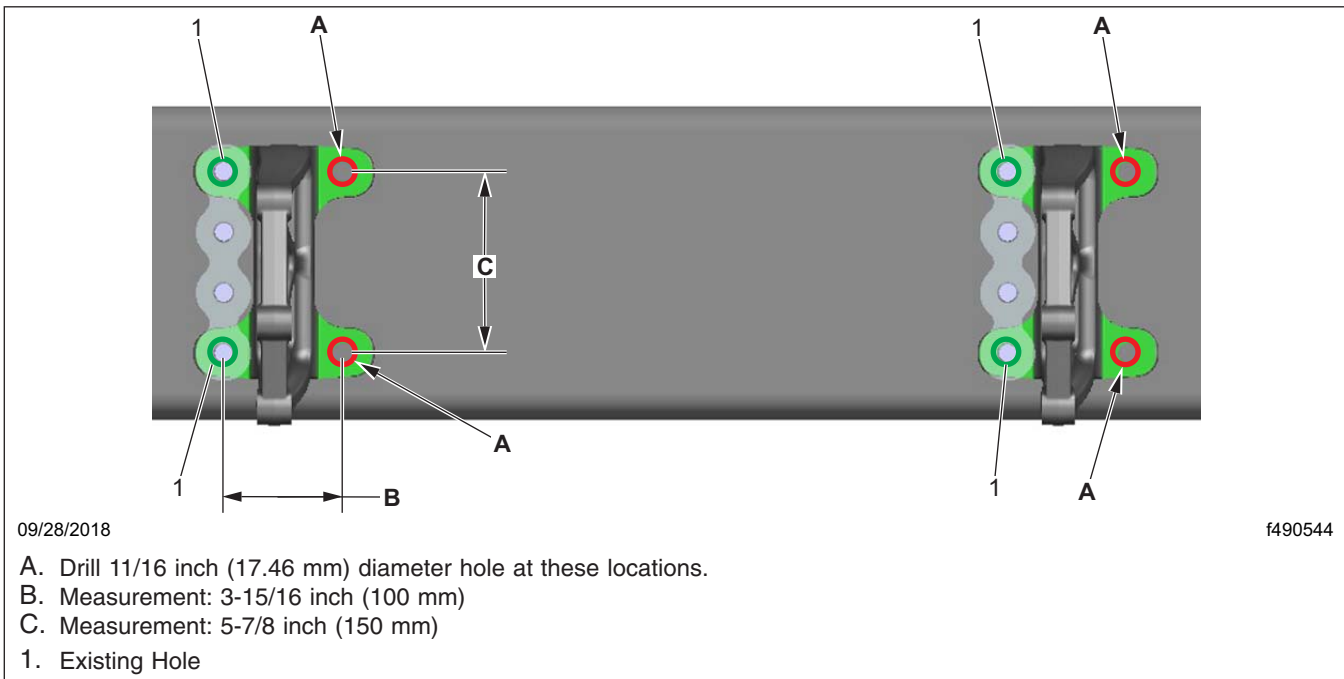

**Fig. 7, Frame Drilling Locations (SF561-D and SF561-E)**

**March 2019  
SF561A-F**

17. Connect the ATD to the outlet pipe and install the new spherical clamp and gasket. Do not tighten at this time.
18. Check the alignment of all components.
19. Tighten the spherical clamps at the connections to the ATD inlet pipe and the outlet pipe as follows:
  - 19.1 Tighten the nut 114 to 126 lbf·in (1290 to 1425 N·cm).
  - 19.2 Using a plastic or rubber mallet, tap around the outside of the clamp to seat the clamp against the pipe.
  - 19.3 Tighten the nut a second time 114 to 126 lbf·in (1290 to 1425 N·cm).
20. Connect the wiring harness to the control module on the ATD. Attach the wiring to the ATD mounting brackets with tie straps.
21. Connect the DEF lines. Attach the DEF lines to the ATD mounting brackets with tie straps.
22. Remove the jack and cradle.
23. Start the engine and check for leaks. Further tighten the clamps on any leaking connections as needed.
24. Clean a spot on the base label (Form WAR259). Write the campaign number, SF561, on a blank grey completion sticker (Form WAR261) to indicate the work has been completed, and attach it to the base label.