

<b>Subject:</b> <b>IGNITION DOES NOT TURN OFF WHEN PRESSING START / STOP BUTTON (WITH GATE-TYPE AT SHIFTER)</b>	<b>Bulletin No.:</b> 05-003/19
	<b>Last Issued:</b> 05/06/2019

## BULLETIN NOTES

This bulletin supersedes the previously issued bulletin(s) listed below. The changes are noted below in Red.

Previous TSBs:	Date(s) Issued:
05-004/16	04/11/2016
05-007/15	12/22/2015

## APPLICABLE MODEL(S)/VINS

2013-2014 CX-5 vehicles with VINs lower than JM3KE\*\*\*\*\*430747 (produced before Dec. 27, 2013)  
 2014 Mazda6 vehicles with VINs lower than JM1GJ\*\*\*\*\*162747 (produced before Nov. 29, 2013)

## DESCRIPTION

When pressing the START/STOP button, the ignition may not turn off on some vehicles equipped with a gate-type AT shifter. Although the shift lever is in "P" position and the engine shuts off normally, the ignition may stay on (in accessory mode). Some customers may describe this concern as "the radio stays on" or "the radio is staying on".

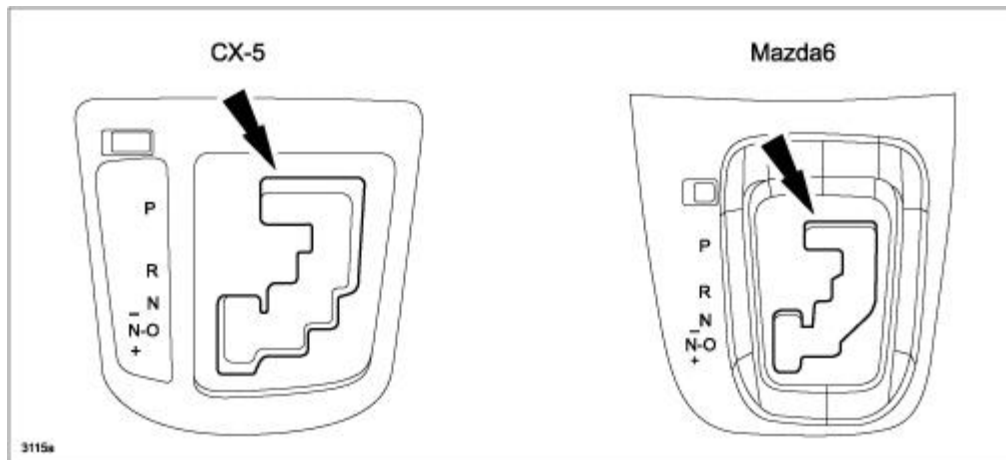

**CONSUMER NOTICE:** The information and instructions in this bulletin are intended for use by skilled technicians. Mazda technicians utilize the proper tools/equipment and take training to correctly and safely maintain Mazda vehicles. These instructions should not be performed by "do-it-yourselfers." Customers should not assume this bulletin applies to their vehicle or that their vehicle will develop the described concern. To determine if the information applies, customers should contact their nearest authorized Mazda dealership. Mazda North American Operations reserves the right to alter the specifications and contents of this bulletin without obligation or advance notice. All rights reserved. No part of this bulletin may be reproduced in any form or by any means, electronic or mechanical---including photocopying and recording and the use of any kind of information storage and retrieval system ---without permission in writing.

This concern may be caused by a worn switch unit. To eliminate this concern, the switch unit material has been changed to improve wear resistance. Modified switch units have been established as new service parts.

Customers having this concern should have their vehicle repaired using the following repair procedure.

## REPAIR PROCEDURE

1. Verify the customer concern.
2. Remove Mazda6 front console box (A) or CX-5 rear console (A) according to the instructions on MGSS online or the Workshop Manual to access the switch unit (B):

**MAZDA6 FRONT CONSOLE BOX:** (section 09-17 FRONT CONSOLE BOX REMOVAL/INSTALLATION).

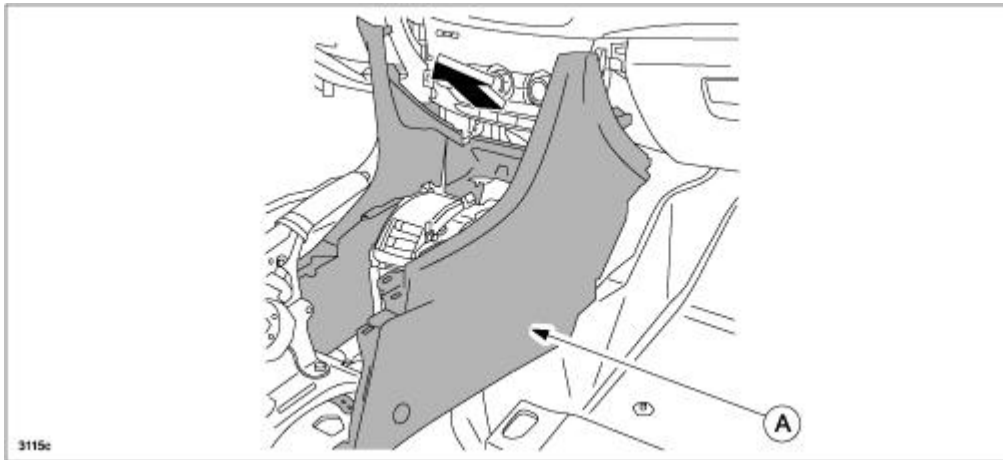

**CX-5 REAR CONSOLE:** (section 09-17 REAR CONSOLE REMOVAL/INSTALLATION).

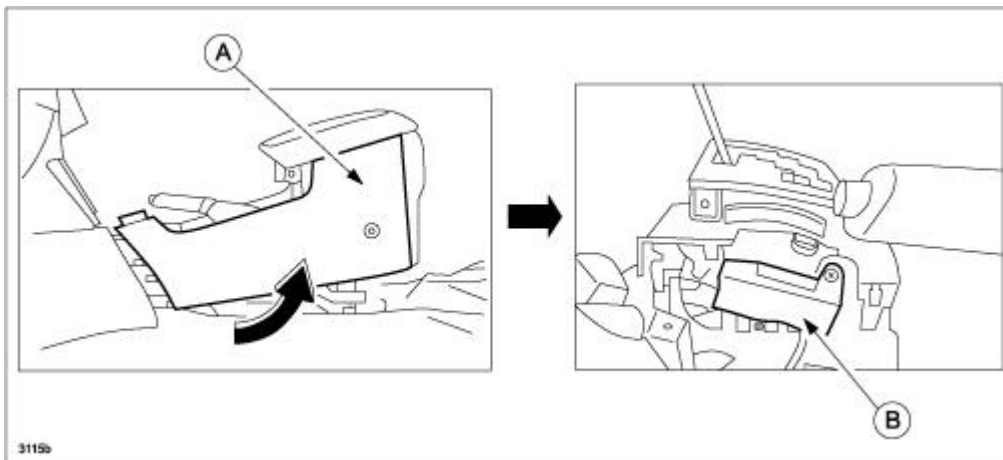

3. Detach (4) four hooks (A) (2 hooks shown below), then remove the set plate assembly (B).

**CONSUMER NOTICE:** The information and instructions in this bulletin are intended for use by skilled technicians. Mazda technicians utilize the proper tools/equipment and take training to correctly and safely maintain Mazda vehicles. These instructions should not be performed by "do-it-yourselfers." Customers should not assume this bulletin applies to their vehicle or that their vehicle will develop the described concern. To determine if the information applies, customers should contact their nearest authorized Mazda dealership. Mazda North American Operations reserves the right to alter the specifications and contents of this bulletin without obligation or advance notice. All rights reserved. No part of this bulletin may be reproduced in any form or by any means, electronic or mechanical---including photocopying and recording and the use of any kind of information storage and retrieval system ---without permission in writing.

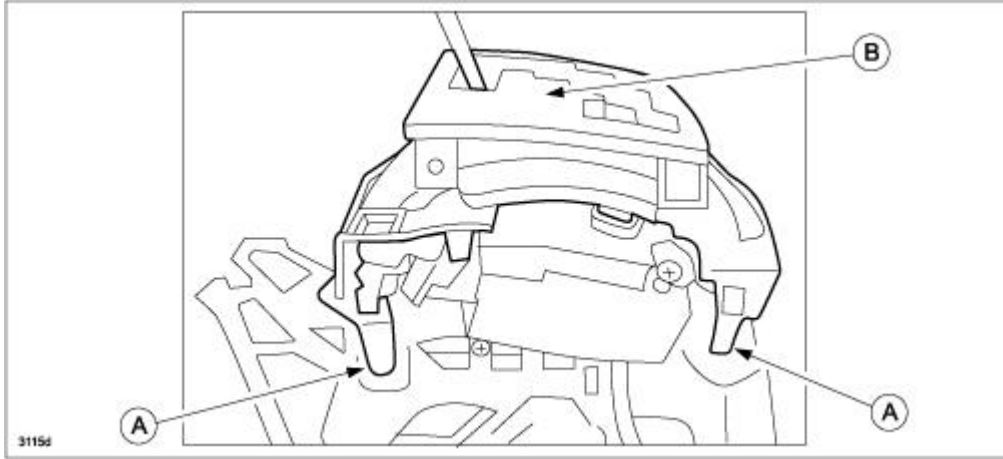

**NOTE:** In these illustrations, the shift lever component is shown removed from the vehicle for viewing purposes only. It is not necessary to remove it from the vehicle during this repair.

4. Detaching (2) two hooks (A) pull out the shift lock over-ride lever (B).

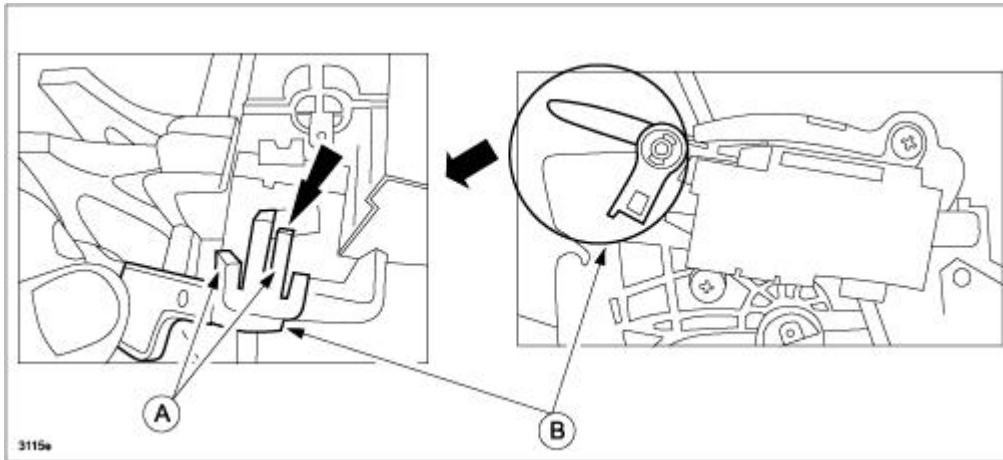

5. Remove (2) two screws (A). While pushing the stopper (B) down, remove the switch unit (C).

6. Disconnect the switch unit connector (D).

**CONSUMER NOTICE:** The information and instructions in this bulletin are intended for use by skilled technicians. Mazda technicians utilize the proper tools/equipment and take training to correctly and safely maintain Mazda vehicles. These instructions should not be performed by "do-it-yourselfers." Customers should not assume this bulletin applies to their vehicle or that their vehicle will develop the described concern. To determine if the information applies, customers should contact their nearest authorized Mazda dealership. Mazda North American Operations reserves the right to alter the specifications and contents of this bulletin without obligation or advance notice. All rights reserved. No part of this bulletin may be reproduced in any form or by any means, electronic or mechanical---including photocopying and recording and the use of any kind of information storage and retrieval system ---without permission in writing.

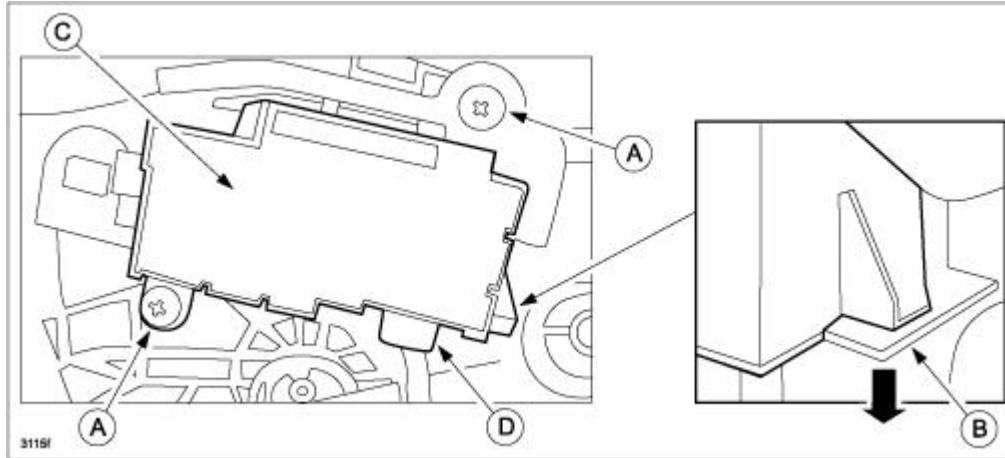

7. Install a new switch unit in the reverse order of removal.

**NOTE:** Use the new screws that came with the new switch unit.

8. Tighten the screws to the correct torque specification.

**Tightening Torque: 10.6-14.2 in. lbf. {1.2-1.6 N-m, 12.2-16.3 kgf-cm}**

**CAUTION:** Over tightening the screws may cause breakage of the plastic parts.

9. Re-install other parts in the reverse order of removal.

10. Verify the repair.

**CONSUMER NOTICE:** The information and instructions in this bulletin are intended for use by skilled technicians. Mazda technicians utilize the proper tools/equipment and take training to correctly and safely maintain Mazda vehicles. These instructions should not be performed by "do-it-yourselfers." Customers should not assume this bulletin applies to their vehicle or that their vehicle will develop the described concern. To determine if the information applies, customers should contact their nearest authorized Mazda dealership. Mazda North American Operations reserves the right to alter the specifications and contents of this bulletin without obligation or advance notice. All rights reserved. No part of this bulletin may be reproduced in any form or by any means, electronic or mechanical---including photocopying and recording and the use of any kind of information storage and retrieval system ---without permission in writing.

## PARTS INFORMATION

Part Number	Description	Qty.	Applicable Select Lever Assembly
KDY0-46-040	Switch Unit	1	KD31-46-100D GHR5-46-100C

**NOTE:** The Applicable Select Lever Assembly part numbers listed above are for reference only. Do not order these parts for this repair. It is only necessary to order the Switch Unit.

## WARRANTY INFORMATION

### NOTE:

- This warranty information applies only to verified customer complaints on vehicles eligible for warranty repair.
- This repair will be covered under Mazda's New Vehicle Limited Warranty term.
- Additional diagnostic time cannot be claimed for this repair.

	CX-5	Mazda6
Warranty Type	A	A
Symptom Code	62	62
Damage Code	9C	9C
Part Number Main Cause	KDY0-46-040	KDY0-46-040
Quantity	1	1
Operation Number / Labor Hours:	XXL96BRX / 0.3 Hrs.	XXL96ARX / 0.4 Hrs.

**CONSUMER NOTICE:** The information and instructions in this bulletin are intended for use by skilled technicians. Mazda technicians utilize the proper tools/equipment and take training to correctly and safely maintain Mazda vehicles. These instructions should not be performed by "do-it-yourselfers." Customers should not assume this bulletin applies to their vehicle or that their vehicle will develop the described concern. To determine if the information applies, customers should contact their nearest authorized Mazda dealership. Mazda North American Operations reserves the right to alter the specifications and contents of this bulletin without obligation or advance notice. All rights reserved. No part of this bulletin may be reproduced in any form or by any means, electronic or mechanical---including photocopying and recording and the use of any kind of information storage and retrieval system ---without permission in writing.