



Service Bulletin

Bulletin No.: 17-NA-166

Date: April, 2019

TECHNICAL

Subject: Rough Idle in Drive

This Bulletin replaces PIP5211F. Please discard PIP5211F.

Brand:	Model:	Model Year:		VIN:		Engine:	Transmission:
		from	to	from	to		
Cadillac	Escalade Models	2015	2019			L83, L86, LV1, LV3 (4.3L, 5.3L, 6.2L)	All
Chevrolet	Silverado	2014	2018				
	Silverado LD	2019	2019				
	Suburban	2015	2019				
	Tahoe						
GMC	Sierra	2014	2018				
	Sierra Limited	2019	2019				
GMC	Yukon Models	2015	2019				

Involved Region or Country	North America and N.A. Export Regions
Condition	<p>Some customers may comment about a rough idle and/or vibration at idle in Drive. This condition may be most noticeable following extended driving, after hard acceleration, while idling at a stop in Drive.</p> <p>May feel like a lopey or lumpy idle, or may be described as a low idle.</p> <p>This condition will not be present in Park or Neutral. (There have been a few cases for rough idle in Reverse.)</p> <p>Note: There will not be any DTCs with this concern.</p>

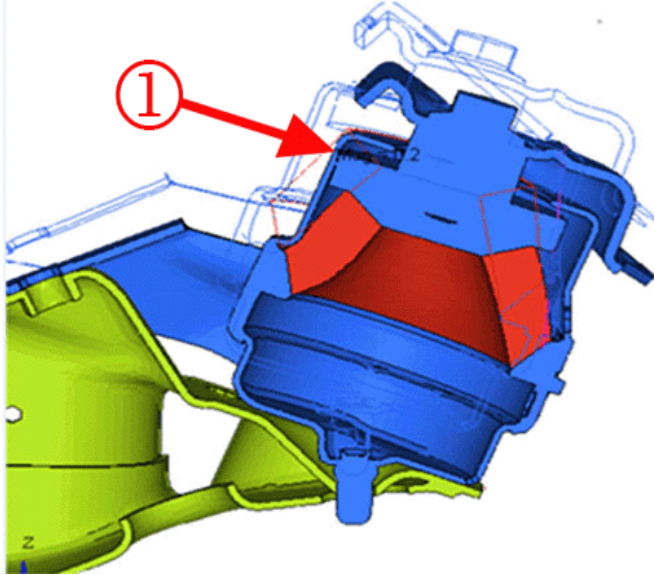
<p>Cause</p>	 <p style="text-align: right;">4787059</p> <p>This concern may be caused by ground out (1) within one or both engine mounts.</p>
<p>Correction</p>	<p>Important: Familiarize yourself with this entire bulletin before proceeding to ensure you are diagnosing and focusing on the correct issue by frequency measured with Pico scope.</p> <p>Perform PICO analysis, refer to the Service Procedure section below.</p> <p>⇒ If the rough idle / vibration concern frequency is E1.5 in the horizontal / lateral direction with Pico sensor mounted in seat track as indicated below – continue with steps to install updated design engine mounts and settle both engine and trans mounts to reduce amplitude (mg) / eliminate ground out within the engine mounts for vehicles built prior to engine mount breakpoint. For vehicles built after breakpoint, follow Shimming Procedure for Engine Mount Vibration/Grounding after Mount Replacement.</p> <p>Important: The updated engine mounts are designed to reduce internal ground out, primarily E1.5. These mounts along with engine and trans mount settling will typically reduce amplitude at the seat track to 2 mg or less.</p> <p>Note: The 6.2L engine has a characteristic E1 which can be felt, and may be described as a lopey idle. V-8 engine firing frequency produces E4 which will typically be very low frequency at the seat track. Do not confuse 6.2L E1 characteristic (not caused by mount ground-out), with E1.5 normal idle characteristics being transmitted into the truck via ground-out through the engine mounts.</p>

Service Procedure

Initial Setup / Duplication / Evaluation:

Measure the vibration disturbance using the vibration analyzer, CH-51450-A (Pico Oscilloscope), to qualify whether the issue frequency is E1.5 as opposed to E1 or E4.

Note: If using a single-axis pico sensor, mount and test both vertically and horizontally – E1.5 rough idle vibration will usually be horizontal / lateral at the seat track.





4532456

(TA183 single axis pico sensor shown / TA143 is tri-axis sensor)

Add E1.5 to the displayed data and turn Off T and P related data (under Add Vibration in Pico) since issue occurs with vehicle stationary.

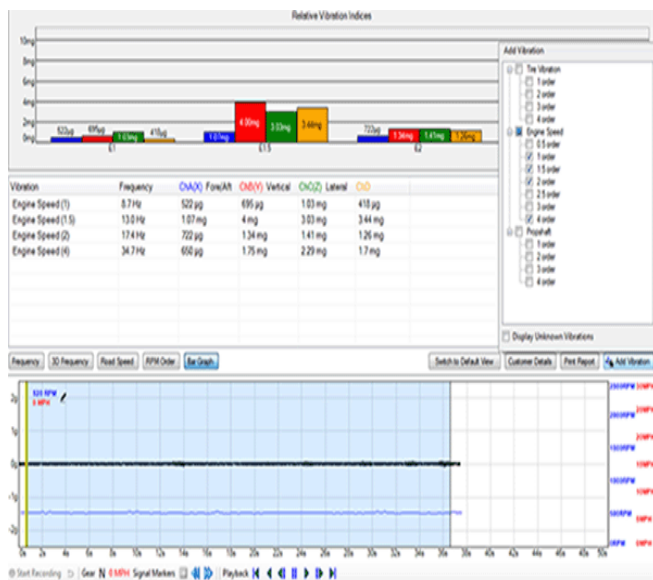

4534309

Note: Amplitude (mg) readings from a single-axis pico sensor will be approximately 10% lower than with a tri-axis sensor. For example a reading of 4 mg using a tri-axis sensor, would likely measure as about 3.6 mg on a single-axis sensor.

If the disturbance frequency measures at the seat track as E1.5 with amplitude of approximately 2 mg or higher using a tri-axis sensor, continue with steps in this bulletin to reduce the amplitude (mg) of the disturbance, then exercise the vehicle and re-measure using pico to determine level of improvement.

If the E1.5 disturbance measures approximately 2 mg or lower using the Pico tri-axis sensor as indicated – the vehicle is considered acceptable.

1. Place tri-axis pico sensor on the inboard seat track forward-most location to record measurement of the rough idle vibration concern.

Note: Most rough idle in Drive concerns are temperature dependent and can be difficult to re-create at times.

2. With A/C On, perform several short heavy launch events from stop to stop to bring the temperatures back up while attempting to re-create the rough idle vibration in Drive with Pico sensor placed on inboard seat track; while the vibration is active – Record Pico reading. This method seems to provide better results than extended test drives.
3. If the Pico reading for E1.5, with vibration active, at the inboard forward seat track location measures approximately 2 mg or higher – continue following steps in this bulletin to **install updated engine mounts and perform the engine/trans mount settling process.**
4. If the Pico reading for E1.5, with vibration active, at specified seat track location measures close to 2 mg or less – investigate other sources of the rough idle / vibration concern using SI diagnostics.

Install Updated Engine Mounts and Engine/ Trans Mount Settling Process

For Vehicles Built Prior to:

SUV - February 2, 2017

V-6 PU - March 15, 2017

V-8 PU - March 22, 2017

Note: For any engine mount to frame bolts and engine mount to engine block bolts removed during this process – clean bolt threads using denatured alcohol or equivalent; then apply threadlocker or equivalent to the bolt threads. Refer to Adhesives, Fluids, Lubricants, and Sealers.

Important: Do Not use Impact wrenches when tightening the engine mount to frame bolts, or damage to threads in the frame may result.

Important: Both LH and RH engine mounts need to be seated to the vehicle frame **At The Same Time** to help ensure best alignment.

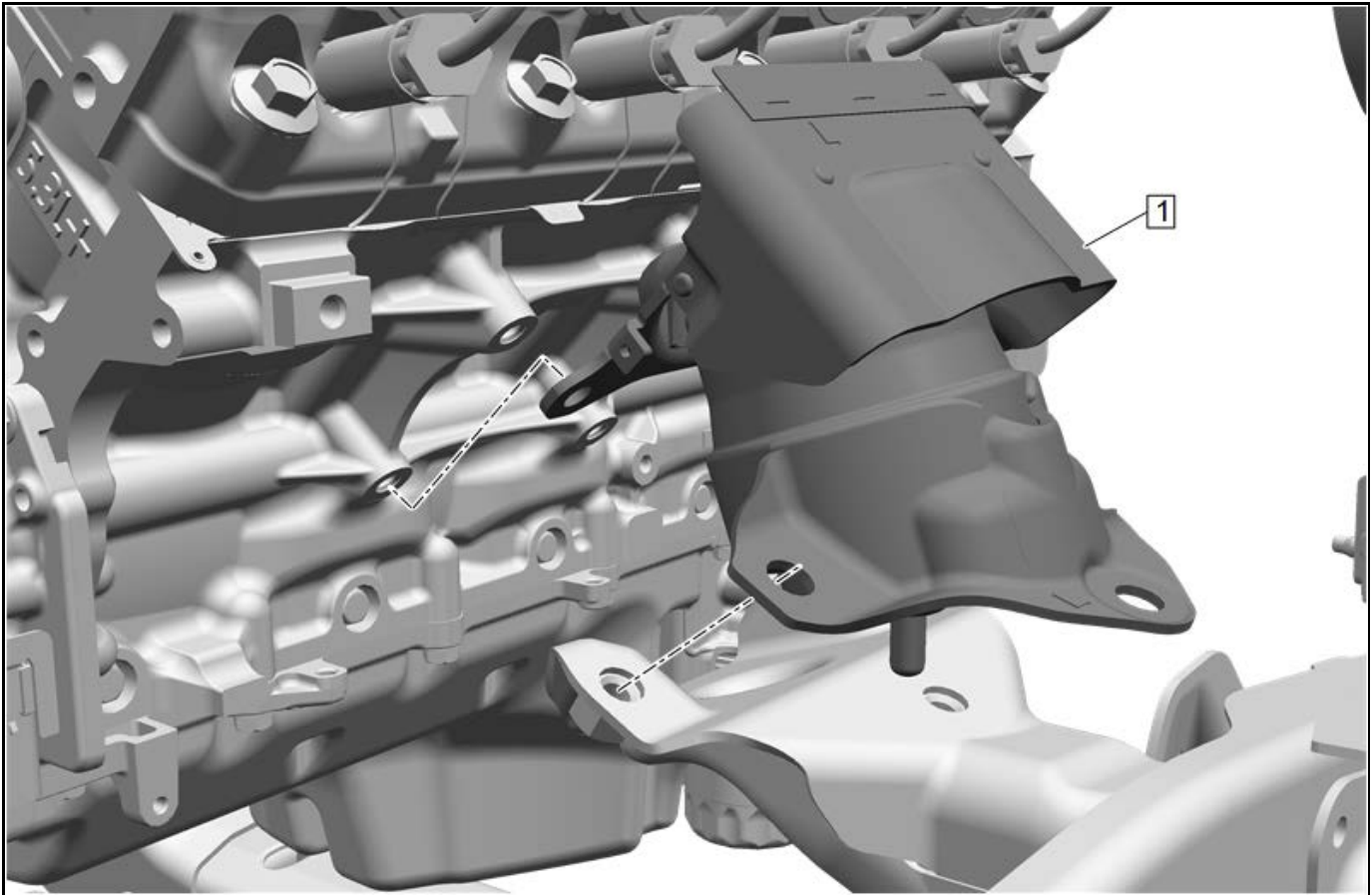

5030893

Summarized below are key notes for engine mount replacement for rough idle:

1. Replace both engine mounts (1). Refer to Engine Mount Replacement – Left and Right Engine Mount Replacement in SI.
2. Install but do **NOT** tighten the mount to frame bolts.
3. Settle all mounts as follows:
 - 3.1. Ensure the engine mount to frame bolts on both LH and RH sides are loosened a couple turns.
 - 3.2. Ensure, the transmission/transfer case mount to frame crossmember nuts are loosened a couple of turns.
 - 3.3. Have assistant set park brake and apply base brake.
 - 3.4. Have assistant turn Traction Control Off, and brake torque in Drive and Reverse with the engine at operating temperature, then place in Neutral and turn engine Off.

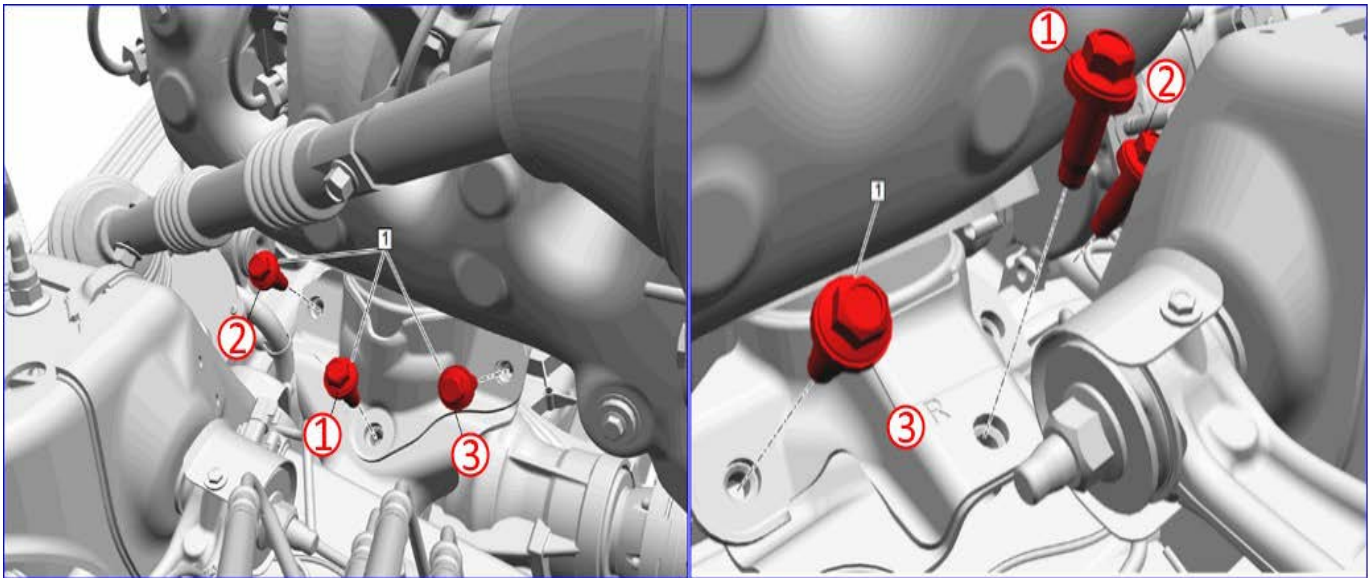

5318277

3.5. In Neutral, with engine Off, using Only Hand Tools, torque all engine mount to frame bolts (1) in sequence shown;

3.5.1. **50 Nm (37 lb ft)**

3.5.2. **Final Pass 65 degrees**

3.6. Torque the transmission/transfer case mount to crossmember nuts to 55 Nm (41 lb ft).

4. Re-evaluate the rough idle vibration – repeating steps 1-4 under Initial Set-up / Duplication / Evaluation.

If the E1.5 idle vibration at inboard seat track forward location has been reduced to 2 mg or less – the vehicle is considered acceptable.

If a different frequency other than E1.5 is now elevated, for example E4, then most likely one of the mounts is bound. Carefully repeat the mount settling process for the engine and trans mounts, then re-evaluate.

Shimming Procedure for Engine Mount Vibration/Grounding after Mount Replacement

For Vehicles Built After to:

SUV - February 2, 2017

V-6 PU - March 15, 2017

V-8 PU - March 22, 2017

Important: For any engine mount to frame bolts removed during this process. Clean bolt threads using denatured alcohol or equivalent; then apply threadlocker or equivalent to the bolt threads. Refer to Adhesives, Fluids, Lubricants, and Sealers. Important.

Note: Idle vibration caused by ground-out within an engine mount may be able to be turned off/on with a single bolt location. Shimming that bolt location may greatly reduce the vibration. In some cases, a combination of bolt location shimming may be needed.

1. With the aid of an assistant, run vehicle in stall with the parking brake set and base brake applied, in Drive, monitoring E1.5 on Pico at inboard seat track, with idle vibration active, perform the following:

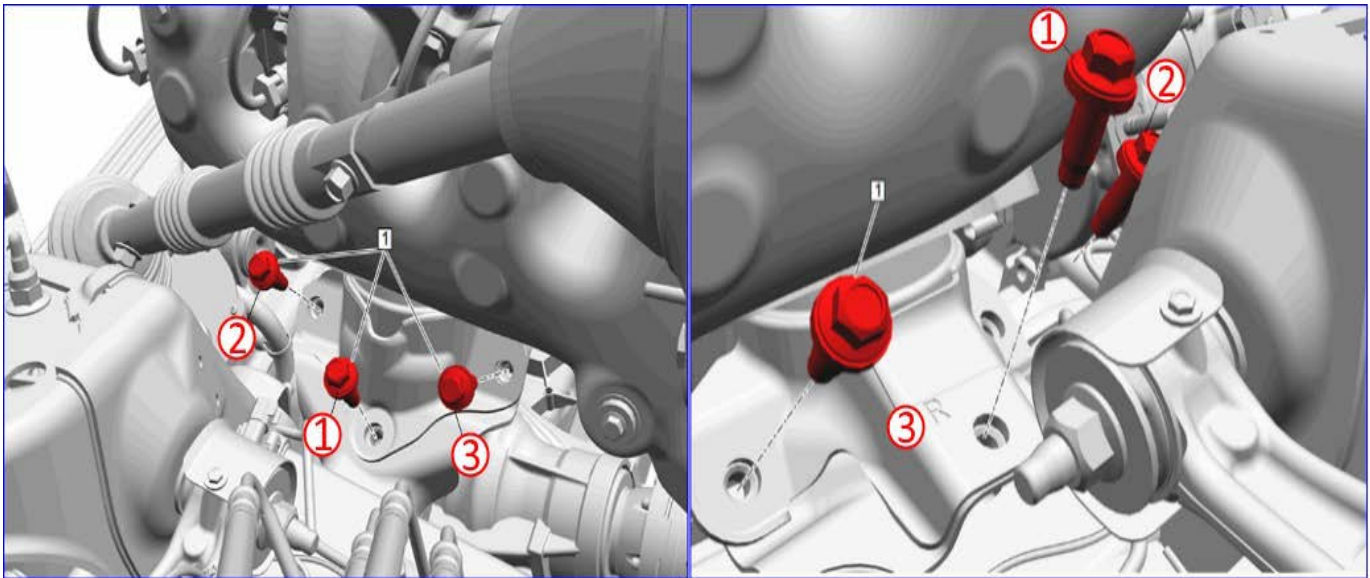

5318277

Important: Do Not use Impact wrenches when tightening the engine mount to frame bolts, or damage to threads in the frame may result.

2. Beginning with RH side, loosen the engine mount to frame bolts one at a time a few turns to release clamp load beginning with rear bolt at position 6, front bolt at position 5 and the middle bolt at position 4.
 - ⇒ Verify if idle vibration was significantly reduced or eliminated when the bolts were loosened.
3. Torque bolts to specifications in order and validate if the vibration returns.
4. Repeat the process on the LH mount starting at the rear bolt at position 3, front bolt at position 2 and the middle bolt at position 1.
 - If idle vibration **Does Not** return when the RH or LH engine mount bolts are re-torqued to specifications, no further work is required.
 - If idle vibration **Does** return, proceed with procedure.

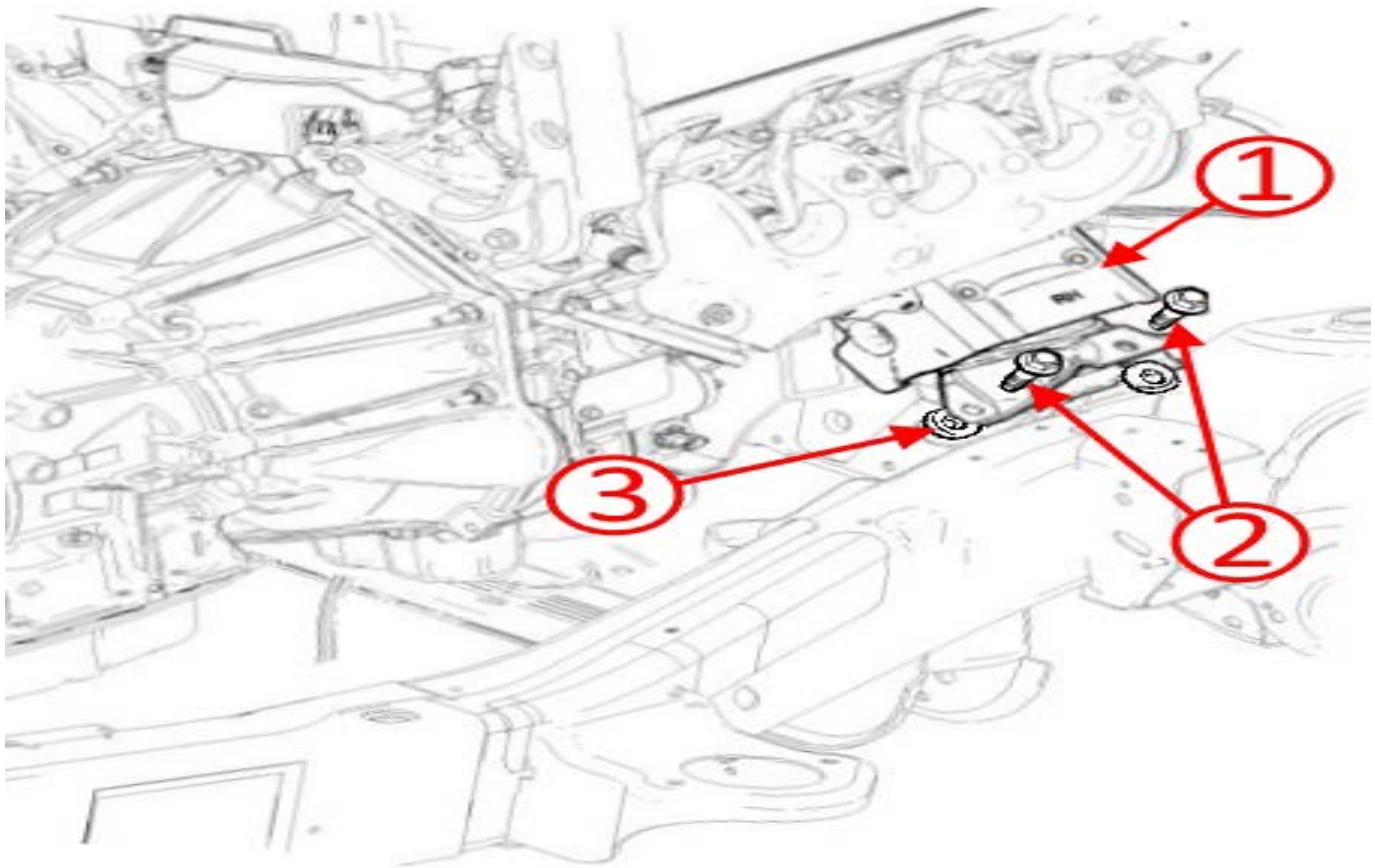

5164611

Note: Pause after loosening any of the mount bolts during these steps to determine the effect of the idle vibration on the Pico, at the seat track while making note of effect from each bolt location.

5. Beginning with RH side, loosen the engine mount (1) to frame bolts one at a time a few turns to release clamp load.
6. Remove the position 5 and 6 bolts (2),
7. Utilizing a jack with a block of wood, carefully raise the engine.

Note: For spacer washers mild steel is recommended, no stainless; it may be necessary for some locations to use a small amount of adhesive such as 'dum-dum' to hold spacer in place.

8. If idle vibration was significantly reduced, add a spacer washer (3) approximately 2.5 mm thick between the engine mount and frame at position 5 and 6.
9. Apply threadlocker or equivalent to the threads of the engine mount to frame bolts. Refer to Adhesives, Fluids, Lubricants, and Sealers.
10. Lower the engine.
11. Torque the bolts to specifications to validate if the vibration returns:
 - If idle vibration **could** be turned off with shimming one side, no further work is required.
 - If idle vibration returns. Remove the shims and repeat the process for the LH mount.

12. Tighten the affected engine mount to frame bolts in sequence, to specification.

Re-evaluate the rough idle vibration by repeating steps 6-9 under **Initial Setup / Duplication / Evaluation**.

- ⇒ If the E1.5 idle vibration at inboard seat track forward location has been reduced to less than 3 mg, determine with customer if condition is now acceptable.

If there was not a single bolt location on the RH or LH mount which could turn the idle vibration off/on, shimming will be necessary for 2 or 3 bolt locations on one side.

- ⇒ Go back to the 2 bolts with greatest effect recorded on vibration reduction on one side and shim those bolts.

Fine Tuning - Pico Sensor on Mounts (If Needed)

Note: It is difficult to lower amplitude of E1.5 idle vibration at the seat track to about 2.5 mg or lower. Many customers are satisfied with approximately 3 mg or less. Some customers may not be satisfied until the idle vibration is brought below 3 mg, closer to 2.5 mg.

1. While the tri-axis sensor is mounted on the inboard seat track forward most location (Channels A-C), Add a second Pico sensor tri-axis or single plane using Channel D.
2. Place the added Pico sensor on the middle engine mount bolt head, beginning with RH side.

3. For Pico readings from the mount, focus on Vertical E1.5. (suggest removing lateral and fore/aft channels from display, and removing E1 and E4 from display).
4. While the idle vibration is active, record the E1.5 amplitude (mg).
5. Repeat steps 1-4 for LH side while the idle vibration is active, and compare readings.
6. Focusing on the side with highest E1.5 amplitude (mg), perform the following:
 - 6.1. Place the added Pico sensor on the engine mount rear bolt head.
 - 6.2. While the idle vibration is active, record the E1.5 amplitude (mg).
 - 6.3. Move sensor to middle bolt head and repeat.
 - 6.4. Move sensor to front bolt head and repeat.

⇒ if a spacer washer is not already in position, add a spacer washer approximately 2.5 mm thick between the engine mount and frame attachment at the bolt location with the highest recorded E1.5 amplitude (mg).
7. Re-evaluate the rough idle vibration repeating steps 1-4 under Initial Setup / Duplication / Evaluation:
 - If the E1.5 idle vibration at inboard seat track forward location has been reduced below 3 mg, determine with customer if condition is now acceptable.
 - If the E1.5 idle vibration at inboard seat track forward location has not been reduced below 3 mg, if a spacer washer is not already in position, add a spacer washer, approximately 2.5 mm thick between the engine mount and frame attachment at the bolt location with the second highest recorded E1.5 amplitude (mg). (Leave the spacer washer at the highest recorded bolt location.)
8. Re-evaluate the rough idle vibration by repeating steps 1-4 under Initial Setup / Duplication / Evaluation.

Parts Information

Causal Part	Description	Part Number	Qty
X	Mount, Engine	Refer to EPC	1 Set

Warranty Information

For vehicles repaired under the Powertrain coverage, use the following labor operation. Reference the Applicable Warranties section of Investigate Vehicle History (IVH) for coverage information.

Labor Operation	Description	Labor Time
4081688*	Perform Pico Scope Idle Vibration Measurement	0.4 hr
4086928*	Engine Mount Shimming Procedure - One Side Note: Time Includes Engine and Trans Mount Settling.	1.5 hr
Add	Engine Mount Shimming Procedure - Both Sides	0.5 hr
4081348*	Engine Mount Replacement - Both Sides	3.8 hr (SUV)
		3.1 hr (PU V-6)
		3.2 hr (PU V-8)
*This is a unique Labor Operation for Bulletin use only.		

Version	5
Modified	<p>Revised June 6, 2017 - Updated information, moved Parts Information and Warranty Information tables to bottom of bulletin and added Keywords.</p> <p>Revised September 05, 2018 - Updated labor time information</p> <p>Revised November 16, 2018 - Add Mount Shimming Procedure and Fine Tuning sections, Added 2018 Model Year and Removed Vin Break Point.</p> <p>Revised April 18, 2019 - Update Shimming Procedure section, Add build cutoff dates, Update Engine Mount procedure, Updated Parts Information section and update the labor time.</p>

Additional Keywords: PIP5211, PIP5211D, PIP5211E, vibration

