

REFERENCE:	Nova Bus Manuals
SECTION:	07: Steering Mechanism
RS N°:	MQR 7621-1316
EFFECTIVE IN PROD.:	L948 (2016DE)

APPLICATION DEADLINE: 2021JU09
CLAIM REFERENCE NUMBER: WB-4355

SUBJECT:	Drag link tightening collar
JUSTIFICATION:	Improper collar installation may cause interference between adjacent parts.

LEVEL	DESCRIPTION	DIRECT CHARGES		TIME
		LABOUR	MATERIAL	
1	Inspect and adjust the orientation of the tightening collar if necessary.	Nova Bus	Nova Bus	10 min
2	If there has been interference with the collar or the drag link, replace the drag link.	Nova Bus	Nova Bus	1h30

MATERIAL

QTY	PART N°	REV.	DESCRIPTION	REPLACES PART N°
LEVEL 1				
–	–	–	–	–
LEVEL 2 (only if required*)				
1	N10379	D	Drag link	–
2	N20644	–	Cotter pin	–

Materials will be available within 57 days. To order, please contact Prevost Parts by phone at 1-800-771-6682, by fax at 1-888-668-2555 or by email at prevostparts.commandes@volvo.com. Specify document number, quantity of parts required and shipping address.

DISPOSAL OF PARTS

REMOVED PARTS ARE:	DISCARDED *	RETAINED	* Dispose of the unused parts and the defective parts in accordance with local environmental standards in effect.
	Yes	–	

REVISION HISTORY

REV.	DATE	CHANGE DESCRIPTION	WRITTEN BY
NR	2019AL09	Initial release	André Pelletier

CLIENT	ORDER	ROAD NUMBER		VIN (2NVY/4RKY...)		QTY
		FROM	TO	FROM	TO	
Ames Transportation Agency - Iowa	L904	6101	6104	S92J1G9775221	S92J7G9775224	4
Barrie Ontario - Metrolinx	L955	1601	1604	L82J7G9775408	L82J9G9775412	4
Bow Valley Transit - Alberta	L993	—	—	L82JXG3750329	L82J6G3750330	2
Brampton - Ontario	L941	1614	1623	L82J1G3750123	L82J2G3750132	10
Brampton - Ontario	L942	1601	1613	L82J6G3750070	L82J4G3750083	13
Brandon - Manitoba	L899	67	70	L82J2G3750180	L82J8G3750183	4
Brantford - Ontario	LA03	10161	10612	L82J0G3750369	L82J7G3750370	2
Chicago Transit Authority - CTA - Illinois	L943	8200	8324	L82JXG9775225	L82J3G9775406	125
Démo US	LA13	—	—	L82J4G9775611	L82J5G9775620	10
Démo-2017	L980	—	—	L82J1G9775565	L82J9G9775569	3
Duke University - North Carolina	L938	—	—	L82L8G9775399	L82L0G9775400	2
Durham Region Transit Ontario - Metrolinx	L996	8560	8563	L82J1G3750414	L82J7G3750417	4
Durham Region Transit Ontario - Metrolinx	LA19	8564	8565	L82J9G3750418	L82J0G3750419	2
Fredericton - New Brunswick	L968	8161	8162	L82J1G3750218	L82J3G3750219	2
Guelph - Ontario	L985	248	251	L82J7G3750255	L82J2G3750258	4
Halifax - Nova Scotia	LA11	1208	1236	L82J1G9775579	L82J4G9775608	29
Halifax - Nova Scotia	LA14	1237	1237	L82J1G9775596	L82J1G9775596	1
Hamilton - Ontario - Metrolinx	L956	1601	1632	L82K2G9775325	L82K3G9775415	32
Hamilton - Ontario - Metrolinx	LA05	1633	1643	L82K4G9775553	L82K7G9775577	11
Houston - Texas	L951	1915	1915	L82J0G9775203	L82J0G9775203	1
Houston - Texas	L952	1580	1580	S92J5G9775318	S92J5G9775318	1
Houston - Texas	L981	1916	1994	L82J8G9775434	L82J4G9775513	79
Houston - Texas	L982	1581	1599	S92J5G9775514	S92J5G9775545	19
Kingston - Ontario Metrolinx	L889	1687	1689	L82J1G3750252	L82J5G3750254	3
Kingston - Ontario Metrolinx	L954	1683	1686	L82J4G3750259	L82J4G3750262	4
Lethbridge - Alberta	L997	181	186	L82J5G9775570	L82JXG9775578	6
Milton - Ontario - Metrolinx	L884	1701	1702	L82J0G3750338	L82J2G3750339	2
Moncton (Codiac) - New Brunswick	LA06	—	—	L82J3G9775552	L82JXG9775564	9
New York City Transit - New York	L844	8381	8170	L82J0G9775024	L82J0G9775105	82
New York City Transit - New York	L845	8171	8480	L82J2G9775106	L82J6G9775187	82
New York City Transit - New York	L958	5439	5442	S92J9G9775533	S92J9G9775631	4
NFTA - Buffalo, New York	L947	1601	1624	L82KXG9775248	L82K3G9775320	24
Niagara Falls - Ontario	L987	1601	1604	L82J6G3750344	L82J1G3750347	4
North Bay - Ontario	L979	786	787	L82J4G3750312	L82J6G3750313	2
Oakville Ontario - Metrolinx	L945	—	—	L82J9G3750211	L82JXG3750217	7
Orillia Ontario - Metrolinx	L965	1722	1724	L82J3G3750320	L82J7G3750322	3
Peterborough - Ontario	L966	67	71	L82J2G3750230	L82JXG3750234	5
Red Deer - Alberta	L924	10104	10147	L82K0G9775517	L82KXG9775542	12
Red Deer - Alberta	L960	10021	10025	L82K9G9775418	L82K3G9775429	5
Regina - Saskatchewan	L949	692	696	L82J3G3750205	L82J0G3750209	5
Regina - Saskatchewan	L992	—	—	L82J6G3750294	L82J3G3750298	5
San Antonio Texas	L990	—	—	L82K5G9775464	L82K5G9775464	1
San Antonio Texas	LA10	422	446	L82K9G9775628	L82K8G9775653	25

CLIENT	ORDER	ROAD NUMBER		VIN (2NVY/4RKY...)		QTY
		FROM	TO	FROM	TO	
San Antonio Texas	LA22	447	555	L82K8H9775654	L82K0H9775762	109
Sarnia Ontario	L963	162	162	L82J7G3750305	L82J7G3750305	1
Saskatoon - Saskatchewan	L953	1601	1610	L82J9G3750158	L82JXG3750167	10
Sault Ste. Marie Ontario	L934	—	—	L82JXG3750038	L82JXG3750038	1
SEPTA - Pennsylvania	L861	7300	7484	S92L5G9775188	S92L8G9775220	32
St. Catharines Ontario - Metrolinx	L882	1601	1605	L82J9G3750225	L82J9G3750229	5
St. John - New Brunswick	L939	40687	40687	L82J0G3750078	L82J0G3750078	1
Sudbury - Ontario	L994	861	865	L82J1G3750364	L82J9G3750368	5
Thunder Bay Ontario - Metrolinx	L944	—	—	L82J6G3750084	L82JXG3750086	3
Thunder Bay Ontario - Metrolinx	LA01	—	—	L82J5H3750448	L82J7H3750449	2
Timmins - Ontario	L995	—	—	L82JXG3750377	L82JXG3750377	1
University of Alabama - Alabama	L961	7032	7033	L82J7G9775294	L82J9G9775295	2
University of Alabama - Alabama	LA02	7034	7037	L82J8G9775546	L82JXG9775550	4
Welland Ontario - Metrolinx	L991	—	—	L82J9G3750287	L82J9G3750287	1
Whitehorse - Yukon	LA04	—	—	L82J2G3750390	L82J4G3750391	2
York Regional Transit - Ontario	L964	1770	1774	S92J6G3750420	S92J3G3750424	5
York Regional Transit - Ontario	L967	1601	1621	L82J2G9775414	L82J8G9775627	21
York Regional Transit - Ontario	LA07	1701	1715	L82J9G3750340	L82JXG3750363	15

**WARNING**

FOLLOW YOUR INTERNAL SAFETY PROCEDURES.

PROCEDURE

LEVEL 1: INSPECT

- 1.1. Raise the vehicle.

**CAUTION**

For more information on the raising and lowering of the vehicle, refer to SECTION 18: HOISTING AND TOWING of the Nova LFS maintenance manual. Respect your current internal safety procedures. Use the proper hoisting equipment for your safety.

- 1.2. Locate the drag link tightening collar of the drag link located between the front wheels. See Figure 1.

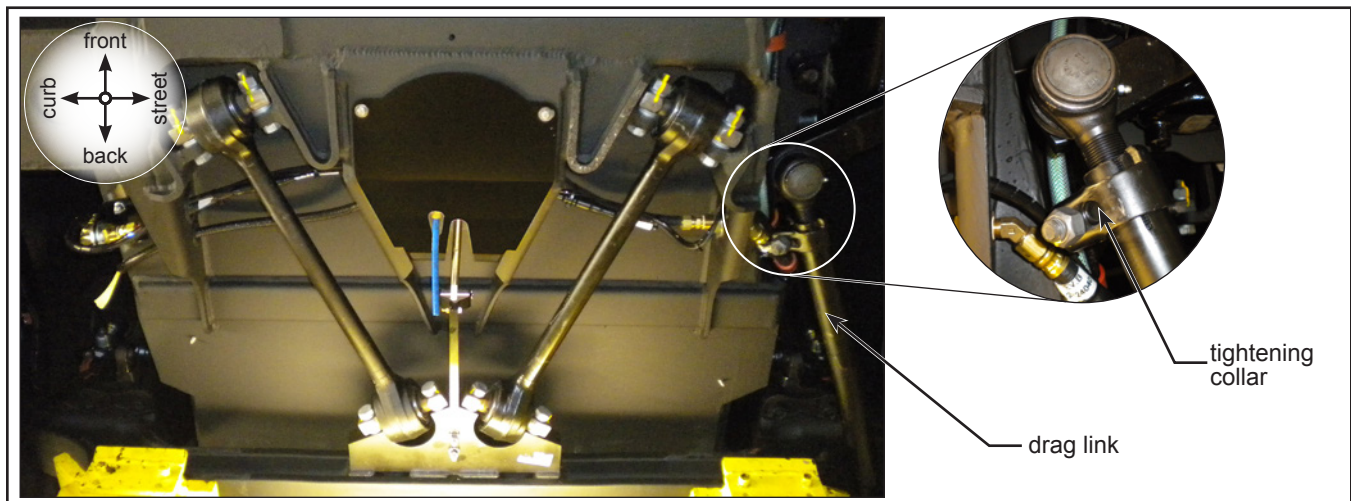

*Figure 1 - Steering Mechanism Drag Link
(As Seen From Below the Vehicle)*

- 1.3. Verify the orientation of the tightening collar. The tightening collar is correctly installed when the axis of the bolt is positioned at a 45° angle from the vertical. See Figure 2.
- 1.4. If the bolt axis is correctly oriented at 45°, no action is needed. The vehicle can be lowered and put back into service.

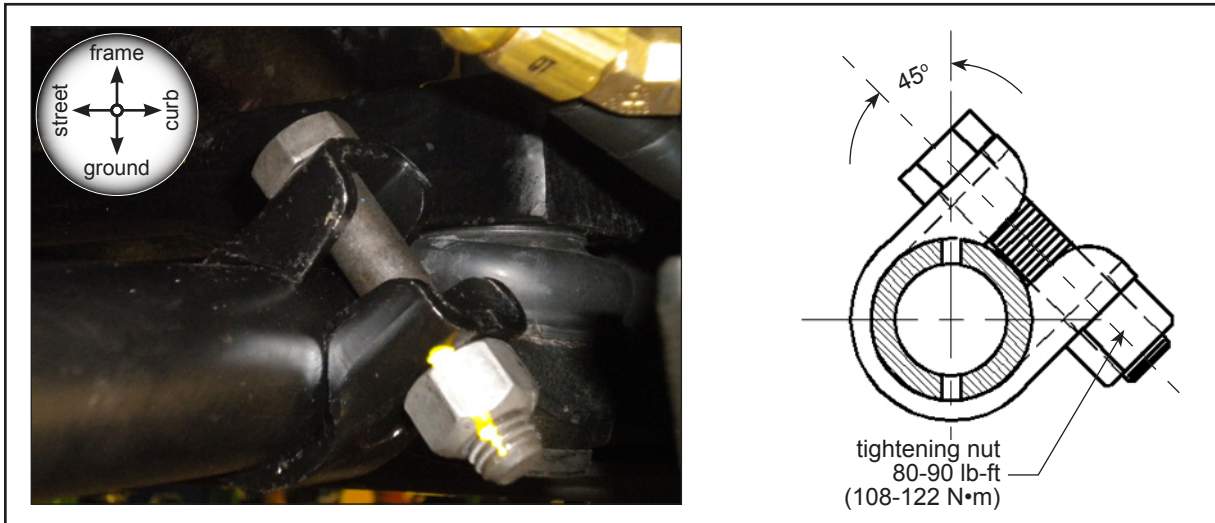

Figure 2 - Correct Installation of the Tightening Collar

- 1.5. If there has been interference with the collar or the drag link, go to LEVEL 2: DRAG LINK REPLACEMENT.
- 1.6. If the collar is not at 45°, loosen the nut and turn the collar around the rod until the bolt axis is correctly aligned. See Figure 2.
- 1.7. Torque the nut to 80-90 lb-ft (108-122 N·m). See Figure 2.
- 1.8. The vehicle can be lowered and put back in service.

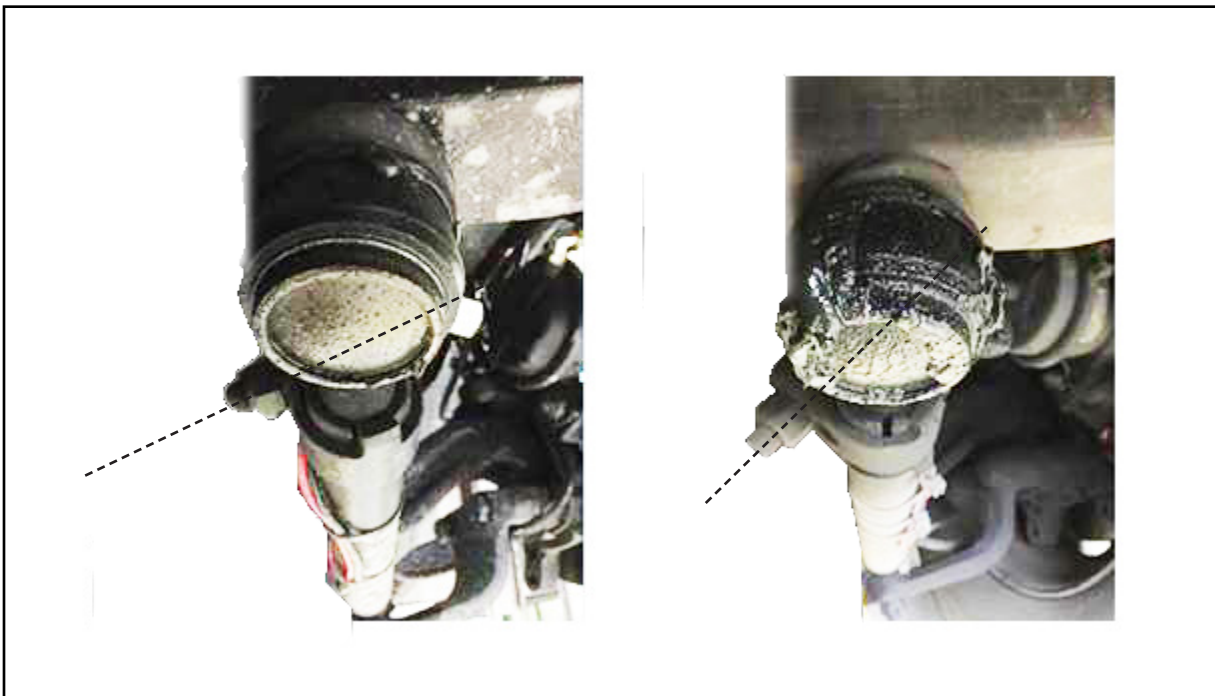

Figure 3 - Before and After Correction

LEVEL 2: DRAG LINK REPLACEMENT

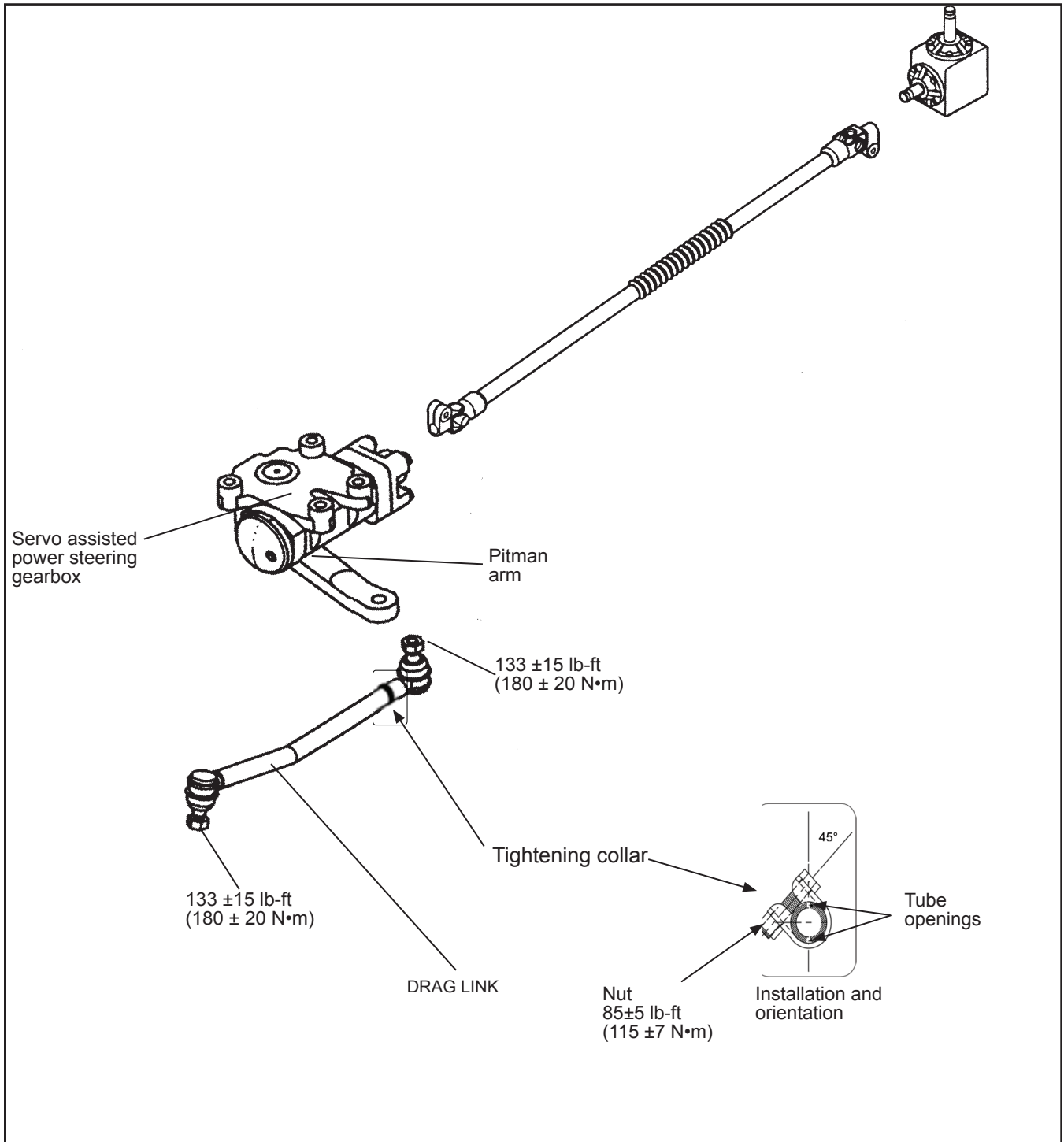

Figure 4 - Couples pour la tige d'entraînement

**REMARQUE**

Consult your service manual **SECTION 07: STEERING MECHANISM** for more details.

- 2.1. Detach the ends of the drag link by removing the cotter pins and the castle nuts.
- 2.2. Remove the drag link and transfer the grease fittings (manual or automatic) to the new drag link. See Figure 5.

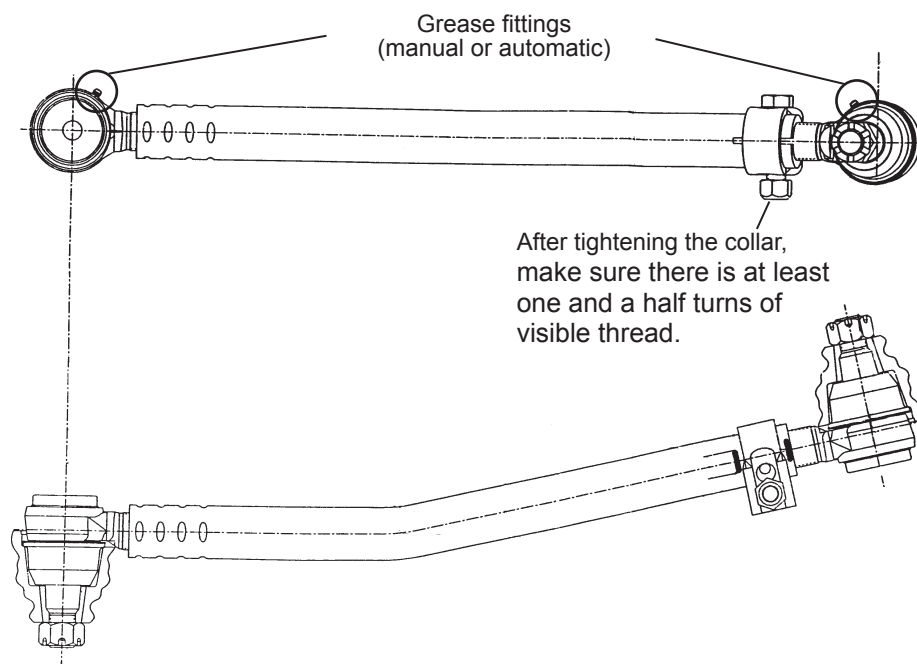

Figure 5 - Drag Link

- 2.3. Place the front wheels in a straight-ahead position.
- 2.4. Determine the steering movement center by turning the steering wheel from extreme right to extreme left and counting the number of revolutions. Turn in the opposite direction by exactly half the number of revolutions.
- 2.5. Check the pitman arm position. See Figure 4 and see SECTION 07: STEERING MECHANISM in your manual.
- 2.6. Screw the drag link ends in the tube without torquing. Make sure both ends are equally screwed into the tube.
- 2.7. Set the drag link into position on the vehicle and install the balls to the steering and pitman arm using slotted nuts.
- 2.8. Adjust the drag link by turning the tube until a length of 26.81 in (68.09 cm) is reached between the center of the steering arm ball and the center of the pitman arm ball.
- 2.9. Position the collar so that the axis of the nut is at an angle of 45° relative to the tube opening. Torque the clamping collar bolt until the torque value indicated in Figure 4 is reached. And make sure there is at least one and a half turns of visible thread. See Figure 5.
- 2.10. Check the adjustment. The front wheels should be able to turn from extreme right to extreme left without the drag link ends blocking. Tighten the slotted nuts to the appropriate torque value. See Figure 4.
- 2.11. If necessary move the slotted nuts to the next insertion slot. Install a new cotter pin.
- 2.12. Lubricate the ends of the drag link manual grease fittings with lithium grease as instructed in SECTION 19: PREVENTIVE MAINTENANCE of Your Manual.
- 2.13. Check the front wheels alignment, see SECTION 04: AXLE ALIGNMENT in your manual.
- 2.14. The vehicle can return in service.

