

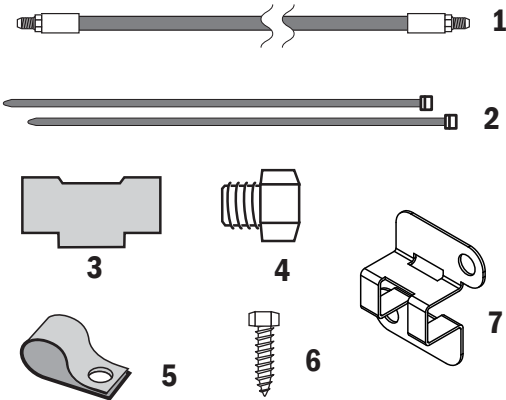

INSTALLATION INSTRUCTIONS

Hydraulic Brake Line Kits



| # | Single K71-G02-57 (80327) | Single K71-G02-58 (80326) | Tandem K71-G02-59 (80328) | TDE Part # | DX Part # | Description |
|---|---------------------------------|---------------------------------|---------------------------------|------------|------------|--------------------|
| 1 | 2 | 2 | 4 | 46238-24 | 034-5A0-24 | Flex Hose 24" |
| 1 | 1 | 0 | 1 | 46238-38 | 034-5A0-38 | Flex Hose 38" |
| 1 | 1 | 1 | 2 | 46238-76 | 034-5A0-76 | Flex Hose 76" |
| 1 | 0 | 1 | 1 | 46238-240 | 034-5A2-40 | Flex Hose 240" |
| 2 | 4 | 5 | 9 | 10107 | 027-092-00 | Cable Ties |
| 3 | 2 | 2 | 4 | 11270 | 034-412-00 | Union "T" |
| 4 | 1 | 1 | 1 | 10128 | 034-410-00 | Union "T" Plug |
| 5 | 2 | 4 | 6 | 17003 | 027-096-00 | Cable Clamps |
| 6 | 6 | 8 | 14 | 10589 | 007-634-00 | Self Taping Screws |
| 7 | 2 | 2 | 4 | 42091 | 071-G03-00 | "T" Clamp |

Read all of the instructions first and familiarize yourself with the parts and layout before starting the installation. Make sure your actuator is in good working condition, and that it is the proper model for your drum or disc brakes.

- Attach one end of the 48 inch long flex hose into end of the T-block. Route the flexible flex hose down the frame and to the center of the second axle. If the hose is too long, DO NOT CUT ANY BRAKE LINE or HOSE, THE FITTINGS CANNOT BE REATTACHED. Instead, coil the flex hose at or near the axle line and secure the loop with a cable tie. Secure the hose to the trailer frame with the C-clamps and self-taping screws provided. NEVER CUT ANY BRAKE LINE HOSE!! It cannot be patched or flared, and comply with D.O.T. approved systems. Use only factory completed hose sections.
- Next, install a three-way brass adapter fitting to the end of the flex hose at the axle line. Attach the three-way fitting to the side of the trailer frame using the stainless "T" bracket provided. Attach to the frame using the self-tapping screws or a cable tie provided.
- Connect a 24" flex hose to the middle position on the "T" fitting. Plug the end or third hole in the "T" fitting with the 3/8" plug provided. Connect the 2nd 24" flexible hose to the left brake (closest to your main brake line). Connect the 76" flex hose to the right side brake. Determine a position on the axle where the three flex hoses come together allowing free movement at the axle or brake. Connect the three hoses to a "T" fitting. Attach the "T" fitting to the axle using the "T" bracket provided with the self-taping screws or a cable tie.
- Tighten all connections to about 3 ft pounds using a 3/8" open end wrench.
- Secure the Flex hoses to the frame and axle

using the C-clamps and cable ties provided.

- Fill your actuator with DOT 3 brake fluid and follow your actuator/ brake's instructions on bleeding the system. Check all connections for leaks. Tighten as required.
- After completing the installation, bleed the brakes using instructions from your actuator manufacturer and test the brakes in an area where you will not upset normal traffic flow. Recheck all connections for leaks. Check again after the first 25 miles.
- For Tandem Axle:** follow all the installation instructions from the Single Axle Brake Line Kit, except for the installation of the 3/8" plug that is used in the 3rd "hole" of the frame mounted T-block.

NOTE: Use DOT 3 brake fluid. Use of any other brake fluid may damage seals and voids the warranty.

All images in this instruction sheet are for illustrative purposes only. Your kit may vary depending on options.

Assembly Diagram

