

Keystone RV Company

4/16/19

SERVICE ADVISORY # 19-350

Coleman Slide Out Refrigerator

It has been determined that certain Dutchmen Coleman models with Dometic Refrigerators installed in the slide out do not have a ventilation fan installed. The following procedure describes how to install the ventilation fan.

Models Included:	2019 Coleman Travel Trailers
Models:	2425RB, 2825RK
Serial Number Range:	KM933057 – KM939434
Parts Required:	1 – KRV # 588188 - Refrigerator - Fan Only - For 6/8Cu
Tools Required:	- Screw gun - 5/8" wrench -13/16"wrench

Note – Check serial number on Key Express to verify the campaign is open. Some vehicles were repaired before they left Keystone.

When performing warranty or recall service, please make certain that appropriate Personal Protective Equipment (PPE) is used.

REPAIR INSTRUCTIONS

Step 1

Locate the trailer on a level, flat, hard surface. Chock the wheels.

Step 2

Disconnect 120-volt power and 12-volt.

Step 3

On the main floor use a protective covering to prevent damage. Remove refrigerator using industry standards and sit refrigerator on main floor to access rear of appliance.

Step 4

Using the following Dometic instructions, install the ventilation fan.

Power Ventilator Assembly

Model 3316331.000

For 6 & 8 Cu. Ft. Models

DOCUMENT SYMBOLS	1
IMPORTANT SAFETY INSTRUCTIONS	2
A. Recognize Safety Information	2
B. Understand Signal Words	2
C. Supplemental Directives	2
D. General Safety Messages	2
GENERAL INFORMATION	2
INSTALLATION	3
A. Mounting The Fan Bracket	3
B. Mounting The Thermal Switch	3
C. Connecting The Wire Assembly	3
D. Connecting The Fan Wires	4
E. Applying The Wiring Decal	4

DOCUMENT SYMBOLS

 Indicates additional information that is not related to physical injury.

 **Read these instructions carefully. These instructions MUST stay with this product.**
Dometic Corporation reserves the right to modify product appearances and specifications without notice.

REVISION A
Form No. 3316329.000 02/17
(French 3316330.000_A)
©2017 Dometic Corporation
LaGrange, IN 46761

USA
SERVICE OFFICE
Dometic Corporation
1120 North Main Street
Elkhart, IN 46514

CANADA
Dometic Corporation
46 Zatonski, Unit 3
Brantford, ON N3T 5L8
CANADA

SERVICE CENTER & DEALER LOCATIONS
Visit:
www.eDometic.com

IMPORTANT SAFETY INSTRUCTIONS

This manual has safety information and instructions to help you eliminate or reduce the risk of accidents and injuries.

A. Recognize Safety Information

 This is the safety alert symbol. It is used to alert you to potential physical injury hazards. Obey all safety messages that follow this symbol to avoid possible injury or death.

B. Understand Signal Words

A signal word will identify safety messages and property damage messages, and will indicate the degree or level of hazard seriousness.

WARNING indicates a hazardous situation that, if **NOT** avoided, could result in death or serious injury.

CAUTION indicates a hazardous situation that, if **NOT** avoided, could result in minor or moderate injury.

NOTICE is used to address practices **NOT** related to physical injury.

C. Supplemental Directives

 Read and follow all safety information and instructions to avoid possible injury or death. Read and understand these instructions before [installation / use / service / maintenance of] this product. Incorrect [installation / operation / service / maintenance] of this product can lead to serious injury. The installation **MUST** comply with all applicable local or national codes, including the latest edition of the following standards:

U.S.A.

- ANSI/NFPA70, National Electrical Code (NEC)
- ANSI/NFPA 1192, Recreational Vehicles Code
- Title 24 CFR, Part 3280, Manufactured Home Construction and Safety Standard
- National Fuel Gas Code, ANSI Z223.1/NFPA 54

CANADA

- CSA C22.1, Parts I & II, Canadian Electrical Code
- CSA Z240 RV Series, Recreational Vehicles
- CSA Z240.4, Gas-Equipped Recreational Vehicles and Mobile Housing
- CSA B149.1, Natural Gas and Propane Installation Code

D. General Safety Messages

WARNING Failure to obey the following warnings could result in death or serious injury:

- This product **MUST** be [installed / serviced] by a qualified service technician.
- Do **NOT** modify this product beyond the scope of these service instructions. Modification (beyond these service instructions) can be extremely hazardous.

GENERAL INFORMATION

INCLUDED HARDWARE	
(1) 385118301 Fan, 12 VDC	(2) 385808901 Screw, EML, 5 x 10 mm
(1) 385139001 Fan Bracket	(1) 385801902 Cable Tie
(1) 385030606 Thermal Switch, Fan	(1) 295459901 Wire Assembly
(1) 385008502 Fused Wire Assembly, 3A	(2) 385800214 Screw, RXS, 3.5 x 9.5 mm
(2) 385800220 Screw, RXS, 4.2 x 9.5 mm	(1) 3105433.001 Wiring Decal, Fan

INSTALLATION

A. Mounting The Fan Bracket

NOTICE Disconnect the positive (+) 12 Vdc terminal from supply battery. Otherwise, damage to unit could occur.

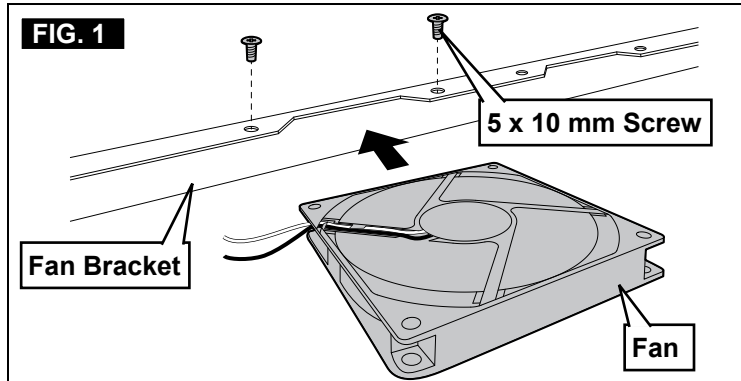

1. Mount the fan to the fan bracket along the left set of holes using the 5 x 10 mm screws. In this position, the fan blows air in an upward direction.

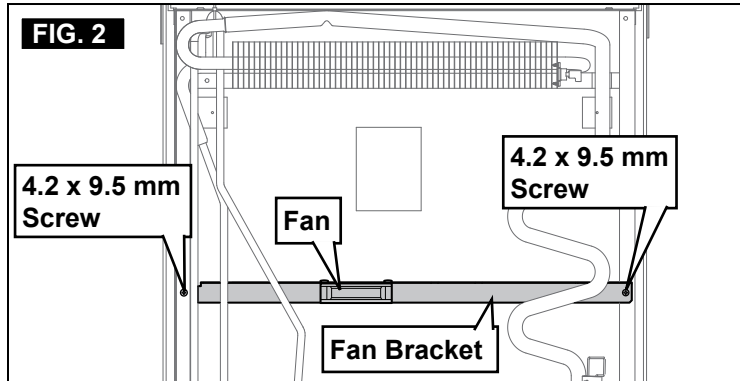

2. Mount the fan bracket with fan to the back of the refrigerator using the 4.2 x 9.5 mm screws.

B. Mounting The Thermal Switch

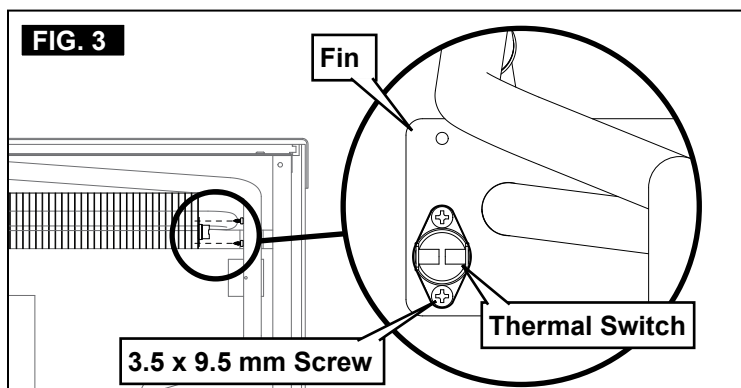

- Mount the thermal switch to the fin using the 3.5 x 9.5 mm screws.

C. Connecting The Wire Assembly

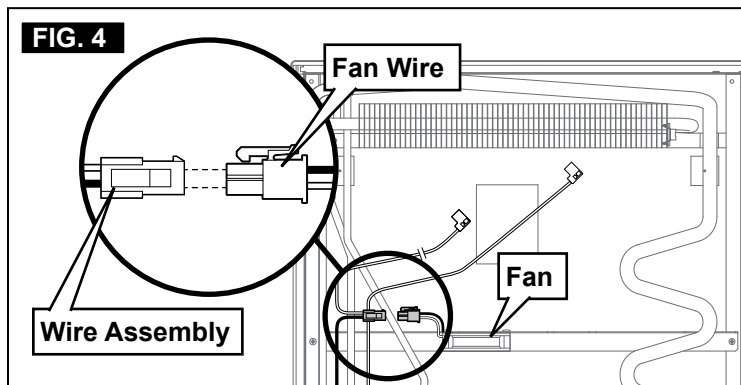

1. Connect the wire assembly to the fan wire.

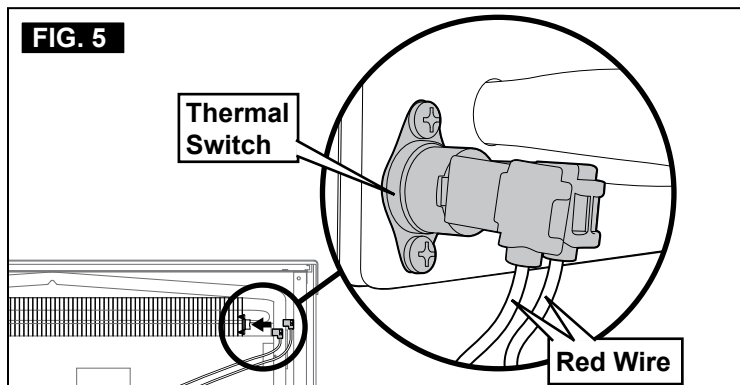

2. Connect the red wire from the wire assembly and the red fused wire assembly to the thermal switch.

INSTALLATION

D. Connecting The Fan Wires

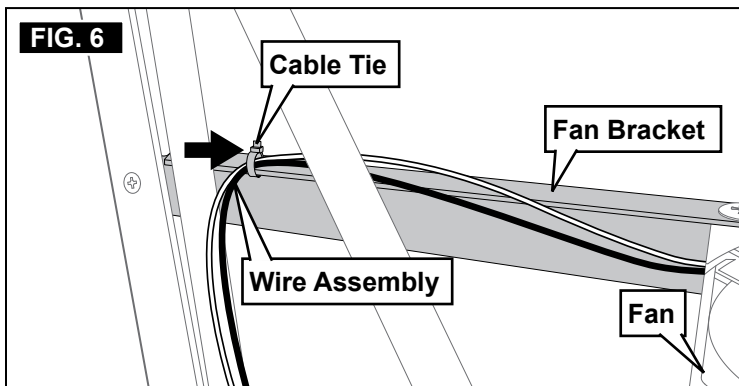

1. Secure the fan wires to the fan bracket with a cable tie.

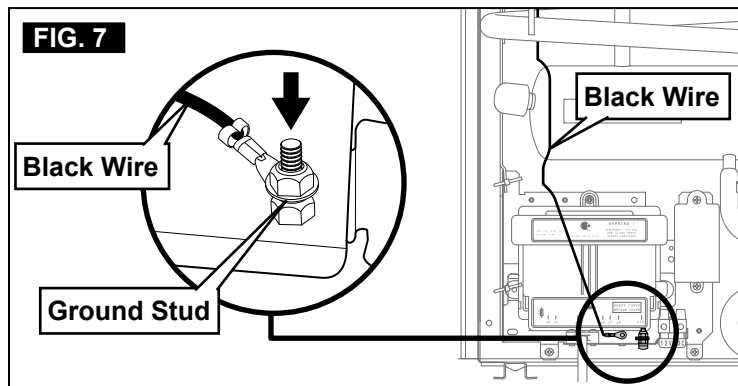

2. Connect the black wire to the ground stud.

E. Applying The Wiring Decal

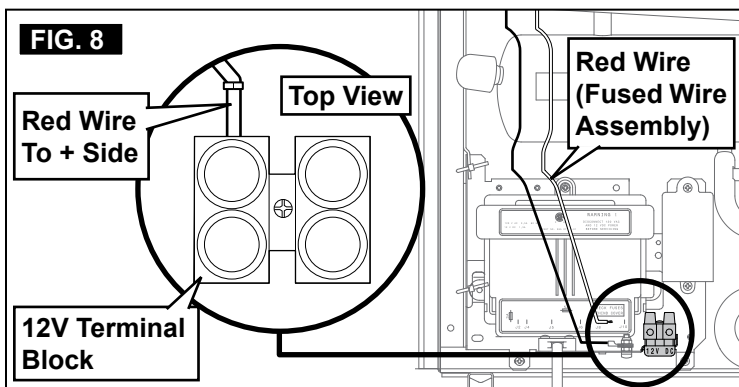

3. Connect the red fused wire assembly to the 12V terminal block.

4. Secure all wires as necessary.

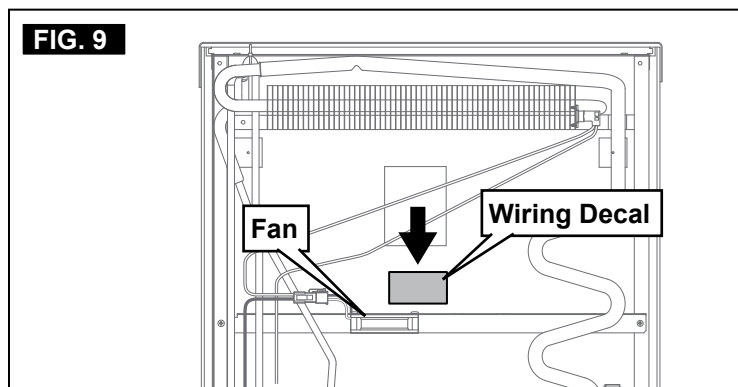

1. Place the wiring decal on the back of the refrigerator near the fan location.

Step 5

Reinstall refrigerator using industry standards and perform drop pressure test on propane gas system.

WARRANTY REIMBURSEMENT

Submit a claim on Key Express using **Flat Rate Code # 7135042K** with **Service Advisory # 19-350** noted in the customer complaint section. The amount of time authorized for installation is **2.0 hours** per vehicle.

Please call Keystone RV Customer Service at **(855) 382-4100** if you have any questions.