

PREVOST

Instruction Sheet

IS-19909A

BOSCH TO DELCO REMY ALTERNATOR INSTALLATION, X3-45 From E-5459 up to H-6179 (Can)/ H-7416 (US)





Revision A General revision. Kit 0610091 changed. Added missing Loctite requirement.
2019-04-05

MATERIAL



Order Main Kit **IS19909**, which contains

Part No.	Description	Qty
0610086	Alternator Mechanical Kit, Right	1
0610091	Adaptation Kit, Right, X3-45	1
IS-19909	Instruction Sheet	1
FI-19909	Feuille d'instructions	1

0610086 Alternator Mechanical Kit, Right

Part No.	Description		Qty
560720	Alternator Remy 55SI 24V-250A Pad Mount		1
069892	Pulley 8PK, 83 DOB		1
069894	Bracket, Alternator Remy		1
506065	Belt Poly V 8PK1435 EPDM QT+Aramide		2
5001308	SCREW CAP HEXF N500 M10-1.5X40 G10.9		4
5002091	SCREW CAP HEXF N500 M10-1.5X120 G10.9		4
5001137	WASHER FL SS .203X.438X.06 (M5,#10)		2
5001180	NUT HEX NYRT SS 10-24		2
500411	WASHER FL SS .260X.697X.05 (M6,1/4)		1
5001341	WASHER FL SS 8.4X17X1.6 (M8,5/16)		1
500685	NUT HEX NYRT 5/16-18 SS		1

0610091 Adaptation Kit, Right, X345

Part No.	Description		Qty
450580	BRACE, AC COMPRESSOR		1
5000360	STUD, M10-1.5X52 N500		1
5001834	WASHER BEL SPR 10.5X23X2.5 N500		1
5001930	NUT HEXF NYRT M10-1.5 N500 G10.9		1
N55439-02	RING TERMINAL 5MM / 16-14 / INSULATED		2
N33509-06	Shrink tubing		12"
0610030	Power cable RH alternator X345		1
0610034	Ground cable RH alternator		1

TOOLS

<p>15/16" THIN WALL CROWFOOT ADAPTER.</p> 	<p>680888 CLUTCH EXTRACTOR</p> 	<p>METRIC OPEN END WRENCH SET</p> 
<p>RATCHET, SOCKET, HEX BIT SET – METRIC</p> 	<p>LAPTOP W/ RS232 SERIAL ADAPTER & 066009 CABLE¹</p> 	<p>TORQUE WRENCH</p> 
<p>SOFT FACED HAMMER</p> 	<p>1 5/8 OPEN END WRENCH</p> 	<p>BELT TENSION GAUGE</p> 
<p>1/2 SQUARE DRIVE BREAKER BAR</p> 	<p>VOLTMETER / MULTIMETER</p> 	<p>CUTTING PLIERS</p> 

¹ VPG software or a MUX update package may be required on some vehicles. Contact your PrevoSt customer service manager for details.

PROCEDURE



DANGER

Park vehicle safely, apply parking brake, stop engine. Prior to working on the vehicle, set the ignition switch to the OFF position and trip the main circuit breakers equipped with a trip button. On Commuter type vehicles, set the battery master switch (master cut-out) to the OFF position. Apply vehicle lockout procedures according to local policies.

Table of contents

OVERVIEW	4
ELECTRICAL SCHEMATICS	5
BOSCH ALTERNATORS REMOVAL, RIGHT HAND SIDE	6
RIGHT HAND ALTERNATOR INSTALLATION	11
RIGHT HAND ALTERNATOR INSTALLATION (CONTINUED)	13
RIGHT HAND ALTERNATOR CONNECTIONS	16
ALTMGM PARAMETER CHANGE	19
FUNCTIONAL TESTING	19
APPENDIX A – LTD WIRE GUIDELINES	21
LABOR REFERENCE TABLE.....	23

OVERVIEW

For vehicles with PRIME battery management, a parameter value must be changed in the vehicle's multiplex system. This requires a laptop with the proper serial cable and software. See TOOLS.

Make an appointment with your nearest Prevest service center. *If you choose to perform the procedure yourself, contact your Prevest customer support manager before starting.*

The procedure involves removing the existing Bosch alternators, their corresponding brackets and harnesses and replacing them with a Delco Remy 55SI alternator.

The alternators require new brackets and harnesses.

First time users should read the procedure before starting work on a vehicle. Best viewed in color.

ELECTRICAL SCHEMATICS

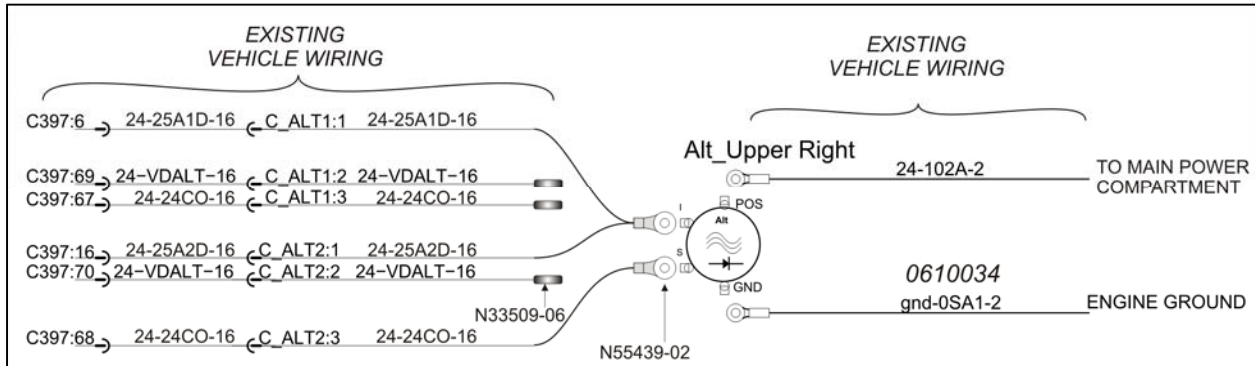

FIGURE 1: ALTERNATOR CONNECTIONS W/ HARNESS NUMBERS

BOSCH ALTERNATORS REMOVAL, RIGHT HAND SIDE

1. Loosen bolt **A** on A/C belt tensioner.
2. Unscrew **B**.
3. Remove the mechanical tensioner assembly.
4. Remove the A/C compressor drive belts (2 side-by-side belts).

Note: Keep hardware for reuse in next steps

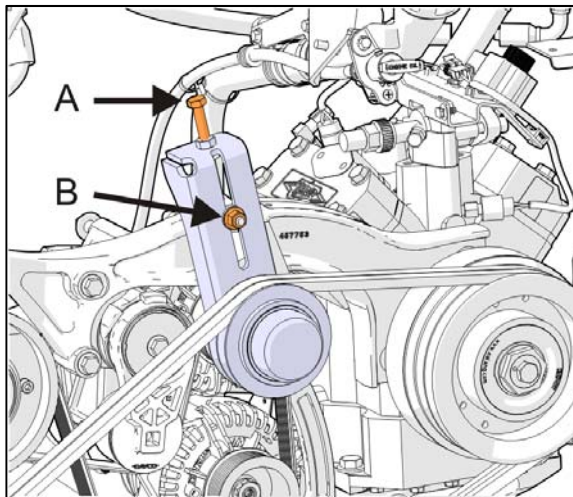

FIGURE 2

450580 BRACE PRE-ASSEMBLY

5. Install stud 5000360 with Red Loctite 271 on new modified compressor brace 450580.
6. Install it so it exceeds by 25mm. Place 5001834 Belleville washer and hand thread 5001930 flange nut.

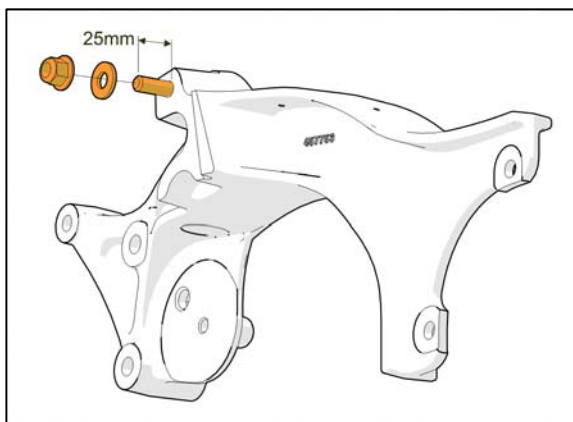

FIGURE 3

7. Remove the LANG electromagnetic clutch assembly.

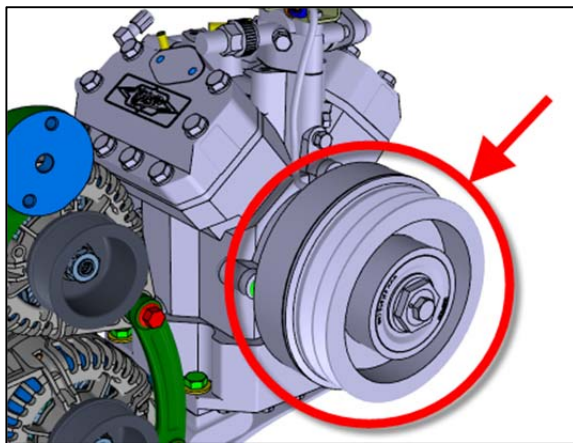
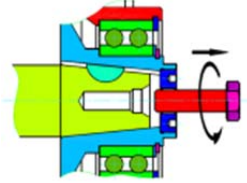

FIGURE 4

8. Hold the rotor with the 1 5/8 wrench. Loosen and remove the M12 rotor mounting screw.



REMOVING THE M12 SCREW

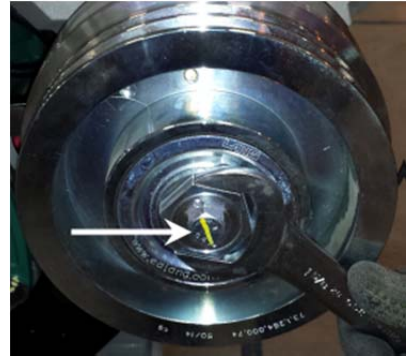
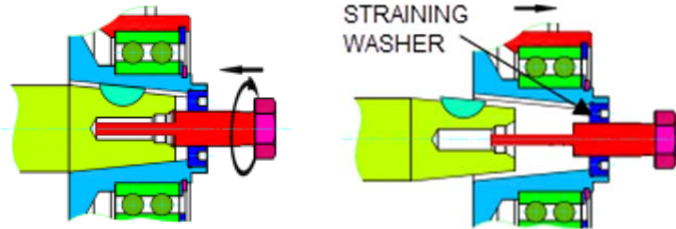

FIGURE 5

For the next step, use rotor extractor tool #680888.

9. Screw the extractor tool into the straining washer only until the rotor pops off the tapered shaft. Then work the rotor off the shaft by hand with help from soft faced mallet as needed.



PULL OFF THE ROTOR WITH TOOL #680888 (shown)

TAKE OFF THE ROTOR
FIGURE 6

10. Loosen the fastening screws (4x) of the coil and pull the coil off the retainer.

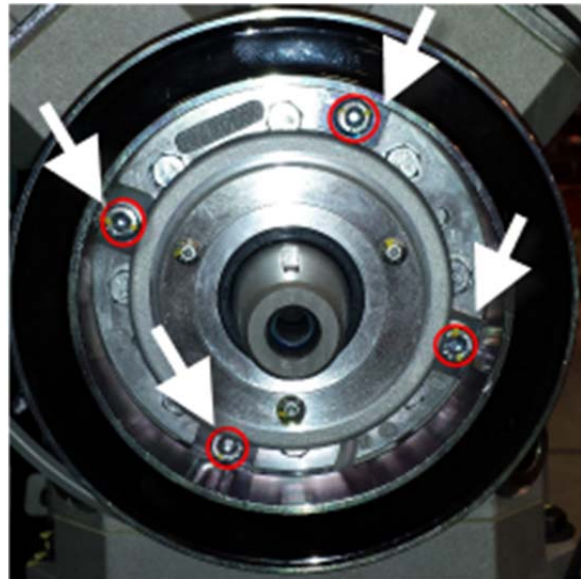

FIGURE 7

11. Remove the support bracket mounting bolts on the engine. *Keep for reuse.*
12. Remove the belt tensioner bolt. Reserve for re-use.
13. Remove and discard the alternator drive belt.

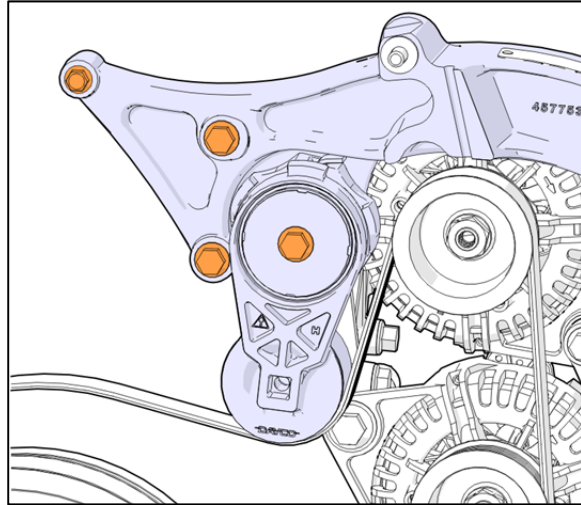

FIGURE 8

14. Unscrew and remove two socket cap screws.
15. Discard the reinforcement bracket.
16. Keep hardware for re-use.

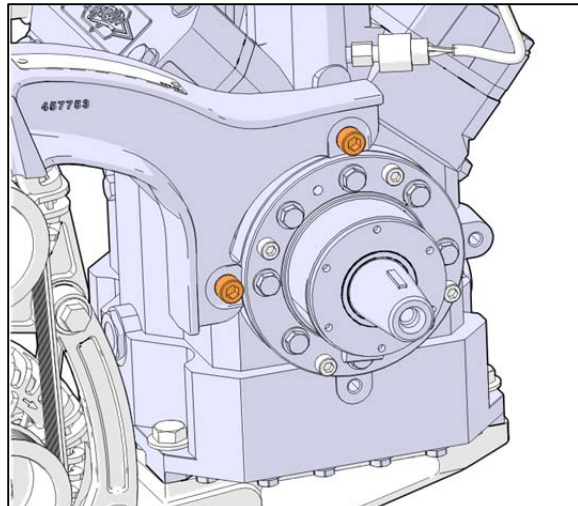

FIGURE 9

17. Remove compressor mounting bolts and reserve. Move compressor slightly aside to provide additional working space.

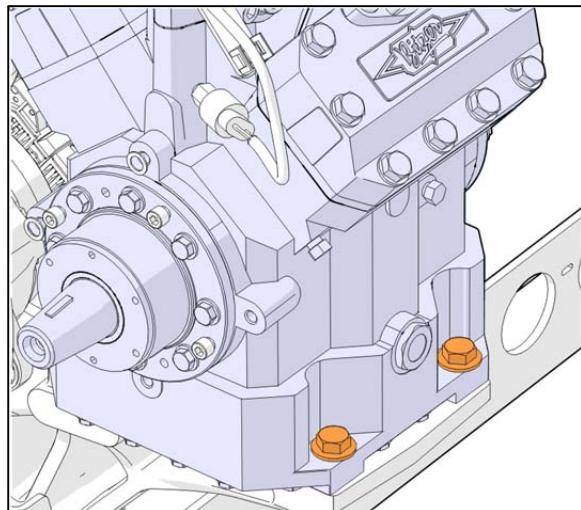

FIGURE 10

 **WARNING**

The alternator is connected to the batteries through master relay R1. If the ignition switch is in the OFF position and the battery master switch (master cut-out) is set to the OFF position, there should not be electrical power to the alternator terminals. However, a faulty master relay R1 could eventually leave the battery power circuit closed, thus electrical power would be present at the alternator terminals.

Using a multimeter, probe the alternator **B1+** terminal and the ground terminal. Make sure that the voltage reading is 0 volt before disconnecting the alternator cables.

18. Disconnect the *Power, Jumper, Control Harness* and *Ground cables* from the alternators.

Discard ground cable.

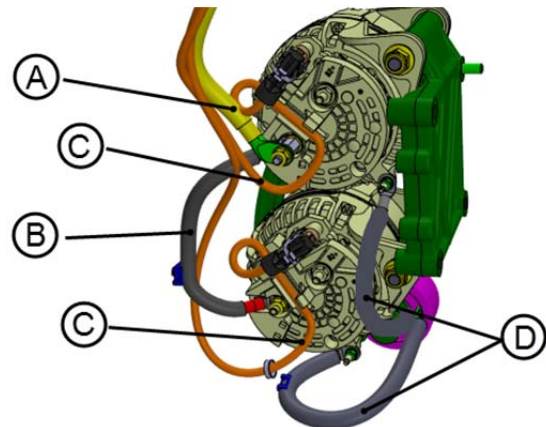

FIGURE 11

- A: (+) POWER CABLE
- B: (+) JUMPER CABLE
- C: CONTROL HARNESS
- D: GROUND CABLE

19. Remove the existing alternators. To do so, unscrew the four (4) mounting bolts identified on the figure. Discard bolts and alternators.

20. Also remove the idler at the bottom. Discard idler and hardware.

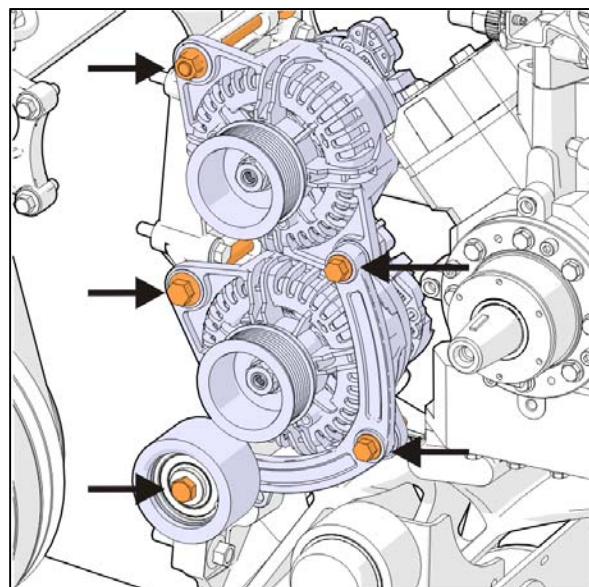

FIGURE 12

21. Remove the alternator support bolted on the engine. Discard support and bolts.

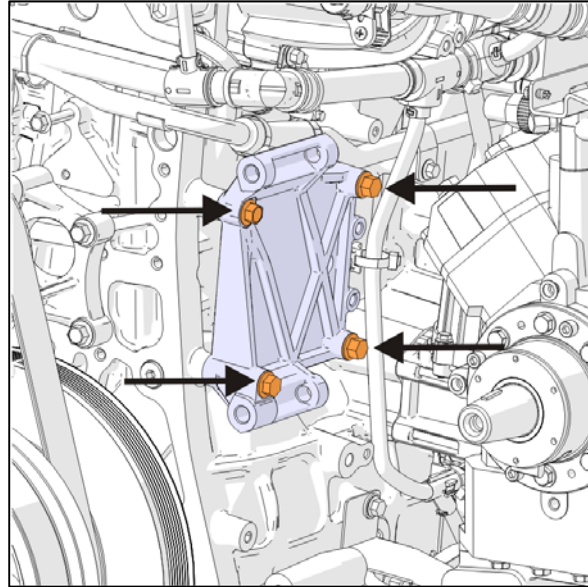

FIGURE 13

RIGHT HAND ALTERNATOR INSTALLATION

22. Installing the alternator pulley.

Place 560720 alternator flat on a bench with the shaft horizontal.

Required tools:

- 15/16" crowfoot adapter
- 8mm hex bit

Clean shaft and pulley with brake cleaner.

Slide pulley 069892 on shaft by hand.

Hand thread nut on shaft until snug.

Using 15/16" adapter and 8mm hex bit to block shaft rotation, tighten to **70-80 lb-ft.**

Apply torque seal

Never use power tools to install pulley and nut.

Note: Do not apply any pressure to end of the shaft. Internal damage may occur if the shaft is pushed back and turned.

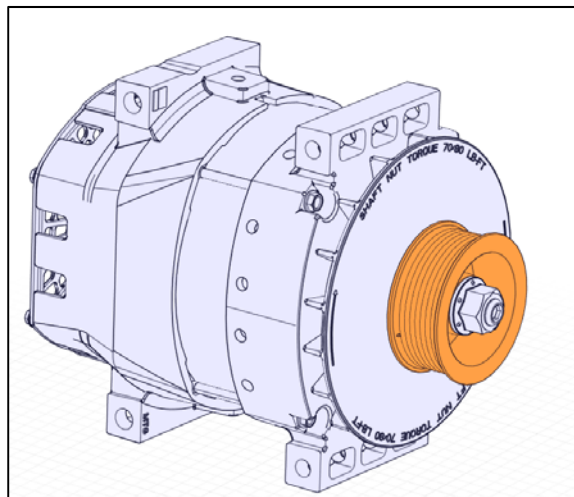

FIGURE 14

23. Install bracket 069894 on engine with four (4) 5001308 M10x40 bolts.

Apply blue Loctite 243

Tighten to **35 lb-ft.**

Apply torque seal.

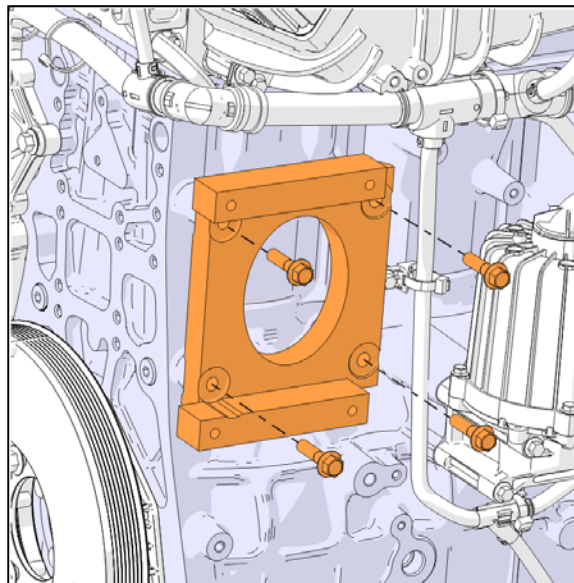

FIGURE 15

24. Install alternator on engine with four (4)
5002091 M10x120 bolts.

Apply blue Loctite 680038

Tighten to **48 lb-ft**

Apply torque seal.

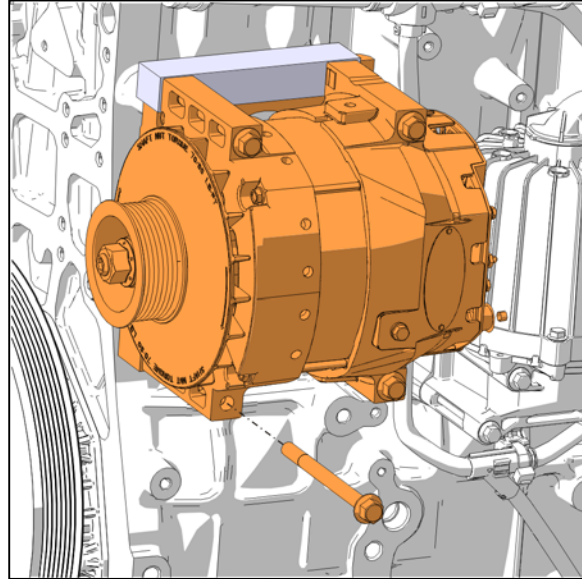

FIGURE 16

RIGHT HAND ALTERNATOR INSTALLATION (continued)

25. Re-install compressor mounting bolts by hand. *Do not tighten yet.*

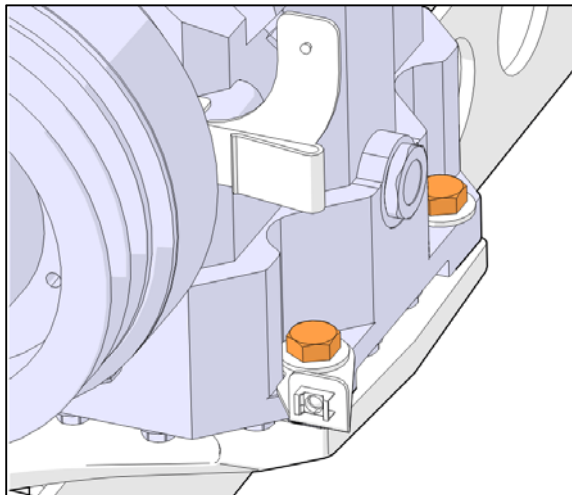

FIGURE 17

26. Install *new* compressor brace support 450580.

Install reserved hardware by hand. Then tighten.

Tighten **C** to **43 lb-ft**

Tighten **D** to **22 lb-ft**

Tighten **E** to **40 lb-ft** (use blue Loctite 243)

Tighten compressor mounting bolts to **82 lb-ft**

Apply torque seal.

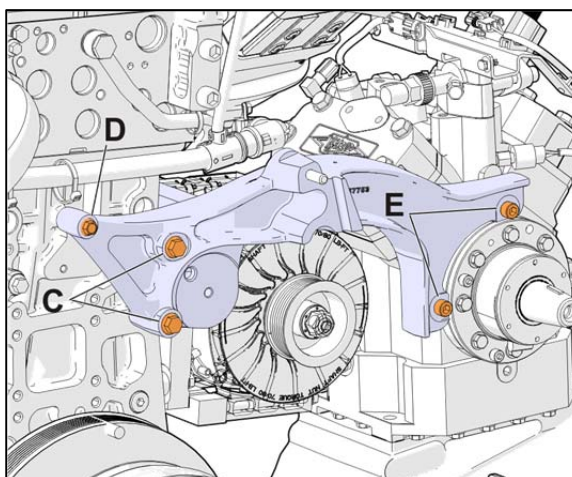

FIGURE 18

27. Install the alternator belt tensioner with hardware **E** reserved earlier.

Tighten to **48 lb-ft.** (use blue Loctite 243)

Apply torque seal

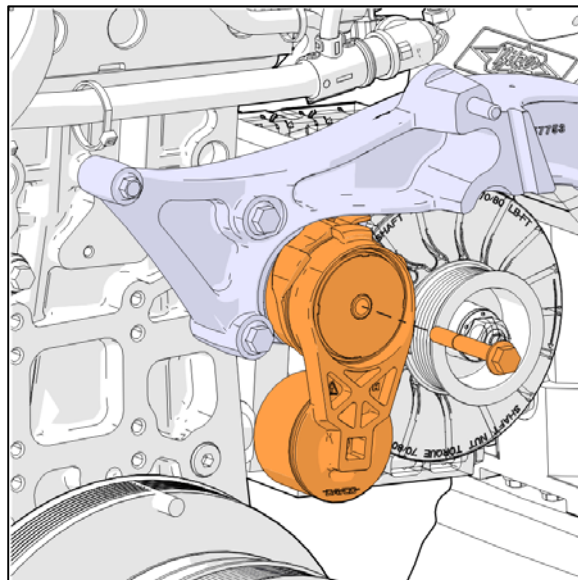

FIGURE 19

28. Install alternator belt 506065. To do so, rotate the automatic belt tensioner using a ½ square drive breaker bar.

Keep the spare 506065 belt in the vehicle.

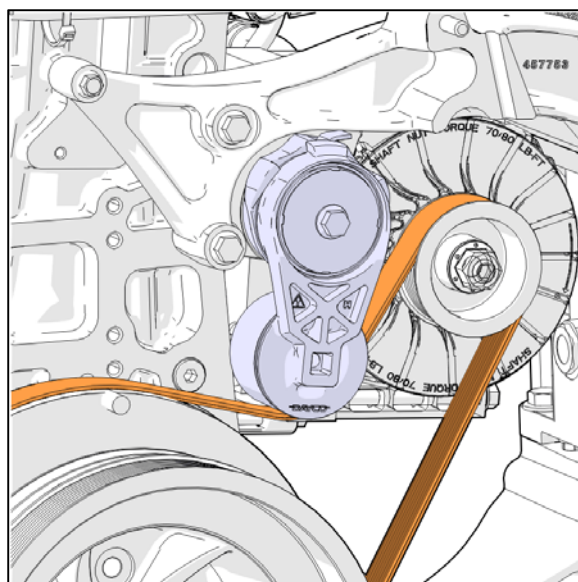

FIGURE 20

29. Install A/C clutch coil.

Use blue Loctite 243

Tighten to **22lb-ft**

Apply torque seal

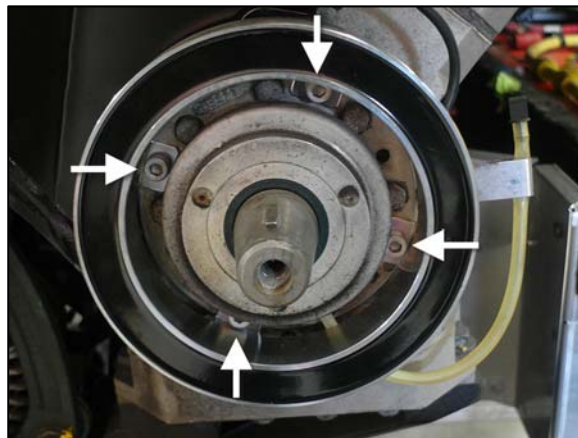

FIGURE 21

30. Mount the rotor on the shaft end.

The flange and the shaft end of the compressor must be free from dirt.

Apply high temperature approved assembly grease on the shaft end for easy dismounting of the clutch. Lang recommends the use of Molykote G-rapid-plus or Molykote P 40.

31. Carefully mount the rotor on the shaft end by hand.

Never use a hammer for pressing the rotor on.

Align the key on the compressor shaft with the keyway on the pulley bore. To avoid damaging the bore of the rotor, feel the engagement of the key in the keyway and slip the rotor on the shaft end of the compressor till reaching the stop.

The Woodruff key on the shaft end and the groove in the location hole of the rotor must be flush.



FIGURE 22

32. Fasten the rotor to the shaft end using the M12 screw and by holding-up with a wrench on the rotor.
33. Turn rotor by hand and pay attention to the free run and the generation of noises. In case of grinding or similar noises, dismount the clutch and check installation.

Use blue loctite 243 on threads

Tighten to **60lb-ft**

Apply torque seal

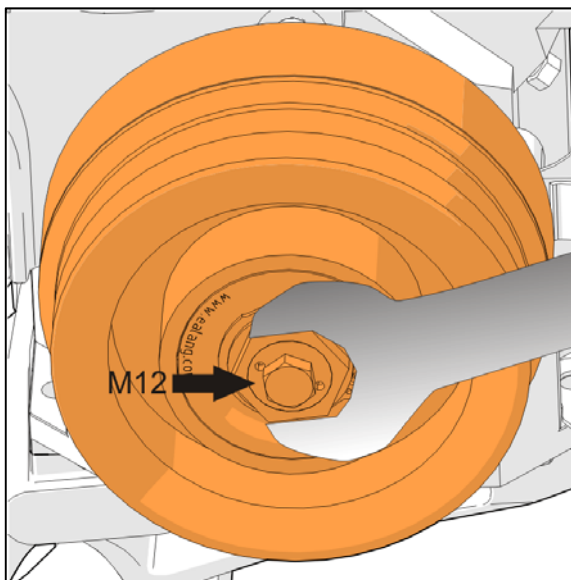

FIGURE 23

34. Re-install A/C belt tensioner and belt.

A belt strand tension gauge is needed. Belt tension should be within the following range:

- 90-100 lbs new belts (mean of 2 belt values)
- 75-85 lbs used belts (mean of 2 belt values)

35. Apply blue Loctite 243 on **B** threads and then hand-tighten **B**. Adjust belt tension using bolt **A**. Use the jam nut at the base of bolt **A** to keep proper tension adjustment.

Note: Once thread locker is applied, do not wait too long before applying final torque.

When proper tension is achieved, tighten **B** to **43 lbf-ft.** (58 N-m).

Apply torque seal

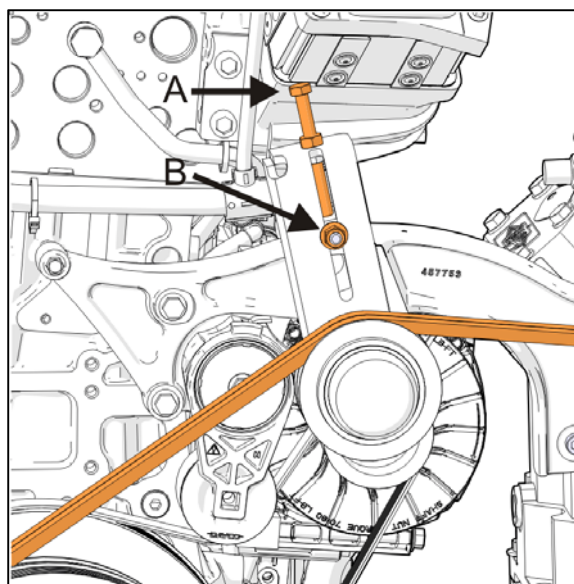

FIGURE 24

RIGHT HAND ALTERNATOR CONNECTIONS

36. Open the Bosch alternator connectors by rotating the metal lock and prying open the plastic cap.

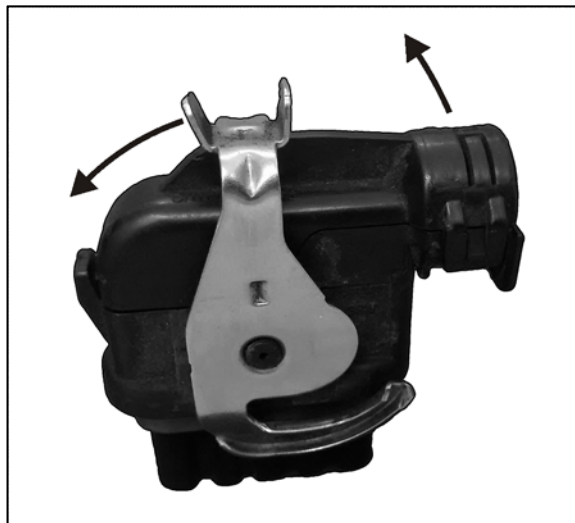

FIGURE 25

37. On the *upper* alternator connector, cut the white wire at position **2**. Crimp ring terminal N55439-02. Seal connection by melting shrink Tag and identify "25A1".
38. Cut the other two red wires at positions **3** and **4**. Seal with N55439-01 shrink tube.
39. On the *lower* alternator connector, cut the white wire at position **2**. Crimp ring terminal N55439-02. Seal connection by melting shrink Tag and identify "25A2".
40. Cut red wire at position **3**. Crimp ring terminal N55439-02. Seal connection by melting shrink Tag and identify "24ALT".
41. Cut and seal the wire at position **4** with N55439-01 shrink tube.

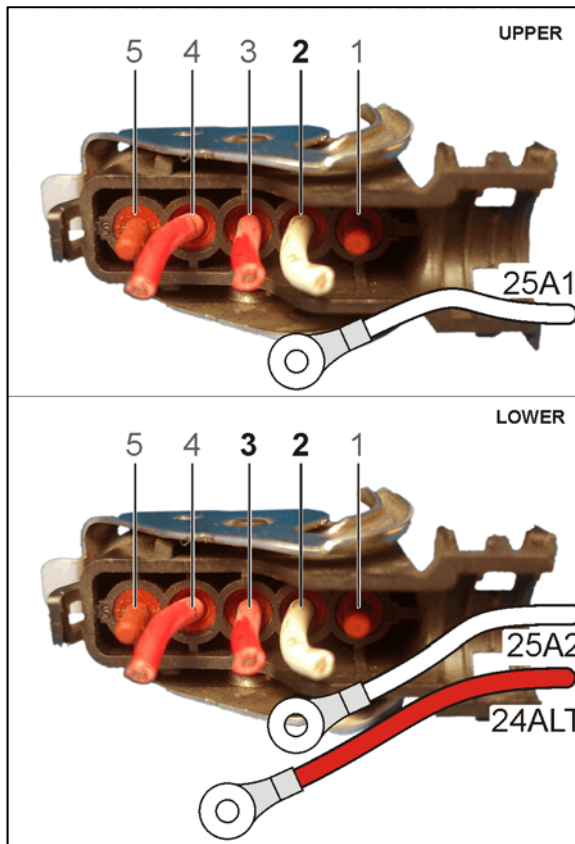

FIGURE 26

42. Connect ring terminals 25A1 and 25A2 (on Indicator, "I"; 24Alt on Sense, "S").

Use 5001180 10-24 Nylon lock nut and 5001137 washer.

43. Tighten to the following torque values:

Sense: **25-45 lb-in (3.0 5.0 N-m)**

Indicator: **25-45 lb-in (3.0 5.0 N-m)**

Note: After completing tests, Apply color guard 684013 on all connections.

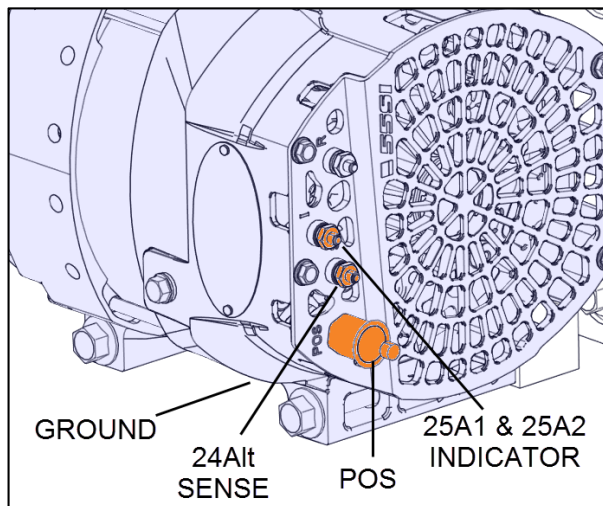

FIGURE 27

44. Install ground cable 0610034 on alternator.

Add 500411 SS Washer.

Tighten to **50-60 lb-in (5.6-6.8 N-m)**

45. Install existing power cable on alternator.

See **NOTE** below

Use 500685 Nylon lock nut and 5001341 SS Washer.

Tighten to **80-125 lb-in (9.0-14.0 N-m)**

46. Connect ground cable to the engine.

Tighten to **240 lb-in.**

Note: After completing tests, Apply color guard 684013 on all connections.

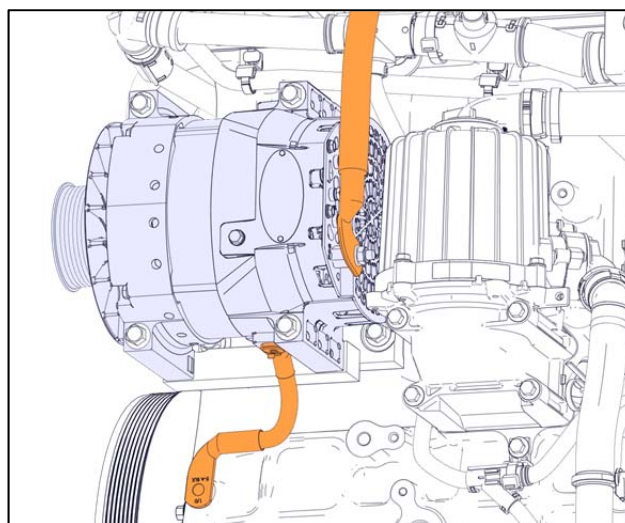

FIGURE 28

NOTE on positive stud :

Early versions of the alternator have a shorter positive stud.

Nut 500685 does not thread fully on the shorter stud to allow the locking nylon lock to grip on the threads.

In this situation, use the *nut and lock washer* provided with the alternator.

Tighten to: **80-125 lb-in (9.0-14.0 N-m)**.

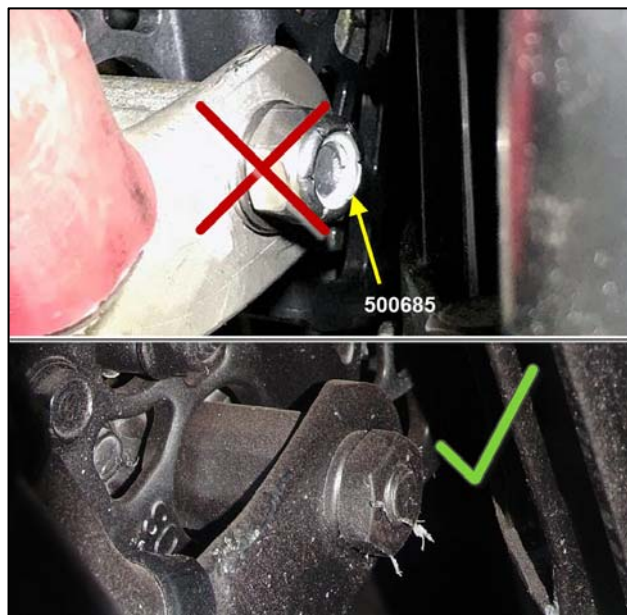

FIGURE 29: HARDWARE TO USE WITH EARLY VERSIONS

- 47. Secure control harness and power cable together with double loop cable ties as shown in images below.
- 48. If the red LTD wire was disturbed by dismantling of the Bosh wiring, secure it using the recommendations outlined in Appendix A “LTD wire guidelines”.

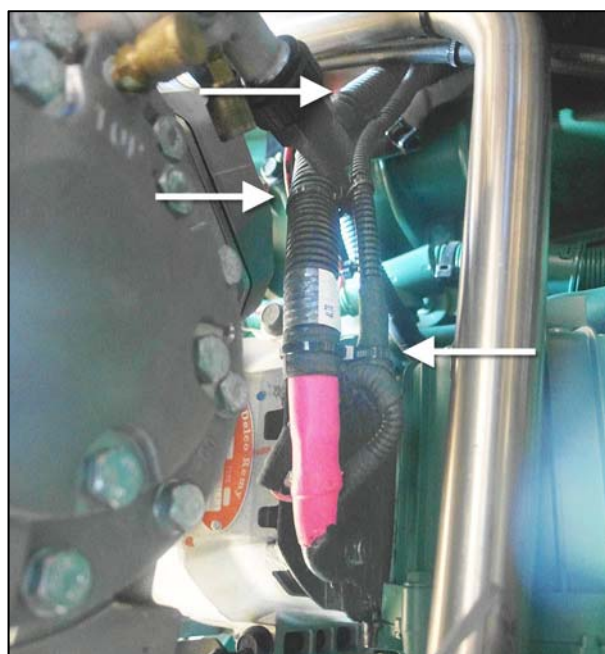

FIGURE 30

ALTMGM PARAMETER CHANGE

Contact your Prevest Customer support manager if you require assistance for this step.

Multiplex parameter ALTMGM value must be *No*.

FUNCTIONAL TESTING

49. Reset main circuit breakers if applicable. Set the battery master switch (master cut-out) to the ON position and start the engine. Make sure that the charging system is working normally.

On the instruments cluster, the alternator telltale  illuminates if the alternators are not charging.

APPENDIX A – LTD WIRE GUIDELINES

IMPORTANT: If the LTD wire is disturbed; the following guidelines must be followed to secure it properly.

NOTE

Always use double loop cable ties to secure LTD. LTD must be tied alone, with no other cables in the loop.

NOT ALLOWED

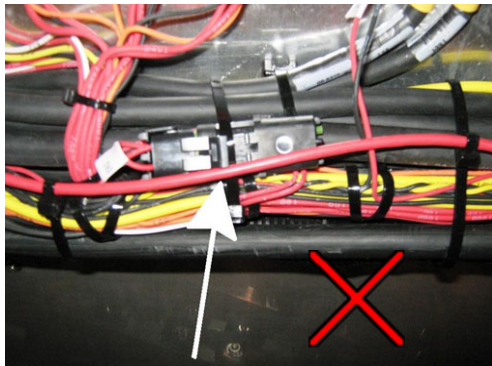

Possible contact or rubbing against screws, edges, etc.

CORRECT

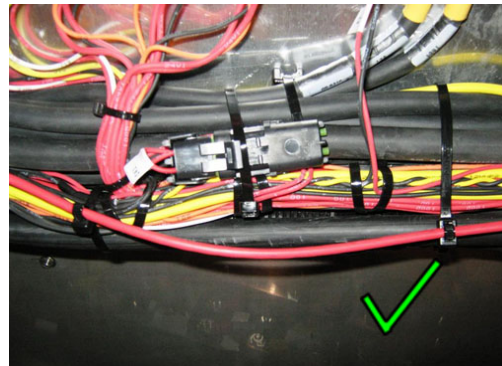

LTD must be routed clear of screws, sharp edges, etc.

NOT ALLOWED

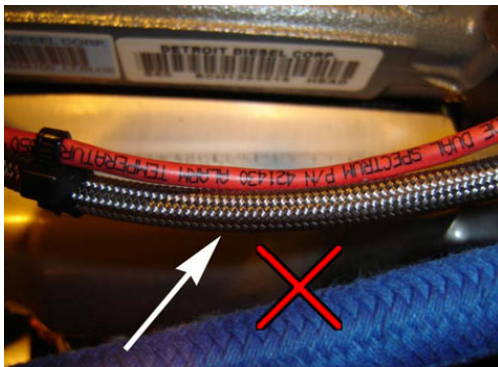

Rubbing or possible rubbing against abrasive surfaces

CORRECT

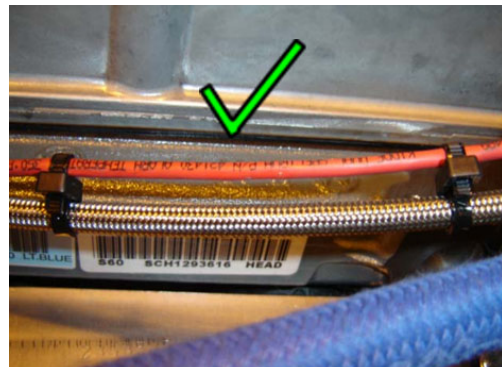

LTD must be secured with double loop cable ties. Distance between cable ties must not exceed 4 inches (100mm) max

NOT ALLOWED

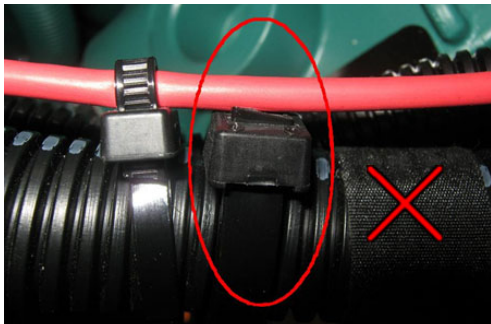

LTD touching cut cable tie

NOT ALLOWED



LTD extending slantingly from the cable tie

NOT ALLOWED



Cable tie tighten in excess on the LTD. Tighten cable tie on LTD by hand only. Tighten just enough to prevent LTD from slipping from one side to the other inside the cable tie loop

CORRECT

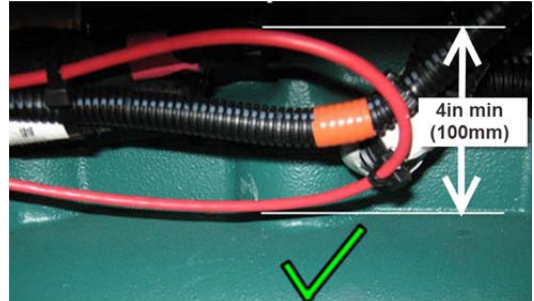

LTD is not a flexible harness. Avoid tight bends and kinks which could short circuit the LTD. Loops must have a minimum radii of 4 inches (100 mm)

CORRECT

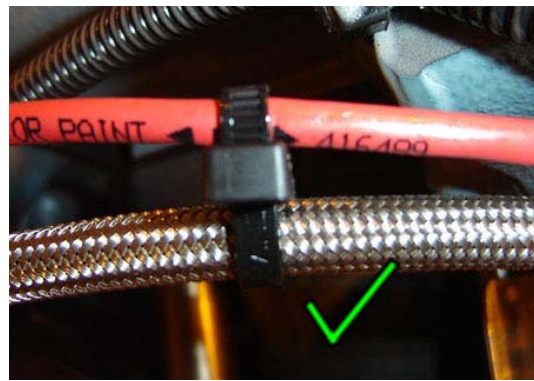

Proper tightening of the cable tie on the LTD

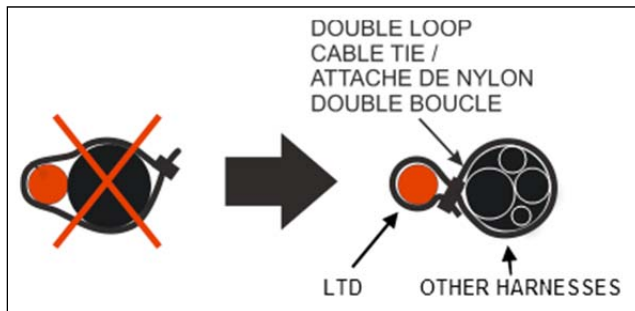

LABOR REFERENCE TABLE

Table for reference only.

Actual times will vary depending on vehicle condition.

	<i>Operation</i>	<i>Approximate labor (hours)</i>
Step 1	BOSCH ALTERNATORS REMOVAL, RIGHT HAND SIDE	1h
Step 2	INSTALLING THE RIGHT HAND ALTERNATOR. (includes wiring)	2h
Step 3	FUNCTIONAL TESTING	0.5h
	Total	3.5 hours

PARTS / WASTE DISPOSAL

Discard waste according to applicable environmental regulations (Municipal/State[Prov.]/ Federal)