

# Service Alert

Mazda North American Operations  
Irvine, CA 92618-2922



<b>Subject:</b>  2019 MAZDA3 SERVICE CAUTIONS FOR NEW AND REVISED FEATURES	<b>Service Alert No.:</b> SA-010/19
	<b>Last Issued:</b> 04/11/2019

## BULLETIN NOTES

This Service Alert supersedes the previously issued Service Alert(s) listed below: The changes are noted in Red.

Previous Service Alert(s):	Date(s) Issued:
SA-010/19	03/29/2019, 03/21/2019, 03/15/19,03/08/19, 03/06/19, 03/05/19, 02/25/19

## APPLICABLE MODEL(S)/VINS

2019 Mazda3

## DESCRIPTION

The new 2019 Mazda3 has new and revised features that are different from previous models, and may be difficult to understand. This Service Alert provides valuable information to support potential dealer and customer concerns.

**CONSUMER NOTICE:** The information and instructions in this bulletin are intended for use by skilled technicians. Mazda technicians utilize the proper tools/equipment and take training to correctly and safely maintain Mazda vehicles. These instructions should not be performed by "do-it-yourselfers." Customers should not assume this bulletin applies to their vehicle or that their vehicle will develop the described concern. To determine if the information applies, customers should contact their nearest authorized Mazda dealership. Mazda North American Operations reserves the right to alter the specifications and contents of this bulletin without obligation or advance notice. All rights reserved. No part of this bulletin may be reproduced in any form or by any means, electronic or mechanical---including photocopying and recording and the use of any kind of information storage and retrieval system ---without permission in writing.

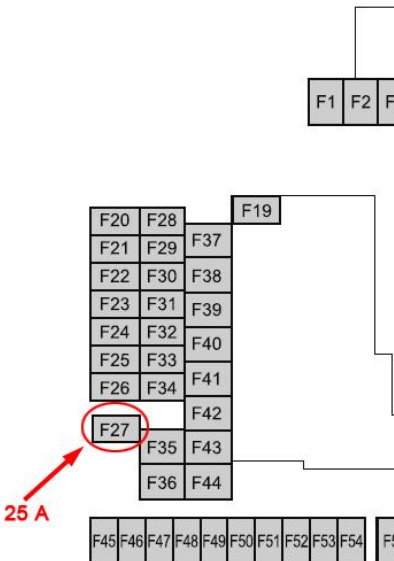
Item	Service Information
<p>Fuse to be Installed at PDI</p> <ol style="list-style-type: none"> <li>1. There is only one fuse removed at the factory that should be installed at PDI. It is fuse F27 (25A). The fuse is stored in the lid of the fuse box with the spare fuses.</li> <li>2. The current PDI form is wrong. It states there are two (2) fuses removed (F46 and F50) that should be installed. The form is being updated with this change.</li> </ol>	<p><b>Fuse Block (Engine Compartment)</b></p>  <p>The diagram shows a fuse block layout with fuses labeled F1 through F54. Fuses F1, F2, and F3 are in a top row. Fuses F19, F20, F28, F21, F29, F37, F22, F30, F38, F23, F31, F39, F24, F32, F40, F25, F33, F41, F26, F34, F42, F27, F35, F43, F36, F44 are in a larger central grid. Fuses F45, F46, F47, F48, F49, F50, F51, F52, F53, F54 are in a bottom row. Fuse F27 is circled in red, and a red arrow points to it with the label '25 A'.</p>
<p>Front Wiper Service Caution</p> <ol style="list-style-type: none"> <li>1. Wiper arm park position is located under the hood.</li> <li>2. When servicing front wipers, front wiper service mode is required or damage to wiper arms may occur (see Service Information).</li> <li>3. If wiper arms are replaced, M-MDS is needed for wiper arm adjustment (see Service Information)</li> <li>4. DO NOT use wiper arms as markers when in dealer inventory.</li> </ol>	<p>See Owner's Manual -&gt; Maintenance and Care &gt; Replacing Windshield Wiper Blades</p> <p>MGSS: WINDSHIELD WIPER ARM AND BLADE ADJUSTMENT</p>

**CONSUMER NOTICE:** The information and instructions in this bulletin are intended for use by skilled technicians. Mazda technicians utilize the proper tools/equipment and take training to correctly and safely maintain Mazda vehicles. These instructions should not be performed by "do-it-yourselfers." Customers should not assume this bulletin applies to their vehicle or that their vehicle will develop the described concern. To determine if the information applies, customers should contact their nearest authorized Mazda dealership. Mazda North American Operations reserves the right to alter the specifications and contents of this bulletin without obligation or advance notice. All rights reserved. No part of this bulletin may be reproduced in any form or by any means, electronic or mechanical---including photocopying and recording and the use of any kind of information storage and retrieval system ---without permission in writing.

i-ACTIVSENSE Switch (New)



<p>When i-ACTIVSENSE is in normal operating status, the instrument cluster i-ACTIVSENSE indicator is green.</p>	<p>Activated Status: Green</p>
<p>When i-ACTIVSENSE has an environmental fault, such as a dirty windshield or driving into the sun, the instrument cluster i-ACTIVSENSE indicator is white.</p>	<p>Stand-by Status: White</p>
<p>When i-ACTIVSENSE has a fault that needs diagnosis by a dealership, the instrument cluster i-</p>	<p>Warning Status: Amber</p>

See Owner's Manual ->  
When Driving -> i-ACTIVSENSE ->  
i-ACTIVSENSE

**CONSUMER NOTICE:** The information and instructions in this bulletin are intended for use by skilled technicians. Mazda technicians utilize the proper tools/equipment and take training to correctly and safely maintain Mazda vehicles. These instructions should not be performed by "do-it-yourselfers." Customers should not assume this bulletin applies to their vehicle or that their vehicle will develop the described concern. To determine if the information applies, customers should contact their nearest authorized Mazda dealership. Mazda North American Operations reserves the right to alter the specifications and contents of this bulletin without obligation or advance notice. All rights reserved. No part of this bulletin may be reproduced in any form or by any means, electronic or mechanical---including photocopying and recording and the use of any kind of information storage and retrieval system ---without permission in writing.

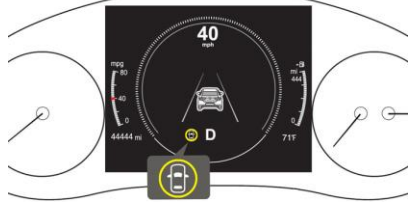
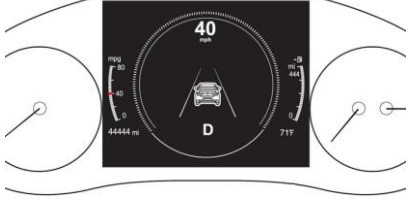
<p>ACTIVSENSE indicator is amber.</p>		
<p>When the i- ACTIVSENSE switch is pressed <i>and released immediately</i>, the following systems are canceled.</p> <ol style="list-style-type: none"> <li>1. Lane Departure Warning System (LDWS)</li> <li>2. Blind Spot Monitoring (BSM)</li> <li>3. Distance Speed Alert (DSA)</li> <li>4. Rear Cross Traffic Alert (RCTA)</li> <li>5. Lane-keep Assist System (LAS)</li> </ol> <p>To turn the system back to "Activated Status" , press the i- ACTIVSENSE switch once.</p>	<p style="text-align: center;"><b>Partially Cancelled Status: INDICATOR IS TURNED OFF</b></p> 	

**CONSUMER NOTICE:** The information and instructions in this bulletin are intended for use by skilled technicians. Mazda technicians utilize the proper tools/equipment and take training to correctly and safely maintain Mazda vehicles. These instructions should not be performed by "do-it-yourselfers." Customers should not assume this bulletin applies to their vehicle or that their vehicle will develop the described concern. To determine if the information applies, customers should contact their nearest authorized Mazda dealership. Mazda North American Operations reserves the right to alter the specifications and contents of this bulletin without obligation or advance notice. All rights reserved. No part of this bulletin may be reproduced in any form or by any means, electronic or mechanical---including photocopying and recording and the use of any kind of information storage and retrieval system ---without permission in writing.

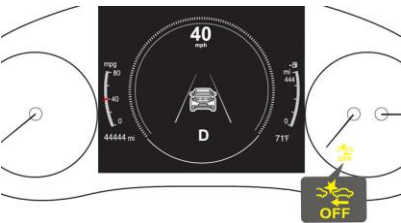
<p><b>NOTE: If MRCC is used, the system will also return to "Activated Status".</b></p>		
<p>When the i-ACTIVSENSE switch is pressed <i>and held</i>, all systems are canceled.</p> <ol style="list-style-type: none"> <li>1. Lane Departure Warning System (LDWS)</li> <li>2. Blind Spot Monitoring (BSM)</li> <li>3. Distance Speed Alert (DSA)</li> <li>4. Rear Cross Traffic Alert (RCTA)</li> <li>5. Lane-keep Assist System (LAS)</li> <li>6. Smart Brake Support (SBS)</li> <li>7. Smart Brake Support [Rear] (SBS-R)</li> </ol>	<p style="text-align: center;">Fully Cancelled Status:  <b><i>I-ACTIVSENSE INDICATOR IS OFF</i></b>  <b><i>SBS OFF WARNING LIGHT IS ON</i></b></p> 	

**CONSUMER NOTICE:** The information and instructions in this bulletin are intended for use by skilled technicians. Mazda technicians utilize the proper tools/equipment and take training to correctly and safely maintain Mazda vehicles. These instructions should not be performed by "do-it-yourselfers." Customers should not assume this bulletin applies to their vehicle or that their vehicle will develop the described concern. To determine if the information applies, customers should contact their nearest authorized Mazda dealership. Mazda North American Operations reserves the right to alter the specifications and contents of this bulletin without obligation or advance notice. All rights reserved. No part of this bulletin may be reproduced in any form or by any means, electronic or mechanical---including photocopying and recording and the use of any kind of information storage and retrieval system ---without permission in writing.

8. Smart Brake Support [Rear Crossing] (SBS RC)		

**CONSUMER NOTICE:** The information and instructions in this bulletin are intended for use by skilled technicians. Mazda technicians utilize the proper tools/equipment and take training to correctly and safely maintain Mazda vehicles. These instructions should not be performed by "do-it-yourselfers." Customers should not assume this bulletin applies to their vehicle or that their vehicle will develop the described concern. To determine if the information applies, customers should contact their nearest authorized Mazda dealership. Mazda North American Operations reserves the right to alter the specifications and contents of this bulletin without obligation or advance notice. All rights reserved. No part of this bulletin may be reproduced in any form or by any means, electronic or mechanical---including photocopying and recording and the use of any kind of information storage and retrieval system ---without permission in writing.

Traffic Sign Recognition (TSR) Inoperative  
 TSR is only available with a dealer installed in-vehicle navigation system accessory.

See Owner's Manual ->  
 When Driving -> i-ACTIVSENSE ->  
 i-ACTIVSENSE -> Traffic Sign  
 Recognition System (TSR)

MGSS: Traffic Sign Recognition  
 (TSR)

MAZDA CONNECT New Power Off Function



1. Audio Mute - Short press the volume knob (Press again to cancel)
2. Power Off - Press and hold the volume knob (Press and hold again to Power ON)

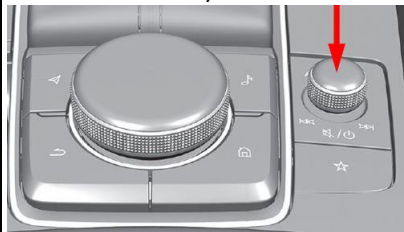

See Owner's Manual ->  
 Interior Features -> Mazda  
 Connect

MGSS: ENTERTAINMENT SYSTEM

In-vehicle Owner's Manual  
 installation

**CONSUMER NOTICE:** The information and instructions in this bulletin are intended for use by skilled technicians. Mazda technicians utilize the proper tools/equipment and take training to correctly and safely maintain Mazda vehicles. These instructions should not be performed by "do-it-yourselfers." Customers should not assume this bulletin applies to their vehicle or that their vehicle will develop the described concern. To determine if the information applies, customers should contact their nearest authorized Mazda dealership. Mazda North American Operations reserves the right to alter the specifications and contents of this bulletin without obligation or advance notice. All rights reserved. No part of this bulletin may be reproduced in any form or by any means, electronic or mechanical---including photocopying and recording and the use of any kind of information storage and retrieval system ---without permission in writing.

**MAZDA CONNECT Center Display View**

The rear-view monitor and Android Auto do not utilize all of the center display space.

Function	Display
<p>MAZDA CONNECT FM</p>	
<p>Apple CarPlay</p>	
<p>Android Auto</p>	
<p>Rear View Monitor</p>	

**CONSUMER NOTICE:** The information and instructions in this bulletin are intended for use by skilled technicians. Mazda technicians utilize the proper tools/equipment and take training to correctly and safely maintain Mazda vehicles. These instructions should not be performed by "do-it-yourselfers." Customers should not assume this bulletin applies to their vehicle or that their vehicle will develop the described concern. To determine if the information applies, customers should contact their nearest authorized Mazda dealership. Mazda North American Operations reserves the right to alter the specifications and contents of this bulletin without obligation or advance notice. All rights reserved. No part of this bulletin may be reproduced in any form or by any means, electronic or mechanical---including photocopying and recording and the use of any kind of information storage and retrieval system ---without permission in writing.



### In-Vehicle Digital Owner's Manual

The in-vehicle digital OM can be displayed on the center display while the vehicle is stopped. Customer can search descriptions and watch videos of vehicle features and functions by operating the commander switch.

**NOTE:**

1. The digital owner's manual must be installed during PDI. Due to printing deadlines and later updates to the digital manual, the content of the digital manual may differ from the printed manual.
2. USB memory flash drive FAT16 or FAT32 format is required for installation.
3. The vehicle's infotainment system will only accept file names [contents.tar] and [contents.sig]. File names with additional suffixes will not be accepted.
4. The infotainment system may inadvertently be powered OFF if the diagnostic assist function buttons are not pressed correctly. Simply press and hold the volume knob to power back ON.

**CONSUMER NOTICE:** The information and instructions in this bulletin are intended for use by skilled technicians. Mazda technicians utilize the proper tools/equipment and take training to correctly and safely maintain Mazda vehicles. These instructions should not be performed by "do-it-yourselfers." Customers should not assume this bulletin applies to their vehicle or that their vehicle will develop the described concern. To determine if the information applies, customers should contact their nearest authorized Mazda dealership. Mazda North American Operations reserves the right to alter the specifications and contents of this bulletin without obligation or advance notice. All rights reserved. No part of this bulletin may be reproduced in any form or by any means, electronic or mechanical---including photocopying and recording and the use of any kind of information storage and retrieval system ---without permission in writing.

Navigation System

2019 Mazda3 is not equipped with factory installed navigation system, however, it is available as a dealer installed accessory. **NOTE:** The 2019 Mazda3 accessory navigation SD is made in Japan instead of USA. If you use a made in the USA navigation SD card (for 6th gen) in the 2019 Mazda3, it will not function.



2019 Mazda3



Except 2019 Mazda3

SIRIUSXM Data Service No Free Trial (Preferred Package and above)

1. Only available as a paid subscription.
2. 2019 Mazda3 is not equipped with factory installed navigation system, however, it is available as a dealer installed accessory.
3. SiriusXM Traffic Plus feature requires in-vehicle navigation SD card.

See Owner's Manual -> Interior Features -> Mazda Connect -> Appendix

SA-007/19 - SIRIUSXM DATA SERVICES

**CONSUMER NOTICE:** The information and instructions in this bulletin are intended for use by skilled technicians. Mazda technicians utilize the proper tools/equipment and take training to correctly and safely maintain Mazda vehicles. These instructions should not be performed by "do-it-yourselfers." Customers should not assume this bulletin applies to their vehicle or that their vehicle will develop the described concern. To determine if the information applies, customers should contact their nearest authorized Mazda dealership. Mazda North American Operations reserves the right to alter the specifications and contents of this bulletin without obligation or advance notice. All rights reserved. No part of this bulletin may be reproduced in any form or by any means, electronic or mechanical---including photocopying and recording and the use of any kind of information storage and retrieval system ---without permission in writing.

Power Door Locks

Doors Lock With Keys In The Vehicle When Liftgate Lock Switch Is Pressed



DO NOT leave keys in the vehicle. The doors will lock with keys in the vehicle when liftgate lock switch is pressed and liftgate is closed, but the liftgate will not lock in the above condition.

**NOTE:** This is currently under investigation.



Doors cannot be unlocked using the outside door handle touch sensor  
The door handle touch sensor system may not operate normally under the following conditions:

1. Front passenger (without key) grabs and holds the outside door handle before the driver (with key) touches the drivers outside door handle unlock touch sensor.
2. You touch the sensing area of the door lock touch sensor and the sensing area of the door release touch sensor at the same time.

See Owner's Manual ->  
Before Driving -> Doors and Locks

Good	No Good

**CONSUMER NOTICE:** The information and instructions in this bulletin are intended for use by skilled technicians. Mazda technicians utilize the proper tools/equipment and take training to correctly and safely maintain Mazda vehicles. These instructions should not be performed by "do-it-yourselfers." Customers should not assume this bulletin applies to their vehicle or that their vehicle will develop the described concern. To determine if the information applies, customers should contact their nearest authorized Mazda dealership. Mazda North American Operations reserves the right to alter the specifications and contents of this bulletin without obligation or advance notice. All rights reserved. No part of this bulletin may be reproduced in any form or by any means, electronic or mechanical---including photocopying and recording and the use of any kind of information storage and retrieval system ---without permission in writing.

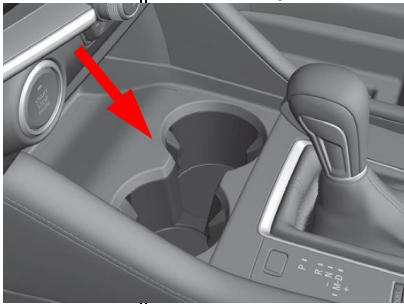
<p>Auxiliary Key</p> <p>The auxiliary keys need to be inserted into the transmitters during PDI.</p>	
<p>Auxiliary Key</p>  <p><b>NOTE:</b> The auxiliary keys are small and could be overlooked during PDI.</p>	<p>Transmitter</p> 
<p>Vehicles arrive at the dealer with Auxiliary Keys located in the glove compartment*</p> 	<p>Vehicles arrive at the dealer with Transmitters located in the front cup holder*</p>  <p style="text-align: right;">See Before Driving</p>
<p>* Vehicles that arrive at the dealer after business hours, transmitters/auxiliary keys are located in the dealer's early bird key drop box.</p>	
<ol style="list-style-type: none"> <li>1. If one auxiliary key is lost, some key machines can trace cut a new replacement key.</li> <li>2. If both auxiliary keys are lost, key machines cannot cut new replacement keys at this time.             <ol style="list-style-type: none"> <li>1. Key machines will not recognize the key code for these new keys.</li> <li>2. Mazda is aware of this issue and is working on a resolution.</li> </ol> </li> </ol> <p>Transmitter Note:</p> <ol style="list-style-type: none"> <li>1. If one transmitter is lost, inform the customer to take cautions not to lose the 2nd transmitter.</li> <li>2. If both transmitters are lost, the vehicle will be disabled.             <ol style="list-style-type: none"> <li>1. MDARS is not able to program transmitters at this time.</li> <li>2. Mazda is aware of this issue and is working on a resolution.</li> </ol> </li> </ol> <p>Insert the auxiliary key into the transmitter.</p>	

**CONSUMER NOTICE:** The information and instructions in this bulletin are intended for use by skilled technicians. Mazda technicians utilize the proper tools/equipment and take training to correctly and safely maintain Mazda vehicles. These instructions should not be performed by "do-it-yourselfers." Customers should not assume this bulletin applies to their vehicle or that their vehicle will develop the described concern. To determine if the information applies, customers should contact their nearest authorized Mazda dealership. Mazda North American Operations reserves the right to alter the specifications and contents of this bulletin without obligation or advance notice. All rights reserved. No part of this bulletin may be reproduced in any form or by any means, electronic or mechanical---including photocopying and recording and the use of any kind of information storage and retrieval system ---without permission in writing.

Remove the transmitter lower cover by sliding the knob in the direction shown and then sliding the cover in the opposite direction.



Insert the auxiliary key.

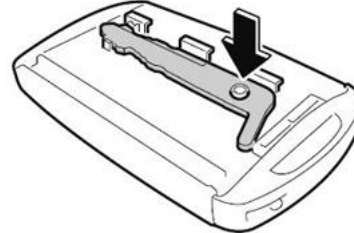

Install the transmitter lower cover by inserting the tabs of the lower cover into the slots of the transmitter.

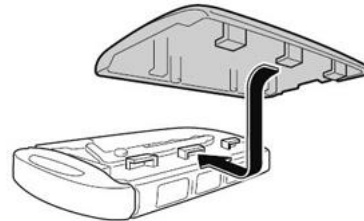

**CONSUMER NOTICE:** The information and instructions in this bulletin are intended for use by skilled technicians. Mazda technicians utilize the proper tools/equipment and take training to correctly and safely maintain Mazda vehicles. These instructions should not be performed by "do-it-yourselfers." Customers should not assume this bulletin applies to their vehicle or that their vehicle will develop the described concern. To determine if the information applies, customers should contact their nearest authorized Mazda dealership. Mazda North American Operations reserves the right to alter the specifications and contents of this bulletin without obligation or advance notice. All rights reserved. No part of this bulletin may be reproduced in any form or by any means, electronic or mechanical---including photocopying and recording and the use of any kind of information storage and retrieval system ---without permission in writing.

#### Transmitter Battery Saving Function (Key Fob)

The new 2019 Mazda3 has a "power saving" function built into the keyless entry system where some key fob functions are disabled. This feature could accidentally be enabled and some concerns with the vehicle may be:

1. Engine does not start.
2. Engine does not start unless you hold the fob to the start/stop button.
3. Doors do not unlock using the door handle, but unlock with the remote.
4. Doors do not lock using the door handle, but lock with the remote.
5. Transmitter indicator light does not turn on/flash.

#### Turning on the power saving function

After you have turned on the power saving function according to the following procedure, the hazard warning lights and sound operate\* one time.

1. Press the lock button on the transmitter 4 times within 3 seconds to turn on the operation indicator light.
2. Press the lock button continuously for 1.5 seconds or longer while the operation indicator light turns on (for 5 seconds).
3. Press any of the buttons on the transmitter to make sure that the operation indicator light does not turn on/flash.

#### Turning off the power saving function

After you have turned off the power saving function according to the following procedure, the hazard warning lights and sound operate\* one time.

1. Press any of the buttons on the transmitter to make sure that the operation indicator light does not turn on/flash.
2. Press the lock button on the transmitter 4 times within 3 seconds to turn on the operation indicator light.
3. Press the lock button continuously for 1.5 seconds or longer while the operation

**CONSUMER NOTICE:** The information and instructions in this bulletin are intended for use by skilled technicians. Mazda technicians utilize the proper tools/equipment and take training to correctly and safely maintain Mazda vehicles. These instructions should not be performed by "do-it-yourselfers." Customers should not assume this bulletin applies to their vehicle or that their vehicle will develop the described concern. To determine if the information applies, customers should contact their nearest authorized Mazda dealership. Mazda North American Operations reserves the right to alter the specifications and contents of this bulletin without obligation or advance notice. All rights reserved. No part of this bulletin may be reproduced in any form or by any means, electronic or mechanical---including photocopying and recording and the use of any kind of information storage and retrieval system ---without permission in writing.

indicator light turns on (for 5 seconds).

\*: with the advanced keyless function

Also see Owner's Manual -> Before Driving -> Keys -> Power saving function

**CONSUMER NOTICE:** The information and instructions in this bulletin are intended for use by skilled technicians. Mazda technicians utilize the proper tools/equipment and take training to correctly and safely maintain Mazda vehicles. These instructions should not be performed by "do-it-yourselfers." Customers should not assume this bulletin applies to their vehicle or that their vehicle will develop the described concern. To determine if the information applies, customers should contact their nearest authorized Mazda dealership. Mazda North American Operations reserves the right to alter the specifications and contents of this bulletin without obligation or advance notice. All rights reserved. No part of this bulletin may be reproduced in any form or by any means, electronic or mechanical---including photocopying and recording and the use of any kind of information storage and retrieval system ---without permission in writing.

**Keyless Entry Using Auxiliary Key**

If the vehicle battery is discharged and/or the key battery is dead, vehicle entry is possible using the auxiliary key.

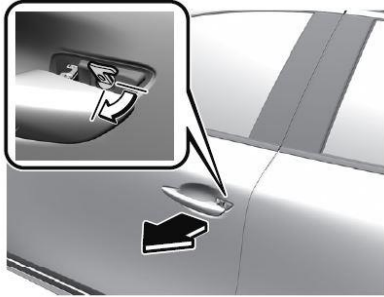

See Owner's Manual ->  
Before Driving -> Keys -> Auxiliary Key

Then refer to Owner's Manual ->  
Before Driving -> Doors and Locks  
-> Unlocking with Auxiliary Key

**Rear Door Child Safety Locks Operation**

The auxiliary key is required to enable (lock) and disable (unlock) the rear door child safety locks.

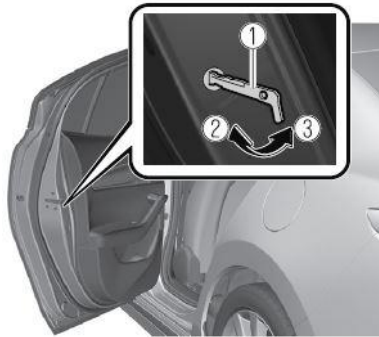

1. Auxiliary Key

2. Lock

3. Unlock

See Owner's Manual ->  
Before Driving -> Doors and Locks  
-> Rear Door Child Safety Locks

**CONSUMER NOTICE:** The information and instructions in this bulletin are intended for use by skilled technicians. Mazda technicians utilize the proper tools/equipment and take training to correctly and safely maintain Mazda vehicles. These instructions should not be performed by "do-it-yourselfers." Customers should not assume this bulletin applies to their vehicle or that their vehicle will develop the described concern. To determine if the information applies, customers should contact their nearest authorized Mazda dealership. Mazda North American Operations reserves the right to alter the specifications and contents of this bulletin without obligation or advance notice. All rights reserved. No part of this bulletin may be reproduced in any form or by any means, electronic or mechanical---including photocopying and recording and the use of any kind of information storage and retrieval system ---without permission in writing.



Seat Warmer and Heated Steering Wheel Auto Mode

The driver and front passenger's seater warmers\* and the heated steering wheel\* can be set to be automatically controlled (turned on and off) by the climate control system, depending on the set temperature.

Auto Mode

1. Go to MAZDA CONNECT home screen and select "Settings"
2. Select "Vehicle Settings".
3. Enable "Link Seat Climate Control Temperatures".
4. Press the climate control AUTO switch.

Link Seat Climate Control Temperatures Setting



Climate Control Auto Switch

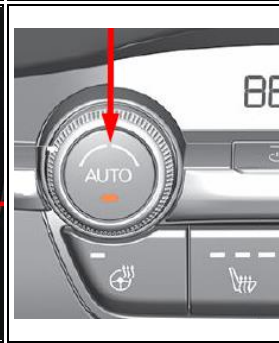

See Owner's Manual -> Essential Safety Equipment -> Seat Warmer/Heated Steering Wheel -> Seat Warmer / Heated Steering Wheel

\* if equipped

**CONSUMER NOTICE:** The information and instructions in this bulletin are intended for use by skilled technicians. Mazda technicians utilize the proper tools/ equipment and take training to correctly and safely maintain Mazda vehicles. These instructions should not be performed by "do-it-yourselfers." Customers should not assume this bulletin applies to their vehicle or that their vehicle will develop the described concern. To determine if the information applies, customers should contact their nearest authorized Mazda dealership. Mazda North American Operations reserves the right to alter the specifications and contents of this bulletin without obligation or advance notice. All rights reserved. No part of this bulletin may be reproduced in any form or by any means, electronic or mechanical---including photocopying and recording and the use of any kind of information storage and retrieval system ---without permission in writing.

Electric Parking Brake (EPB)

Parking Brake Auto Operation

When the ignition is switched OFF, the parking brake will be applied automatically. The EPB indicator light in the instrument cluster and the EPB switch indicator light turn ON.



1. Indicator light

Canceling the Parking Brake Auto Operation

Parking brake auto operation can be canceled using the procedure in the Owner's Manual.

**NOTE:** When the ignition is cycled back ON, the parking brake auto operation is restored.

Parking Brake Automatic Release

If the accelerator pedal is depressed with the parking brake applied and all of the following conditions are met, the parking brake is automatically release. When the parking brake is released, the EPB indicator light in the instrument cluster and the EPB switch indicator light turn off.

See Owner's Manual -> When Driving -> Brake -> EPB Auto operation

A/T	M/T	
Engine is running		
Driver's door is closed		
Driver's seat belt is fastened		
Selector lever is in the D, M, or R position	Shift lever is in a position other than neutral	
	Clutch pedal is depressed halfway	

**CONSUMER NOTICE:** The information and instructions in this bulletin are intended for use by skilled technicians. Mazda technicians utilize the proper tools/equipment and take training to correctly and safely maintain Mazda vehicles. These instructions should not be performed by "do-it-yourselfers." Customers should not assume this bulletin applies to their vehicle or that their vehicle will develop the described concern. To determine if the information applies, customers should contact their nearest authorized Mazda dealership. Mazda North American Operations reserves the right to alter the specifications and contents of this bulletin without obligation or advance notice. All rights reserved. No part of this bulletin may be reproduced in any form or by any means, electronic or mechanical---including photocopying and recording and the use of any kind of information storage and retrieval system ---without permission in writing.

A/C Air Temperature Is Not Cold

When diagnosing A/C performance complaints, use a thermometer as shown below and only compare A/C performance to another vehicle that is the same model/year/HVAC type\*.

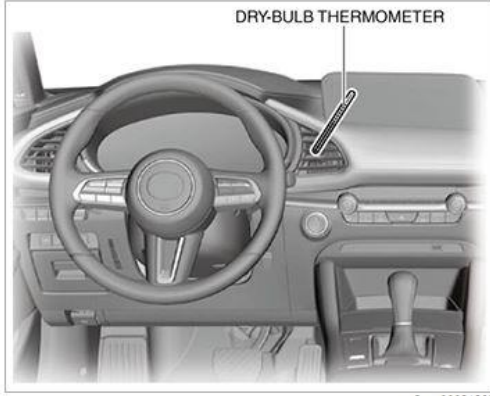

\*HVAC Types:

- 1. FULL-AUTO AIR CONDITIONER
- 2. MANUAL AIR CONDITIONER

MGSS: REFRIGERANT SYSTEM PERFORMANCE TEST [(US)]

Tire Pressure Monitoring System (TPMS) Change

The TPMS system uses a new rubber type direct TPMS.

**NOTE:** The new rubber type is not reusable. If the TPMS sensor is removed from the wheel, it must be replaced.



New Rubber Type

Old Metal Type

MGSS: TIRE PRESSURE MONITORING SYSTEM (TPMS)

**CONSUMER NOTICE:** The information and instructions in this bulletin are intended for use by skilled technicians. Mazda technicians utilize the proper tools/equipment and take training to correctly and safely maintain Mazda vehicles. These instructions should not be performed by "do-it-yourselfers." Customers should not assume this bulletin applies to their vehicle or that their vehicle will develop the described concern. To determine if the information applies, customers should contact their nearest authorized Mazda dealership. Mazda North American Operations reserves the right to alter the specifications and contents of this bulletin without obligation or advance notice. All rights reserved. No part of this bulletin may be reproduced in any form or by any means, electronic or mechanical---including photocopying and recording and the use of any kind of information storage and retrieval system ---without permission in writing.

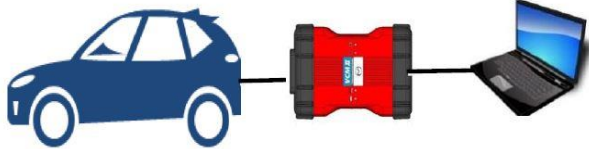
<p>Condition Based Maintenance (Except Canada) The vehicle calculates the maintenance (oil change) timing.</p> <ol style="list-style-type: none"> <li>1. This function cannot be turned OFF.</li> <li>2. Distance until the oil change is available in MAZDA CONNECT.</li> <li>3. <b>Reset is required after every oil change.</b></li> </ol>	<p>MGSS: MAINTENANCE MONITOR OPERATION PROCEDURE</p>
<p>New M-MDS (MDARS) A new M-MDS diagnostic tester (MDARS) for 7th generation vehicles (starting with the 2019 Mazda3) is used.</p> <ol style="list-style-type: none"> <li>1. Performs more maintenance service functions</li> <li>2. Performs more complicated vehicle electrical system diagnostic</li> <li>3. Reprograms more ECU's</li> </ol> 	<p>MGSS: BASIC KNOWLEDGE</p>
<p>Parts Replacement</p> <p>When replacing vehicle parts such as ECU's, motors, seats....etc, always refer to MGSS. Some new components may not operate if MGSS new part replacement procedure is not performed.</p>	<p>---</p>

**CONSUMER NOTICE:** The information and instructions in this bulletin are intended for use by skilled technicians. Mazda technicians utilize the proper tools/equipment and take training to correctly and safely maintain Mazda vehicles. These instructions should not be performed by "do-it-yourselfers." Customers should not assume this bulletin applies to their vehicle or that their vehicle will develop the described concern. To determine if the information applies, customers should contact their nearest authorized Mazda dealership. Mazda North American Operations reserves the right to alter the specifications and contents of this bulletin without obligation or advance notice. All rights reserved. No part of this bulletin may be reproduced in any form or by any means, electronic or mechanical---including photocopying and recording and the use of any kind of information storage and retrieval system ---without permission in writing.