

PREVOST

Instruction Sheet

IS-19913





BOSCH TO DELCO REMY ALTERNATOR INSTALLATION, US10 PREVOST

MATERIAL

Order Main Kit **IS19913**, which contains

Part No.	Description	Qty
0610086	Alternator Mechanical Kit, Right	1
0610088	Adaptation Kit, Right, Volvo 9700 / Prevost US10	1
IS-19913	Instruction Sheet	1
FI-19913	Feuille d'instructions	1



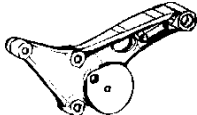
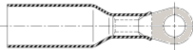

0610086 Alternator Mechanical Kit, Right

Part No.	Description		Qty
560720	Alternator Remy 55SI 24V-250A PadMount		1
069892	Pulley 8PK, 83 DOB		1
069894	Bracket, Alternator Remy		1
506065	Belt Poly V 8PK1435 EPDM QT+Aramide		2
5001308	SCR CAP HEXF N500 M10-1.5X40 G10.9		4
5002091	SCR CAP HEXF N500 M10-1.5X120 G10.9		4
5001137	WSH FL SS .203X.438X.06 (M5,#10)		2
5001180	NUT HEX NYRT SS 10-24		2
500411	WSH FL SS .260X.697X.05 (M6,1/4)		1
5001341	WSH FL SS 8.4X17X1.6 (M8,5/16)		1
500685	NUT HEX NYRT 5/16-18 SS		1

0610088 Adaptation Kit, Volvo 9700 / Prevost US10

Part No.	Description		Qty
012656	TENSIONNER SUPPORT, (NEEDS MINOR MODIFICATION)		1
0610034	Ground Cable		1
5001801	SCR CAP HEXF N500 M10-1.5X55 G10.9		2
500796	SCR CAP HEXF N500 M8 X 50 CL10.9		1
994445	FLANGE SCREW M8x16		1
N55439-02	RING TERMINAL 5MM / 16-14 / DURASEAL		3
N33509-06	Shrink tubing		12"











Other parts not provided in the kit; shop supplies

Part No.	Description		Qty
504016	CABLE TIE, 5/16" X 14"1/2		A/R
504751	MOUNT, TIE SWIVEL		A/R
507664	CABLE TIE, DOUBLE LOOP		A/R
509491	CABLE TIE, WIDE 13MM x 383MM		A/R
504637	CABLE TIE / 3/16" x 13"		A/R
684013	COLOR GUARD RUBBER COATING, 14.5 OZ CAN		A/R
680038	LOCTITE 243, BLUE,50ml		A/R
680100	LOCTITE 271, RED, 250ml		A/R
-	Brake cleaner		A/R

NOTE

Material can be obtained through regular channels.

TOOLS

<p>15/16" THIN WALL CROWFOOT ADAPTER.</p> 	<p>METRIC OPEN END WRENCH SET</p> 	<p>RATCHET AND SOCKET SET - METRIC</p> 
<p>HEX BIT SOCKET SET - METRIC</p> 	<p>TORQUE WRENCH</p> 	<p>SOFT FACED HAMMER</p> 
<p>1 5/8" OPEN END WRENCH</p> 	<p>BELT TENSION GAUGE</p> 	<p>1/2" SQUARE DRIVE BREAKER BAR</p> 
<p>VOLTMETER / MULTIMETER</p> 	<p>CUTTING PLIERS</p> 	

PROCEDURE



DANGER

Park vehicle safely, apply parking brake, stop engine. Prior to working on the vehicle, set the ignition switch to the OFF position and trip the main circuit breakers equipped with a trip button. On Commuter type vehicles, set the battery master switch (master cut-out) to the OFF position. Apply vehicle lockout procedures according to local policies.

Table of contents

OVERVIEW	4
ELECTRICAL SCHEMATICS	5
ALTERNATOR REMOVAL AND INSTALLATION	6
ALTERNATOR CONNECTIONS	10
FUNCTIONAL TESTING.....	16
LABOR REFERENCE TABLE	16

OVERVIEW

The procedure involves removing the existing Bosch alternators, their corresponding brackets and harnesses and replacing them with a DelcoRemy 55SI alternator.

The alternator requires new brackets and harnesses.

First time users should read the procedure before starting work on a vehicle. Best viewed in color.

ELECTRICAL SCHEMATICS

You may notice different *connector variants* between C397 (RJB) and the Bosch alternator connectors.

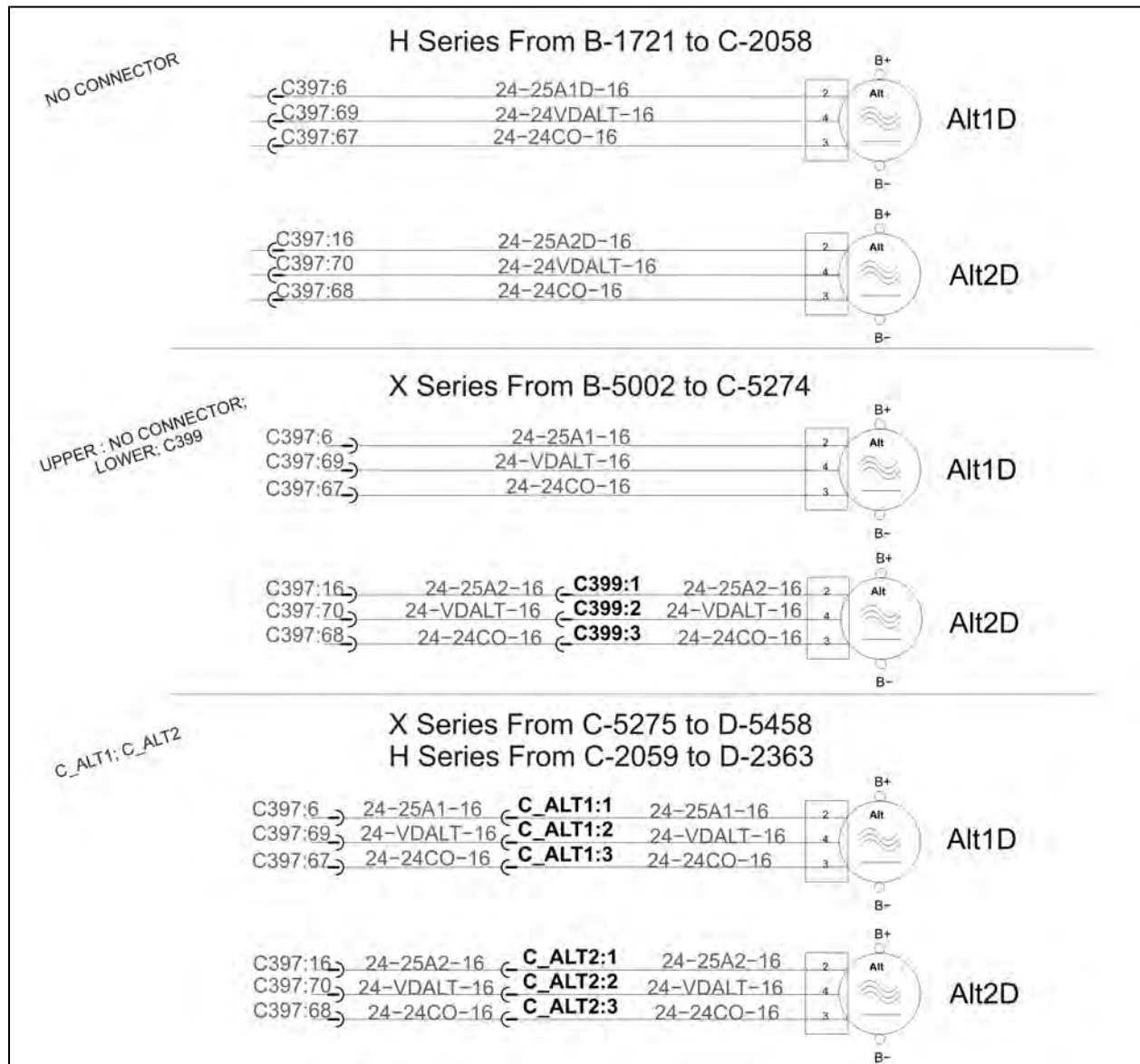

FIGURE 1: CONNECTOR VARIANTS, VINS PROVIDED FOR REFERENCE ONLY.

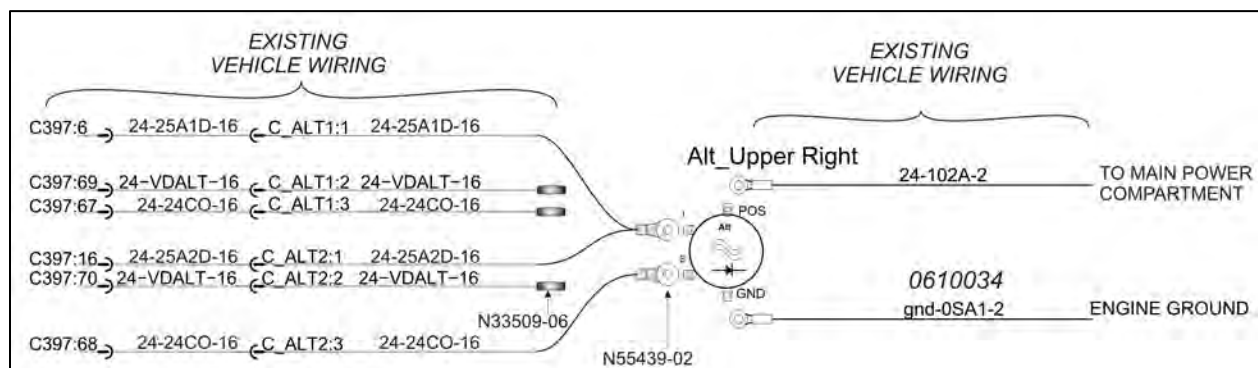

FIGURE 2: FINAL ALTERNATOR CONNECTIONS (LATE CONNECTOR VARIANT SHOWN)

ALTERNATOR REMOVAL AND INSTALLATION



WARNING

There should not be electrical power to the alternator terminals. Using a multimeter, probe the alternator **B1+** terminal and the ground terminal. Make sure that the voltage reading is 0 volt prior disconnecting the alternator cables.

1. Remove the alternator tensioner and mounting bracket.
Keep hardware and tensioner for re-use.
Discard bracket.



FIGURE 3

2. Remove the existing alternators. To do so, unscrew the four (4) mounting bolts identified on Figure 4. Discard bolts and alternators.
3. Also remove the idler at the bottom. Discard idler and hardware.

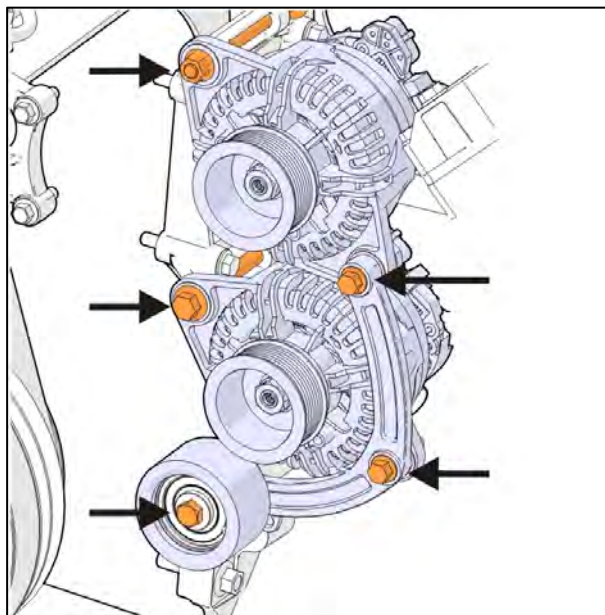

FIGURE 4

4. Remove the alternator support bolted on the engine. Discard support and bolts.

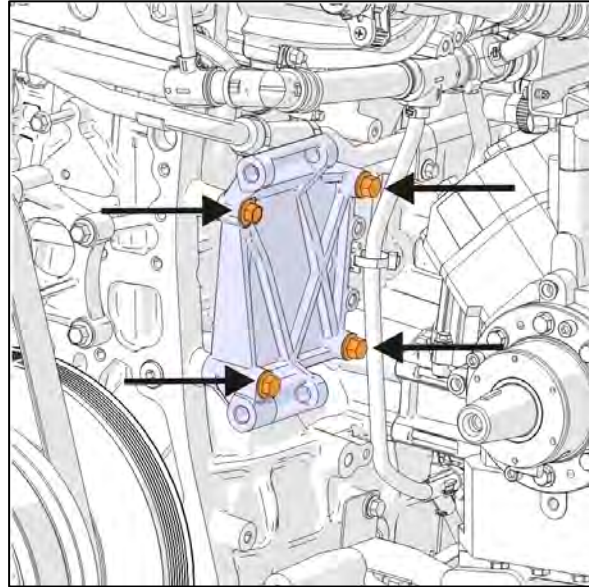

FIGURE 5

5. Under the alternators, remove the metal shield fixed to the engine support.



FIGURE 6

6. Installing the alternator pulley.

Place 560720 alternator flat on a bench with the shaft horizontal.

Required tools:

- 15/16" crowfoot adapter
- 8mm hex bit

Clean shaft and pulley with brake cleaner.

Slide pulley 069892 on shaft by hand.

Hand thread nut on shaft until snug.

Using 15/16" adapter and 8mm hex bit to block shaft rotation, tighten to **70-80 lb-ft.**

Apply torque seal

Never use power tools to install pulley and nut.

Note: Do not apply any pressure to end of the shaft. Internal damage may occur if the shaft is pushed back and turned.

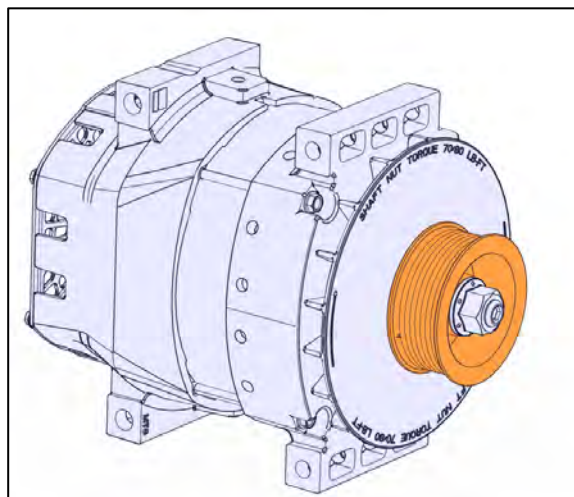

FIGURE 7

7. Install bracket 069894 on engine with four (4) 5001308 M10x40 bolts.

Apply blue Loctite 680038

Tighten to **35 lb-ft.**

Apply torque seal.

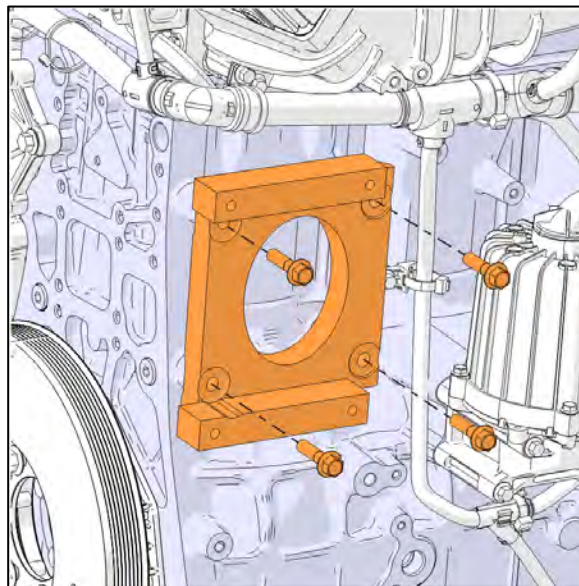

FIGURE 8

-
8. Install alternator on engine with four (4) 5002091 M10x120 bolts.
Apply blue Loctite 680038
Tighten to **48 lb-ft**
Apply torque seal.

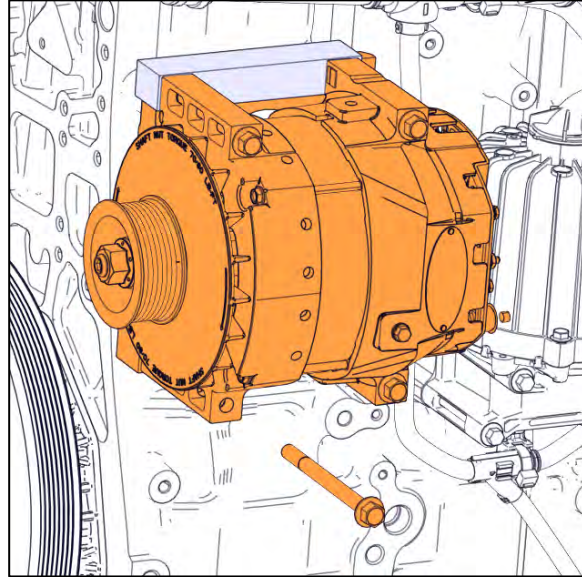

FIGURE 9

ALTERNATOR CONNECTIONS

9. Some wires will be used on the new installation. The other wires should be *sealed* with double wall heat shrink. Refer to ELECTRICAL SCHEMATICS.

Wire	Action
25A1 or 25A1D	Cut; Crimp 560082 ring terminal together with wire 25A2.
VDALT	<i>Cut; Heat shrink seal</i>
24CO	<i>Cut; Heat shrink seal</i>
25A2 or 25A2D	Cut; Crimp along with 25A1
VDALT	<i>Cut; Heat shrink seal.</i>
24CO	Cut; Crimp 560082 ring terminal.

10. Connect control wires.

Refer to ELECTRICAL SCHEMATICS.

Connect 24CO to *Sense*.

Connect 25A1/25A2 to *Indicator*.

Use 5001180 10-24 Nylon lock nuts and 5001137 washers.

Tighten to the following torque values:

Sense: 25-45 lb-in (3.0 5.0 N-m)

Indicator: 25-45 lb-in (3.0 5.0 N-m)

Apply color guard 684013 on connections.

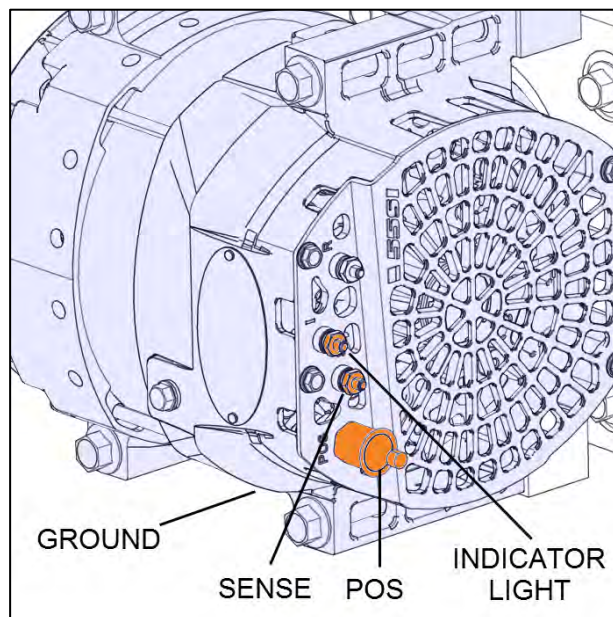

FIGURE 10

11. Identify with P-Touch type labels 25A1;
25A2; 24CO.



12. Secure wires with cable ties.

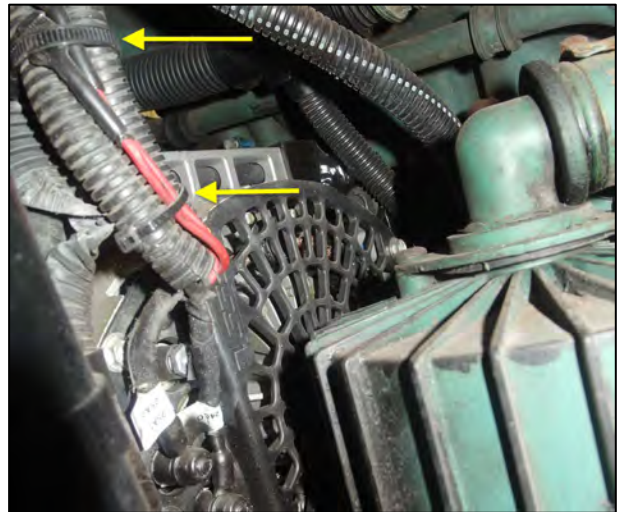

FIGURE 11

We must tilt the oil fill tube forward to provide clearance for the alternator cables.

13. Loosen the clamps on hose and support.
14. Pull hose forward.
15. Pull metal tube out.
16. We aim for a 10mm gap, minimum.

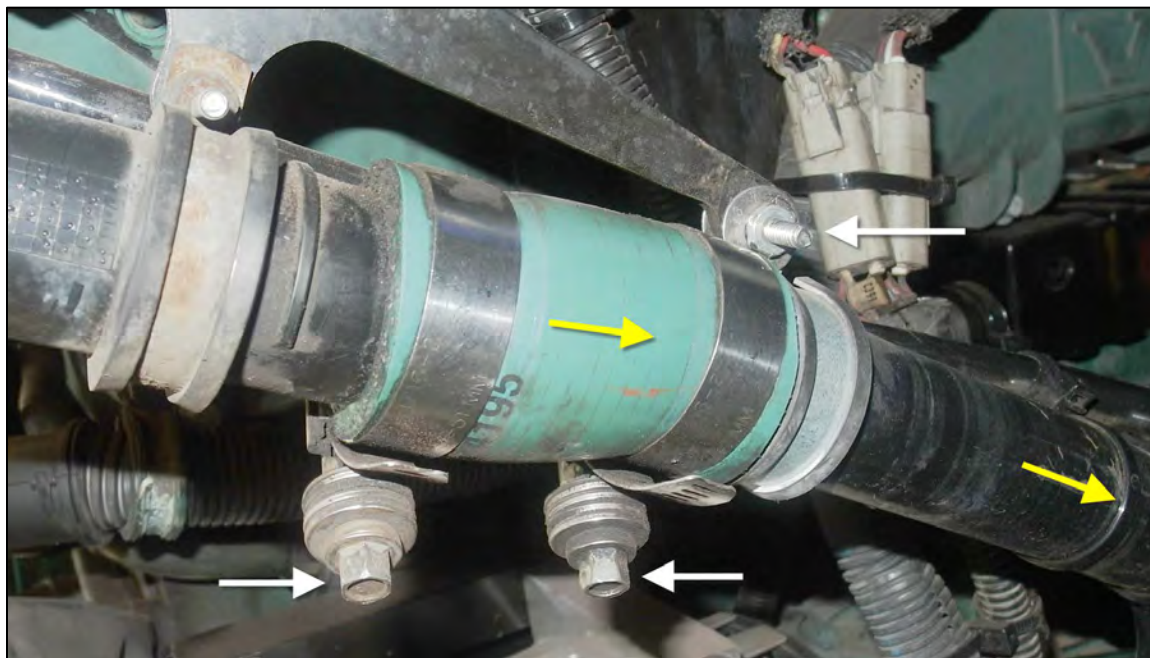

FIGURE 12

17. Install power cable on alternator. Reuse the existing cable.

See **NOTE** below

Use 500685, 5/16-18 nylon lock nut and 5001341, 8.4x17.0x1.6 SS washer.

Tighten to **80-125 lb-in (9.0-14.0 N-m)**

Apply color guard 684013 on connections.

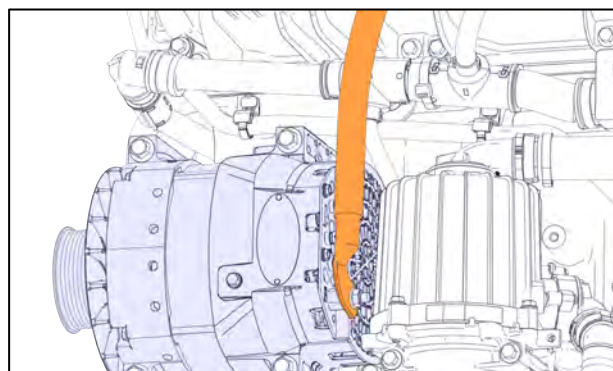

FIGURE 13

NOTE on positive stud :

Some early alternators have a shorter positive stud.

Nut 500685 does not thread fully on the shorter positive stud to allow the locking nylon lock to grip on the threads.

In this situation, use the *nut and lock washer* provided with the alternator.

Tighten to: **80-125 lb-in (9.0-14.0 N-m)**.

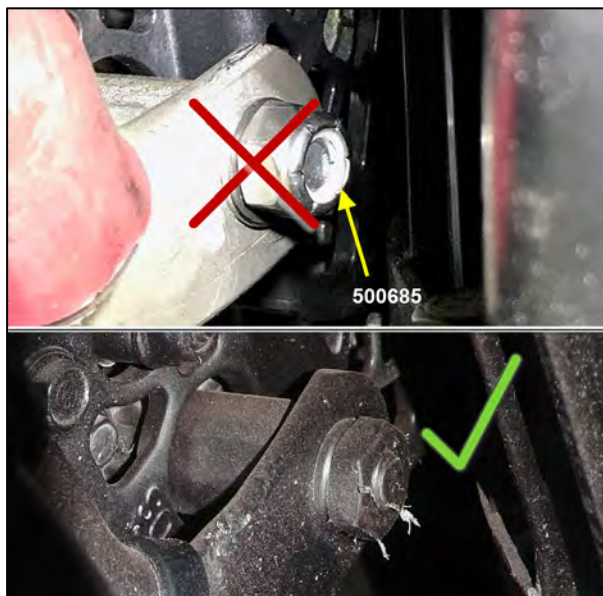

FIGURE 14: HARDWARE TO USE WITH SHORT STUD

18. Using a double loop cable tie 507664, and a swivel saddle tie mount 504751, create permanent space between the oil fill tube and the alternator cable at these two locations.

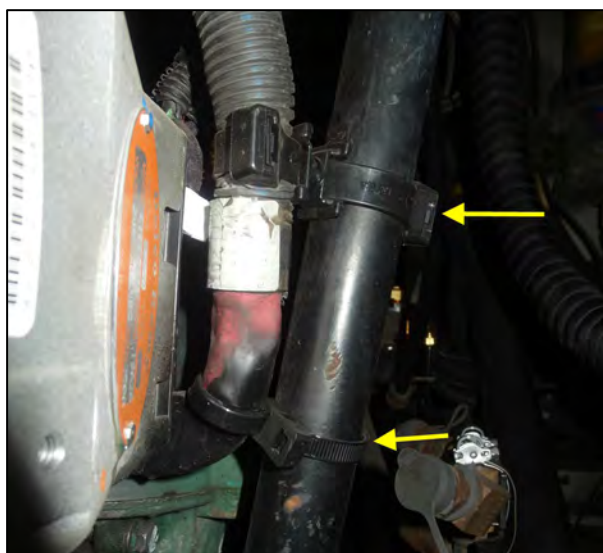

FIGURE 15

19. Prepare the alternator belt tensioner bracket 012656 by creating a relief on the back of the tensioner mounting pad to clear the alternator fan.

See image for dimensions.

Aim for a smooth surface finish and contour.

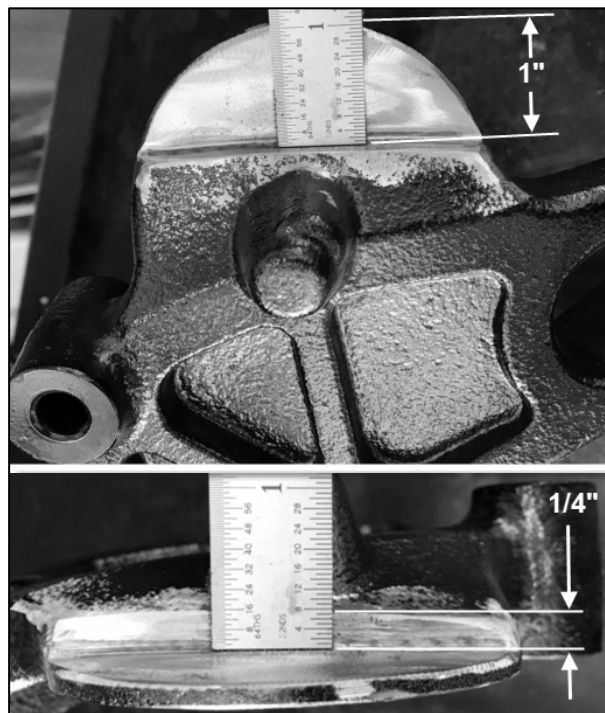
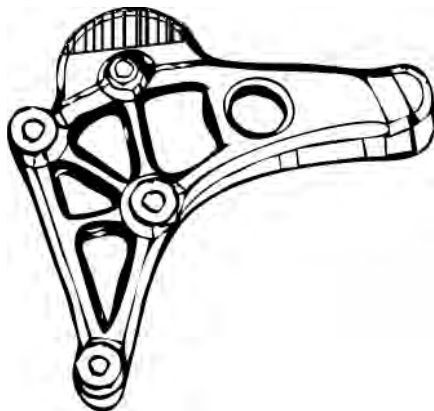

FIGURE 16

20. Install bracket on engine.

A: 500796, M8-1.25x50: **22 lb-ft**

B: 5001801, M10-1.5x55 (2x): **43 lb-ft**



FIGURE 17

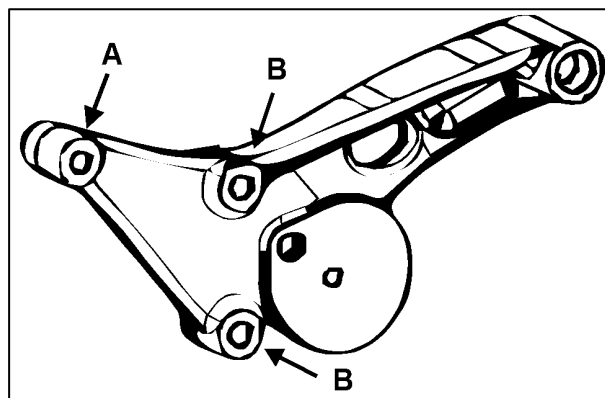

FIGURE 18

-
21. Install ground cable on alternator lower ground pad. Use 0610034 cable.

Add 500411.260x.697x.050 SS washer.

Ground: **50-60 lb-in (5.6-6.8 N-m)**

Apply color guard 684013 on connections.

22. Place ground cable on the engine ground.

Tighten to **240 lb-in.**

Apply color guard 684013 on connections.



FIGURE 19

-
23. Install the alternator belt tensioner with hardware reserved earlier.

Tighten to **48 lb-ft.**

Apply torque seal



FIGURE 20

-
24. Install alternator belt. To do so, rotate the automatic belt tensioner using a ½ square drive breaker bar



FIGURE 21

FUNCTIONAL TESTING

25. Reset main circuit breakers if applicable. Set the battery master switch (master cut-out) to the ON position and start the engine. Make sure that the charging system is working normally.

On the instruments cluster, the alternator telltale  illuminates if the alternators are not charging.

LABOR REFERENCE TABLE

Table for reference only.

Actual times will vary depending on vehicle condition.

	<i>Operation</i>	<i>Approximate labor (hours)</i>
Step 1	BOSCH ALTERNATORS REMOVAL, RIGHT HAND SIDE	1h
Step 2	INSTALLING THE RIGHT HAND ALTERNATOR. (includes wiring)	2h
Step 3	FUNCTIONAL TESTING	0.5h
	Total	3.5 hours

PARTS / WASTE DISPOSAL

Discard waste according to applicable environmental regulations (Municipal/State[Prov.]/ Federal)