

CVT Hiss Noise Valve Body Replacement

Service Category Drivetrain

Section Automatic Transmission/Transaxle

Market USA

Scion Supports ASE Certification 

Applicability

YEAR(S)	MODEL(S)	ADDITIONAL INFORMATION
2016	iM	

Introduction

Some 2016 model year iM vehicles equipped with the K313 Continuously Variable Transaxle (CVT) may exhibit a high-pitched hiss or whine noise after the vehicle has reached normal operating temperature. This condition may be caused by the valve body plate inside the CVT assembly. Follow the Repair Procedure in this bulletin to address this condition.

Production Change Information

NOTE
 Reference the CVT serial number information below to identify if the CVT was produced BEFORE the implemented production change.

1. Locate the CVT serial number.
 The CVT serial number is stamped on the case as shown.

Figure 1. K313 CVT Serial Number Location

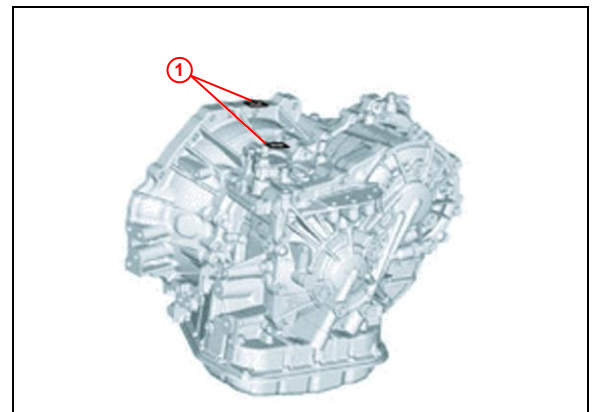

1	CVT Serial Location
----------	----------------------------

CVT Hiss Noise Valve Body Replacement

Production Change Information (continued)

2. Reference the serial decoder below for the CVT.

Figure 2. TMH Produced K313 Serial Decoder

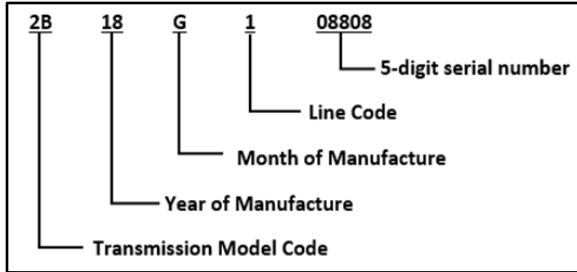
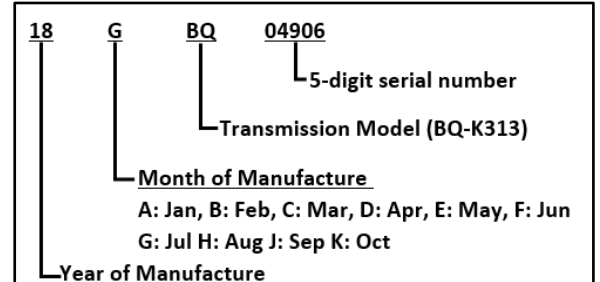

Figure 3. Aisin AW Produced K313 Serial Decoder



This bulletin applies to vehicles produced **BEFORE** the Production Change Effective Serial Numbers shown below.

CVT MANUFACTURER	PRODUCTION LINE	PRODUCTION CHANGE EFFECTIVE SERIAL NUMBER
Aisin AW	–	18GBQ4906
Toyota Motor Hokkaido (TMH)	1	2B18G108808
	2	2B18G206410
	3	2B18G307308

Warranty Information

OP CODE	DESCRIPTION	TIME	OFF	T1	T2
TC1901	R & R CVT Valve Body Assembly	3.1	35410-12871	91	99

APPLICABLE WARRANTY

- This repair is covered under the Toyota Powertrain Warranty. This warranty is in effect for 60 months or 60,000 miles, whichever occurs first, from the vehicle's in-service date.
- Warranty application is limited to occurrence of the specified condition described in this bulletin.

CVT Hiss Noise Valve Body Replacement

Parts Information

PART NUMBER	PART NAME	QTY
35410-12871	Body Assy, Transmission Valve	1
35168-12091	Gasket, Transaxle Oil Pan	1
35145-07010	Gasket, Transaxle Case	1
90301-22019	Ring, O	1
90301-06004		1
08886-02505	ATF CVT FE (4-Liter Can)	2*

*This Repair Procedure requires approximately 6 L of CVT fluid.

Required Tools & Equipment

REQUIRED EQUIPMENT	SUPPLIER	PART NUMBER	QTY
Techstream 2.0*	ADE	TS2UNIT	1
Techstream Lite		TSLITEPDLR01	
Techstream Lite (Green Cable)		TSLP2DLR01	

*Essential SST.

NOTE

- Only ONE of the Techstream units listed above is required.
- Software version 13.30.018 or later is required.
- Additional Techstream units may be ordered by calling Approved Dealer Equipment (ADE) at 1-800-368-6787.

SPECIAL SERVICE TOOLS (SST)	PART NUMBER	QTY
Diagnosis Check Wire 2*	09843-18040	1

*Essential SST.

NOTE

Additional SSTs may be ordered by calling 1-800-933-8335.

CVT Hiss Noise Valve Body Replacement

Diagnosis

1. Turn the vehicle ON.

2. In Park or Neutral with the engine running, allow the vehicle to sit for 15 – 20 minutes to reach normal operating temperature.
 - A. Lower the driver's side window.
 - B. Test-drive the vehicle.
 - C. Listen for a hissing noise. Refer to the video link below for an example of this condition.

[Example of Hissing Noise](#)

Is a hissing noise similar to the example present?

- **YES** — Continue to the Repair Procedure to replace the CVT valve body assembly.
- **NO** — This bulletin does NOT apply. Continue diagnosis using the applicable Repair Manual.

CVT Hiss Noise Valve Body Replacement

Repair Procedure (continued)

Valve Body Removal

Figure 4. Valve Body Location

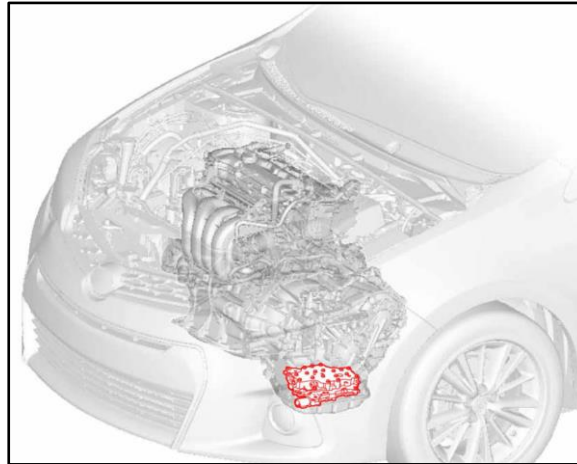

NOTICE

- TO PREVENT CONTAMINATION, DO NOT CLEAN THE CVT CASE.
- Perform work when it can be done without interruption to prevent foreign materials or dust from entering the transmission.
- Prepare a clean work environment BEFORE initiating work.
- Do NOT contaminate the CVT with debris and dust.
- Do NOT use a shop cloth, a paper shop cloth, or cotton gloves.
- Do NOT perform work in close proximity to others using compressed air guns.

NOTE

Do NOT open the package of the NEW transmission valve body assembly until IMMEDIATELY BEFORE replacement.

1. Remove the CVT fluid.

Refer to the TIS, applicable model and model year Repair Manual:

- 2016 iM:
Drivetrain – CVT – [“K313 CVT: Continuously Variable Transaxle Fluid: Replacement”](#)

2. Remove the drain plug and gasket from the CVT oil pan sub-assembly.

CVT Hiss Noise Valve Body Replacement

Repair Procedure (continued)

Valve Body Removal (continued)

- Remove ALL 16 bolts, the CVT oil pan sub-assembly, and the CVT oil pan gasket from the CVT assembly.

NOTE

Remove the CVT oil pan sub-assembly with care as some fluid will remain in the CVT oil pan sub-assembly.

Figure 5. CVT Oil Pan Bolts

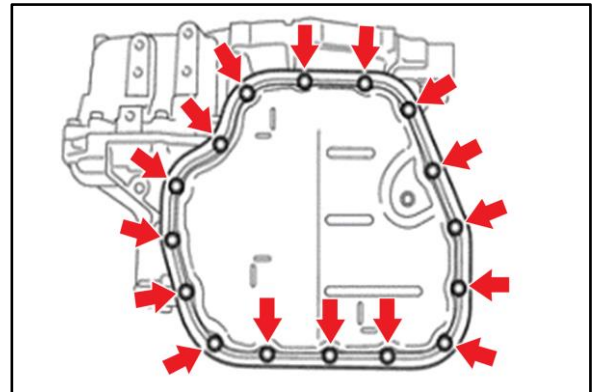

- Remove the CVT oil pan gasket from the CVT oil pan sub-assembly. Wash away ANY metal contaminants and sludge deposited inside the CVT oil pan sub-assembly by using NEW CVT fluid.

NOTICE

- Lightly clean as needed to prevent contamination.
- Do NOT use brake cleaner.
- It is NOT required to remove the metal contaminants attached to the magnet.

- Unscrew the three bolts and remove the oil strainer from the transmission valve body assembly.

Bolt A Length: 16 mm (2)

Bolt B Length: 25 mm (1)

NOTE

Additional CVT fluid will flow out during oil strainer removal.

Figure 6. Oil Strainer

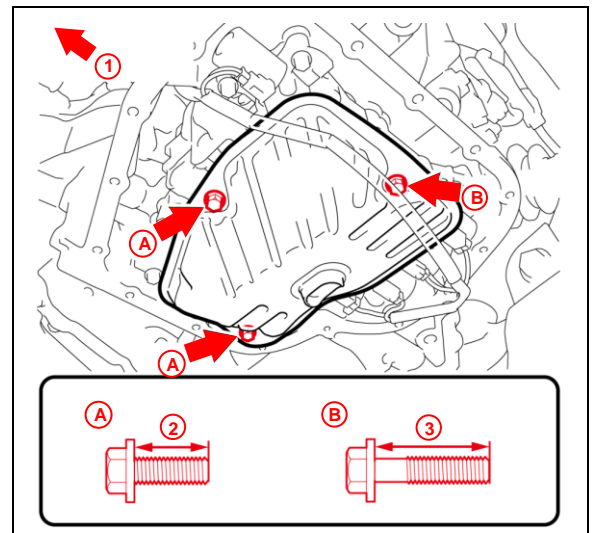

1	Front of Vehicle
2	16 mm Bolt
3	25 mm Bolt

CVT Hiss Noise Valve Body Replacement

Repair Procedure (continued)

Valve Body Removal (continued)

6. Remove the O-ring from the oil strainer.

NOTE

Make sure there is no contamination on the oil strainer.

Figure 7. Oil Strainer O-ring Removal

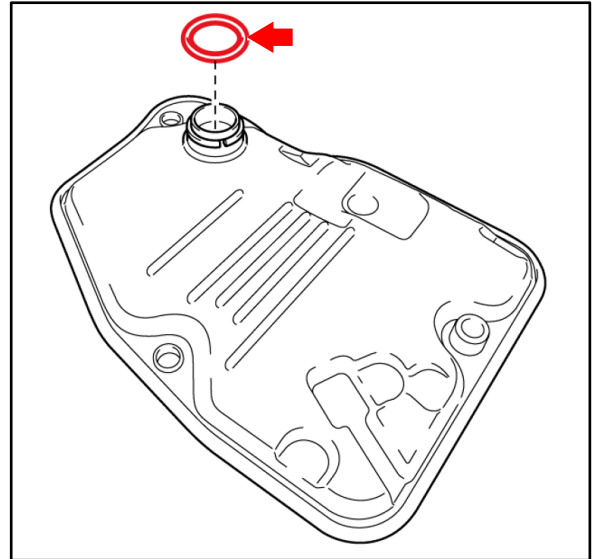

7. Remove the transmission harness.
 - A. Disconnect the five valve body connectors of the transmission harness from the transmission valve body assembly.

NOTE

Do NOT remove the respective solenoid valves from the transmission valve body.

Figure 8. Valve Body Connectors

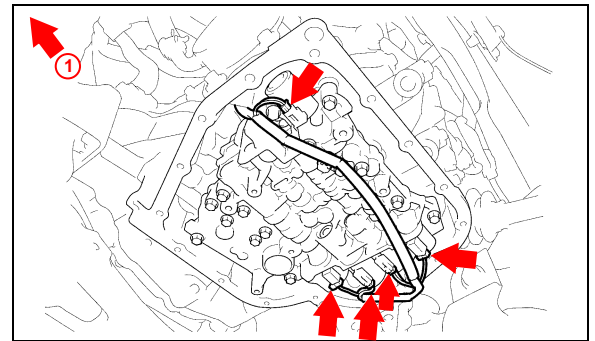

1

Front of Vehicle

CVT Hiss Noise Valve Body Replacement

Repair Procedure (continued)

Valve Body Removal (continued)

- (1) Apply the needle-nose plier end to the male connector tab.
- (2) Gently hold the needle-nose plier and push the male connector tab out.

NOTICE
Remove the connector as shown to avoid breakage.

Figure 9. Valve Body Connectors

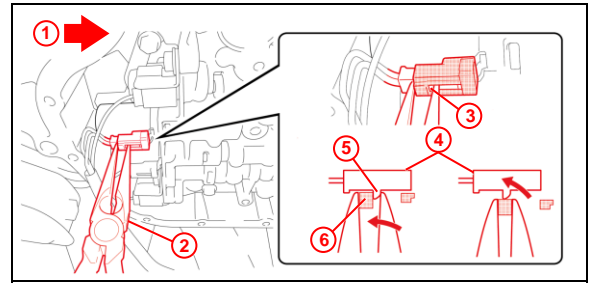

1	Front of Vehicle
2	Needle-nose Plier
3	Claw Portions
4	Male Connector Tab
5	Male Connector Claw
6	Female Connector Lock

- (3) Remove the male connector.

Figure 10. Connector Removal

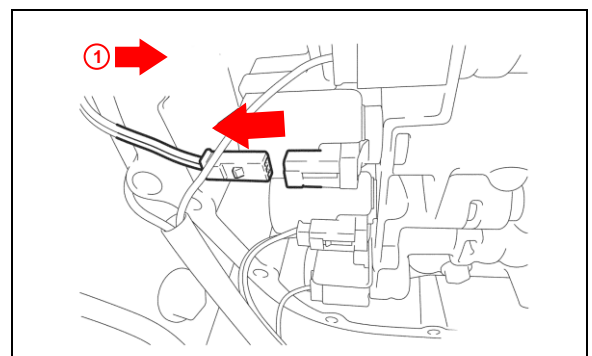

1	Front of Vehicle
----------	-------------------------

CVT Hiss Noise Valve Body Replacement

Repair Procedure (continued)

Valve Body Removal (continued)

8. Remove the bolt and oil temperature sensor clamp.
9. Remove the oil temperature sensor.

NOTE

Additional CVT fluid will flow out during oil temperature sensor removal.

Figure 11. Temperature Sensor Location

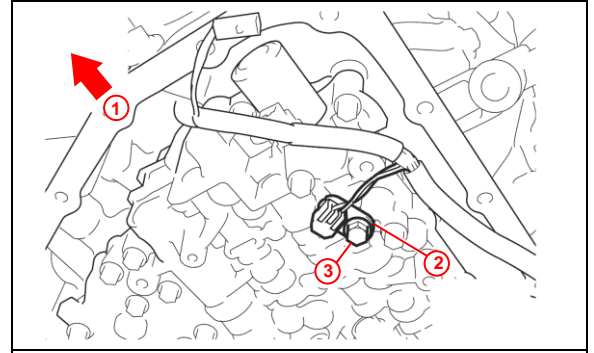

1	Front of Vehicle
2	Oil Temperature Sensor Clamp
3	Temperature Sensor Bracket Bolt

10. Remove the O-ring from the oil temperature sensor.

Figure 12. O-Ring Removal

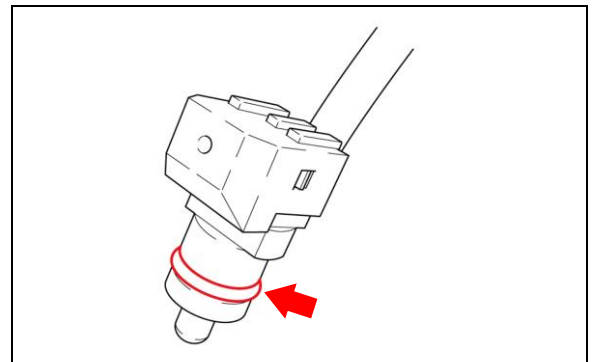

CVT Hiss Noise Valve Body Replacement

Repair Procedure (continued)

Valve Body Removal (continued)

- Unscrew the 13 bolts and remove the transmission valve body assembly from the transmission case.

Bolt A Length: 20 mm (2)

Bolt B Length: 35 mm (7)

Bolt C Length: 45 mm (4)

NOTE

- The fluid may flow out for a few minutes AFTER removing the transmission valve body.
- The transmission valve body weighs approximately 4.6 kg.

Figure 13.

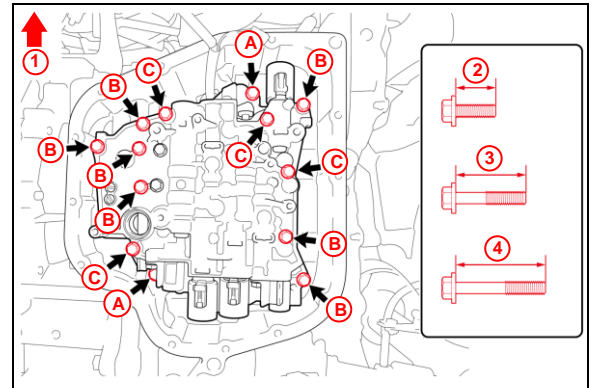

1	Front of Vehicle
2	20 mm Bolt
3	35 mm Bolt
4	45 mm Bolt

- Remove the CVT case gasket from the transmission case.

NOTICE

Continue to Valve Body Installation IMMEDIATELY and without ANY interruption to avoid contamination.

Figure 14. CVT Case Gasket

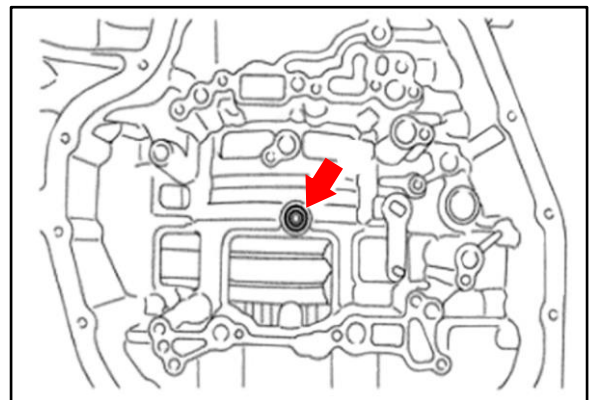

CVT Hiss Noise Valve Body Replacement

Repair Procedure (continued)

Valve Body Installation

13. Apply a small amount of Toyota Genuine MP Grease No. 2 (or equivalent) to the NEW CVT case gasket.

Figure 15. Gasket Grease Application

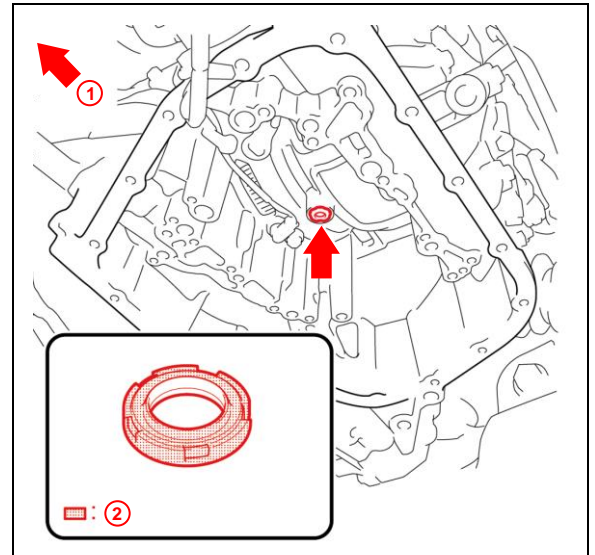

1	Front of Vehicle
2	Grease Application Location

14. Install the gasket to the transmission case.

NOTE
The CVT case gasket is nondirectional.

NOTICE
Make sure the CVT case gasket is properly installed to the transmission case to prevent it from falling off.

CVT Hiss Noise Valve Body Replacement

Repair Procedure (continued)

Valve Body Installation (continued)

15. Remove the manual valve as shown in Figure 17.

NOTICE

- Carefully fit the **NEW** transmission valve body assembly into the transmission case.
- Make sure not to damage the top of the sub strainers positioned at the back of the transmission body assembly.
- Hold the **NEW** transmission valve body assembly horizontally to prevent the manual valve from falling off.

Figure 16. Valve Body Sub Strainer

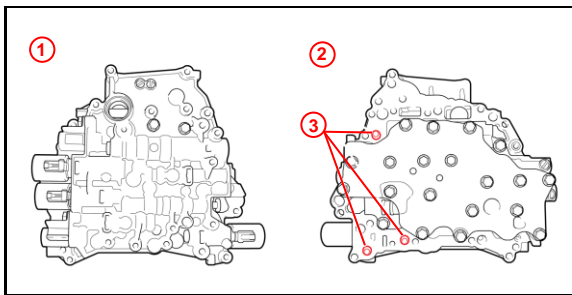

1	Front View
2	Back View
3	Sub Strainer

Figure 17. Manual Valve Position

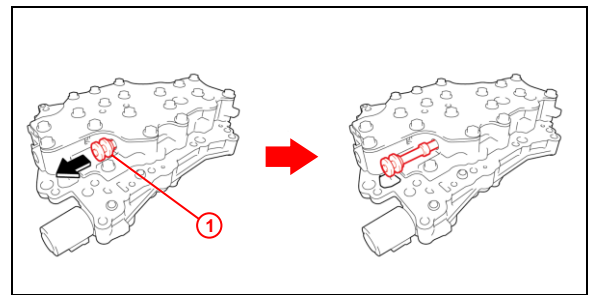

1	Manual Valve
----------	---------------------

16. Match the position of the holes of the **NEW** transmission valve body assembly and hold the valve body assembly horizontally.

17. Make sure the projection of the manual valve lever sub-assembly and the groove of the manual valve are matching as shown.

NOTE

If the projection does NOT match the groove, relocate the manual valve.

Figure 18. Valve Body Installation

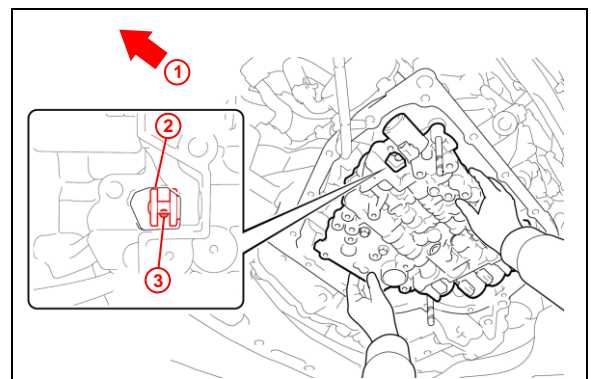

1	Front of Vehicle
2	Manual Valve
3	Projection of Manual Lever Sub-Assembly

18. Push to install the **NEW** transmission valve body assembly to the transmission case and hold it in place.

CVT Hiss Noise Valve Body Replacement

Repair Procedure (continued)

Valve Body Installation (continued)

19. Holding the transmission valve body assembly, install the two bolts as shown.

Bolt B Length: 35 mm (2)

NOTE

Make sure to begin torquing from the two bolts shown as they will be the installation position standard.

20. Temporarily tighten the bolts manually until they sit properly on the transmission valve body assembly.

21. Temporarily tighten the remaining 11 bolts manually until they sit properly.

Bolt A Length: 20 mm (2)

Bolt B Length: 35 mm (5)

Bolt C Length: 45 mm (4)

Figure 19. Valve Body Installation

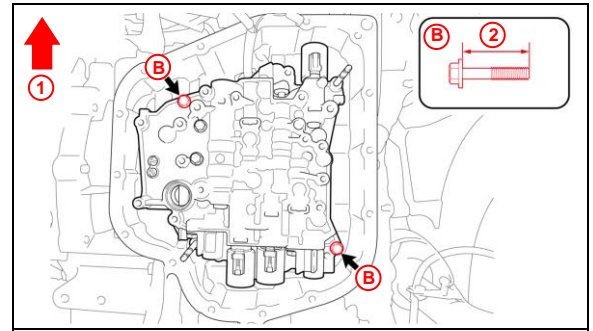

1	Front of Vehicle
2	35 mm Bolt

Figure 20. Valve Body Installation

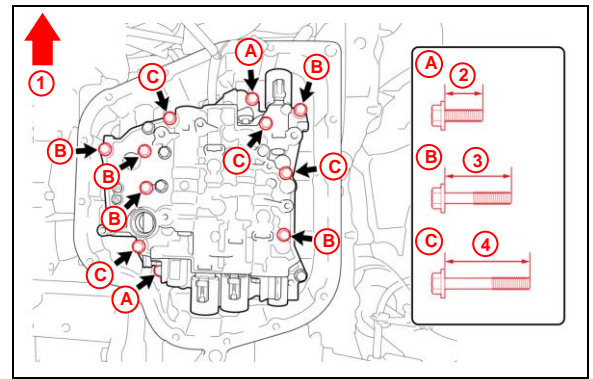

1	Front of Vehicle
2	20 mm Bolt
3	35 mm Bolt
4	45 mm Bolt

CVT Hiss Noise Valve Body Replacement

Repair Procedure (continued)

Valve Body Installation (continued)

22. Tighten the two bolts.

Torque: 10.8N*m (110kgf*cm, 8ft*lbf)

NOTE

Every time a bolt is tightened, clean the bolt head and put a yellow paint mark on it.

Figure 21. Valve Body Installation

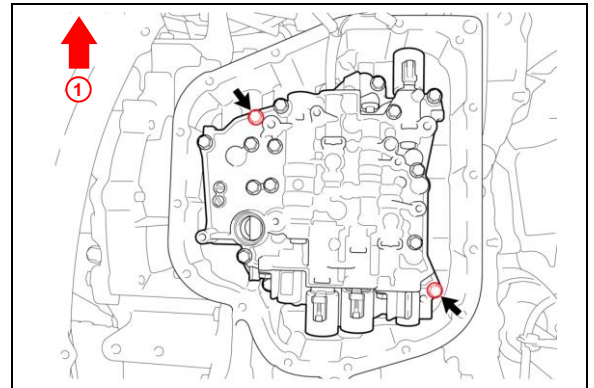

1	Front of Vehicle
----------	-------------------------

23. Evenly tighten the other 11 bolts.

Torque: 10.8N*m (110 kgf*cm,8 ft.lbf)

NOTE

Every time a bolt is tightened, clean the bolt head and put a yellow paint mark on it.

Figure 22. Valve Body Installation

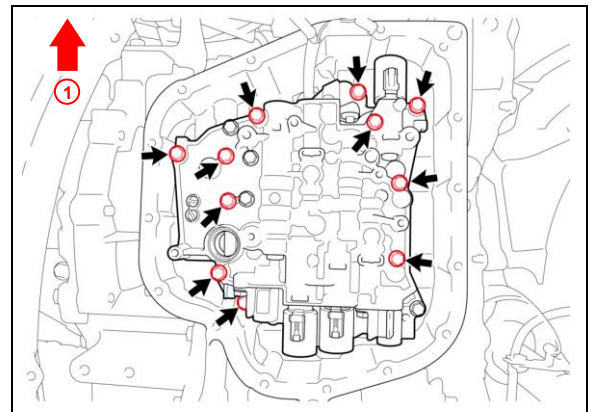

1	Front of Vehicle
----------	-------------------------

CVT Hiss Noise Valve Body Replacement

Repair Procedure (continued)

Valve Body Installation (continued)

24. Reinstall the transmission harness.
Apply Toyota Genuine CVT Fluid to the NEW O-ring and fit it to the oil temperature sensor.

Figure 23. CVT Fluid Application Area

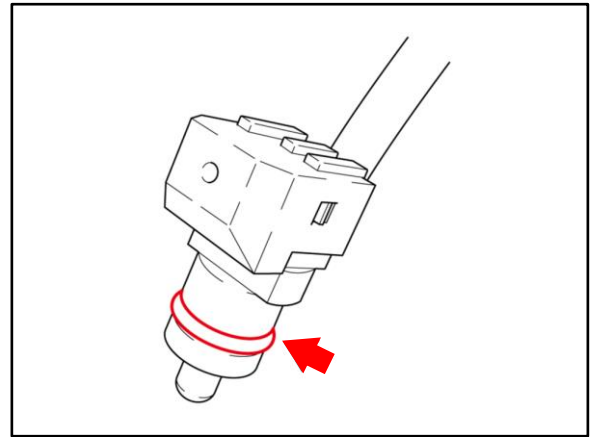

25. Reinstall the temperature sensor as shown.
26. Reinstall the oil temperature sensor clamp with the bracket bolt.
Torque: 10.8N*m (110kgf*cm,8ft.*lbf)

Figure 24. Temperature Sensor Installation

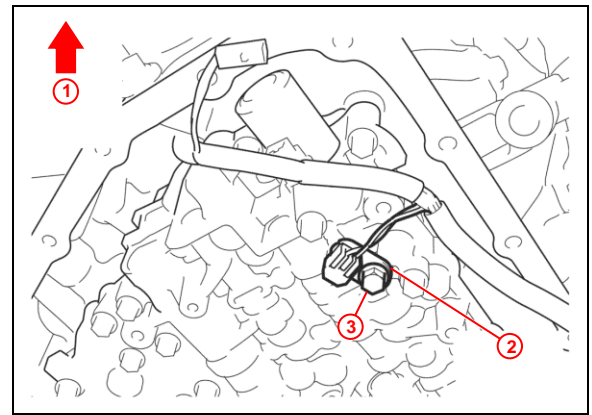

1	Front of Vehicle
2	Clamp
3	Temperature Sensor Bracket Bolt

CVT Hiss Noise Valve Body Replacement

Repair Procedure (continued)

Valve Body Installation (continued)

27. Reconnect the five connectors and install the transmission harness to the transmission valve.

NOTICE

- Make sure to install each connector in the position shown.
- Incorrect connector installation may lead to CVT assembly malfunction or replacement.

Figure 25. CVT Wiring Harness Installation

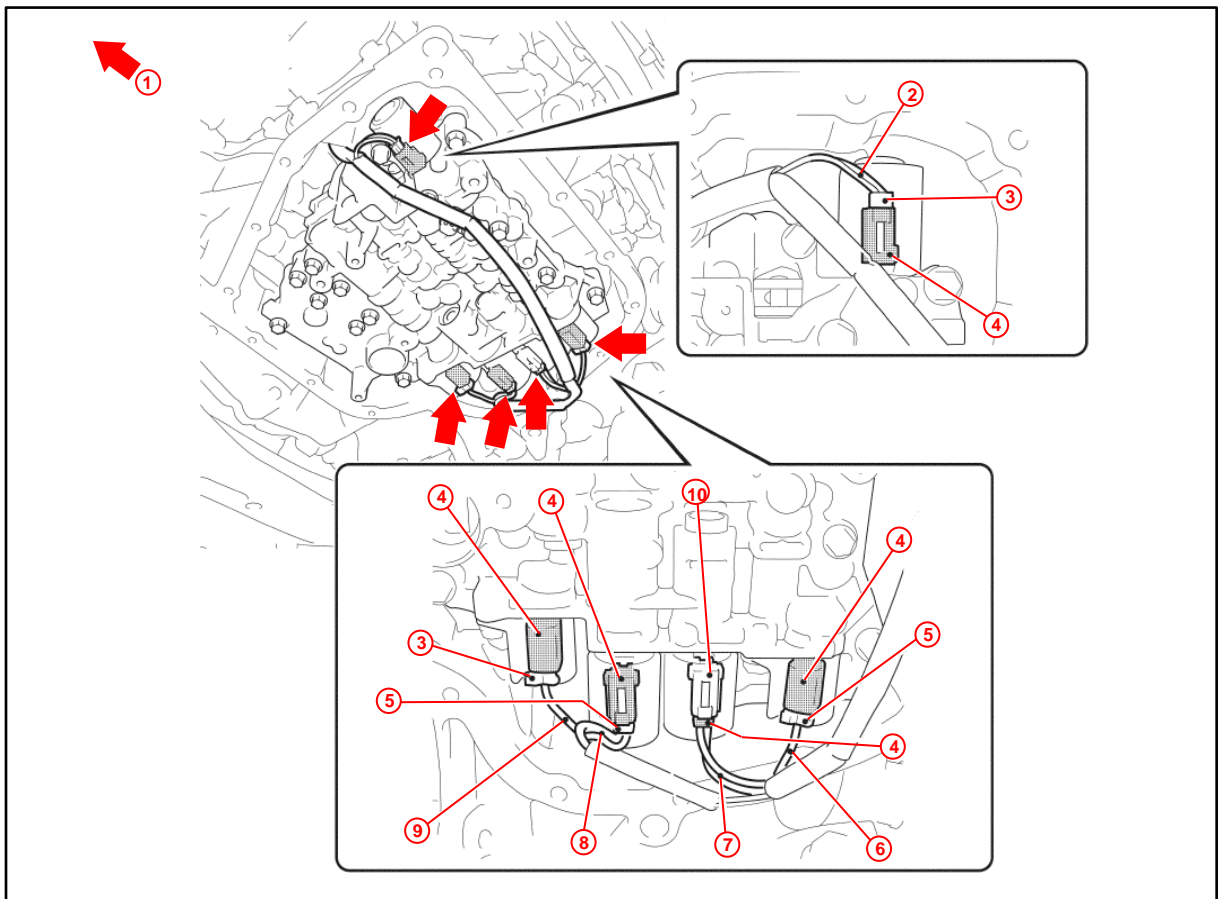

1	Front of Vehicle
2	Yellow/Light Green
3	White
4	Black
5	Green

6	Light Blue
7	Blue/Red
8	White/Black
9	Purple
10	Blue

CVT Hiss Noise Valve Body Replacement

Repair Procedure (continued)

Valve Body Installation (continued)

28. Perform an intermediate inspection to confirm the following:
 - A. The projection of the manual valve lever sub-assembly is properly matched to the groove of the manual valve. (See callout A in the figure below.)
 - B. The connector is installed at the proper position. (See callout B in in the figure below.)
 - C. Each of the 13 bolt heads has a yellow paint mark, indicating complete tightening. (See callout C in the figure below.)

Figure 26. Inspection of Valve Body Assembly

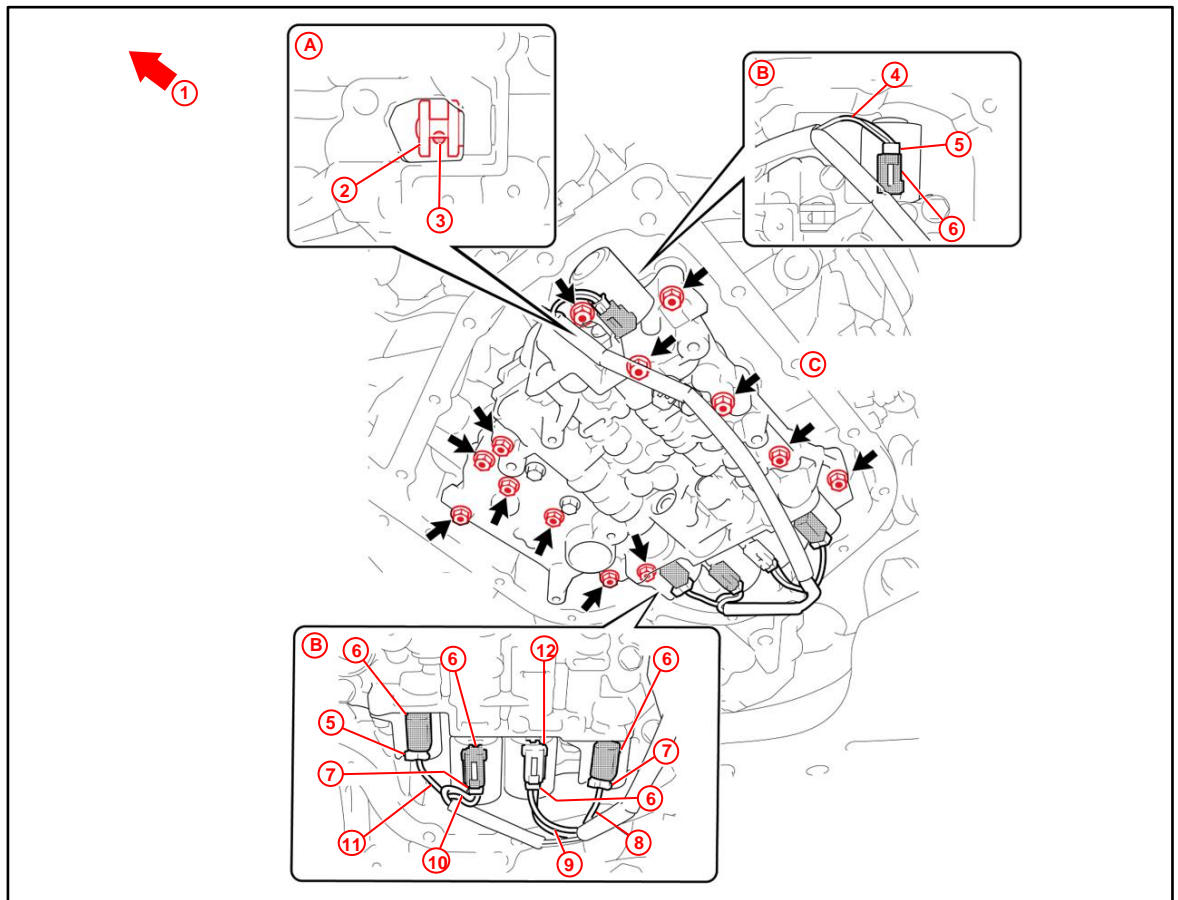

1	Front of Vehicle
2	Manual Valve
3	Projection of Manual Lever Sub-Assembly
4	Yellow/Light Green
5	White
6	Black

7	Green
8	Light Blue
9	Blue/Red
10	White/Black
11	Purple
12	Blue

CVT Hiss Noise Valve Body Replacement

Repair Procedure (continued)

Valve Body Installation (continued)

29. Reinstall the oil strainer.
Apply Toyota Genuine CVT Fluid to the NEW O-ring and then fit it onto the oil strainer.

Figure 27. O-Ring Installation

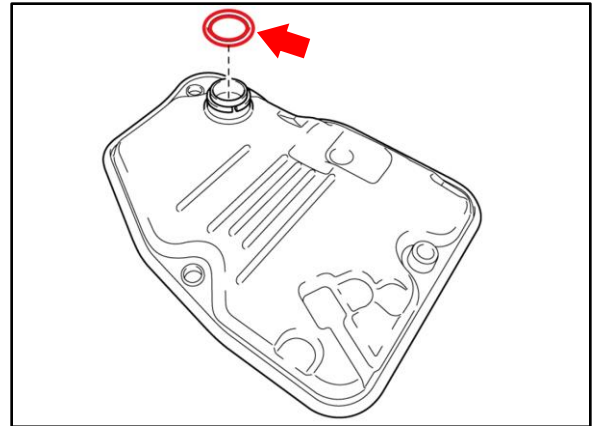

30. Temporarily and evenly tighten the three bolts to prevent distortion.

31. Temporarily reinstall the oil strainer to the transmission valve body assembly.

Bolt A Length: 16 mm (2)

Bolt B Length: 25 mm (1)

NOTE

- When installing the oil strainer to the transmission valve body assembly, prevent the O-ring from getting caught.
- Apply pressure to the area below Bolt A at the 12 o'clock position (as shown) while keeping the strainer level.
- Prevent the transmission wiring from getting caught between the transmission valve body assembly and the oil strainer.

Figure 28. Oil Strainer Installation

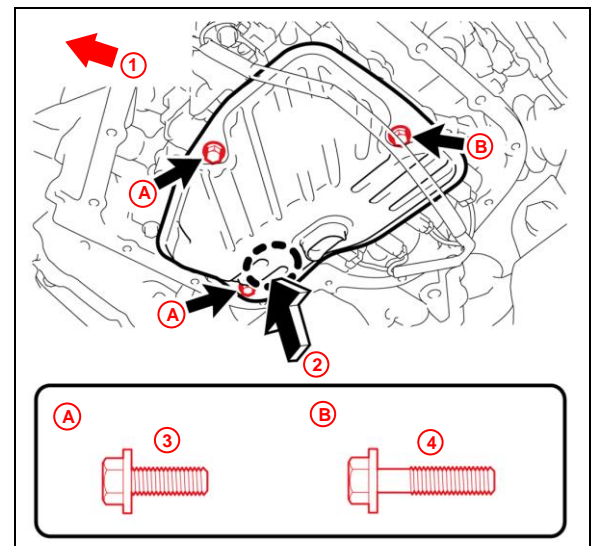

32. Tighten the three bolts.
Torque: 10.8N*m (110kgf*cm, 8ft*lbf)

1	Front of Vehicle
2	Pressure Application Area
3	16 mm Bolt
4	25 mm Bolt

CVT Hiss Noise Valve Body Replacement

Repair Procedure (continued)

Valve Body Installation (continued)

33. Reinstall the CVT oil pan sub-assembly.
Remove the three CVT oil cleaner magnets from the CVT oil pan sub-assembly.
34. Clean off ANY metal particles adhered to the three CVT oil cleaner magnets.
35. Clean the CVT oil pan sub-assembly and remove ANY metal particles, sludge, etc.

Figure 29. Location of Oil Pan Cleaner Magnets

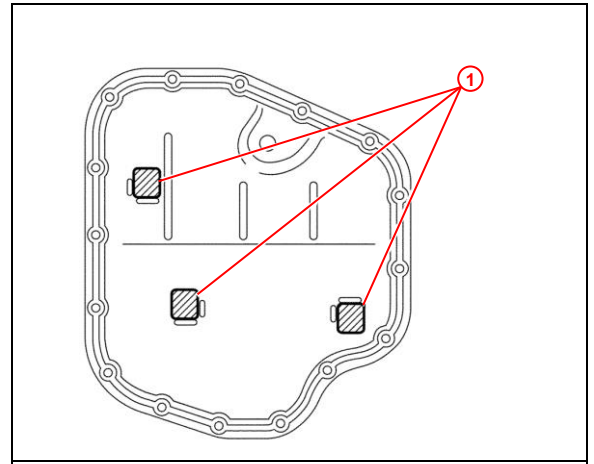

1	CVT Oil Cleaner Magnet
----------	-------------------------------

36. Install the NEW CVT oil pan gasket.

NOTICE

- Clean the mating surfaces of the CVT oil pan sub-assembly and the transmission case with wipes to remove grease, moisture, and/or dirt.
- Do NOT use brake cleaner.

Figure 30. CVT Gasket Installation

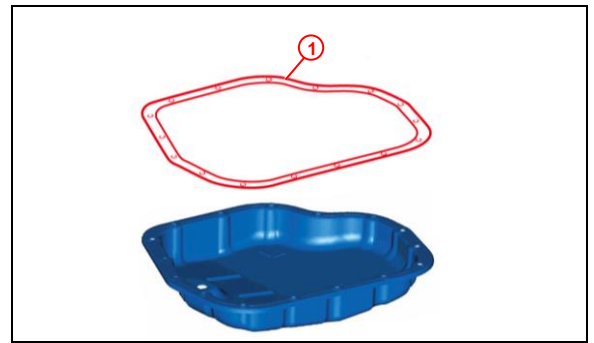

1	CVT Oil Pan Gasket
----------	---------------------------

CVT Hiss Noise Valve Body Replacement

Repair Procedure (continued)

Valve Body Installation (continued)

37. Temporarily and evenly tighten the 16 bolts to prevent distortion.
38. Temporarily reinstall the CVT oil pan sub-assembly to the transmission case.

NOTICE

Push the wiring to the center of the CVT to prevent the CVT wiring from being caught between the CVT case and CVT oil pan sub-assembly.

39. Tighten the 16 bolts.
Torque: 7.8N*m (80kgf*cm, 69in*lbf)

40. Refill the CVT fluid.
Refer to TIS, applicable model and model year Repair Manual:
 - 2016 iM:
Drivetrain – K313 CVT – [“K313 CVT: Continuously Variable Transaxle Fluid: Replacement”](#)

41. Check for fluid leaks.

42. Perform CVT system initialization.
Refer to TIS, applicable model and model year Repair Manual:
 - 2016 iM:
Drivetrain – K313 CVT – [“K313 CVT: Continuously Variable Transaxle Fluid: Initalization”](#)

43. Test-drive the vehicle to confirm the hissing noise is no longer present.

Figure 31. Oil Pan Sub-Assembly Installation

