



# Technical Service Bulletin

SUBJECT:		No:	<b>TSB-19-55-003</b>
<b>UPDATED DIAGNOSTIC TROUBLE CODE PROCEDURES FOR A/C CONTROL UNIT - SERVICE MANUAL REVISION</b>		DATE:	<b>March 2019</b>
		MODEL:	<b>2016 i-MiEV</b>
<b>CIRCULATE TO:</b>	<input type="checkbox"/> GENERAL MANAGER	<input checked="" type="checkbox"/> PARTS MANAGER	<input checked="" type="checkbox"/> TECHNICIAN
<input checked="" type="checkbox"/> SERVICE ADVISOR	<input checked="" type="checkbox"/> SERVICE MANAGER	<input type="checkbox"/> WARRANTY PROCESSOR	<input type="checkbox"/> SALES MANAGER

## PURPOSE

This TSB updates the Heater, Air Conditioning and Ventilation section of the affected Service Manual to update Diagnostic Trouble Code procedures for DTC B1106 and B1108, of the A/C Control Unit. These procedures have been updated due to the addition of the **Main Drive Lithium-ion Battery Disassembly & Maintenance** procedure to 54D-Electric Motor Unit and Main Drive Lithium-ion Battery.

## AFFECTED VEHICLES

- 2016 i-MiEV

## AFFECTED SERVICE MANUALS

- 2016 i-MiEV Service Manual, Group 55-Heater, Air Conditioning and Ventilation



Please **replace** the existing information for DTC B1106 in the 2016 i-MiEV Service Manual, 55-Heater, Air Conditioning and Ventilation -> A/C Diagnosis -> Diagnostic Trouble Code Procedures <A/C Control Unit> -> Code No. B1106, with the following updated information.

---

**Code No. B1106 ELC. compressor input VOLT.(low)**

---

**DTC SET CONDITION**

DTC B1106 is stored when the low voltage abnormality (high voltage less than DC 195 V is detected for 3 seconds) judged by the A/C compressor inverter is detected.

**TROUBLESHOOTING HINT**

- Malfunction of high-voltage connector and wiring harness
- Malfunction of high-voltage fuse No. 2
- Poor connection of high-voltage fuse No. 2
- Malfunction of A/C compressor
- Bus bar in the Main Drive Lithium-ion Battery poorly tightened

**DIAGNOSIS**

---

**STEP 1. Using scan tool MB991958, diagnose the CAN bus line**** CAUTION**

**To prevent damage to scan tool MB991958, always turn the electric motor switch to the "LOCK" (OFF) position before connecting or disconnecting scan tool MB991958.**

- (1) Connect scan tool MB991958. Refer to "How to connect the Scan Tool (M.U.T.-III)."
- (2) Turn the electric motor switch from "LOCK" (OFF) position to "ON" position.
- (3) Diagnose the CAN bus line.
- (4) Turn the electric motor switch from "ON" position to "LOCK" (OFF) position.

**Q: Is the CAN bus line found to be normal?**

**YES :** Go to Step 2.

**NO :** Repair the CAN bus line. (Refer to GROUP 54C, Diagnosis).

---

**STEP 2. Recheck for DTC.**

Recheck if the DTC is stored.

- (1) Erase the DTC.
- (2) Turn the electric motor switch from "LOCK" (OFF) position to "ON" position.
- (3) Check if the DTC is stored.

**Q: Is the DTC stored?**

**YES :** Go to Step 3.

**NO :** It can be assumed that this malfunction is intermittent. Refer to GROUP 00, How to Use Troubleshooting/ Inspection Service Points – How to Cope with Intermittent Malfunctions.

---

**STEP 3. Check the high-voltage connector and wiring harness.**

**⚠ DANGER**

- **Carry out the check on the high-voltage circuit while reading carefully the precautions on handling a high-voltage vehicle. (Refer to GROUP 54D - Precautions on how to use the high-voltage vehicle.)**
- **Wear the specified protection equipment during the check.**

1. Shut down the high voltage. (Refer to GROUP 00 – Precautions before Service - Precautions on handling high-voltage vehicle.)

2. G-20 Check the A/C compressor connector.

3. G-22 Check the high-voltage fuse No. 2 connecting bolt for looseness.

4. Visually check and check the continuity of the high-voltage fuse No. 2.

5. Visually check the following high-voltage wiring harnesses for damage.

- High-voltage wiring harness on Main Drive Lithium-ion Battery side
- High-voltage wiring harness on A/C compressor side

**Q: Is the check result normal?**

**YES** : Go to Step 4.

**NO <Malfunction of high-voltage fuse No. 2>** : Replace the high-voltage fuse No. 2.

**NO <Malfunction of connector and wiring harness on A/C compressor side>** : Replace the A/C compressor.

**NO <Malfunction of wiring harness on Main Drive Lithium-ion Battery side>** : Go to Step 6.

---

**STEP 4. Recheck for DTC.**

Check again if the DTC is stored.

- (1) Connect scan tool MB991958 to the data link connector
- (2) Turn the electric motor switch from "LOCK" (OFF) position to "ON" position.
- (3) Check if the DTC is stored.
- (4) Turn the electric motor switch from "ON" position to "LOCK" (OFF) position.

**Q: Is the DTC stored?**

**YES** : Go to Step 5.

**NO** : The procedure is complete.

---

**STEP 5. After replacing the A/C compressor, check again if the DTC is stored.**

**Q: Is the DTC stored?**

**YES** : Go to Step 6.

**NO** : This diagnosis is complete.

---

**STEP 6. Check the bus bar in the Main Drive Lithium-ion Battery.**

- (1) Check the bus bar in the Main Drive Lithium-ion Battery.

**Q: Is the check result normal?**

**YES** : This diagnosis is complete.

**NO** : Retighten the bus bar in the Main Drive Lithium-ion Battery.

Please **replace** the existing information for DTC B1108 in the 2016 i-MiEV Service Manual, 55-Heater, Air Conditioning and Ventilation -> A/C Diagnosis -> Diagnostic Trouble Code Procedures <A/C Control Unit> -> Code No. B1108, with the following updated information.

---

### Code No. B1108 Electric water heater fail 1

---

#### DTC SET CONDITION

DTC B1108 is stored when the outlet temperature of the heater does not raise to a temperature higher than the inlet temperature by 3°C (37°F) or more for 30 seconds or more.

#### TROUBLESHOOTING HINT

- Insufficient volume of water heater fluid

- Malfunction of high-voltage fuse No. 3
- Poor connection of high-voltage fuse No. 3
- Malfunction of heater water pump assembly
- Malfunction of EV water PTC heater
- Damaged harness wires and connectors
- Malfunction of A/C control unit
- Bus bar in the Main drive Lithium-ion Battery poorly tightened

### DIAGNOSIS

---

#### STEP 1. Using scan tool MB991958, diagnose the CAN bus line

##### CAUTION

To prevent damage to scan tool MB991958, always turn the electric motor switch to the "LOCK" (OFF) position before connecting or disconnecting scan tool MB991958.

- (1) Connect scan tool MB991958. Refer to "How to connect the Scan Tool (M.U.T.-III)."
- (2) Turn the electric motor switch from "LOCK" (OFF) position to "ON" position.
- (3) Diagnose the CAN bus line.
- (4) Turn the electric motor switch from "ON" position to "LOCK" (OFF) position.

#### Q: Is the CAN bus line found to be normal?

**YES** : Go to Step 2.

**NO** : Repair the CAN bus line. (Refer to GROUP 54C, Diagnosis).

---

#### STEP 2. Recheck for DTC.

Recheck if the DTC is stored.

- (1) Erase the DTC.
- (2) Turn the electric motor switch from "LOCK" (OFF) position to "ON" position.
- (3) Check if the DTC is stored.

#### Q: Is the DTC stored?

**YES** : Go to Step 3.

**NO** : It can be assumed that this malfunction is intermittent. Refer to GROUP 00, How to Use Troubleshooting/ Inspection Service Points – How to Cope with Intermittent Malfunctions.

---

**STEP 3. Check the water heater fluid volume.**

**⚠ CAUTION**

Do not operate the water pump with the water heater fluid level in the heater condenser tank lowered to the "L" line or below. If it is operated, the bearing of the water pump is damaged, and the water pump may be broken or the service life may be shortened.

- (1) Check that the water heater fluid level in the heater condenser tank stays a range between the "F" line and "L" line.
- (2) Check that the water heater fluid is not contaminated with an oil or others.

**Q: Is the water heater fluid volume correct?**

**YES** : Go to Step 4.

**NO** : Make the water heater fluid volume correct.

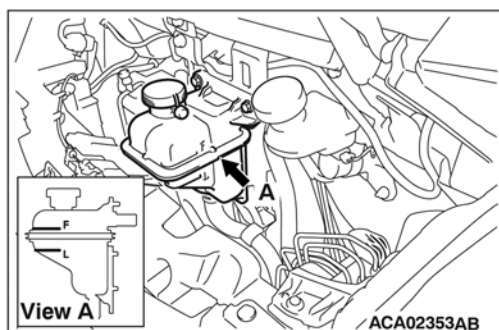

---

**STEP 4. Check the water heater fluid flow.**

Drive the heater in READY status and visually check the flow of the water fluid volume in the heater condenser tank.

**Q: Is the water heater fluid confirmed?**

**YES** : Go to Step 10.

**NO <No heater water pump assembly running noise can be heard>** : Go to Step 5.

**NO <A heater water pump assembly running noise can be heard, but the water heater fluid cannot be confirmed>** : Replace the heater water pump assembly.

---

**STEP 5. Check heater water pump connector A-109 for loose, corroded or damaged terminals, or terminals pushed back in the connector**

**Q: Are heater water pump connector A-109 in good condition?**

**YES** : Go to Step 6.

**NO** : Repair or replace the connector. Refer to GROUP 00E, Harness Connector Inspection.

---

**STEP 6. Measure the resistance at A-109 heater water pump assembly connector.**

- (1) Disconnect the heater water pump assembly connector A-109, and measure at the wiring harness side.
- (2) Resistance between terminal No. 1 and ground

**OK: The measured value should be 2 ohms or less**

**Q: Is the check result normal?**

**YES :** Go to Step 9.

**NO :** Go to Step 7.

---

**STEP 7. Check grounding connector B-122 for loose, corroded or damaged terminals, or terminals pushed back in the connector.**

**Q: Are heater grounding connector B-122 in good condition?**

**YES :** Go to Step 8.

**NO :** Repair or replace the connector. Refer to GROUP 00E, Harness Connector Inspection.

---

**STEP 8. Check the wiring harness between A-109 heater water pump assembly connector (terminal 1) and the grounding connector B-122 (terminal 5).**

- Check the ground wires for open circuit.

**Q: Is t the wiring harness between A-109 heater water pump assembly connector (terminal 1) and the grounding connector B-122 (terminal 5) in good condition?**

**YES :** Intermittent malfunction. Refer to GROUP 00 – How to Use Troubleshooting/Inspection Service Points, – How to Cope with Intermittent Malfunctions.

**NO :** Repair or replace the wiring harness. Refer to GROUP 00E, Harness Connector Inspection.

---

**STEP 9. Check the heater water pump assembly.**

** CAUTION**

**Do not operate the heater water pump with no water heater fluid in the heater water pump assembly. If the heater water pump assembly spins, a failure may occur.**

Connect the battery terminal (+) side to the heater water pump assembly connector terminal No. 2, 3, and check that the motor operates when connecting the battery terminal (-) side to the terminal No. 1.

**Q: Is the check result normal?**

**YES :** Go to Step 10.

**NO :** Replace the heater water pump assembly.

---

**STEP 10 .Using scan tool MB991958 actuator test and data list <A/C CONTROL UNIT>**

Check the data list for the ETACS (Refer to GROUP 54A – ETACS, Service Data Reference Table.).  
Check the results of the actuator test with the service data.

**Actuator test**

- Item 1: ELC.water heater test mode

**Data list**

- Item 7: ELC.water heater test status

*NOTE: Because actuator test "item1: ELC. water heater test mode" checks variations in the current, turn OFF other electric equipment before the test.*

**Q: Is the check result normal?**

**YES** : Go to Step 11.

**NO** : Go to Step 16.

---

**STEP 11 .Using scan tool MB991958 data list <A/C CONTROL UNIT>**

Check the data list for the ETACS (Refer to GROUP 54A – ETACS, Service Data Reference Table.).  
Check the results of the actuator test with the service data.

- Item 10: ELC.water heater inlet sensor
- Item 11: ELC.water heater outlet sensor

**Q: Is the check result normal?**

**YES** : Go to Step 20.

**NO** : Go to Step 12.

---

**STEP 12. Check EV water PTC heater connector A-113 for loose, corroded or damaged terminals, or terminals pushed back in the connector**

**Q: Are heater connector A-113 in good condition?**

**YES** : Go to Step 13.

**NO** : Repair the damaged connector.

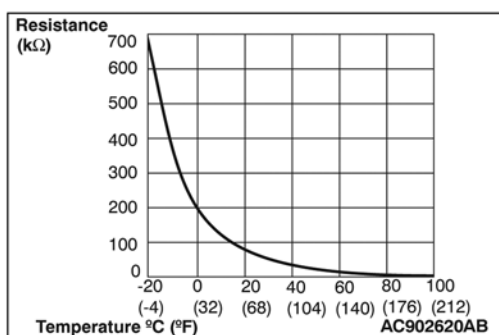
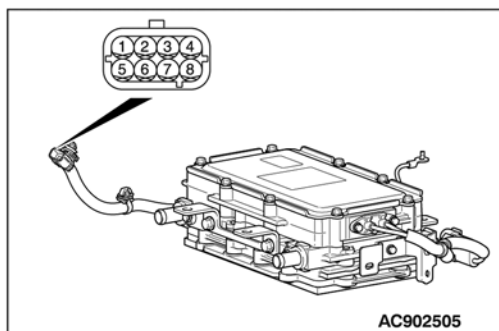

---

**STEP 13. Check the heater outlet water temperature sensor/heater inlet water temperature sensor.**

When the resistance value between the heater terminals 6 and 7 <heater outlet water temperature sensor> or 6 and 8 <heater inlet water temperature sensor> is measured under the temperature conditions at 2 points or more, the resistance value shall almost satisfy the value indicated in the figure.

**Q: Is the check result normal?**

**YES :** Go to Step 14.

**NO :** Replace the heater.

---

**STEP 14. Check heater control unit connector C-101 for loose, corroded or damaged terminals, or terminals pushed back in the connector**

**Q: Are heater control unit connector C-101 in good condition?**

**YES :** Go to Step 15.

**NO :** Repair the damaged connector.

---

**STEP 15. Check the wiring harness between A-113 EV water PTC heater connector (terminals 6, 7 and 8) and C-101 A/C control unit connector (terminals 19, 17 and 18).**

- Check the input line for open circuit.

*NOTE: Also check the intermediate connector B-01 for loose, corroded, or damaged terminals, or terminals pushed back in the connector. If intermediate connector B-01 is damaged, repair or replace the connector as described in GROUP 00E, Harness Connector Inspection.*

**Q: Is the wiring harness between A-113 EV water PTC heater connector (terminals 6, 7 and 8) and C-101 A/C control unit connector (terminals 19, 17 and 18) in good condition?**

**YES :** Go to Step 20.

**NO :** Repair or replace the wiring harness. Refer to GROUP 00E, Harness Connector Inspection.



---

**STEP 16. Check A-113 EV water PTC heater connector A-113 for loose, corroded or damaged terminals, or terminals pushed back in the connector**

**Q: Are A-113 EV water PTC heater connector in good condition?**

**YES :** Go to Step 17.

**NO :** Repair the damaged connector.

---

**STEP 17. Check heater control unit connector C-113 for loose, corroded or damaged terminals, or terminals pushed back in the connector.**

**Q: Are heater control unit connector C-113 in good condition?**

**YES :** Go to Step 18.

**NO :** Repair or replace the connector. Refer to GROUP 00E, Harness Connector Inspection.

---

**STEP 18. Check the wiring harness between A-113 EV water PTC heater connector (terminals 1, 2, 3, 4 and 5) and C-113 A/C control unit connector (terminals 25, 33, 34, 35 and 36).**

- Check the input line for open circuit.

*NOTE: Also check the intermediate connector B-01 for loose, corroded, or damaged terminals, or terminals pushed back in the connector. If intermediate connector B-01 is damaged, repair or replace the connector as described in GROUP 00E, Harness Connector Inspection.*

**Q: Is the wiring harness between A-113 EV water PTC heater connector (terminals 1, 2, 3, 4 and 5) and C-113 A/C control unit connector (terminals 25, 33, 34, 35 and 36) in good condition?**

**YES :** Go to Step 19.

**NO :** Repair or replace the wiring harness. Refer to GROUP 00E, Harness Connector Inspection.

---

**STEP 19. Check the high-voltage connector and wiring harness.**

**⚠ DANGER**

- **Carry out the check on the high-voltage circuit while reading carefully the precautions on handling a high-voltage vehicle. (Refer to GROUP 54D - Precautions on how to use the high-voltage vehicle.)**
- **Wear the specified protection equipment during the check.**

1. Shut down the high voltage. (Refer to GROUP 00 – Precautions before Service - Precautions on handling high-voltage vehicle.)
2. G-21 Check the heater connector.
3. G-23 Check the high-voltage fuse No. 3 connecting bolt for looseness.
4. Visually check and check the continuity of the high-voltage fuse No. 3.
5. Visually check the following high-voltage wiring harnesses for damage.
  - High-voltage wiring harness on Main Drive Lithium-ion Battery side
  - High-voltage harness heater side

**Q: Is the check result normal?**

**YES :** Go to Step 21.

**NO <Malfunction of high-voltage fuse No. 3> :** Replace the high-voltage fuse No. 3.

**NO <Malfunction of wiring harness on heater side> :** Replace the heater.

**NO <Malfunction of wiring harness on Main Drive Lithium-ion Battery side> :** Go to Step 20.

---

**STEP 20. Check the bus bar in the Main Drive Lithium-ion Battery.**

- (1) Check the bus bar in the Main Drive Lithium-ion Battery.

**Q: Is the check result normal?**

**YES :** Go to Step 21.

**NO :** Retighten the bus bar in the Main Drive Lithium-ion Battery.

---

**STEP 21. Recheck for DTC.**

Check again if the DTC is stored.

- (1) Connect scan tool MB991958 to the data link connector
- (2) Turn the electric motor switch from "LOCK" (OFF) position to "ON" position.
- (3) Check if the DTC is stored.
- (4) Turn the electric motor switch from "ON" position to "LOCK" (OFF) position.

**Q: Is the DTC stored?**

**YES :** Go to Step 22.

**NO :** The procedure is complete.

---

**STEP 22. After replacing the A/C control unit, check again if the DTC is stored.**

**Q: Is the DTC stored?**

**YES :** Replace the heater.

**NO :** This diagnosis is complete.