



# Technical Service Bulletin

SUBJECT:		No: <b>TSB-19-54-006</b>	
<b>UPDATED BSW-ECU INSPECTION PROCEDURE - SERVICE MANUAL REVISION</b>		DATE: <b>March 2019</b>	
		MODEL: <b>2017 Outlander</b>	
<b>CIRCULATE TO:</b>	<input type="checkbox"/> GENERAL MANAGER	<input checked="" type="checkbox"/> PARTS MANAGER	<input checked="" type="checkbox"/> TECHNICIAN
<input checked="" type="checkbox"/> SERVICE ADVISOR	<input checked="" type="checkbox"/> SERVICE MANAGER	<input type="checkbox"/> WARRANTY PROCESSOR	<input type="checkbox"/> SALES MANAGER

## PURPOSE

This TSB updates the Chassis Electrical section of the affected Service Manual to update the Blind Spot Warning (BSW) ECU Inspection procedure.

## AFFECTED VEHICLES

- 2017 Outlander

## AFFECTED SERVICE MANUALS

- 2017 Outlander Service Manual, Group 54-Chassis Electrical



Please **replace** the existing information for BSW-ECU Inspection (3 pages below, labeled "<Old>") with the updated information that follows (8 pages, labeled "<New>") in the 2017 Outlander Service Manual, Group 54-Chassis Electrical -> 54A -> Blind Spot Warning (BSW)/Rear Cross Traffic Alert (RCTA) -> BSW-ECU Inspection.

**CHASSIS ELECTRICAL**  
**BLIND SPOT WARNING (BSW)/REAR CROSS TRAFFIC ALERT (RCTA)**

**BSW-ECU INSPECTION**

M1549905200033

**⚠ CAUTION**

- Do not repair the rear bumper assembly around the BSW-ECU. If yes, the radar will reflect irregularly to cause the BSW/RCTA system to work incorrectly.

**⚠ CAUTION**

- To check the ECU accurately, keep away 4 meters (13.1 feet) or more from the vehicle (There should not be any metal objects around the vehicle).

Check the BSW-ECU according to the procedure below after any of the following operations is performed:

- The BSW-ECU is removed and installed
- The rear bumper assembly is repaired

**Inspection procedure**

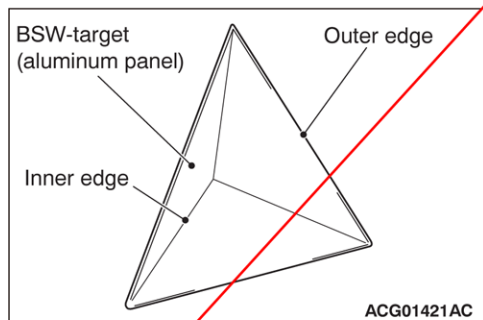
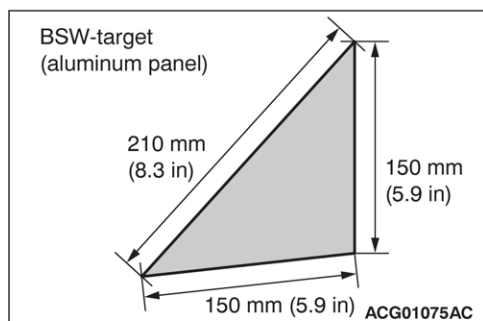

1. Prepare three approx. 0.5 mm (0.02 in)-thick flat aluminum panels, which measure 150 mm (5.9 in) × 150 mm (5.9 in) × approx. 210 mm (8.3 in) (panels can be thinner if not distorted). Make a triangular pyramid by using these panels.

**NOTE:**

- To build the pyramid, apply adhesive tape from outside. Otherwise, the radar will reflect irregularly.
- Be careful not to distort the aluminum panels.
- Be careful not to damage the inside of the BSW target (triangular pyramid) as the radar reflects inside it.

**CHASSIS ELECTRICAL**  
**BLIND SPOT WARNING (BSW)/REAR CROSS TRAFFIC ALERT (RCTA)**

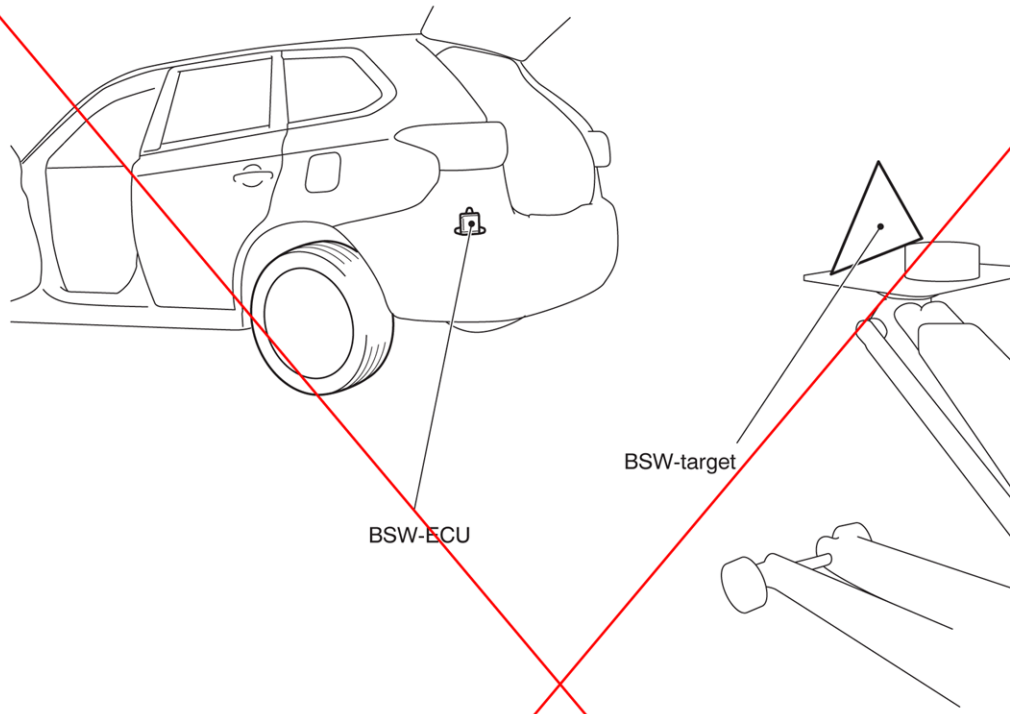

ACG01423AB

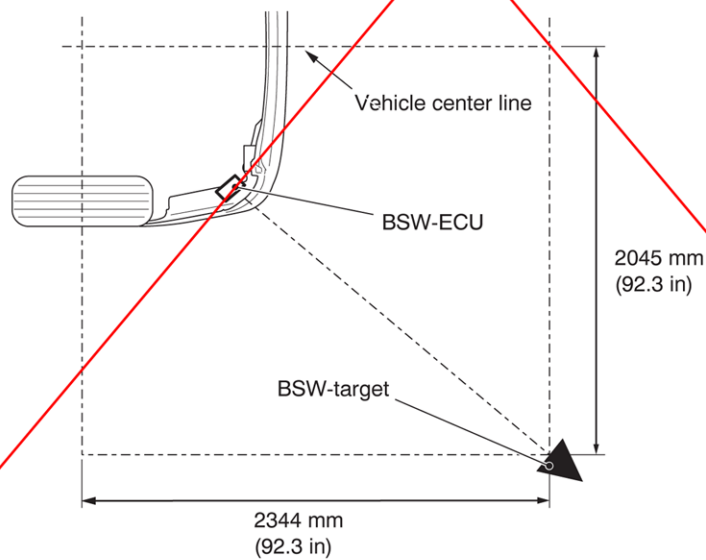

ACG01426AB

2. Place the BSW target (triangular pyramid) as shown [2045 mm (80.5 in) away laterally from the center of vehicle, 2344 mm (92.3 in) behind from the center of the rear axle].

**CHASSIS ELECTRICAL**  
**BLIND SPOT WARNING (BSW)/REAR CROSS TRAFFIC ALERT (RCTA)**

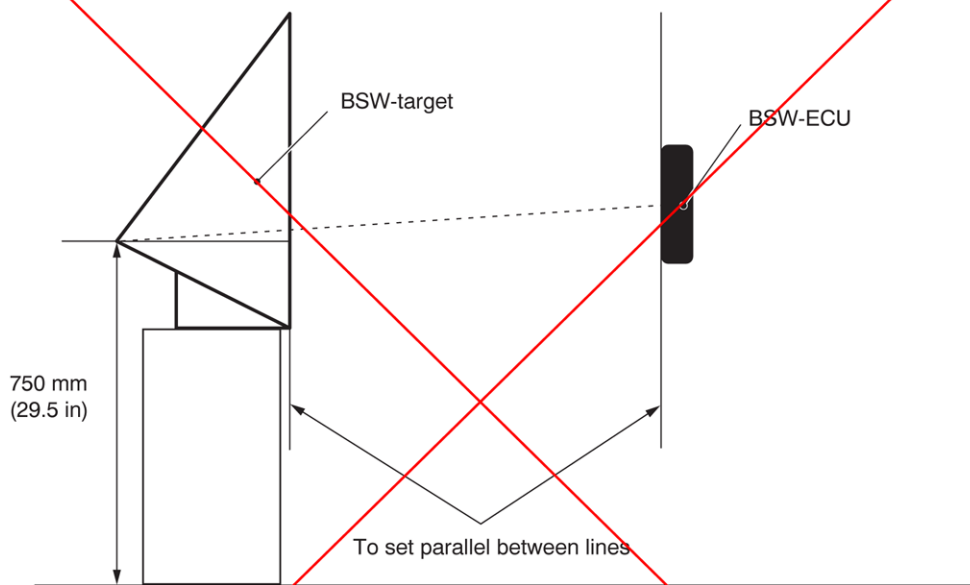

ACG01419AB

3. Place the front face of the BSW target (triangular pyramid) as shown. It should be 750 mm (29.5 in) perpendicularly away from the floor. Its front face should be parallel to the front face of the BSW-ECU.  
*NOTE: The vehicle should be parked on flat surface with its tire inflation pressure within the specification. Empty the luggage compartment and the vehicle should be at an unladen weight.*
4. Connect the scan tool (M.U.T.-III).
5. Select the scan tool (M.U.T.-III) screen menu as follows.
  - (1) Select "BSW."
  - (2) Select "Special function."
  - (3) Select "Test."
  - (4) Select "Radar detecting angle check."
6. No action should be taken when the radar recognition angle is within  $\pm 3$  deg.
7. When it is not within  $\pm 3$  deg, install the BWS-ECU again. Then repeat the check process.

<Old>

**NOTE: U.S. Dealers should use Essential Tool MB99RT01V, "BSW/RCTA Tester" for checking the BSW radar calibration. If this tool is not available, follow the instructions below for "Fabricating a reflector for inspection of the BSW" to create a tool for the BSW-ECU inspection.**

**CHASSIS ELECTRICAL**  
**BLIND SPOT WARNING (BSW)/REAR CROSS TRAFFIC ALERT (RCTA)**

**BSW-ECU INSPECTION**

M1549905200088

**⚠ CAUTION**

**Do not modify or repair the area of the rear bumper surrounding the BSW-ECU. The radar may irradiate incorrectly.**

When any of the followings is carried out, observe the procedure below to check the BSW-ECU.

- BSW-ECU removal and installation
- Modifying the rear bumper assembly

**Fabricating a reflector for inspection of the BSW**

1. Obtain an aluminum plate and the tools below:

**What to obtain**

- a. Aluminum plate: 300 mm (11.8 inches) (W), 150 mm (5.9 inches) (H) and 0.5 mm (0.02 inch) (D) or more

*NOTE: To fabricate the plate easily, we recommend that the plate should be 0.5 mm (0.02 inch) thick. If thinner, the plate may be curved easily. If thicker, it will take longer to fabricate the plate.*

- b. Protective gloves
- c. 300-mm (11.8 inches) long scale
- d. Knife
- e. Adhesive tape

2. Wear protective gloves and scribe the lines on the aluminum plate as shown.

**NOTE:**

- Check the scribed lines for accuracy (parallelism and perpendicularity) in several points.
- Place cloths under the plate to protect it from scratches.
- When the plate is covered with a protective film at the factory, do not peel off it.

3. Cut the plate according to the steps below:

- (1) Align a scale along the scribed line.
- (2) Hold the scale securely. Use it as a guide to make a V-groove on the plate with a knife.
- (3) Repeat the process above approximately 20 times to deepen the V-groove.

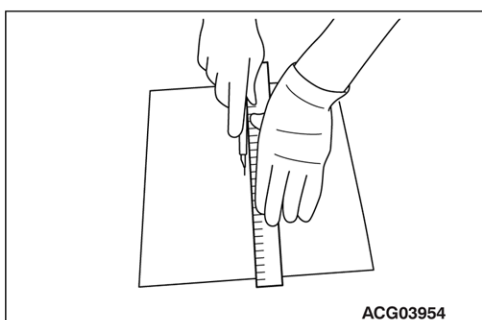
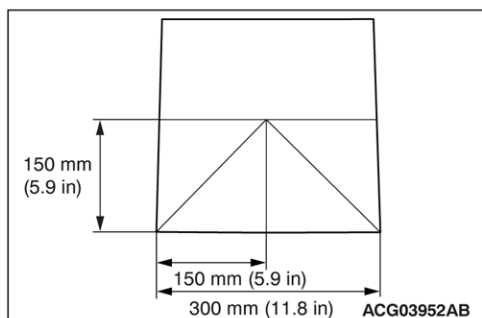
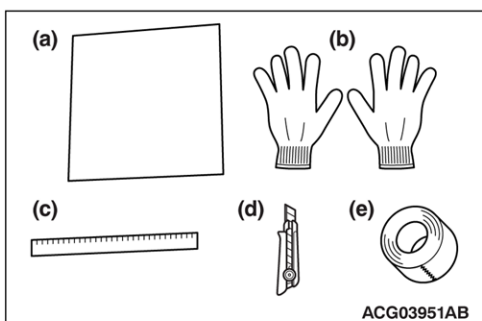

**CHASSIS ELECTRICAL**  
**BLIND SPOT WARNING (BSW)/REAR CROSS TRAFFIC ALERT (RCTA)**

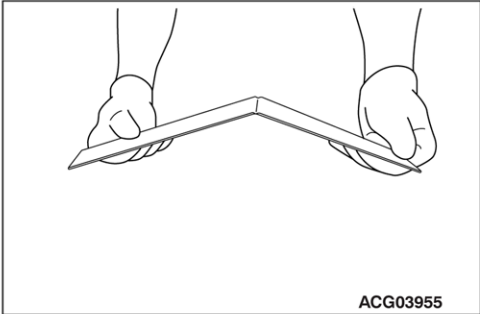

- (4) Bend the plate slightly to check that the plate can be bent sharply along the V-groove as shown. If no, the V-groove is too shallow. Repeat step (3).
- (5) Bend the plate several times to cut it.

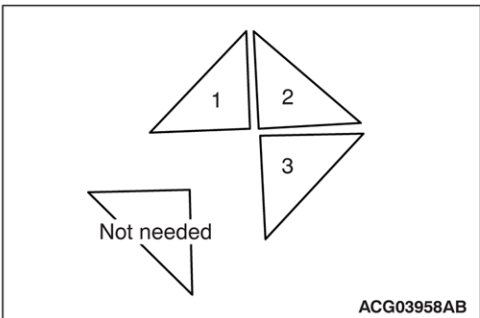

- 4. Assemble the plate pieces according to the steps below to make a triangular pyramid.
  - (1) Use three of four plate pieces. If the piece is covered with a protective film, do not peel off it yet.

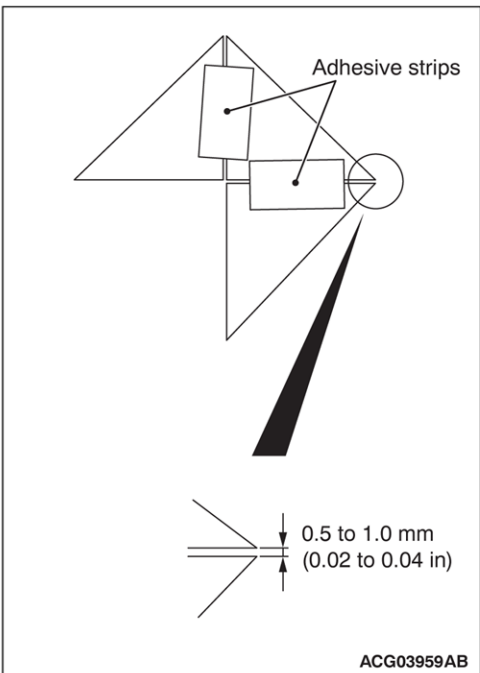

- (2) Place the plate pieces and apply adhesive strips together as shown. When the plate pieces are covered with a protective film, apply the strips on the non-covered surface. (Peel off only one side of films when both sides of the plate pieces are protected)
- NOTE: To make a triangular pyramid, clearance between the plates should be 0.5 to 1.0 mm (0.02 to 0.04 inch).*

**CHASSIS ELECTRICAL**  
**BLIND SPOT WARNING (BSW)/REAR CROSS TRAFFIC ALERT (RCTA)**

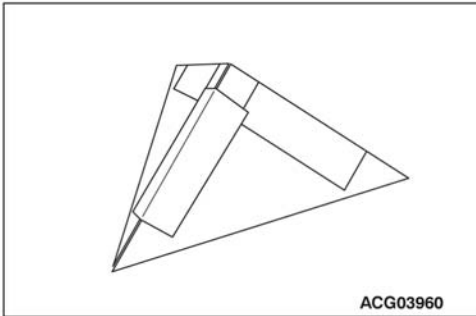

(3) Apply an adhesive strip on the edges to assemble the triangular pyramid as shown.

**NOTE:**

- Apply adhesive strips on the outside of the panel as the inside reflects the radar wave.
- When protective films are applied on the inside, peel off them.

**Complete**

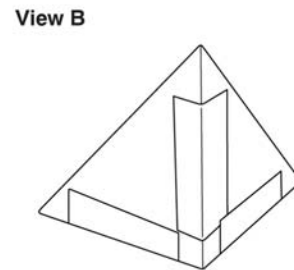
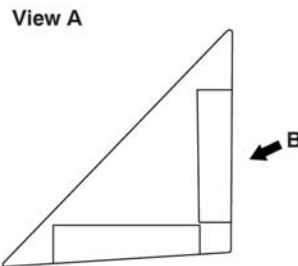
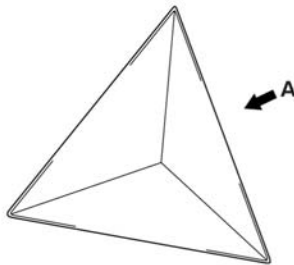

ACG04031AB

<New>

**CHASSIS ELECTRICAL**  
**BLIND SPOT WARNING (BSW)/REAR CROSS TRAFFIC ALERT (RCTA)**

**Locating the BSW reflector**

**CAUTION**

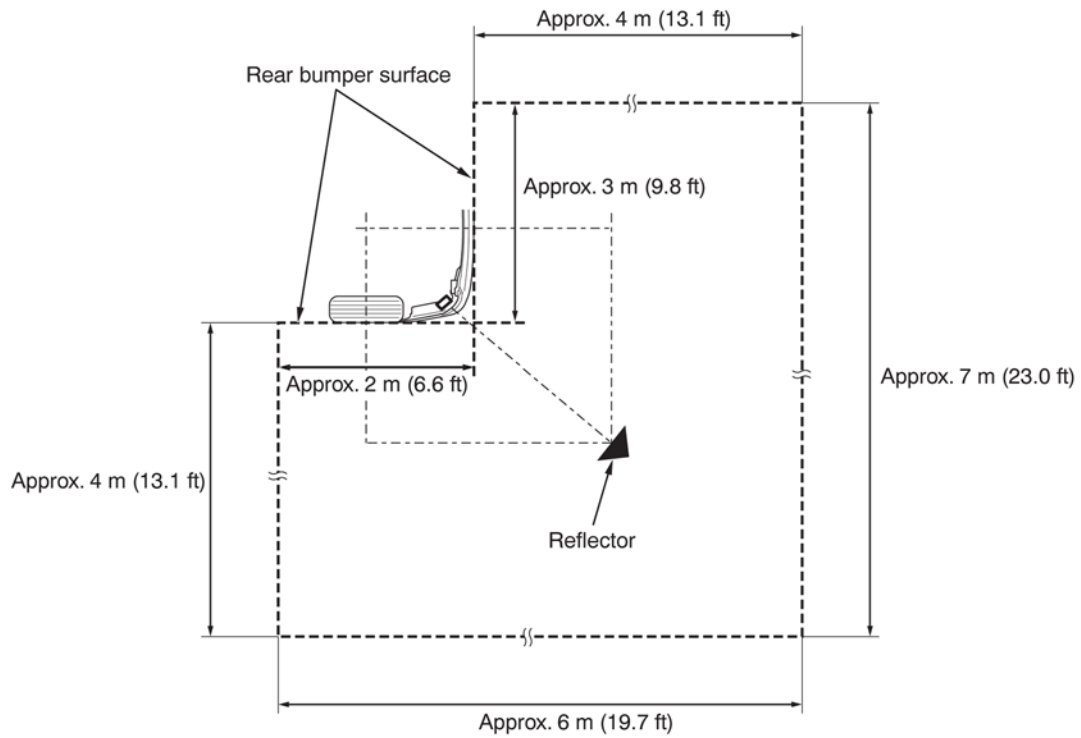

ACG04032AB

**To carry out an accurate inspection, keep away any metal obstacles other than a bench (e.g. garage jack) where the reflector is placed from the reflector as shown.**

<New>



**CHASSIS ELECTRICAL**  
**BLIND SPOT WARNING (BSW)/REAR CROSS TRAFFIC ALERT (RCTA)**

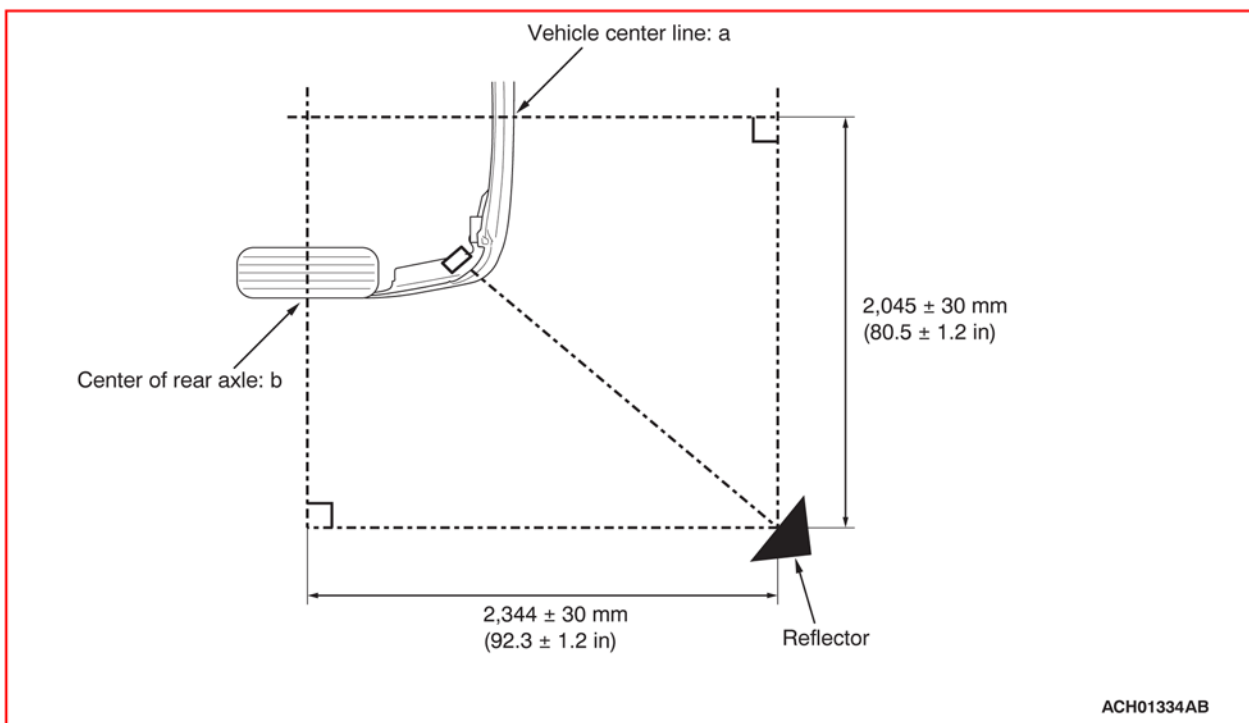

1. Draw line (a) from the center of the Three-diamond mark on the front and rear ends (line a: vehicle center line).
2. Draw line (b) from the center of the Three-diamond mark on the rear wheel (line b: rear axle center line).
3. The bottom of the reflector should be positioned  $2,045 \pm 30$  mm ( $80.5 \pm 1.2$  inches) from the vehicle center line and  $2,344 \pm 30$  mm ( $92.3 \pm 1.2$  inches) from the rear axle center line.

<New>

**CHASSIS ELECTRICAL**  
**BLIND SPOT WARNING (BSW)/REAR CROSS TRAFFIC ALERT (RCTA)**

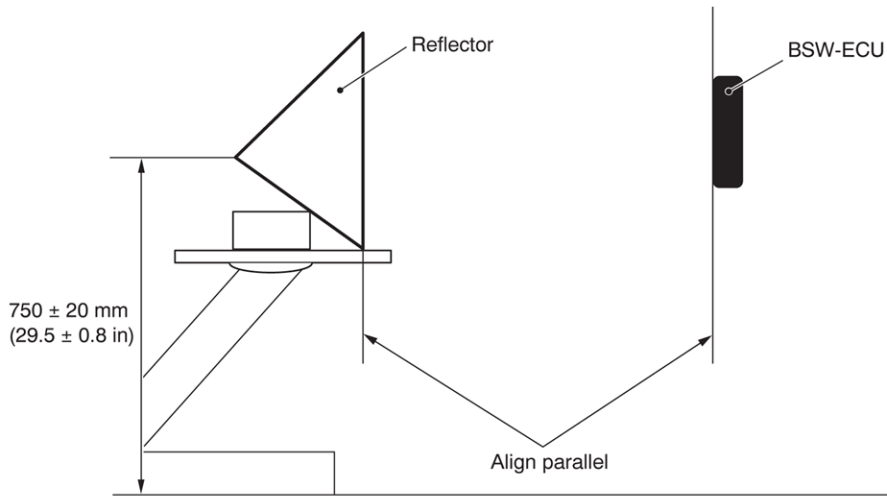

ACG03612AC

4. The top of reflector should be  $750 \pm 20$  mm ( $29.5 \pm 0.8$  inches) away from the floor and the bottom should be parallel to the BSW-ECU as shown.

*NOTE: Ensure that the tire pressures are correct and the vehicle is parked on a flat level at kerbside weight.*

### Check process

#### Required Special Tools:

- MB992744: Vehicle communication interface-Lite (V.C.I.-Lite)
- MB992745: V.C.I.-Lite main harness A
- MB992747: V.C.I.-Lite USB cable short
- MB992748: V.C.I.-Lite USB cable long
- MB991958: Scan Tool (M.U.T.-III Sub Assembly)
  - MB991824: Vehicles Communication Interface (V.C.I.)
  - MB991827: M.U.T.-III USB Cable
  - MB991910: M.U.T.-III Main Harness A (Vehicles with CAN communication system)

1. Connect the scan tool (M.U.T.-III).
2. Ensure that the BSW system is turned on. If no, operate the blind spot warning switch to turn on the system.
3. Proceed to the steps below on the scan tool (M.U.T.-III):
  - (1) Select "BSW" or "BSW(SUB)."

*NOTE: Select "BSW" for the BSW-ECU (master) and "BSW(SUB)" for the BSW-ECU (slave), respectively.*

- (2) Select "Special function."
  - (3) Select "Test."
  - (4) Select "Radar recognition angle inspection."
4. Observe the flow chart below:

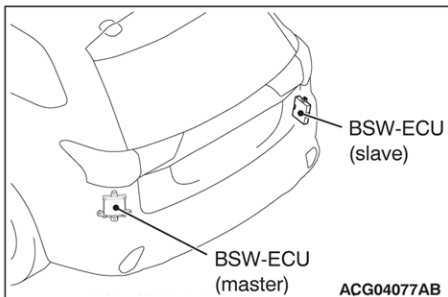

<New>

**CHASSIS ELECTRICAL**  
**BLIND SPOT WARNING (BSW)/REAR CROSS TRAFFIC ALERT (RCTA)**

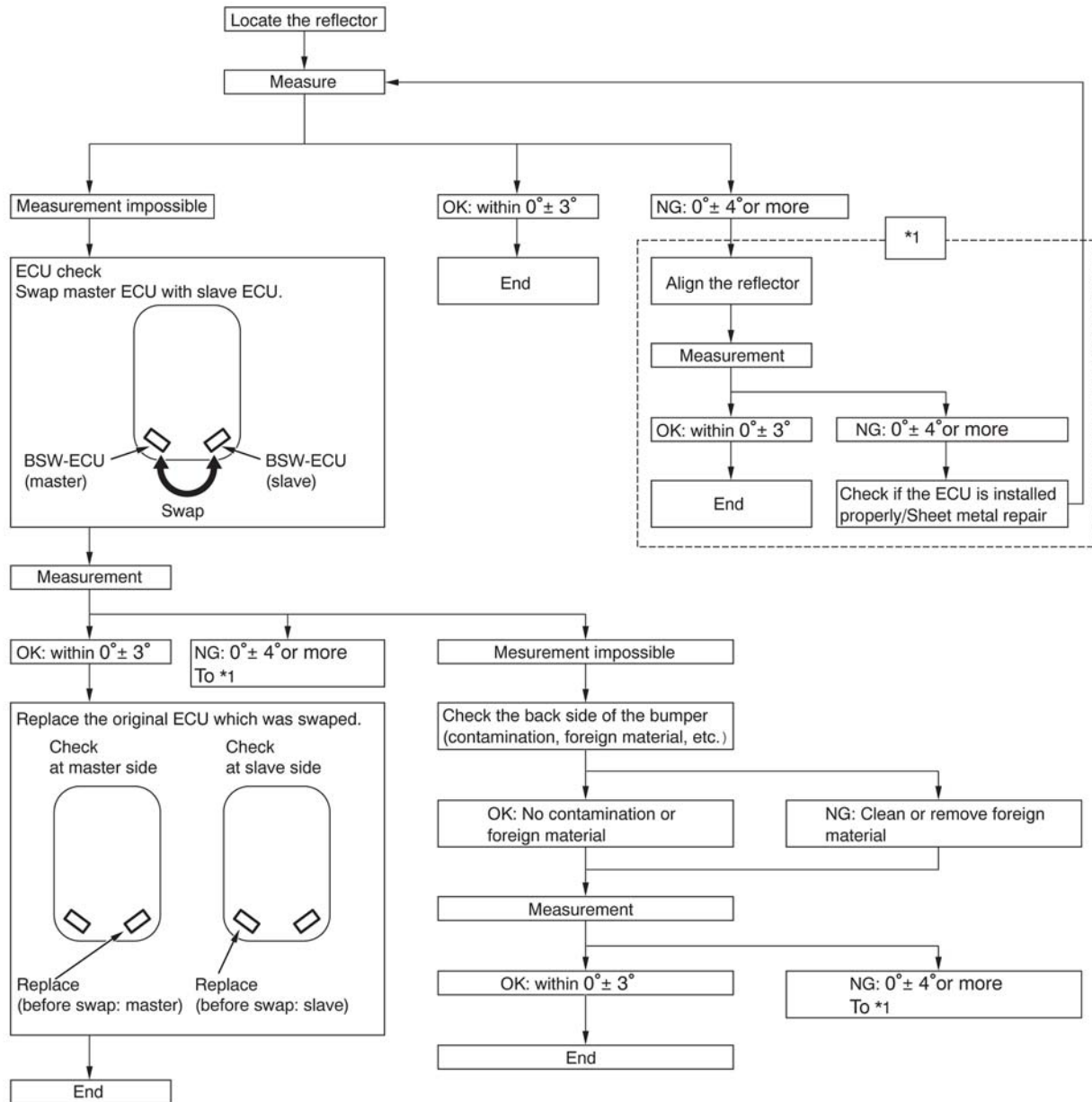

ACG04127AB

**NOTE:** If not within the specified value, any of the causes below is suspected.

- The BSW-ECU is defective.
- The BSW-ECU bracket is defective (deformed)
- The BSW-ECU bracket mount is defective (deformed)
- Damaged bumper (scratches or dents)

<New>

**CHASSIS ELECTRICAL**  
**BLIND SPOT WARNING (BSW)/REAR CROSS TRAFFIC ALERT (RCTA)**

**Radar recognition angle**

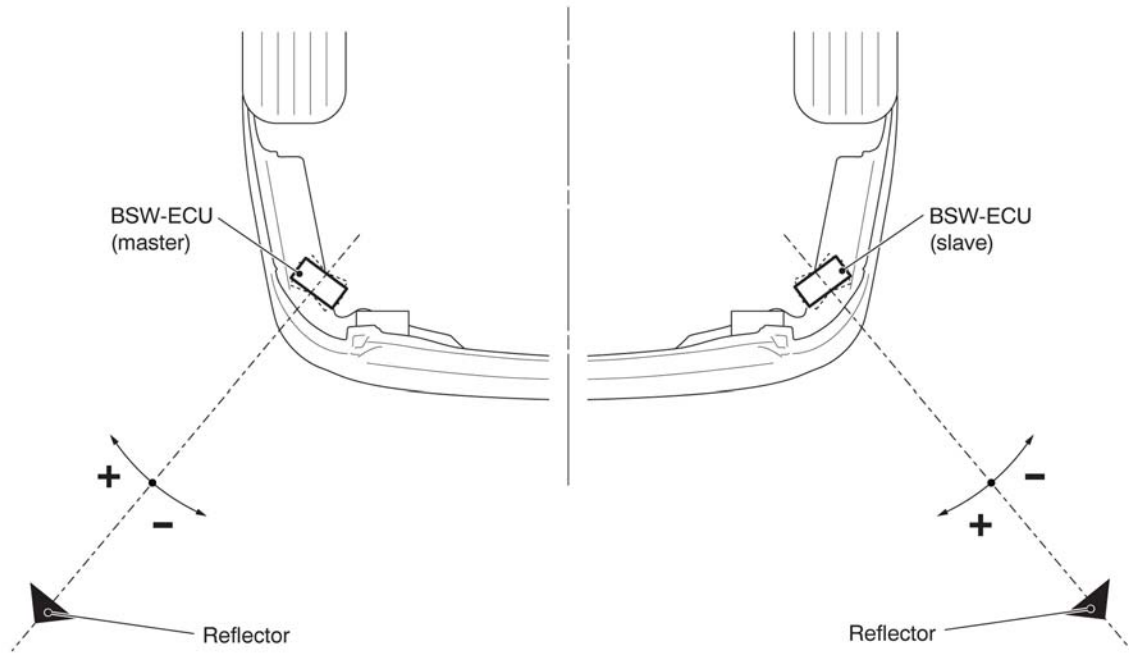

ACG04083AB

The illustration shows a radar recognition angle.

*NOTE: When the reflector is positioned straight against the BSW-ECU, "0°" should be shown. If the BSW-ECU is swayed clockwise, a positive value will be shown. If counterclockwise, a negative value will be shown.*

<New>