



## Technical Tip

<b>Topic</b>	32-19-01TT - Torque Converter Installation Check
<b>Market area</b>	United States 444 Volkswagen of America, Inc. (6444)
<b>Brand</b>	Volkswagen
<b>Date</b>	2/1/2019

## Condition

<b>ATTENTION:</b>
<b>THIS IS A TECH TIP, NOT A TECHNICAL BULLETIN.</b>
<b>TECH TIPS ARE NOT ASSOCIATED WITH WARRANTY CLAIMING.</b>

### Torque Converter Installation Check

Model(s)	Year	Eng. Code	Trans. Code	VIN Range From	VIN Range To
Jetta	2019	All	All	All	All

## Technical Background

A technical aid in determining correct torque converter installation.

When reinstalling the torque converter, 3 clicks should be felt to ensure correct seating and pump engagement. See figure one for the installation measurement.

## Service

The measurement in figure 1 is from the bell housing mating surface to the stud flanges on the torque converter studs. This must be at least 19.5mm.

Once the transmission is installed back onto the engine, the window on the case closest to the starter hole is a good visual reference point for rechecking.

When the torque converter is seated properly and not bolted to flywheel there will be approximately an 8mm (or less) gap, between the flywheel ring gear and the main transmission case. If the torque converter is not seated properly, the gap is increased to approximately 13mm in the same window location.

As a quick check, if a finger can fit between the starter gear and main transmission case (figure 2) it is most likely out too far. If you cannot fit a finger between the starter gear and main transmission case it is seated properly.

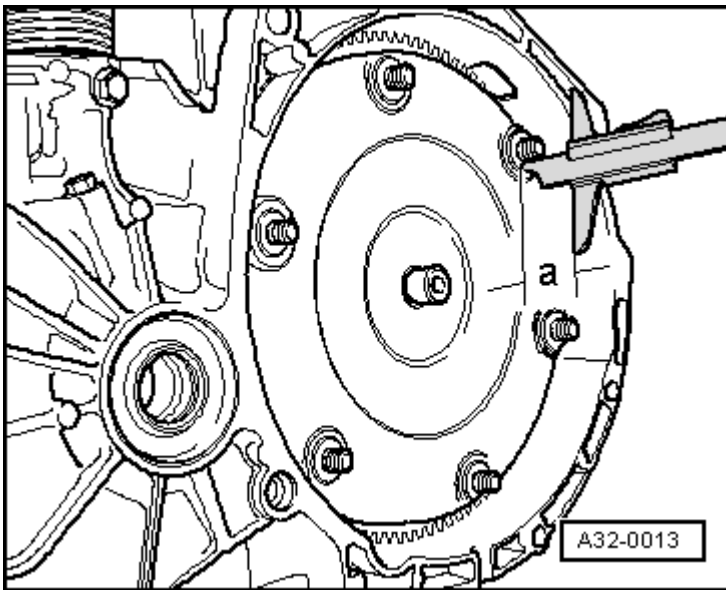

Figure 1: at least 19.5mm



Figure 2: Not seated properly, gap to great



## Additional Information

<b>Revision History</b>		
<b>Revision Number</b>	<b>Released Date</b>	<b>Reason For Update</b>
2053850/1	2/1/18	Original publication.

© 2019 Volkswagen Group of America, Inc. All rights reserved. Information contained in this document is based on the latest information available at the time of printing and is subject to the copyright and other intellectual property rights of Volkswagen Group of America, Inc., its affiliated companies and its licensors. All rights are reserved to make changes at any time without notice. No part of this document may be reproduced, stored in a retrieval system, or transmitted in any form or by any means, electronic, mechanical, photocopying, recording, or otherwise, nor may these materials be modified or reposted to other sites, without the prior expressed written permission of the publisher.