



Technical Service Bulletin

92 Washer solvent level warning on

92 19 17 2038151/9 February 7, 2019. Supersedes Technical Service Bulletin Group 92 number 19-16 dated January 23, 2019 for reasons listed below.

Model(s)	Year	VIN Range	Vehicle-Specific Equipment
All	2012 - 2020	All	Not Applicable

Condition

REVISION HISTORY		
Revision	Date	Purpose
9	-	Revised <i>Warranty</i> (Updated Labor Operations and added A7)
8	01/23/2019	Revised header (Added new models and model years) Revised <i>Warranty</i> (Corrected Q5 SRTs and added models)
7	08/06/2018	Revised header (Added model years) Revised <i>Warranty</i> (Corrected TT SRTs)

The washer solvent level warning is on in the driver information system (DIS), but the washer solvent level is correct. There is no functional restriction in the windshield washer system.

Technical Background

The sensitivity of the washer solvent level sensor (G33) can be affected by the type, concentration, and the presence of additives in the washer solvent currently in the tank. The operation of the level sensor relies on the composition of the solvent to provide an accurate message on the solvent level. Incorrect concentration and the presence of additives can contaminate the sensor and reduce its sensitivity.

Production Solution

Not applicable.



Technical Service Bulletin

Service

If the washer solvent reservoir is full and the low solvent warning is on, proceed as follows:

1. Empty the reservoir and for all vehicles *except* A3 Sedan and A3 Cabriolet, remove the level sensor. Clean the sensor probes using all-purpose cleaner **D 009 401 04** (Figure 1), then reinstall the level sensor.



Figure 1. D 009 401 04 all-purpose cleaner.



Technical Service Bulletin

2. For Audi A3 Sedan and A3 Cabriolet where the washer solvent level sensor is not removable the sensor probes can be cleaned by removing the reservoir, removing the filler neck from the reservoir and gaining access to the sensor probes (Figure 2).



Figure 2. Windshield washer level sensor probes as viewed through the tank opening.



Technical Service Bulletin

3. Saturate the tip of a cleaning brush with a rigid stem and long enough to reach the probes (approximately 10”) with all-purpose cleaner **D 009 401 04**. A humming bird feeder cleaning brush is shown in the illustration but any suitable cleaning brush with a tip constructed of the appropriate material will function well for this purpose (Figure 3).



*Figure 3. Applying all-purpose cleaner **D 009 401 04** to the tip of a humming bird feeder cleaning brush.*



Technical Service Bulletin

4. Thoroughly clean the sensor probes (Figure 4).



Figure 4. *Cleaning the sensor probes.*

5. Refill the reservoir with the correct type and concentration of solvent. Windshield cleaner concentrate with anti-freeze **G 052 164 M2** works best (Figure 5). This solvent can be adjusted for freeze protection to -70° C (-94° F), prevents washer jet contamination particularly on the “fan” type of washer jet, and is highly effective in removing residues and insects from the windshield.



Figure 5. *G 052 164 M2 windshield cleaner concentrate with anti-freeze.*

 **Note:**

Dealers in states such as California which have a restriction on windshield washer solvent VOC content can use Audi Windshield Washer Fluid – 35% pre-mix – (55 gallon) available from the Audi Top Service Supplies &



Technical Service Bulletin

Touch-Up Paint eStore as an alternative. This solvent contains no water repellants and has freeze protection to -22° F.

- The concentration and freeze point can be checked using the T10007A refractometer (Figure 6).

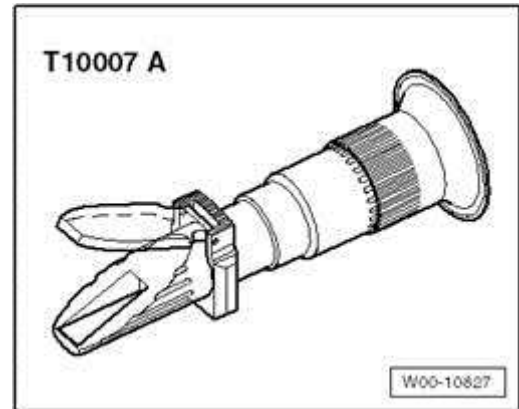

Figure 6. T10007A refractometer.

- Put a drop of washer fluid with the pipette on the glass of the refractometer. When viewing the refractometer, a light-dark border can be clearly recognized. Using the scale to the right (Figure 7), adjust the concentration of the solvent to accommodate the current weather conditions.

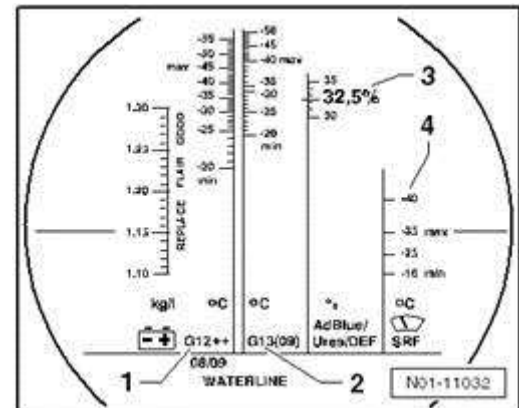

Figure 7. Scale in the view of the T10007A refractometer.

- Concentration guidelines:

Freeze protection	Windshield cleaner concentrate with anti-freeze G 052 164 M2	Water
-16 °C (3° F)	1 part	3 parts
-30 °C (-22° F)	1 part	2 parts
-40 °C (-40° F)	1 part	1.5 parts
-70 °C (-94° F)	1 part	0 parts



Technical Service Bulletin

Note:

It is not necessary to replace the windshield washer solvent level sensor when the cause of failure is contaminated sensor probes or incorrect washer solvent solution. Warranty claims for replacement of washer solvent level sensors that are found to not be faulty will not be reimbursed.

Warranty

Claim Type:	<ul style="list-style-type: none"> • 110 up to 48 Months/50,000 Miles. • G10 for CPO Covered Vehicles – Verify Owner. • If vehicle is outside any warranty, this Technical Service Bulletin is informational only. 		
Service Number:	9258		
Damage Code:	0040		
Labor Operations:	Q7 (up to and including MY 2015):		
	Lower Windshield washer reservoir remove + reinstall	9260 1900	See SRT
	Fluid level sensor remove + reinstall	9258 1950	See SRT
	Clean fluid level sensor and adjust solvent concentration	9258 9999	10 TU
	Q7 (From MY 2016 on):		
	Cover (plenum) remove + reinstall	8522 1900	See SRT
	Fluid level sensor remove + reinstall	9258 1950	See SRT
	Clean fluid level sensor and adjust solvent concentration	9258 9999	10 TU
	Q3:		
	Front wheel housing liner remove + reinstall	6616 1900	See SRT
	Fluid level sensor remove + reinstall	9258 1950	See SRT
	Clean fluid level sensor and adjust solvent concentration	9258 9999	10 TU



Technical Service Bulletin

S3:		
Noise dampening pan remove + reinstall	1082 1900	See SRT
Fluid level sensor remove + reinstall	9258 1950	See SRT
Clean fluid level sensor and adjust solvent concentration	9258 9999	10 TU
A3 Sedan, A3 e-tron, and A3 Cabriolet:		
Front wheel housing liner remove + reinstall	6616 1900	See SRT
Windshield washer reservoir remove + reinstall	9260 1950	See SRT
Clean fluid level sensor and adjust solvent concentration	9258 9999	10 TU
TT:		
Front wheel housing liner remove + reinstall	6616 1900	See SRT
Windshield washer reservoir remove and reinstall	9260 1950	See SRT (2012 – 2015) See SRT (2016 – 2019)
Fluid level sensor remove + reinstall, clean fluid level sensor and adjust solvent concentration	9258 9999	20 TU
R8 (up to and including MY 2015):		
Plenum cover remove + reinstall	8522 1900	See SRT
Fluid level sensor remove + reinstall	9258 1950	See SRT
Clean fluid level sensor and adjust solvent concentration	9258 9999	10 TU
R8 (From MY 2017 on):		
Plenum cover remove + reinstall	8522 1900	See SRT
Fluid level sensor remove + reinstall	9258 1950	See SRT
Clean fluid level sensor and adjust solvent concentration	9258 9999	10 TU



Technical Service Bulletin



	A4 (up to and including MY 2016), A4 avant (up to and including MY 2016), allroad (up to and including MY 2016), A5, A5 Cabriolet (up to and including MY 2017), A6, A7, A8 (up to and including MY 2018) and Q5 (Model 8R, up to and including MY 2017):		
	Fluid level sensor remove + reinstall	9258 1900	See SRT
	Clean fluid level sensor and adjust solvent concentration	9258 9999	10 TU
	A4 (MY 2017 on), A4 avant (MY 2017 on), A4 allroad (MY 2017 on), A5, A5 Cabriolet (Model F5, MY 2018 on), and Q5 (Model FY, MY 2018 on):		
	Front wheel housing liner remove and reinstall	6616 1900	See SRT
	Fluid level sensor remove + reinstall	9258 1950	See SRT
	Clean fluid level sensor and adjust solvent concentration	9258 9999	10 TU
	A6, A7, and A8 (MY 2019 on):		
	Front wheel housing liner remove and reinstall	6616 1900	See SRT
	Fluid level sensor remove + reinstall	9258 1950	See SRT
	Clean fluid level sensor and adjust solvent concentration	9258 9999	10 TU
	Q8 (MY 2019 on):		
	Cowl panel trim remove and reinstall	66 44 19 00	See SRT
	Fluid level sensor remove + reinstall	9258 1950	See SRT
	Clean fluid level sensor and adjust solvent concentration	9258 9999	10 TU
Diagnostic Time:	GFF	No allowance	0 TU
	Road test prior to service procedure	No allowance	0 TU
	Road test after service procedure	No allowance	0 TU
Claim Comment:	As per TSB #2038151/9		

All warranty claims submitted for payment must be in accordance with the *Audi Warranty Policies and Procedures Manual*. Claims are subject to review or audit by Audi Warranty.





Technical Service Bulletin

Required Parts and Tools

Always check with your Parts Department and/or ETKA for the latest information and parts bulletins.		
Part Number	Part Description	Quantity
T10007A	Refractometer 	01
G052164M2	Windshield cleaner concentrate with anti-freeze 	01
Item # 121133 / Customer Item # WWFDRUM (Available from the Audi Top Service Supplies & Touch- Up Paint eStore)	Washer solvent alternative for states with VOC restrictions	Shop Supplies



Technical Service Bulletin

		
D00940104	All-purpose cleaner 	0.1
See ETKA	Fasteners, Bolts, Nuts and Screws as needed per the Repair Manual	See ETKA/ELSA

Additional Information

All parts and service references provided in this TSB (2038151) are subject to change and/or removal.

©2019 Audi of America, Inc. All rights reserved. Information contained in this document is based on the latest information available at the time of printing and is subject to the copyright and other intellectual property rights of Audi of America, Inc., its affiliated companies and its licensors. All rights are reserved to make changes at any



Technical Service Bulletin

time without notice. No part of this document may be reproduced, stored in a retrieval system, or transmitted in any form or by any means, electronic, mechanical, photocopying, recording, or otherwise, nor may these materials be modified or reposted to other sites without the prior expressed written permission of the publisher.