



AUSTRALIA, BAHAMAS, BOLIVIA, BRAZIL, BELIZE, CANADA, CHILE, TAIWAN, COLOMBIA, COSTA RICA, DOMINICAN REPUBLIC, ECUADOR, EL SALVADOR, TRINIDAD AND TOBAGO, UNITED STATES, URUGUAY, VENEZUELA, MEXICO, ARUBA, NICARAGUA, PERU, Curaçao, GUAM, GUATEMALA, GUYANA, HAITI, HONDURAS, JAMAICA, KOREA, SOUTH KOREA, PANAMA, SOUTH AFRICA

Countries: ISIS, FleetISIS, IsSIR

Availability: ISIS, FleetISIS, IsSIR

Major System: ELECTRICAL SYSTEM

Current Language: English

Other Languages: [Français](#), [Español](#).

Viewed: 14352

Document ID: IK0800085

Revision: 11

Created: 4/29/2007

Last Modified: 3/14/2019

Author: Charles Schroeder

[Less Info](#)

Hide Details

Coding Information

Copy Link 	Copy Relative Link 	Bookmark View My Bookmarks	Add to Favorites 	Print 	Provide Feedback 	Helpful 2002	Not Helpful 2075
----------------------	-------------------------------	--	-----------------------------	------------------	-----------------------------	----------------------------	--------------------------------

Title: ProStar Electrical System Load Shed Feature 08XEV

Applies To: ProStar with feature 08XEV Load Shed

Change Log

Please refer to the change log text box below for recent changes to this article:

03/14/2019 - Added note for not setting load shed under 11.8v
 01/07/2019 - Updated all graphics.
 08/16/2017 - Author updated for feedback purposes.
 06/24/2015 - Author updated for feedback purposes.

Description

Electrical Load Control and Shedding (ELCS) is an optional feature (standard w/ sleepers) used to protect the vehicle's batteries from excessive discharge by automatically shutting down electrical loads to conserve battery power. When Load Shed is initiated by the BCM, the relay on the engine cover will open and power to various components will be turned off.

CAUTION:

When troubleshooting ANY electrical issue, you MUST insure the battery voltage is above 12.1. This will ensure Load Shed is off, and all accessories, switch packs, and electronic brake components are powered up.

The Body Controller (BC) monitors the battery voltage at the J6 Power Feed connector of the BC (this is where the big red power cable connects to the BC) and when battery voltage drops below 12.1 volts for 30 seconds:

1. The operator will receive an audible and visual indication that load shedding is about to disable electrical loads. The gauge cluster will display the message "Load Shedding" in the LCD display and the cluster will emit 5 short beeps
2. The Accessory loads will be shut off by the BC sending a momentary 12v to pin C of the Load Shedding relay (Malone relay). This will cause the relay to open the circuit between pins B1 and B2 of the Load Shedding relay. Refer to circuit diagram below.

NOTE:

It is not recommended to set Load Shed (Electrical Load Control) below 11.8v

Symptoms

- Loss of accessory powered items:
- Compass
- Bendix / Meritor Collision Avoidance System Displays and Front Radar
- All Switch Packs
- Tire Pressure Diagnostic
- Task Lighting
- Spot Light
- Work Lights
- Cigar Lighting System

- HVAC Rear Aux Unit
- Refrigerator - Some models also include a low battery voltage shut down
- Video Entertainment
- Power Amp for Subwoofer
- Motorized Mirrors
- Heated Mirrors
- Customer Electrical Accessory Accommodation
- Heated Seats
- Fuel Heater (DC version only)
- Air Dryer and Drain Valve Heating
- Data Logger / Event Recorder
- Courtesy Lights
- Accent Lights
- Air Shield Light
- Running Lights
- Fog Lights
- Floor Lights
- Secondary Display (SD)
- Secondary Instrument Cluster (SIC)
- Engine Monitors
- Prognostic and Diagnostic Module

Possible Diagnostic Trouble Codes

SPN	FMI	Module	Description
520705	5	Body Controller	Load Shed OFF Relay Under Current Or Open Circuit
520705	6	Body Controller	Load Shed OFF Relay Over Current
520706	5	Body Controller	Load Shed ON Relay Under Current Or Open Circuit
520706	6	Body Controller	Load Shed ON Relay Over Current

Troubleshooting



While troubleshooting, never apply 12v to the Malone relay input terminals A and C for longer than one second. This is a latching relay and only requires voltage for 20 milliseconds to change states. If you apply 12v for longer than one second, you will burn up the relay.

1. Check for diagnostic trouble codes using DLB.
 - For instructions on how to do this properly, please follow [IK0800399 - How To Export DLB Fault Codes To Attach To A Case File](#)
2. Check battery voltage at the batteries with a multimeter.
3. Check the voltage at the J6 Power Feed connector of the BC (this is where the big red power cable connects to the BC) with a multimeter. For location of this, refer to Figure 2 below.
4. The voltage from Step 2 and Step 3 should be the same. If they aren't you need to trace the wiring and figure out what's causing them to be different.
5. Create a session with the signals below in it.

International® Diamond Logic® Builder												
File Edit View Advanced Logic Tools Diagnostics Help							Simulating - 2H5CUAPR78C467049					
*Unsaved Session												
ESC Signals	Master List	Watched	Graph	Signal	Pins	Signal Type	Value	Unit	Status	Name
				Accessory_Signal_Input	1600-A1	Digital Input	<input checked="" type="checkbox"/>	On/Off	0	<input type="checkbox"/>	<input type="checkbox"/>	Acce...
				Ignition_Signal_Input	1600-A16	Digital Input	<input checked="" type="checkbox"/>	On/Off	0	<input type="checkbox"/>	<input type="checkbox"/>	Igni...
				Load_Shed_Power_Off_RD_Cmd	1601-F6	Relay Driv...		0 Number	0	<input type="checkbox"/>	<input type="checkbox"/>	Load...
				Load_Shed_Power_On_RD_Cmd	1601-F7	Relay Driv...		0 Number	0	<input type="checkbox"/>	<input type="checkbox"/>	Load...
				Engine_Running			<input type="checkbox"/>	On/Off	0	<input type="checkbox"/>	<input type="checkbox"/>	Engi...
				Park_Brake			<input type="checkbox"/>	On/Off	0	<input type="checkbox"/>	<input type="checkbox"/>	Park...
				Battery_Voltage_Signal				14.4V	0	<input type="checkbox"/>	<input type="checkbox"/>	Batt...

6. Compare the Battery_Voltage_Signal in DLB to the reading on your multimeter in Step 2 and Step 3. They should all be the same.

Circuit Diagrams

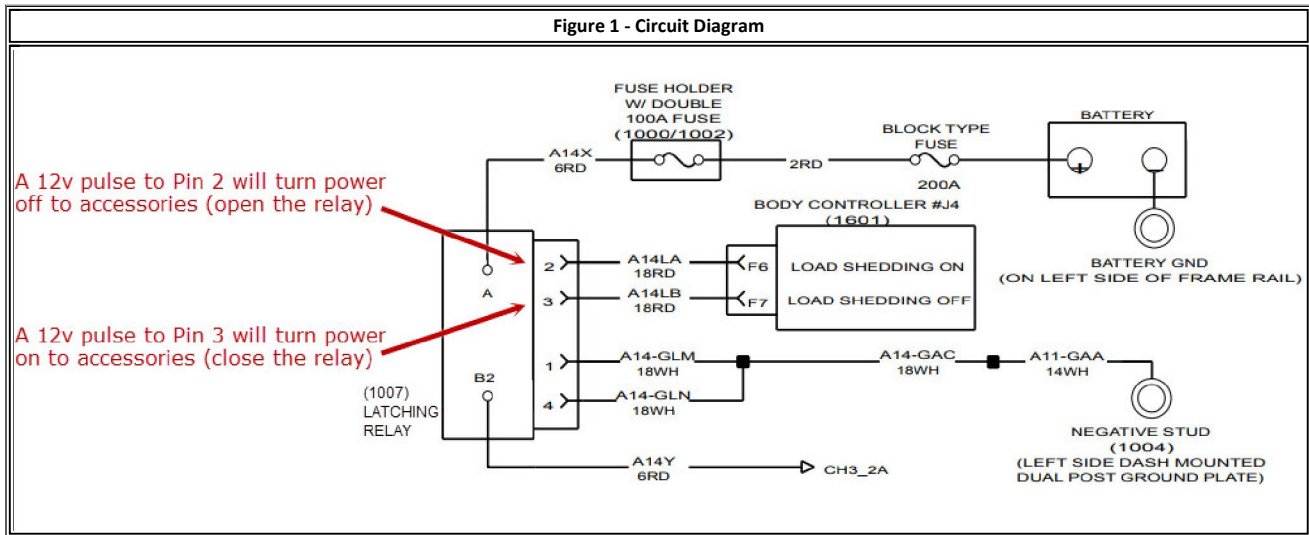

Component Locations

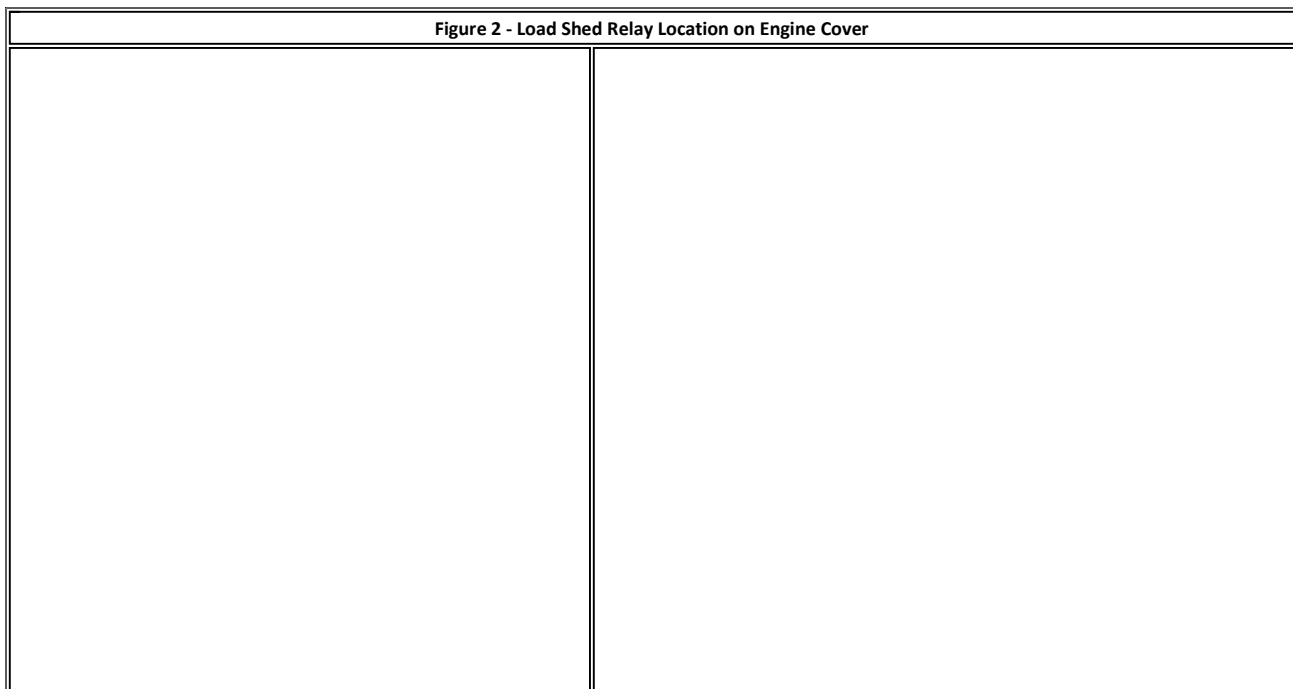

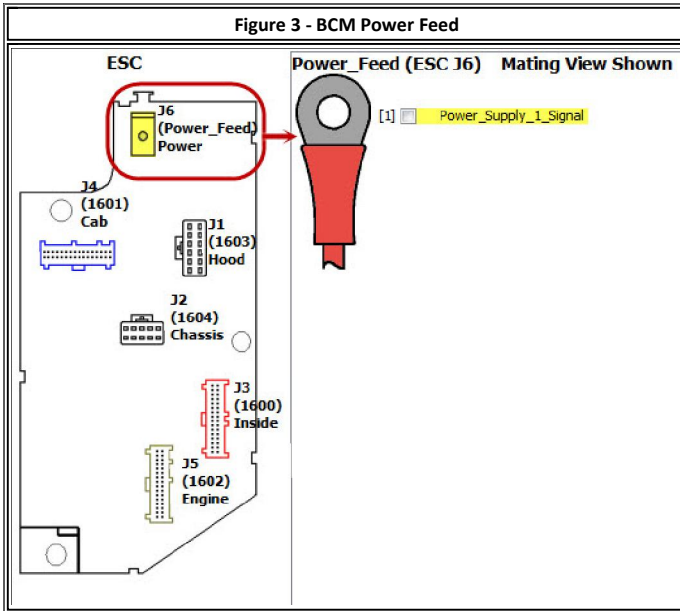
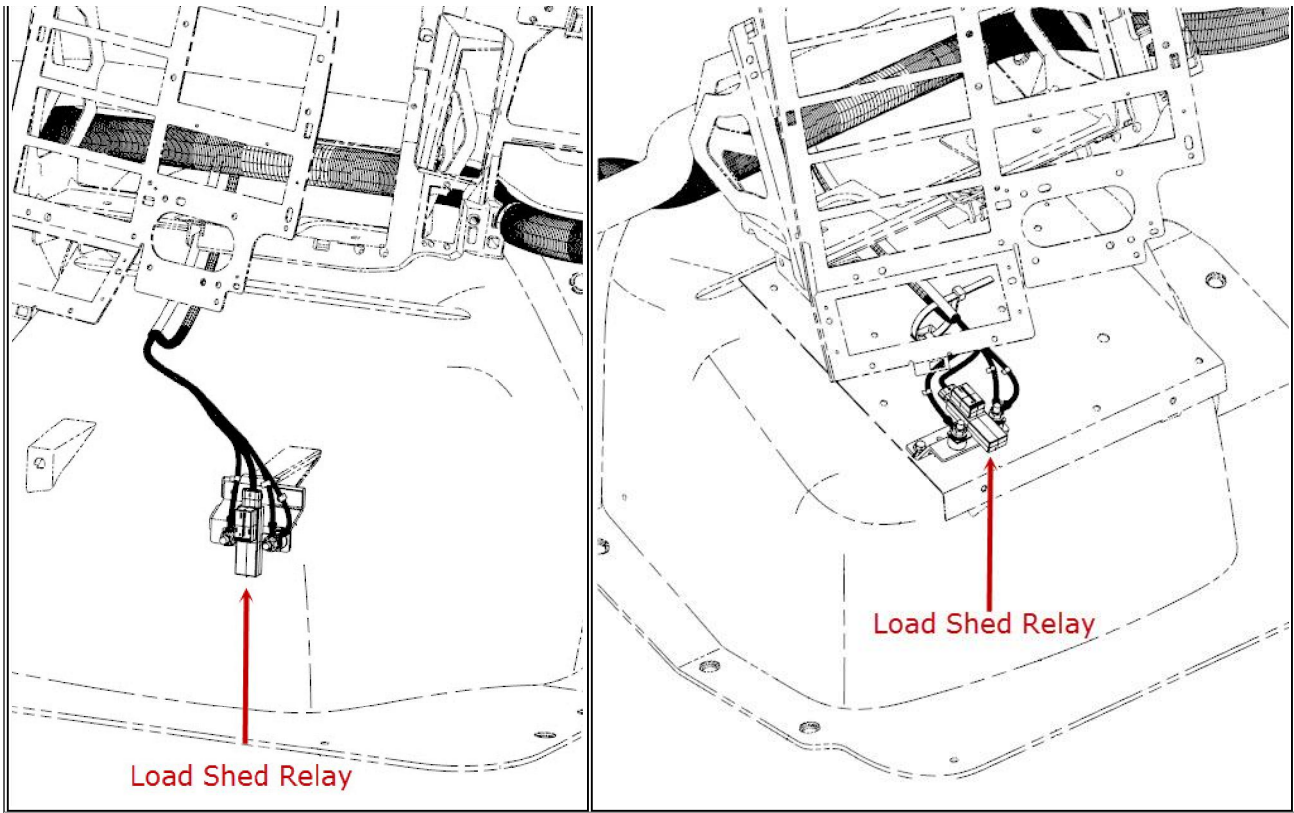

Warranty Information

Warranty Claim Coding:

Refer to the [Warranty Coding Manual](#) for Group and Noun Codes.

Standard Repair Time(s):

Refer to the [SRT Manual](#) for Repair Times

Other Resources

[Master Service Information Site](#)

 Hide Details

Feedback Information

Viewed: 14351
Helpful: 2002
Not Helpful: 2075

No Feedback Found

Copyright © 2019 Navistar, Inc.