



# Service Action

## Code: 51G4

<b>Subject</b>	<b>Seam Sealer Application</b>
<b>Release Date</b>	March 12, 2019
<b>Affected Vehicles</b>	<b>U.S.A. &amp; CANADA: Certain 2019 MY Volkswagen Jetta</b> <i>Check Campaigns/Actions screen in Elsa on the day of repair to verify that a VIN qualifies for repair under this action. Elsa is the <u>only</u> valid campaign inquiry &amp; verification source.</i> <ul style="list-style-type: none"><li>✓ Campaign status must show "open."</li><li>✓ If Elsa shows other open action(s), inform your customer so that the work can also be completed at the same time the vehicle is in the workshop for this campaign.</li></ul>
<b>Problem Description</b>	Affected vehicles may experience a water leak due to improper application of body seam sealer.
<b>Corrective Action</b>	Apply seam sealer over certain exposed seams in the plenum chamber. <b>Please note: For 24 hours after seam sealer application, avoid getting the vehicle wet.</b>
<b>Parts Information</b>	Parts will be managed with a weekly Upper Order Limit. Please see Parts On Command (POC) for your Upper Order Limit quantity. If your dealership is at the weekly Upper Order Limit, please submit the backordered sales document number to <a href="mailto:upperorderlimits@vw.com">upperorderlimits@vw.com</a> to have additional parts released.
<b>Code Visibility</b>	On or about March 12, 2019, affected vehicles will be listed on the Inventory Vehicle Open Campaign Action report under My Dealership Reports (found on <a href="http://www.vw.com">www.vw.com</a> & OMD Web). A list will not be posted for dealers who do not have any affected vehicles.  On or about March 12, 2019, this campaign code will show open on affected vehicles in Elsa.  On or about March 12, 2019, affected vehicles will be identified with this campaign code in the VIN Lookup tool at <a href="http://www.vw.com">www.vw.com</a> .
<b>Owner Notification</b>	Owner notification will take place in March 2019. Owner letter examples are included in this bulletin for your reference.
<b>Campaign Expiration Date</b>	This campaign expires on December 31, 2021. Repairs must be performed on or before this date to be eligible for payment. Keep this expiration date in mind when scheduling customers for this action. If a customer wishes to have this service performed after the expiration date, your dealerships normal parts and labor cost associated with this repair will apply.
<b>Additional Information</b>	<b>Please alert everyone in your dealership about this action, including Sales, Service, Parts and Accounting personnel. Contact Warranty if you have any questions.</b>  Dealers must ensure that every affected inventory vehicle has this campaign completed <u>before delivery to consumers</u> .  Fill out and affix Campaign Completion Label (CAMP 010 000) after work is complete. Labels can be ordered at no cost via the Compliance Label Ordering portal at <a href="http://www.vw.com">www.vw.com</a> .



## Customer Letter Example (USA)

<MONTH YEAR>

<CUSTOMER NAME>

<CUSTOMER ADDRESS>

<CUSTOMER CITY STATE ZIPCODE>

**This notice applies to your vehicle:** <VIN>

**Subject: Service Action 51G4 – Seam Sealer Application  
Certain 2019 MY Volkswagen Jetta**

Dear Volkswagen Owner,

As part of Volkswagen's ongoing commitment to customer satisfaction, we are informing you of our decision to conduct a service action on certain 2019 Volkswagen Jetta vehicles. Our records show that you are the owner of a vehicle affected by this action.

**What is the issue?** On affected vehicles, there may be a water leak due to improper application of body seam sealer.

**What will we do?** Your authorized Volkswagen dealer will apply seam sealer over certain exposed seams in the plenum chamber. This work will take about an hour to complete and will be performed for you free of charge.

***Please note: For 24 hours after seam sealer application, you must avoid getting your vehicle wet.***

**What should you do?** Please contact your authorized Volkswagen dealer as soon as possible to schedule this service. To set up an appointment online, please visit [www.vw.com/find-a-dealer](http://www.vw.com/find-a-dealer).

This service action will be available for you **free of charge only until December 31, 2021**. If you wish to have this service performed after that date, your dealer's normal parts and labor cost associated with this repair will apply.

**Lease vehicles and address changes** If you are the lessor and registered owner of the vehicle identified in this action, please forward this letter immediately via first-class mail to the lessee within ten (10) days of receipt. If you have changed your address or sold the vehicle, please fill out the enclosed prepaid Owner Reply card and mail it to us so we can update our records.

**Can we assist you further?** If your authorized Volkswagen dealer fails or is unable to complete this work free of charge within a reasonable time, or if you should have any questions about this communication, please reach out to us using your preferred method of communication at [www.vw.com/contact](http://www.vw.com/contact) or by calling us at 800-893-5298.

**Checking your vehicle for open Recalls and Service Campaigns** To check your vehicle's eligibility for repair under this or any other recall/service campaign, please visit [www.vw.com/owners/recalls](http://www.vw.com/owners/recalls) and enter your Vehicle Identification Number (VIN) into the Recall/Service Campaign Lookup tool.

We apologize for any inconvenience this matter may cause; however we are taking this action to help ensure your vehicle continues to meet and exceed your expectations.

Sincerely,

Volkswagen Customer Protection

## Customer Letter Example (CANADA)

<MONTH YEAR>

<CUSTOMER NAME>

<CUSTOMER ADDRESS>

<CUSTOMER CITY STATE ZIPCODE>

**This notice applies to your vehicle:** <VIN>

**Subject: Service Action 51G4 – Seam Sealer Application  
Certain 2019 MY Volkswagen Jetta**

Dear Volkswagen Owner,

As part of Volkswagen's ongoing commitment to customer satisfaction, we are informing you of our decision to conduct a service action on certain 2019 Volkswagen Jetta vehicles. Our records show that you are the owner of a vehicle affected by this action.

**What is the issue?** On affected vehicles, there may be a water leak due to improper application of body seam sealer.

**What will we do?** Your authorized Volkswagen dealer will apply seam sealer over certain exposed seams in the plenum chamber. This work will take about an hour to complete and will be performed for you free of charge.

***Please note: For 24 hours after seam sealer application, you must avoid getting your vehicle wet.***

**What should you do?** In order to limit any possible inconvenience, please contact your authorized Volkswagen dealer as soon as possible to schedule this service. Please keep in mind that your dealer may need additional time for the preparation of the repair, as well as to accommodate their daily workshop schedule.

This service action will be available for you free of charge only until December 31, 2021. If you wish to have this service performed after that date, your dealer's normal parts and labor cost associated with this repair will apply.

**Lease vehicles and address changes** If you are the lessor and registered owner of the vehicle identified in this action, please forward this letter immediately via first-class mail to the lessee within ten (10) days of receipt. If you have changed your address or sold the vehicle, please fill out the enclosed prepaid Owner Reply card and mail it to us so we can update our records.

**Can we assist you further?** If your authorized Volkswagen dealer fails or is unable to complete this work free of charge within a reasonable time, please contact Customer Relations, Monday through Friday from 8AM to 8PM EST by phone at 1-800-822-8987 or via our "Contact Us" page at [www.vw.ca](http://www.vw.ca).

We apologize for any inconvenience this matter may cause; however we are taking this action to help ensure your vehicle continues to meet and exceed your expectations.

Sincerely,

Volkswagen Customer Protection

Repair Overview

**NOTE**

- These repair instructions may differ from the labor operations and labor times listed in ELSA.
- Damages resulting from improper repair or failure to follow these work instructions are the dealer's responsibility and are not eligible for reimbursement under this action.
- This procedure must be read in its entirety prior to performing the repair.
- Due to variations in vehicle equipment and options, the steps/illustrations in this work procedure may not identically match all affected vehicles.
- Diagnosis and repair of pre-existing conditions in the vehicle are not covered under this action.
- When working during extreme temperatures, it is recommended that the vehicle be allowed to acclimate inside the shop to avoid temperature-related component damage/breakage.

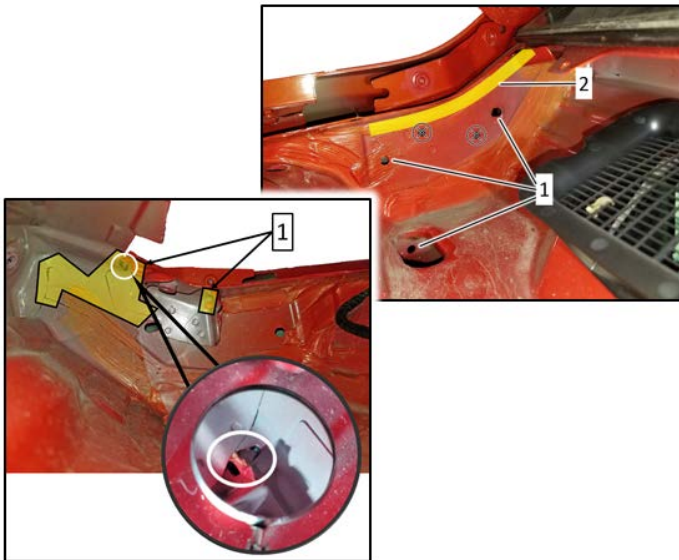

- Apply seam sealer to exposed seams in the plenum chamber.

## Required Parts

Part Description	Part No:	Quantity
Seam Sealer (grey)	D 476.KD1.M2	One canister will repair approxiamtely 12 cars.
-OR- (either part number may be used)		
Seam Sealer (black)	D 476.KD2.M2	
-OR-		
Part Description	3M Part No:	Quantity
3M Seam Sealer (locally sourced)	08369*	One container will repair approxiamtely 12 cars. *(If 3M seam sealer is used, a special applier gun is not required. Place a small cut in the package and reseal using a resealable bag)
	-OR-	
	08370*	
	-OR-	
	08374	

### ! NOTE

The specified part numbers reflect the status at the start of this service action. Interim updates made in ETKA can cause a listed part number to become unavailable. In this case, the new part number specified in ETKA should be used.

## Required Tools

	<p>Puller - Wiper Arm Kit - Puller 1 -T10369/1-</p>		<p>Torque Wrench 5-50Nm -VAG1331- (or equivalent)</p>
---	---	--	---

## Repair Instruction

### Section A - Check for Previous Repair

#### TIP

If Campaign Completion label is present, no further work is required.

Applicable criteria ID(s)	Campaign/Action Status
01 ← <b>2</b>	Open ← <b>1</b>

**EXAMPLE**

- Enter the VIN in Elsa and proceed to the “Campaign/Action” screen.

#### TIP

On the date of repair, print this screen and keep a copy with the repair order.

- Confirm the Campaign/Action is open <arrow 1>. If the status is closed, no further work is required.
- Note the Applicable Criteria ID <arrow 2> for use in determining the correct work to be done and corresponding parts associated.

**Proceed to Section B**

## Section B – Repair Procedure

### NOTE

If moisture is found in the interior of the vehicle, diagnosis and repair as needed following normal warranty policy. Any additional repair work must be submitted on a separate warranty claim.

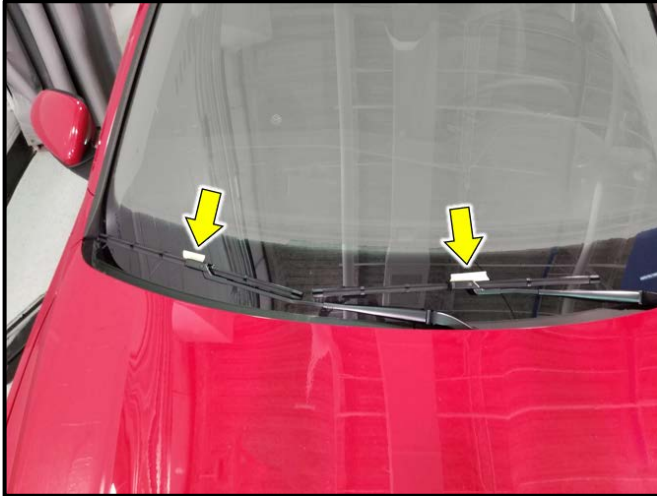

### Mark wiper park position.

- Mark the wiper park position with tape <arrows> or other means.

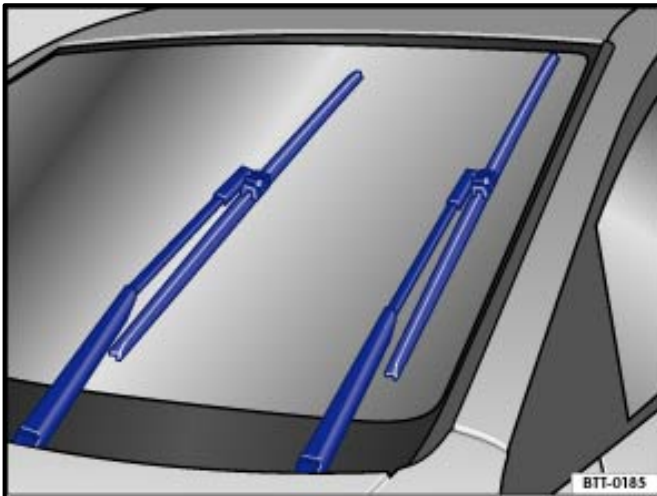

### Put wipers in service position.

- The hood must be closed.
- Briefly turn the ignition on and then off again.
- Turn the windshield wiper lever in the “one-touch wiping position” within 10 seconds.

### NOTE

Wipers must be in service position in order to remove wiper linkage.



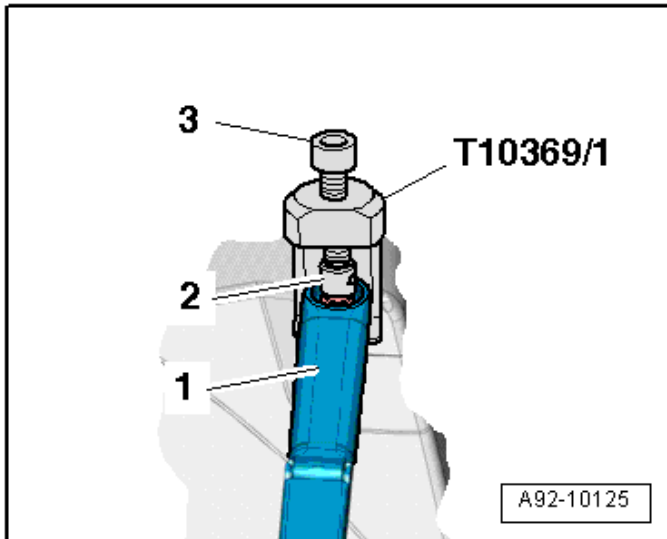

### Remove left and right wiper arms.

- Pry off cap with a small screwdriver.
- Remove nut.
- Position the -T10369/1- on the windshield wiper arm <1> as shown.
- Position the thrust piece <2> on the wiper arm shaft.
- Turn the bolt <3> clockwise until the windshield wiper arm <1> is removed from the wiper arm shaft.
- Remove the nut completely and remove the windshield wiper arm <1>.

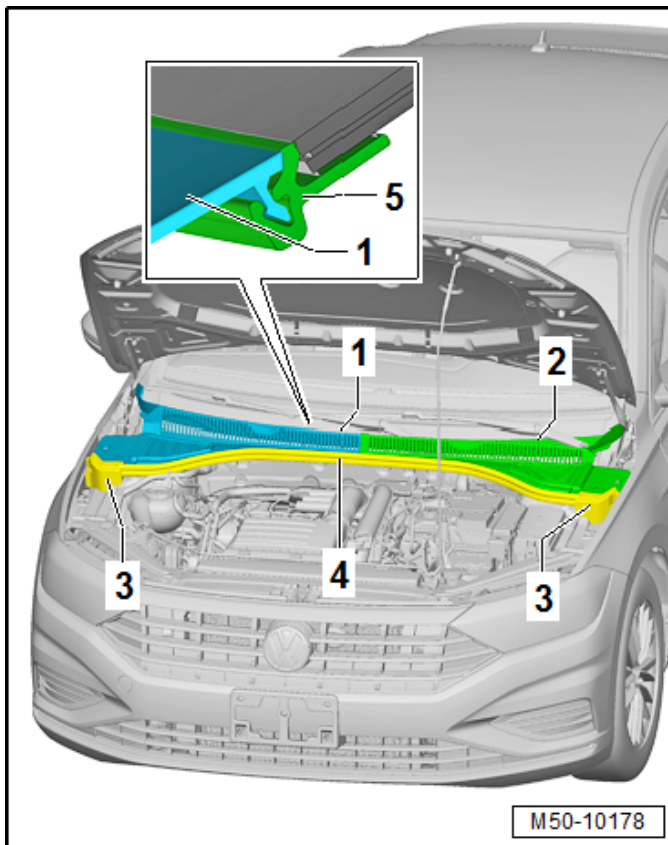

### Remove plenum chamber covers <1 and 2>:

- Remove the seal <4> forward from the plenum chamber covers <1 and 2>.
- Remove the left and right foam piece <3> from the plenum chamber covers <1 and 2>.
- Remove clip for washer hose from left plenum chamber cover.
- Remove the left plenum chamber cover <2> upward from the retainer <5>.
- Remove the right plenum chamber cover <1> upward from the retainer <5>.

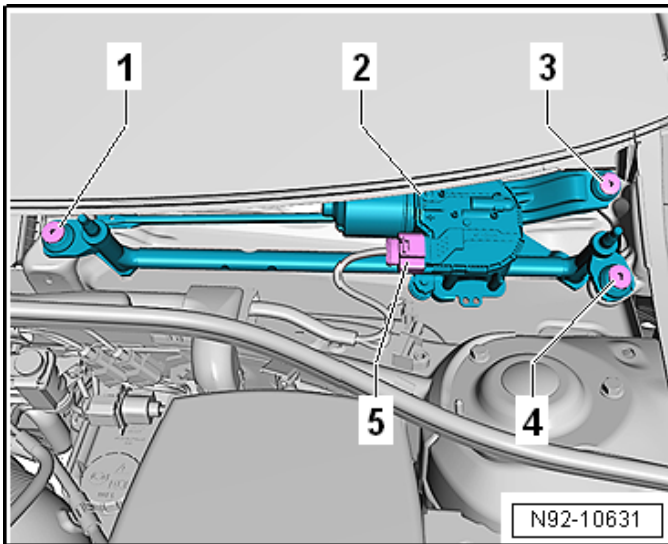

### Remove wiper linkage and motor.

- Disconnect connector <5>.
- Remove bolts <1, 3 and 4>.
- Remove the wiper frame <2> with linkage and wiper motor from the plenum chamber.

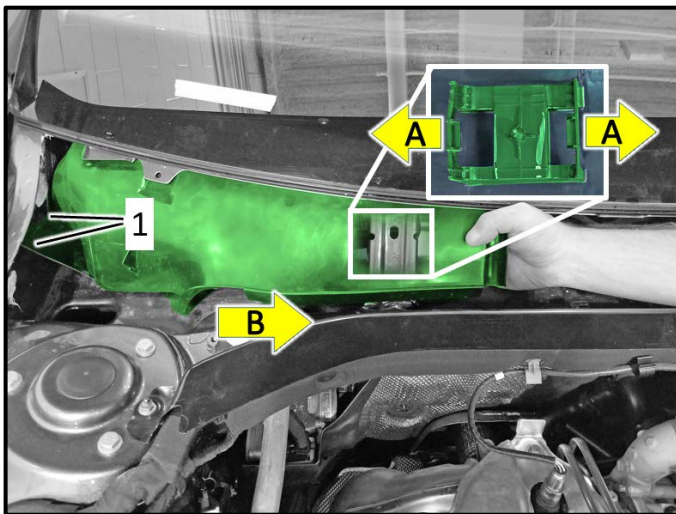

### Remove HVAC fresh air intake water deflector.

- Reach under the deflector and release locking tabs in direction of <arrows A>.
- Pull deflector up slightly from the plenum chamber and remove off of mounts <1> in direction of <arrow B>.

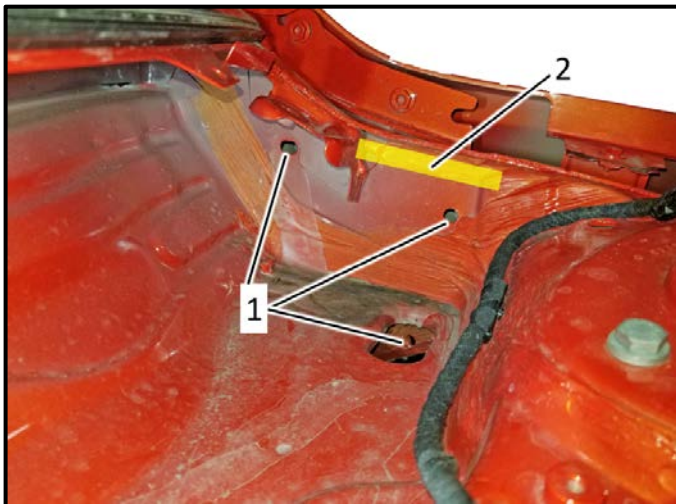

### Apply seam sealer driver side.

- Use a gloved finger or a small brush to apply the seam sealer.
- Ensure area is dry.
- Completely cover holes <1> with sealer.

#### **NOTE**

Do not cover the large plenum chamber drain.

- Completely cover exposed seams in the shaded area <2>.

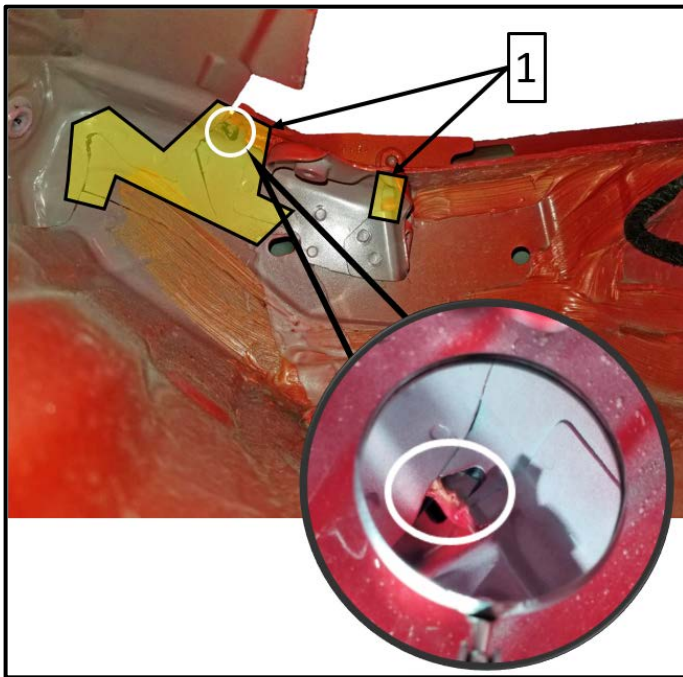

### Apply seam sealer driver side (cont.)

- Ensure area is dry.
- Apply the seam sealer to the exposed seams in the shaded areas <1>.
  - Use a small mirror to locate the area shown in the inset photo <circle> and completely seal any openings.

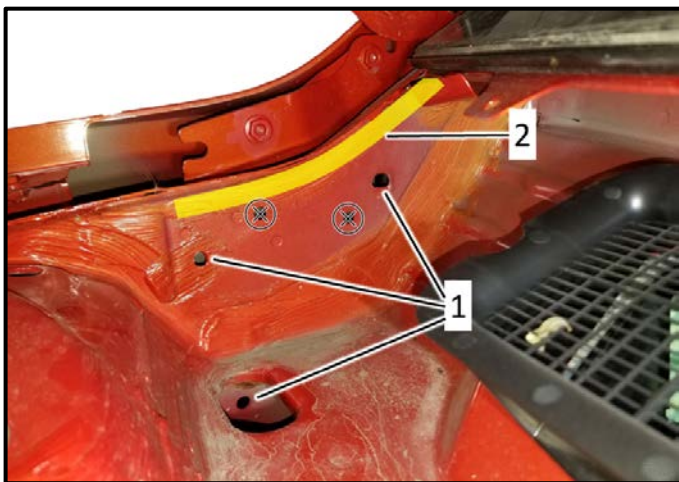

### Apply seam sealer passenger side.

- Use a gloved finger or a small brush to apply the seam sealer.
- Ensure area is dry.
- Completely cover holes <1> with sealer.

#### NOTE

- Do not cover the large plenum chamber drain.
  - Do not cover the holes for the water deflector.
- Completely cover exposed seams in the shaded area <2>.

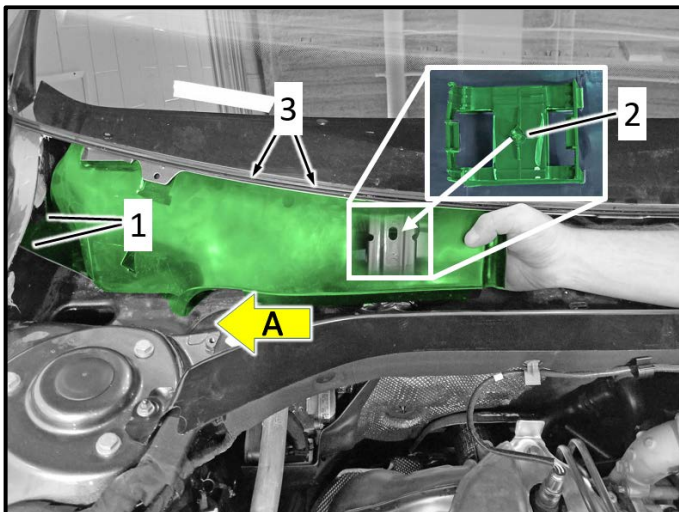

### Install HVAC fresh air intake water deflector.

- Line up mounts <1> and install deflector in direction of <arrow A>.
- Line up pin <2> with the hole on the plenum chamber bracket and clip deflector in place.
- The deflector must be installed underneath the plenum chamber cover retainer <3>.

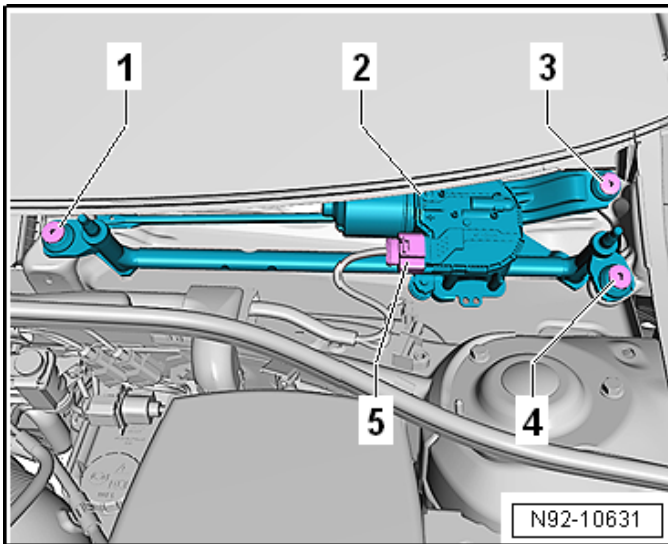

### Install wiper linkage and motor.

- Hand tighten bolts in sequence <4 - 3 - 1>.
- Torque bolts in sequence <4 - 3 - 1> to 8 Nm.
- Connect connector <5>.

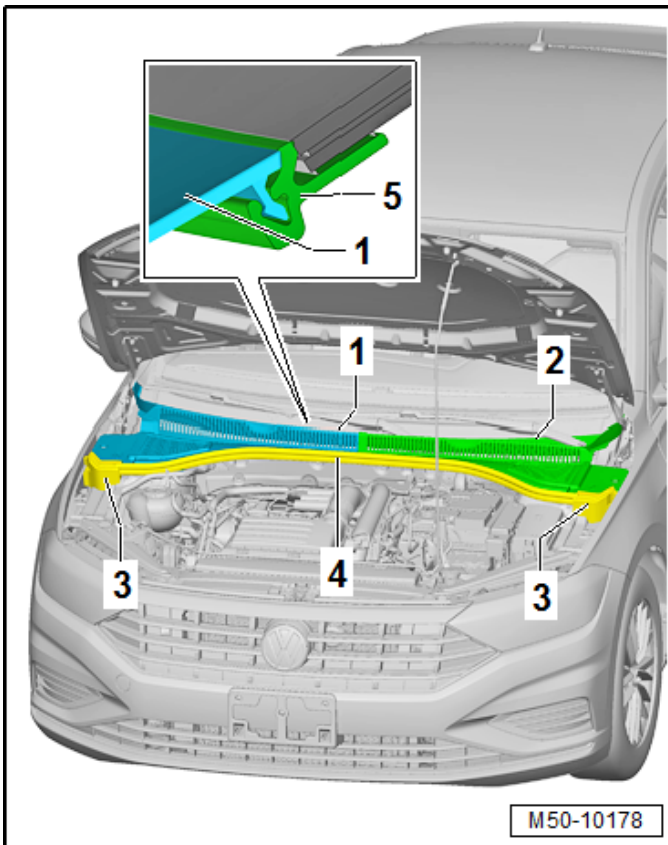

### Install plenum chamber covers.

- Spray the retainer <5> with soapy water so that the plenum chamber covers <1 and 2> can be clipped in more easily.
- Place the plenum chamber cover <1> on the retainer <5>. Starting at the outside, gently push it into the retainer <5>.
- Place the plenum chamber cover <2> on the retainer <5>. Starting at the outside, gently push it into the retainer <5>.
- Install the seal <4>.
- Install the left and right foam piece <3>.
- Install clip for washer hose onto left plenum chamber cover.

### NOTE

Striking the plenum chamber cover into the windshield retainer may cause the windshield to crack. Damage to the windshield or plenum chamber covers will not be covered under this action.

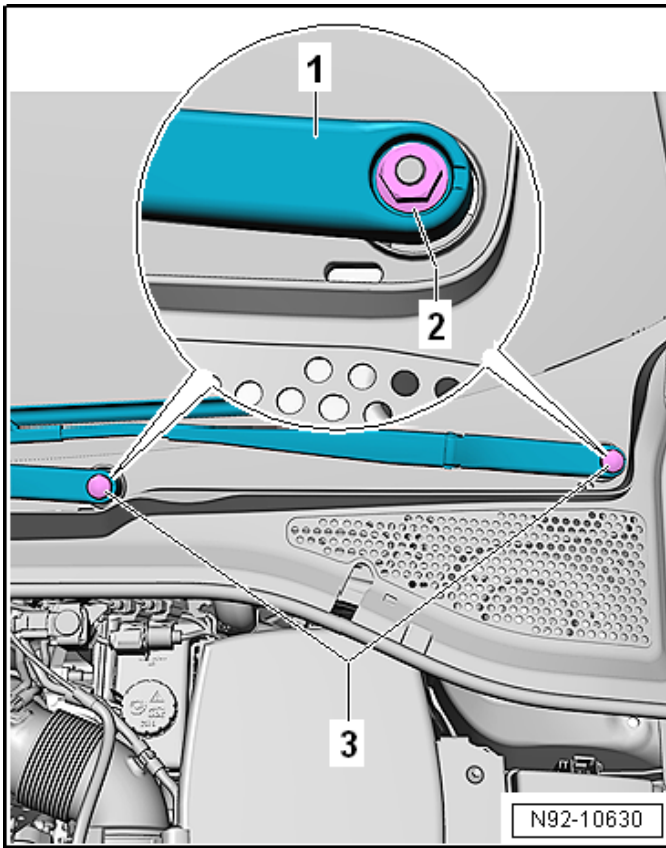

### Take wipers out of service position.

- Close the hood.
- Turn ignition on.
- Operate wipers and then turn wipers to the off position.
- Turn ignition off.

### Install left and right wiper arms.

- Open the hood.
- Reference previously made marks and install wiper arms on wiper linkage studs.
- Install nuts <2> and torque to 20 Nm.
- Install caps <1>.
- Close the hood.
- Turn ignition on and verify wiper operation.



- After seam sealer is applied, the vehicle cannot be washed, be in the rain or get wet for 24 hours to allow for proper curing of the seam sealer.

#### NOTE

Temperature does not affect curing time.

**Work is complete - Proceed to Section C.**

## Section C – Campaign Completion Label

### Install Campaign Completion Label

- Fill out and affix Campaign Completion Label, part number CAMP 010 000, next to the vehicle emission control information label.

 **TIP**

Ensure Campaign Completion Label does not cover any existing label(s).