

# Lack of A/C Performance at Idle in High Ambient Temperature

**Service Category** Vehicle Interior

**Section** Heating/Air Conditioning

**Market** USA

Toyota Supports  
 ASE Certification 

## Applicability

YEAR(S)	MODEL(S)	ADDITIONAL INFORMATION
2015	Tacoma	VDS(s): JU4GN, KU4HN, LU4EN, MU4FN, TU4GN, UU4EN Engine(s): 1GR Transmission(s): 5AT

### REVISION NOTICE

February 13, 2019 Rev1:

- Applicability has been updated to include engine and transmission type.
- The Warranty Information section has been updated.

Any previous printed versions of this bulletin should be discarded.

## Introduction

Some 2015 model year Tacoma vehicles may exhibit a condition where the air conditioning system shuts down and stops blowing cool air during periods of extended engine idle with ambient temperatures greater than 100° Fahrenheit. Follow the Repair Procedure in this bulletin to address this condition.

## Warranty Information

OP CODE	DESCRIPTION	TIME	OFF	T1	T2
AC1901	Additional Cooling Kit	1.6	16410-0P030	7A	99

### APPLICABLE WARRANTY

- This repair is covered under the Toyota Basic Warranty. This warranty is in effect for 36 months or 36,000 miles, whichever occurs first, from the vehicle's in-service date.
- Warranty application is limited to occurrence of the specified condition described in this bulletin.

## Lack of A/C Performance at Idle in High Ambient Temperature

### Parts Information

PART NUMBER		PART NAME	QTY
PREVIOUS	NEW		
N/A	04000-17235	SSP, Cooling Kit	1

### Repair Procedure

**NOTE**

This procedure includes the installation of an additional condenser cooling fan and an updated A/C pressure switch. The installation of these parts also requires the installation of a sub-wire harness and an additional relay block.

1. Does the vehicle A/C system shut OFF while idling in Drive during high ambient temperature (100°F+) for a prolonged period of time?

**CAUTION**

- Ensure that the parking brake is firmly applied and hold your foot on the brake pedal.
- Conduct activity in an open area away from obstacles.

**NOTE**

The condition may NOT be possible to duplicate if ambient temperature is below 100°F.

- **YES** — Go to step 3.
  - **NO** — Continue to step 2.
2. If unable to duplicate the condition in step 1, confirm that the vehicle condition is similar to the condition described in step 1.  
Is the condition similar to the condition described in step 1?
    - **YES** — Continue to step 3.
    - **NO** — This bulletin does NOT apply. Continue diagnosis using the applicable Repair Manual.
  3. Discharge the air conditioning system.  
Refer to TIS, applicable model and model year Repair Manual:
    - 2015 Tacoma:  
*Vehicle Interior – Heating/Air Conditioning – [“Air Conditioning: Refrigerant: Replacement”](#)*

## Lack of A/C Performance at Idle in High Ambient Temperature

### Repair Procedure (continued)

4. Remove the radiator grille.
  - A. Disconnect and remove the battery.
  - B. Remove the two screws holding the grille in place.
  - C. Using a clip remover, remove the two clips.
  - D. Disengage the eight guides and remove the radiator grille.

**Figure 1.**

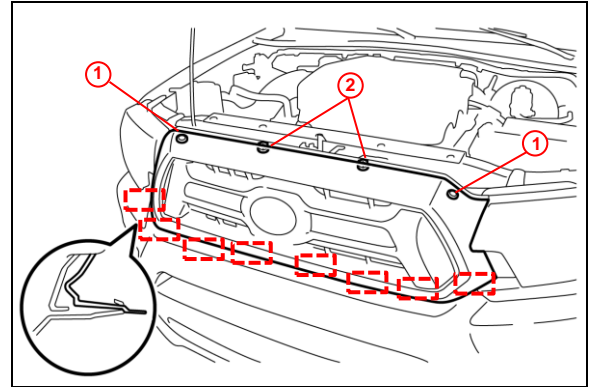

<b>1</b>	<b>Clip</b>
<b>2</b>	<b>Screw</b>
	<b>Guide</b>

5. Remove the hood lock release lever protector shroud by removing the two bolts.

**Figure 2.**

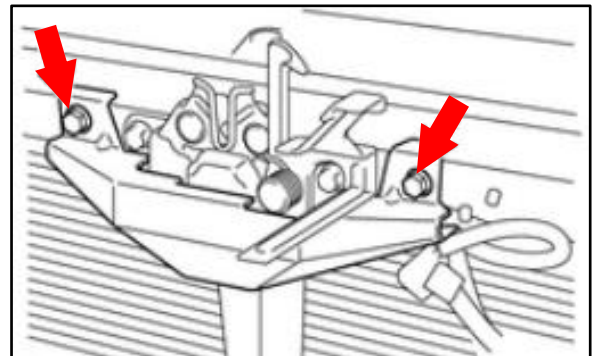

## Lack of A/C Performance at Idle in High Ambient Temperature

---

### Repair Procedure (continued)

6. Modify the hood lock release lever protector.
  - A. Using sheet metal shears, trim the bottom of the protector which shares the attachment with the pusher fan.

**Figure 3. Measure 40 mm**



**Figure 4. Measure 10 mm**

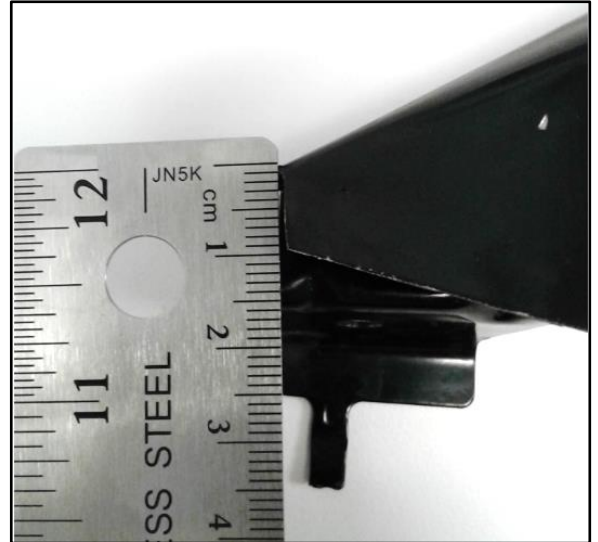

**Figure 5. Trimmed Protector**



## Lack of A/C Performance at Idle in High Ambient Temperature

### Repair Procedure (continued)

- B. Bend the locating tab up for fan clearance.

**Figure 6.**

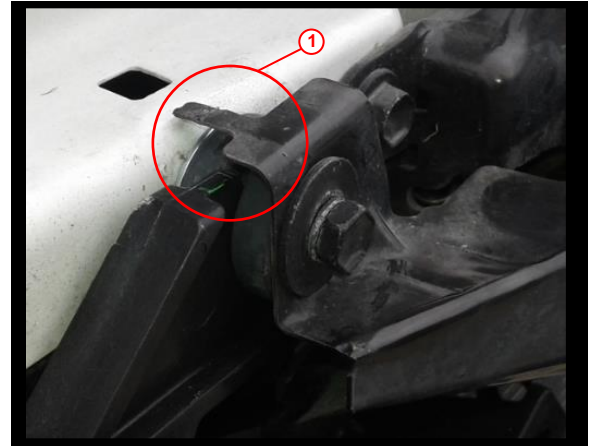

<b>1</b>	<b>Bend Here</b>
----------	------------------

- 7. Modify the additional condenser fan for the automatic transmission oil cooler.

**Figure 7.**



**Figure 8.**

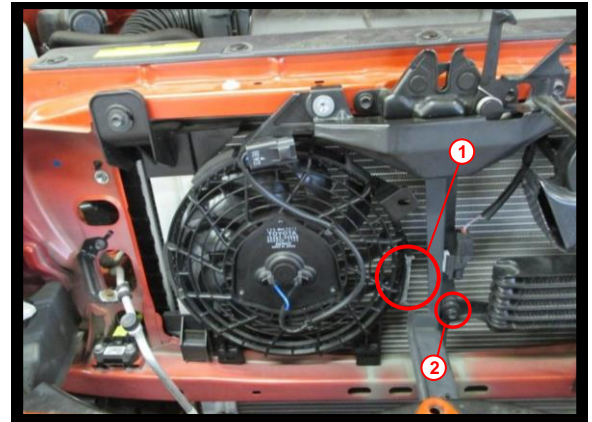

<b>1</b>	<b>Fan Bracket</b>
<b>2</b>	<b>Automatic Transmission Cooler Mount</b>

## Lack of A/C Performance at Idle in High Ambient Temperature

### Repair Procedure (continued)

8. Cut off the side bracket to eliminate interference with the automatic transmission cooler mount.
  - A. Gently hold the base mount of the condenser fan in a vise.

**Figure 9.**

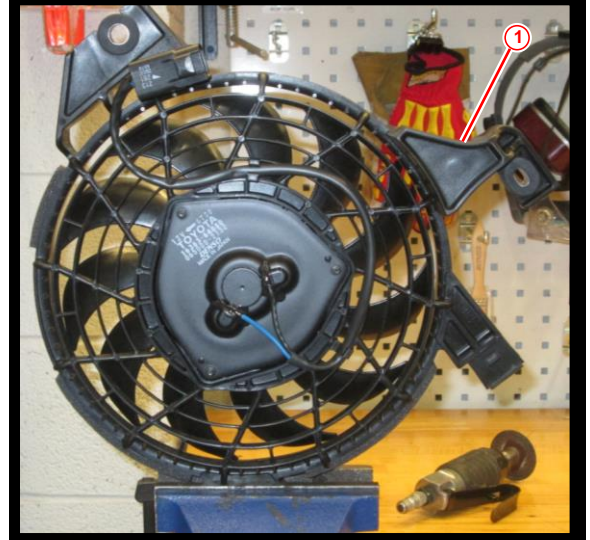

<b>1</b>	<b>Side Bracket</b>
----------	---------------------

- B. Using an abrasive cutting wheel or similar cutting tool, cut off the right side mount.

**Figure 10.**

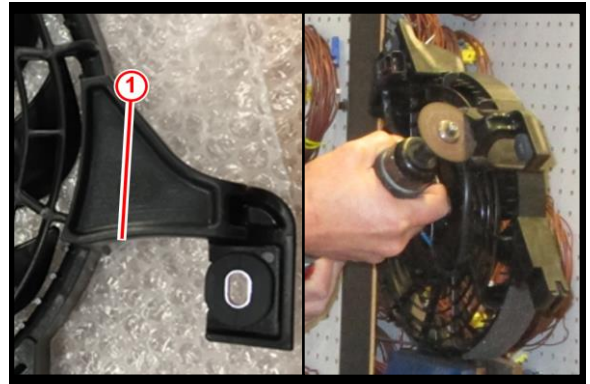

<b>1</b>	<b>Trim Here</b>
----------	------------------

## Lack of A/C Performance at Idle in High Ambient Temperature

### Repair Procedure (continued)

- C. Measure 25 mm from the top of the mount and cut off the remaining portion.

**Figure 11.**



<b>1</b>	<b>25 mm</b>
----------	--------------

- D. Clean off ANY remaining plastic burrs from the cut surface.

**Figure 12.**

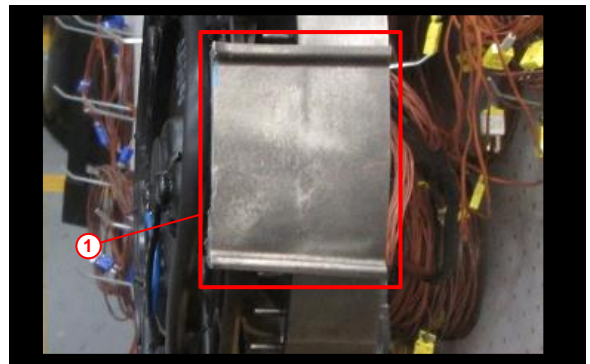

<b>1</b>	<b>Finished Mount Modification</b>
----------	------------------------------------

## Lack of A/C Performance at Idle in High Ambient Temperature

### Repair Procedure (continued)

9. Install the condenser fan and hood lock release lever protector.
  - A. Slide the two bottom mounts of the condenser fan over the sheet metal lip of the radiator core support.
  - B. Remove the bolt from the rubber grommet at the top mounting location.

**Figure 13.**

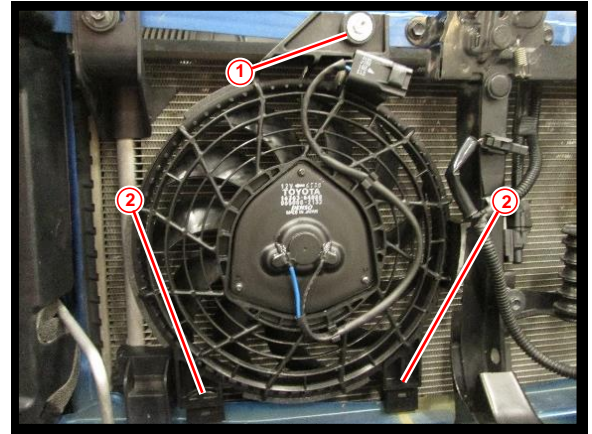

<b>1</b>	<b>Bolt</b>
<b>2</b>	<b>Bottom Mount</b>

- C. Place the hood lock release lever protector over the rubber grommet and install the bolts as shown.

**Figure 14.**

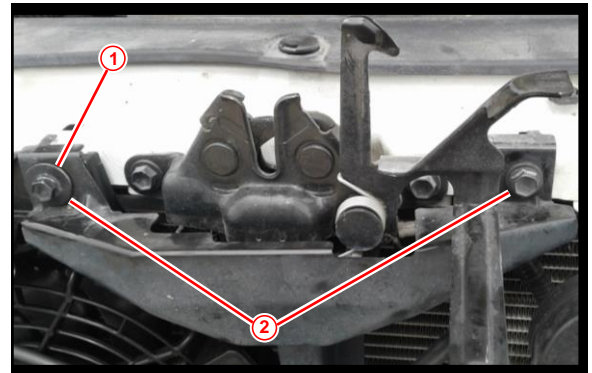

<b>1</b>	<b>Rubber Grommet</b>
<b>2</b>	<b>Bolt</b>



## Lack of A/C Performance at Idle in High Ambient Temperature

### Repair Procedure (continued)

10. Remove the engine room relay block cover. Unplug the engine wire harness connector EA1 and engine room main wire EB1.

**Figure 15.**

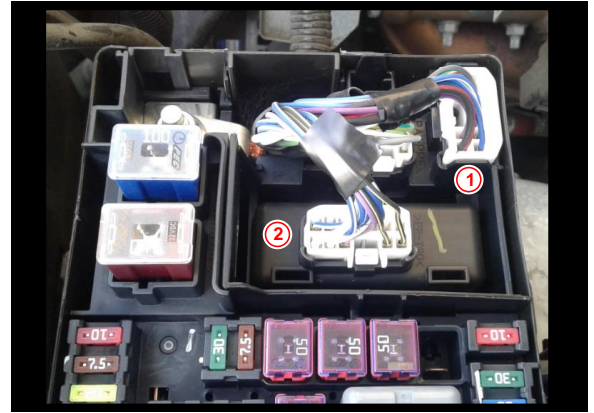

<b>1</b>	<b>EA1 Connector</b>
<b>2</b>	<b>EB1 Connector</b>

11. Pull the wire harness from the relay block by sliding the connector up.

**Figure 16.**



## Lack of A/C Performance at Idle in High Ambient Temperature

### Repair Procedure (continued)

12. Release the pin lock from the EA1 connector using a terminal removal tool.

Figure 17.

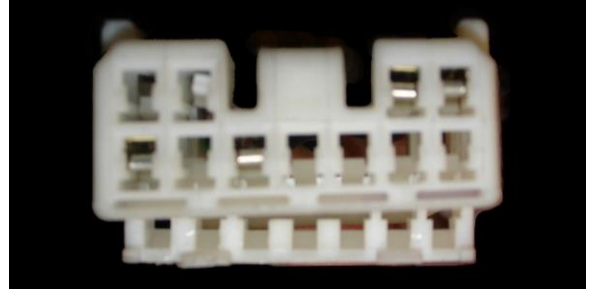

13. Remove pin No. 3 (purple wire) from the EA1 connector.

Figure 18.

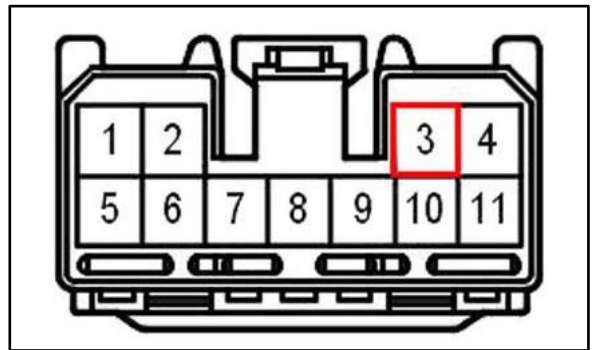

14. Remove the female terminal (purple wire) from the 1 pin sub-wire harness connector using the terminal removal tool.

Figure 19.

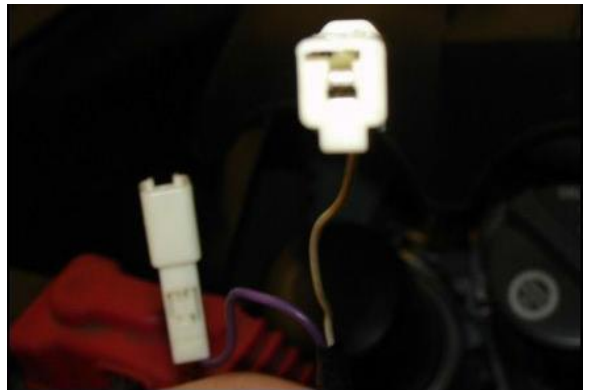

## Lack of A/C Performance at Idle in High Ambient Temperature

---

### Repair Procedure (continued)

15. Install the purple wire (that was removed from the EA1 connector in step 13) into the connector body that was removed from the sub-wire harness in step 14.

Figure 20.



16. Connect the connector in the sub-wire harness to the purple wire connector.

Figure 21.

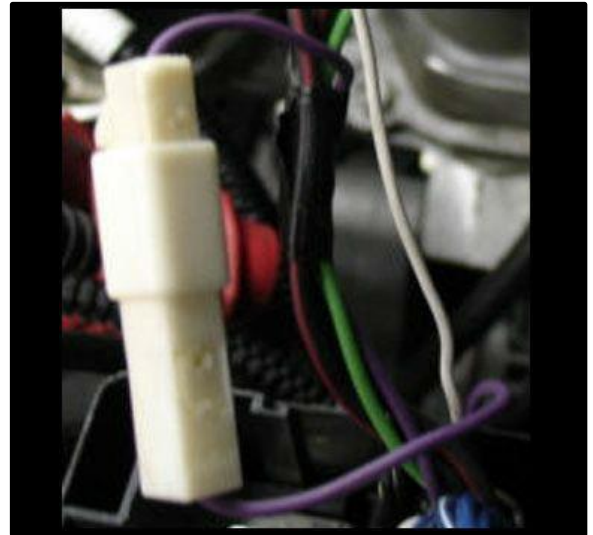

## Lack of A/C Performance at Idle in High Ambient Temperature

### Repair Procedure (continued)

17. Install the purple wire that was removed in step 14 from the sub-wire harness connector (purple wire) into the EA1 connector pin No. 3. Ensure that the pin lock is seated.

**Figure 22.**

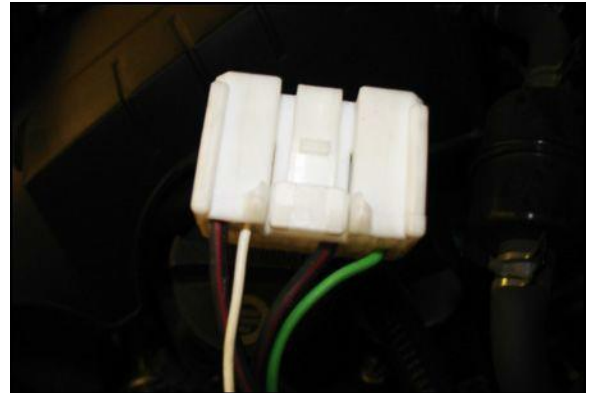

18. Route the harness into the relay block and ensure that the wire harness is NOT pinched.

**Figure 23.**



19. Plug the connectors back into the relay block. The sub-wire connector will sit in the relay block between the connectors.

**Figure 24.**

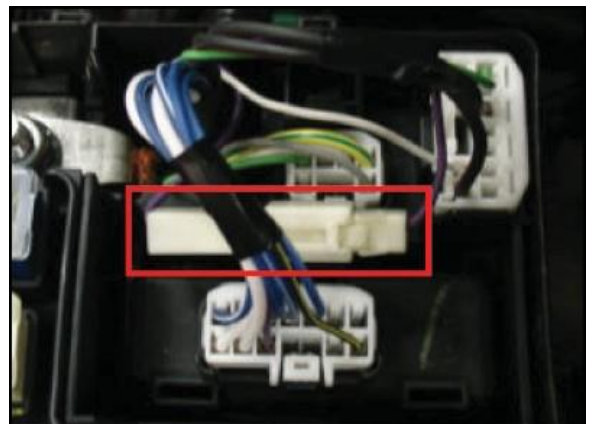

## Lack of A/C Performance at Idle in High Ambient Temperature

### Repair Procedure (continued)

20. Unscrew the nut from the stud bolt on the positive battery cable. Put the ring terminal from the sub-wire harness (white) onto the stud bolt. Tighten the nut.

**Torque: 9.8 – 15.7 N\*m**  
**(103 – 159 kgf\*cm, 7.5 – 11.5 ft\*lb)**

Figure 25.



21. Locate the bolt holes on the driver side inner fender. Attach the bracket included in the kit to the inner fender with the bolts included in the kit.

**Torque: 9.8 – 18.1 N\*m**  
**(100 – 185 kgf\*cm, 7.5 – 13ft\*lb)**

Figure 26.



22. Install the supplied notice label on the inside of the additional relay block relay cover.

Figure 27.



## Lack of A/C Performance at Idle in High Ambient Temperature

---

### Repair Procedure (continued)

23. Install the relay included in the kit into the CDS FAN location as indicated on the Notice label.

Figure 28.



24. Attach the relay block to the bracket installed in step 21.

Figure 29.



## Lack of A/C Performance at Idle in High Ambient Temperature

### Repair Procedure (continued)

25. Route the sub-wire harness as shown, between the relay block and the body.
26. Attach the sub-wire harness to the engine room main wire harness with a tie band and cut off the excess.

**Figure 30.**

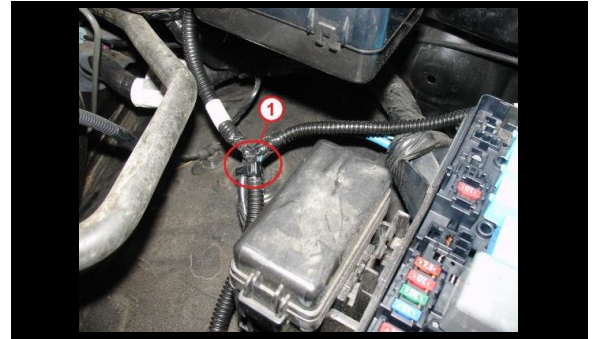

<b>1</b>	<b>Tie Band</b>
----------	-----------------

27. Secure the sub-wire harness to the relay block as shown with a tie band and cut off the excess.

**Figure 31.**



## Lack of A/C Performance at Idle in High Ambient Temperature

### Repair Procedure (continued)

28. Remove the ground terminal from the engine room main harness.
  - A. Attach the ring terminal from the sub-wire harness white wire.
  - B. Reinstall the ground terminal into the original position.

**Torque: 7 – 9.8 N\*m  
(71 – 100 kgf\*cm, 5 – 7.2 ft\*lbf)**

  - C. Attach the sub-wire harness to the engine harness with the tie bands as indicated and cut off the excess.

**Figure 32.**



<b>1</b>	<b>Tie Band</b>
----------	-----------------

29. Remove the radiator support shroud by disengaging the nine clips.

**Figure 33.**



30. Route the sub-wire harness along the radiator support. Secure the harness with tie bands and cut off the excess.

**Figure 34.**

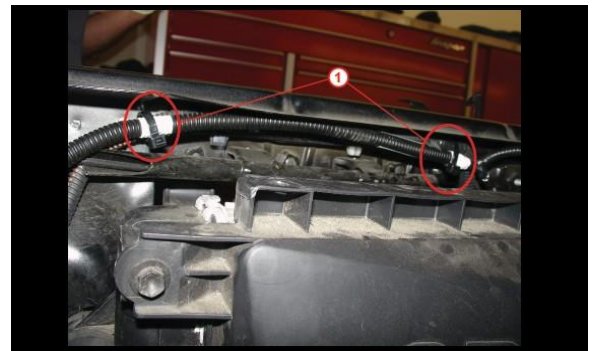

<b>1</b>	<b>Tie Band</b>
----------	-----------------



## Lack of A/C Performance at Idle in High Ambient Temperature

### Repair Procedure (continued)

31. Connect the sub-wire harness connector to the cooling fan added from the kit and attached the sub-wire harness with a tie band to the hood lock support brace and cut off the excess.

**Figure 35.**

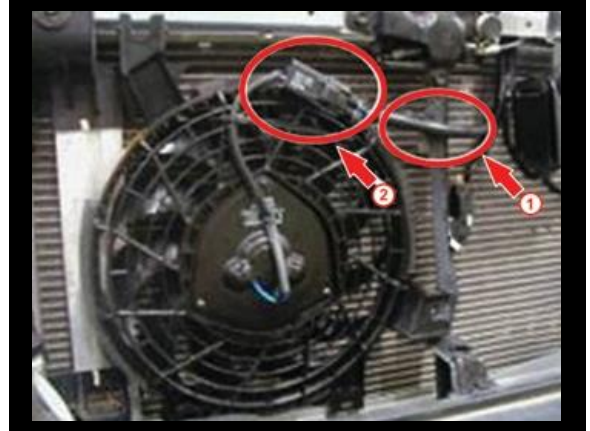

<b>1</b>	Tie Band
<b>2</b>	Connector

32. Attach the sub-wire harness as shown.

**Figure 36.**

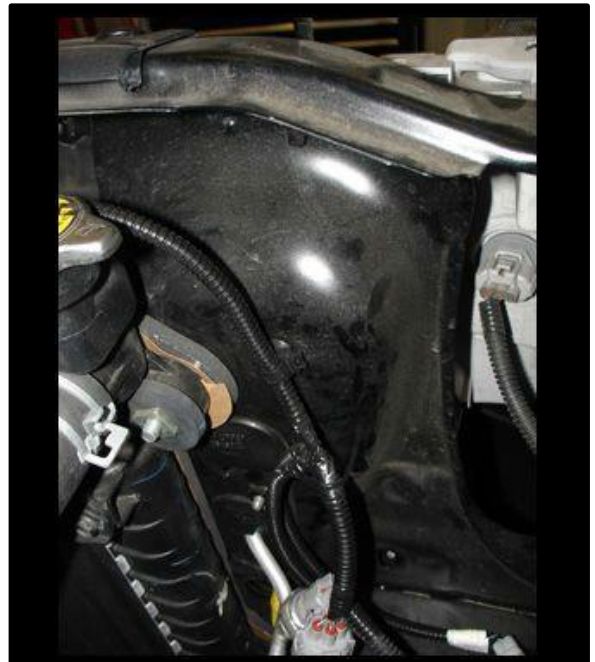

33. Remove the 2-pin pressure switch and replace it with the 4-pin switch included with the kit.

## Lack of A/C Performance at Idle in High Ambient Temperature

### Repair Procedure (continued)

34. Connect the vehicle 2-pin connector to the sub-wire harness 2-pin connector. Connect the sub-wire 4-pin connector to the 4-pin pressure switch installed in step 33.

**Figure 37.**



35. Attach the sub-wire harness to the leg of the bracket under the power steering reservoir tank with a tie band and cut off excess.

**Figure 38.**

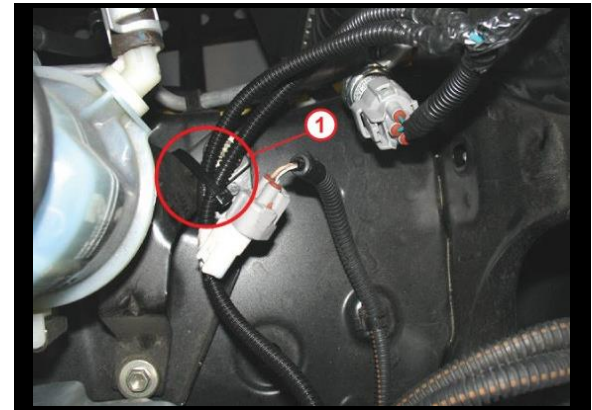

<b>1</b>	<b>Tie Band</b>
----------	-----------------

36. Attach the sub-wire harness to the engine wire harness in front of the windshield washer reservoir with a tie band and cut off the excess.

**Figure 39.**

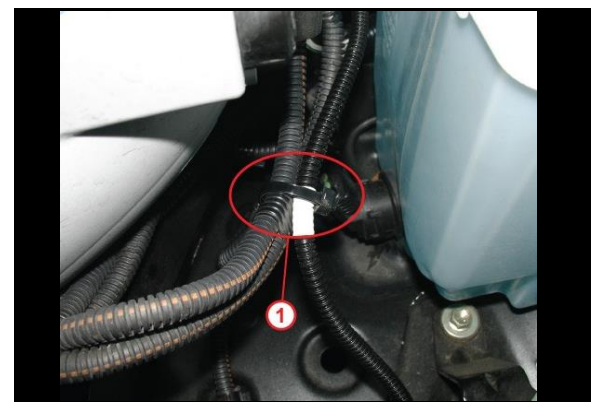

<b>1</b>	<b>Tie Band</b>
----------	-----------------

## Lack of A/C Performance at Idle in High Ambient Temperature

### Repair Procedure (continued)

37. Remove the windshield washer reservoir and attach the sub-wire harness ground terminal to the ground point behind the reservoir.

**Torque: 7 – 9.8 N\*m**

**(70 – 100 kgf\*cm, 5 – 7.2 ft\*lbf)**

Figure 40.



38. Reattach the windshield washer reservoir to the fender.
39. Confirm that the sub-wire harness is installed correctly.
40. Recharge the A/C system and inspect for any leaks.

Refer to the TIS, applicable model and model year Repair Manual:

- 2015 Tacoma:

*Vehicle Interior – Heating/Air Conditioning – [“Air Conditioning: Refrigerant: Replacement”](#)*

41. Remove the four bolts holding the radiator in place.

Figure 41.

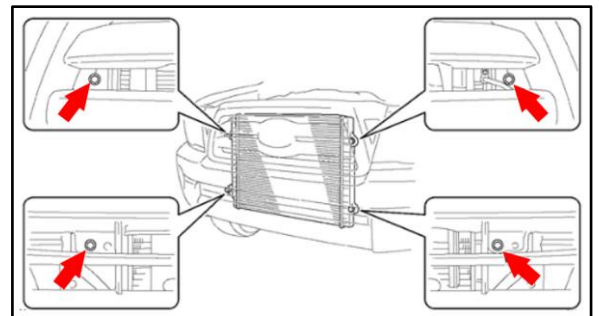

42. Lift up and push back on the radiator, releasing the hooks holding it in place.

Figure 42.



## Lack of A/C Performance at Idle in High Ambient Temperature

### Repair Procedure (continued)

43. Install the eight radiator core support body plugs and seals included in the kit.

**Figure 43.**

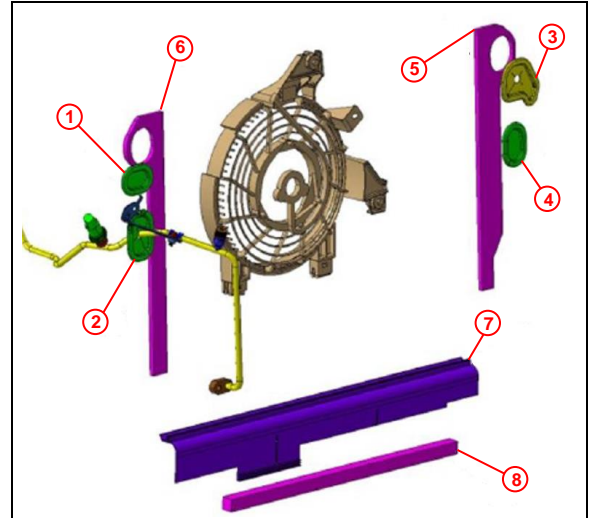

<b>1</b>	<b>Body Plug, Upper RH</b>
<b>2</b>	<b>Body Plug, Lower RH</b>
<b>3</b>	<b>Body Plug, Upper LH</b>
<b>4</b>	<b>Body Plug, Lower LH</b>
<b>5</b>	<b>Radiator Seal, LH</b>
<b>6</b>	<b>Radiator Seal, RH</b>
<b>7</b>	<b>Lower Radiator Seal</b>
<b>8</b>	<b>Skid Plate Seal</b>

## Lack of A/C Performance at Idle in High Ambient Temperature

### Repair Procedure (continued)

- A. Peel the adhesive backing off the LH and RH foam radiator seals included in the kit and install with the arrow pointing down. The adhesive side should be installed towards the radiator.

**NOTE**

Foam seals have markings on them distinguishing right from left and top from bottom.

**Figure 44.**

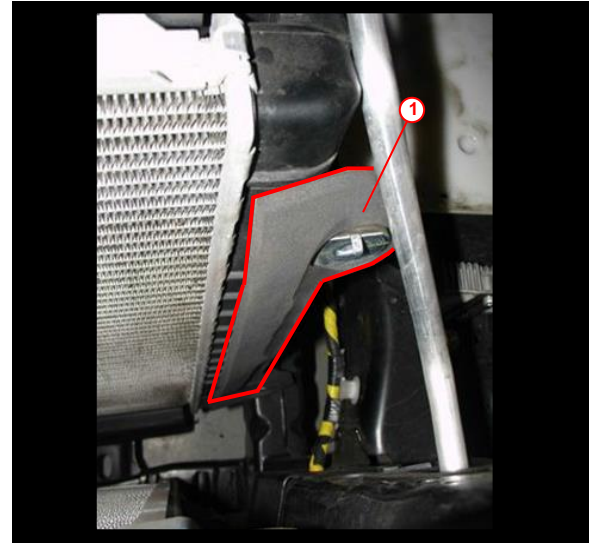

<b>1</b>	<b>Foam Seal</b>
----------	------------------

- B. Reinstall the four radiator support bolts.
- C. Install the NEW body plugs included in the kit in the indicated locations. Reference step 43 for location positions.

**Figure 45.**

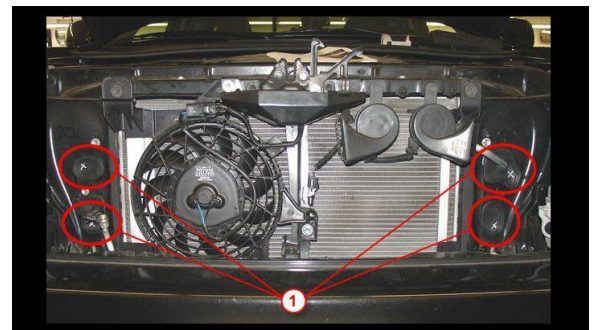

<b>1</b>	<b>Body Plug</b>
----------	------------------

## Lack of A/C Performance at Idle in High Ambient Temperature

### Repair Procedure (continued)

- D. Remove the No. 1 engine under the cover sub-assembly.

**Figure 46.**

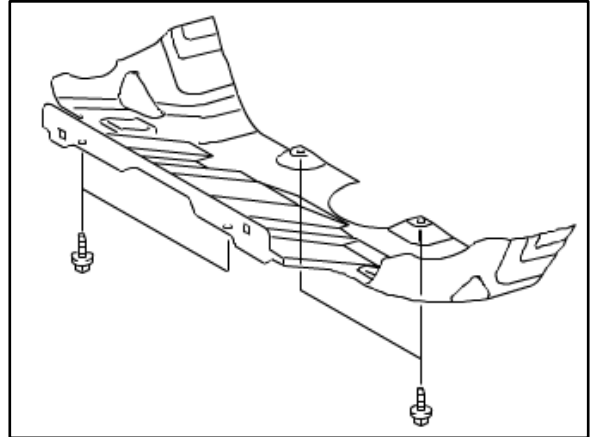

- E. Install the lower radiator seal as shown.

**Figure 47.**



- F. Install the skid plate seal included in the kit in the position as shown.

**Figure 48.**



- G. Reinstall the No. 1 engine under cover sub-assembly.

## Lack of A/C Performance at Idle in High Ambient Temperature

---

### Repair Procedure (continued)

44. Reinstall the radiator grille.
  
45. Reinstall the battery and ensure the sub-wire harness is NOT being pinched by the battery cable.  
**Torque: 5.4 N\*m (55 kgf\*cm, 48 in\*lbf)**
  
46. Verify installation and air conditioning operation.