

SERVICE ACTION

Reference number:	SA-01-1132V2	Issued: 22 February, 2019
Subject:	Door Glass Seal Push Out	
Model(s):	Vantage 19MY	
VIN range:	Refer to the separately published list of affected Vehicle Identification Numbers (VINs)	
Applicable to:	All Dealers	
Distribute to:	After Sales Manager Executive Manager Service Manager Sales Manager	Warranty Staff Technician(s) Parts Staff

Reason for Version 2 of this Service Action

The procedure to adjust the door glass has changed since Service Action SA-01-1132. The changes to this document have a black line against them in the left margin. Please destroy all copies of SA-01-1132 and replace them with Service Action SA-01-1132V2.

Reason for this Service Action

Aston Martin has identified a problem with the operation of the door glass in early Vantage 19MY vehicles. It is possible that the door glass can catch the door glass seal when the door glass is raised. This can then push the door glass seal off the door.

Do the workshop procedure that follows to correct this problem.

Workshop Procedure

This workshop procedure has the parts that follow:

- Part A – Test the door glass operation
- Part B – Adjust the Vertical Position of The Door Glass
- Part C – Adjust the Horizontal Position of The Door Glass

Part A – Test the door glass operation

1. Set the vehicle ignition to on.
2. Open the right-side door.
3. Fully lower the right-side door glass.

Note: *Steps 4 and 5 must be done at the same time.*

4. Use the 'one touch' function on the door window switch to lift the door glass (pull the door window switch up and then release it).
5. When the door glass is at its halfway position, push down on the top edge of the glass. This will operate the anti-trap feature.
6. Fully lower the door glass. The door glass will move to its lowest position in the door.
7. Do a visual inspection of the position of the door glass in relation to the door seal.
 - If the top of the door glass is lower than the door seal (refer to Figure 1), do parts B and C of this Bulletin for this door.
 - If the door glass touches the door seal, go to Step 8.



Figure 1

8. Move the door glass up.
 - If the door glass lifts the seal (refer to Figure 2), do parts B and C of this Service Bulletin for this door.
 - If the door glass moves up correctly, no more work is necessary for this door.



Figure 2

9. Do steps 2 thru 8 again for the left-side door glass.
10. Set the vehicle ignition to off.

Part B – Adjust the Vertical Position of The Door Glass

Notes: *The right door is shown in this procedure. The same steps apply to the left door.*

Part B is only necessary if the door glass catches below the door glass seals.

11. Remove the door speaker (refer to Workshop Manual Procedure 15.03.AB for the left side door or 15.03.BB for the right side door).

Note: *It is not necessary to disconnect the battery for this procedure. Power may be necessary to operate the door glass up and down.*

12. Release the water shedder panel from the adhesive that attaches it to the door panel (refer to Figure 3).

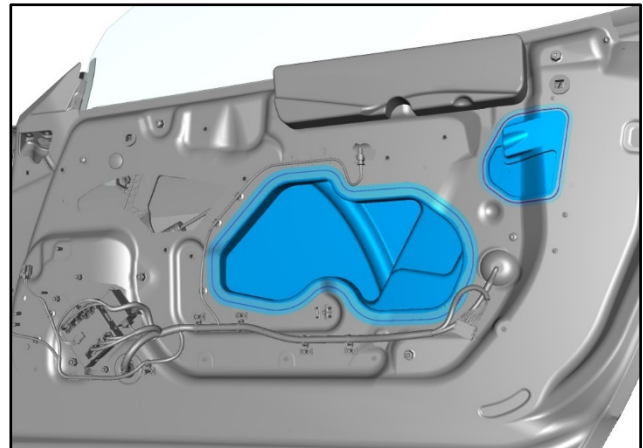

Figure 3

There are two methods that can be used to adjust the vertical position of the door glass. Only one method is necessary to adjust the vertical position of the door glass.

- Method 1 - Adjustment with a Flexible Socket Extension - (Steps 13 thru 15).
- Method 2 - Adjustment with Regulator Removed- (Steps 16 thru 29).

Use method 1 to adjust the door glass if you have access to a flexible socket extension. If you do not have a flexible socket extension, or access is limited, use method 2 to adjust the door glass.

Method 1 - Adjustment with a Flexible Socket Extension

13. Manually move the door glass up or down so that the front (1) and rear (2) regulator cursors are visible (refer to Figure 4).

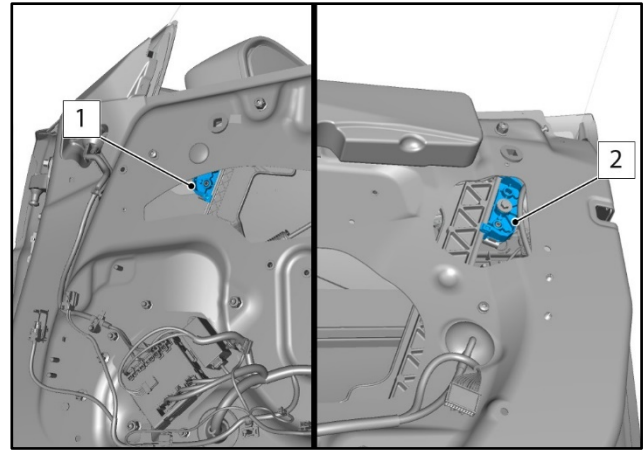
**Figure 4**

14. Fully tighten the vertical adjustment screw for the front regulator cursor (refer to Figure 5).

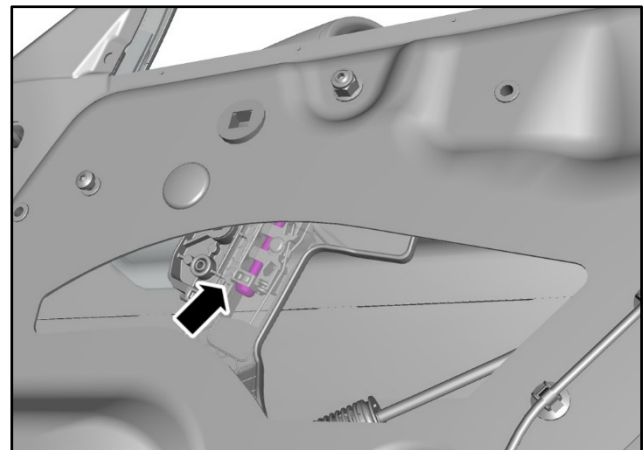
**Figure 5**

15. Fully tighten the vertical adjustment screw for the rear regulator cursor (refer to Figure 6).

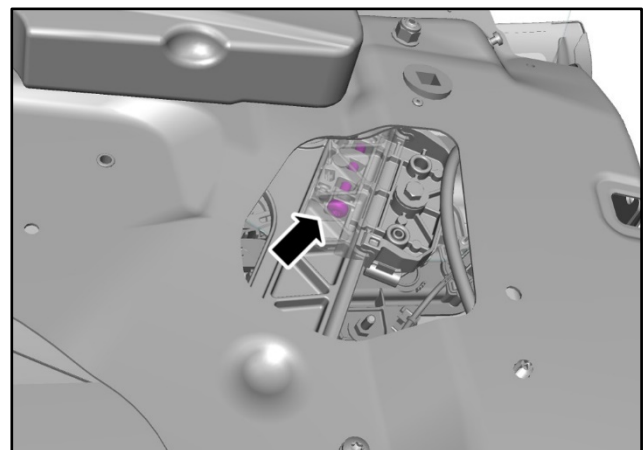
**Figure 6**

Method 2 - Adjustment with Regulator Removed

16. Remove the pin that attaches the inner waist seal to the door (refer to Figure 7).

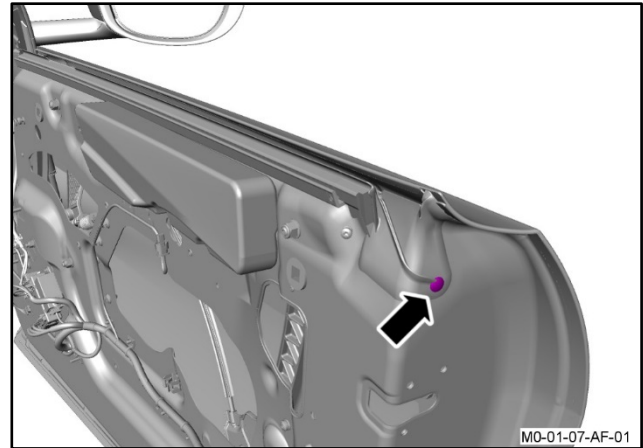
**Figure 7**

17. Release the end moulding for the inner waist seal from the door (refer to Figure 8).

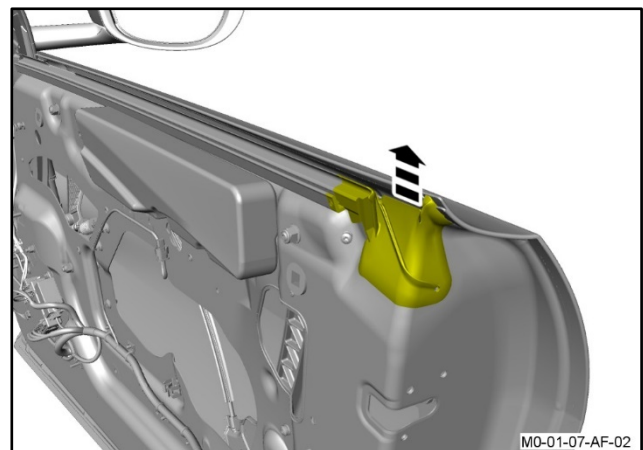
**Figure 8**

18. Release the inner waist seal from the door (refer to Figure 9).

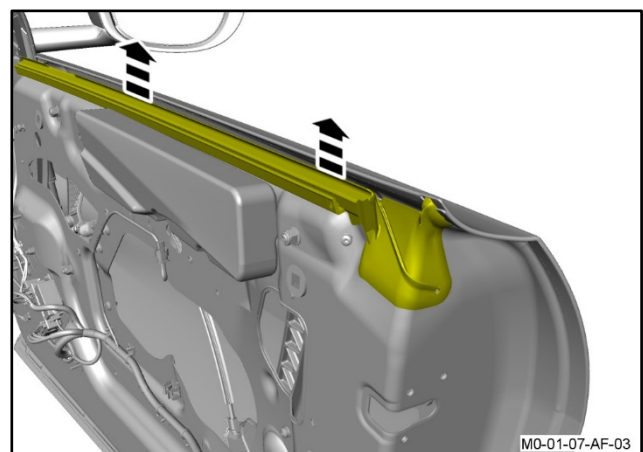
**Figure 9**

19. Remove the inner waist seal for the door (refer to Figure 10).

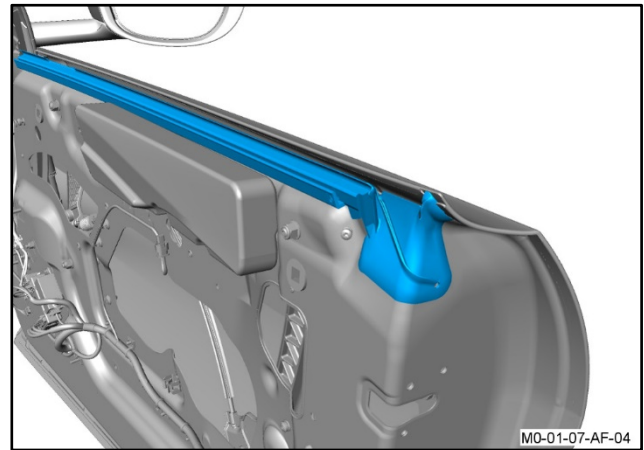

Figure 10

20. Remove the grommet (refer to Figure 11).

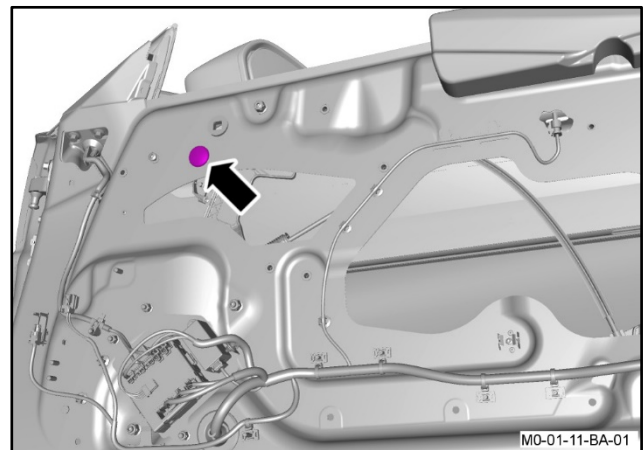

Figure 11

21. Remove the two bolts that attach the door glass to the regulator assembly (refer to Figure 12).

Note: Collect the two nut plates.

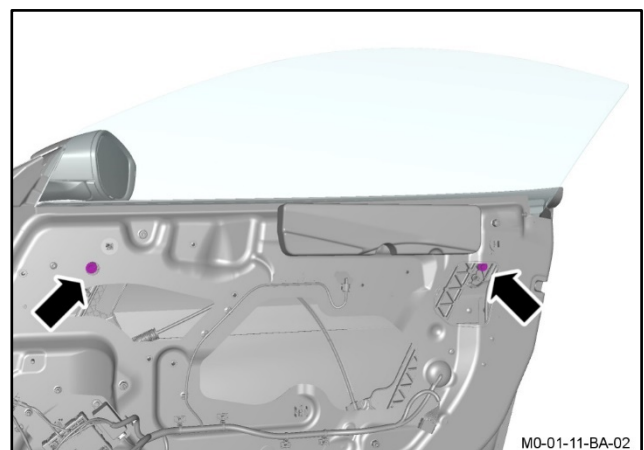

Figure 12

WARNING: PUT ON PROTECTIVE GLOVES AND EYE PROTECTION WHEN YOU HOLD THE DOOR GLASS. THE DOOR GLASS CAN BREAK AND CAUSE SERIOUS INJURY.

22. Carefully remove the door glass (refer to Figure 13).

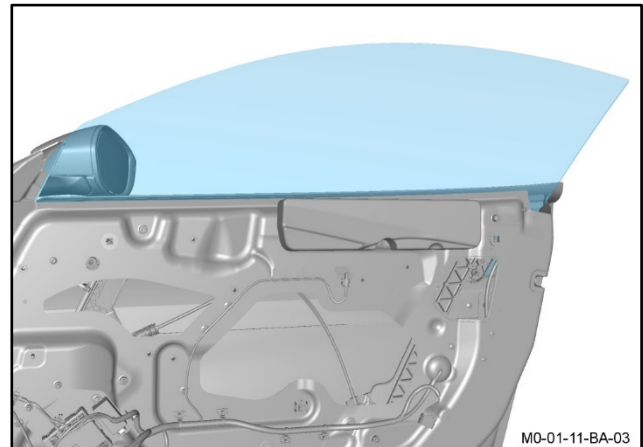

Figure 13

23. Disconnect the battery (refer to Workshop Manual procedure 14.01.CA).
24. Remove the five nuts that attach the regulator assembly to the door (refer to Figure 14).

Note: For installation, torque the nuts to 9 Nm.

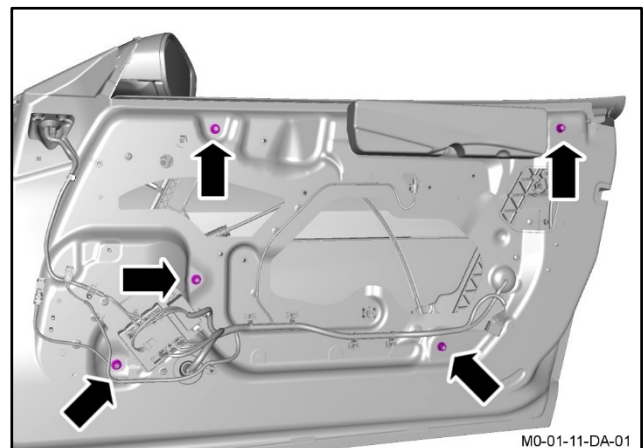

Figure 14

25. Disconnect the electrical connector for the regulator motor (refer to Figure 15).

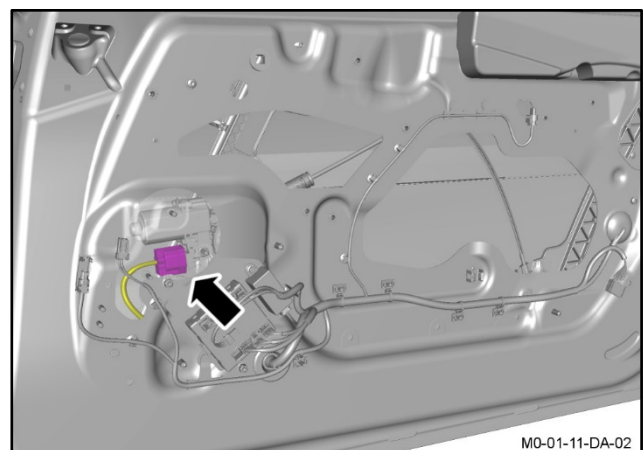

Figure 15

26. Remove the regulator assembly (refer to Figure 16).

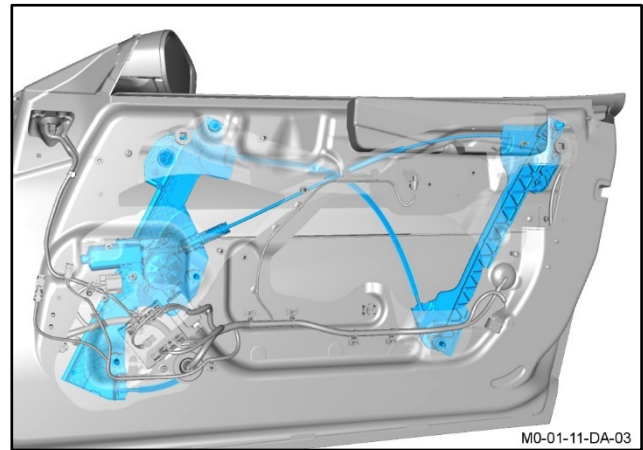

Figure 16

27. Fully tighten the vertical adjustment screw for the front regulator cursor (refer to Figure 17).

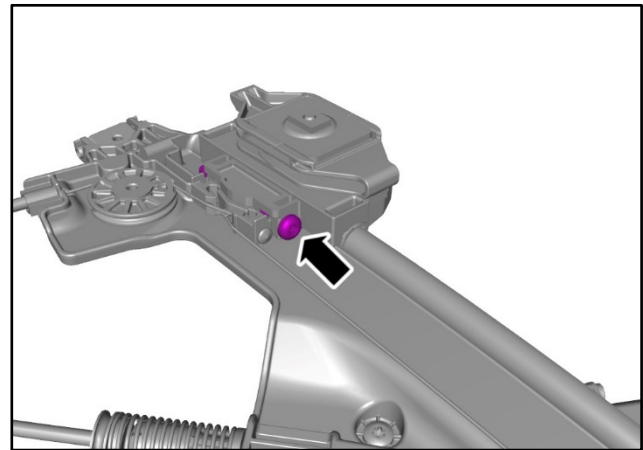

Figure 17

28. Fully tighten the vertical adjustment screw for the rear regulator cursor (refer to Figure 18).

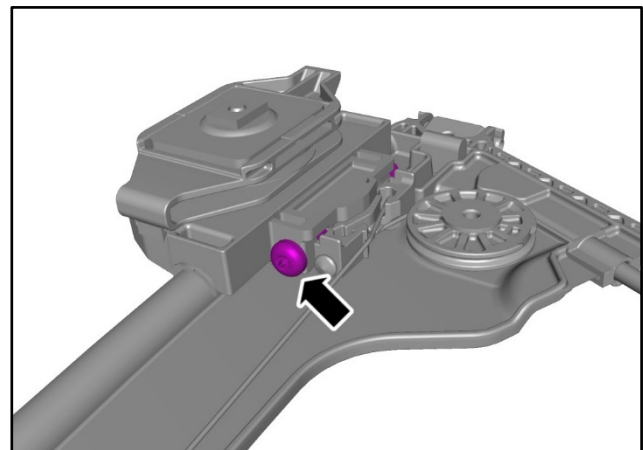
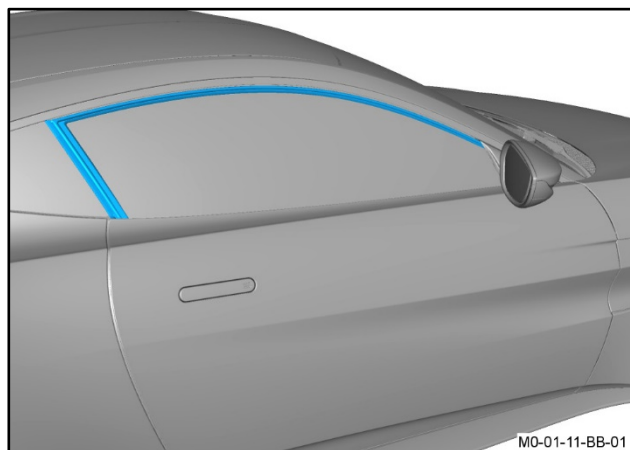

Figure 18

29. Do steps 16 thru 26 in the opposite sequence to install the window regulator and door glass.
30. Adjust the door glass as necessary.

Part C – Adjust the Horizontal Position of The Door Glass

31. Carefully make sure that the door glass aligns to the primary door weatherstrip correctly (refer to Figure 19).

**Figure 19**

32. If the door glass aligns to the primary door weatherstrip correctly, go to step 36.
33. If the door glass does not align to the primary door weatherstrip correctly, go to step 34.

CAUTION: MAKE SURE THAT SCREW (1) IS ADJUSTED BY HALF THE ADJUSTMENT OF SCREW (2) IN THE STEP THAT FOLLOWS (REFER TO FIGURE 20). IF YOU DO NOT, THE REGULATOR RAIL CAN BECOME TWISTED.

34. Adjust the door glass with the two lower regulator screws (2) until it aligns to the primary door weatherstrip correctly (refer to Figure 20).

Note: An adjustment of +/- 10 mm is possible with these regulator fixings.

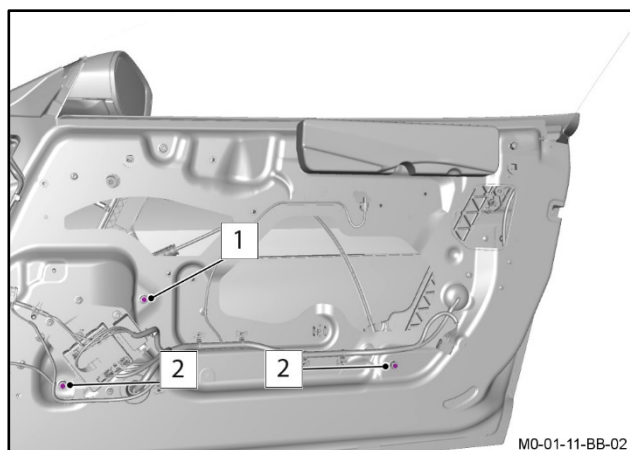
**Figure 20**

35. When the door glass is correctly aligned, torque the five nuts that attach the regulator to the door to 23 Nm (refer to Figure 21).

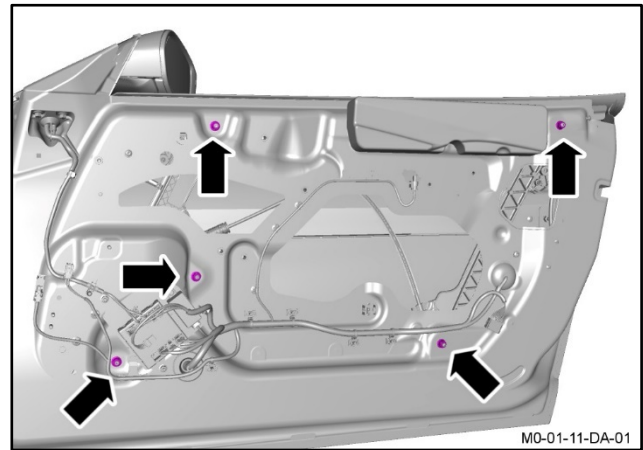

Figure 21

36. Carefully close the door.
37. Do a check of the alignment marks on the front and rear of the door glass (refer to Figure 22 and Figure 23).

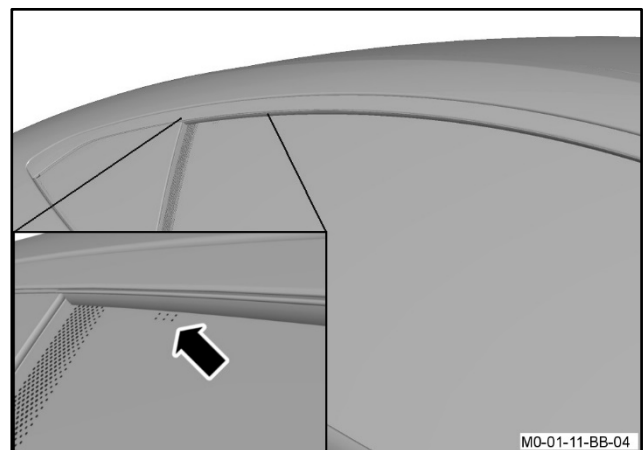

Figure 22

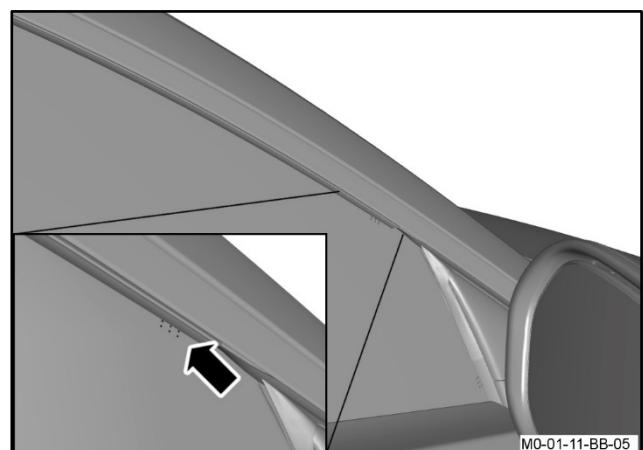

Figure 23

38. From outside the vehicle, the edge of the seal should be between the middle and lower row of dots for both sets of alignment marks.
- If adjustment is needed go to step 39.
 - If no adjustment is needed, go to step 46.

39. Lower the door glass so that the bolts for the door glass can be accessed (refer to Figure 24).

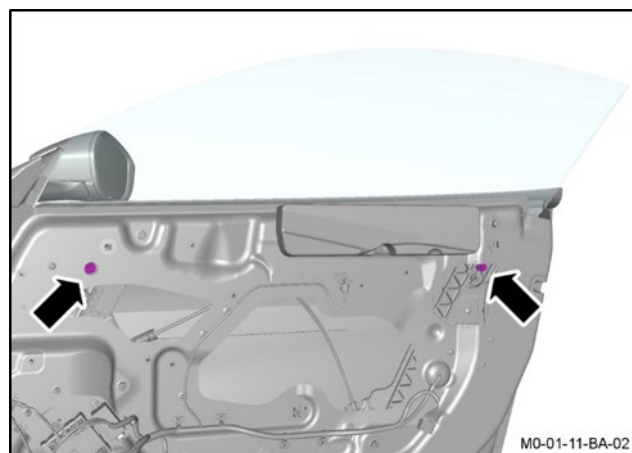

Figure 24

40. Loosen, but do not remove, the two bolts for the door glass.

WARNING: PUT ON PROTECTIVE GLOVES AND EYE PROTECTION WHEN YOU HOLD THE DOOR GLASS. THE DOOR GLASS CAN BREAK AND CAUSE SERIOUS INJURY.

41. Adjust the door glass as necessary.
42. Tighten, but do not fully torque, the two bolts for the door glass.
43. Lift the door glass to highest position.
44. Repeat steps 36 thru 43 until the door glass is correctly aligned.
45. Torque the two bolts for the door glass to 6 Nm.
46. Install the two water shedder panels (refer to Figure 25).

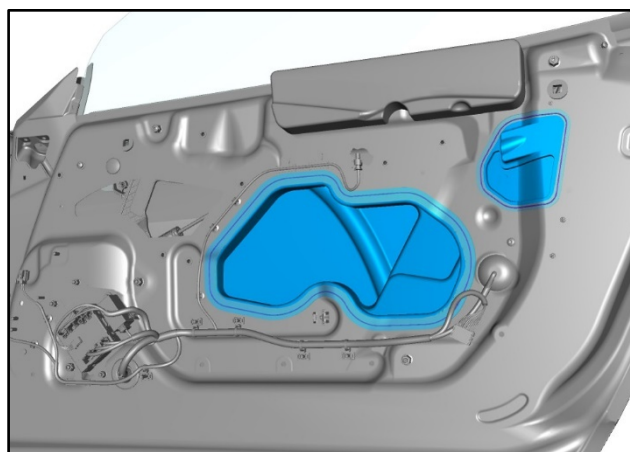

Figure 25

47. Install the door speaker (refer to Workshop Manual Procedure 15.03.AB for the left side door or 15.03.BB for the right side door).

Warranty Data**Procedure and Labour Time****Tier A**

Description	Inspection only	Inspection and repair
Test the left-side door glass operation and, if necessary, align the door glass.	0.2 hours	1.65

Tier B

Description	Inspection only	Inspection and repair
Test the right-side door glass operation and, if necessary, align the door glass.	0.2 hours	1.65

Tier C

Description	Inspection only	Inspection and repair
Test the door glass operation on both left and right sides. If necessary, align the door glass.	0.2 hours	3.30

Please Note:

When you have completed this Service Action, make sure that you make an entry in Section A of the Vehicle Owner's Guide to show that the procedure is completed.

If you have any questions related to this Service Action, please contact: Aston Martin Technical Services on: +44 (0) 1926 644720, email: askamtech@astonmartin.com, or contact your After Sales Manager.

The English version of this Service Action is written in Simplified Technical English to ASD-STE100™.