

January 2019  
FL783A-M  
NHTSA #18V-525  
Transport Canada #2018-418  
REVISED NOTICE

**Subject: Brake Caliper Mounting Bolts**

**Models Affected: Specific Freightliner 108SD, 114SD, 122SD, Business Class M2, Cascadia, Columbia, and Coronado vehicles manufactured January 2, 2017, through July 9, 2018, and equipped with air disc brakes.**

**General Information**

Daimler Trucks North America LLC (DTNA), on behalf of its Freightliner Trucks Division, has decided that a defect that relates to motor vehicle safety exists on the vehicles mentioned above.

There are approximately 4,909 vehicles involved in this campaign.

On certain vehicles, insufficiently torqued caliper mounting bolts may not provide adequate clamping force between the brake caliper and brake anchor plate, potentially resulting in reduced brake effectiveness, which could increase the risk of a crash.

Caliper mounting bolts will be inspected and replaced as needed.

**REVISION:** The required quantity per caliper for part# TDA 41X1801 is 2. The parts table has been corrected.

**Additional Repairs**

Dealers must complete all outstanding Recall and Field Service campaigns prior to the sale or delivery of a vehicle. A Dealer will be liable for any progressive damage that results from its failure to complete campaigns before sale or delivery of a vehicle.

Owners may be liable for any progressive damage that results from failure to complete campaigns within a reasonable time after receiving notification.

**Work Instructions**

Please refer to the attached work instructions. Prior to performing the campaign, check the vehicle for a completion sticker (Form WAR260).

**Replacement Parts**

Replacement parts are now available and can be obtained by ordering the part number(s) listed below from your facing Parts Distribution Center. **Letter groups include both front and rear axles and different caliper types, as noted for each group in the table below.**

**REVISION:** The required quantity per caliper for part# TDA 41X1801 is 2. The parts table has been corrected.

If our records show your dealership has ordered any vehicles involved in campaign number FL783, a list of the customers and vehicle identification numbers will be available in OWL. Please refer to this list when ordering parts for this recall.

**Table 1** - Replacement Parts for FL783A-M

Campaign Number	Part Number	Part Description	Qty. per Caliper
FL783A Front Axle (Only) Bendix Radial Caliper	23-13315-110	SCRW HX,SCKTHD,M16-2X110,12.9	6 ea
FL783B Front Axle (Only) Bendix Axial Caliper	N210931 020001	SCREW-CAP HEX M20X60 1.0 g P/O	6 ea
	23-09114-004	WASHER-HRDN,0.81X1.47X.177,ZN	
FL783C Front Axle (Only) Wabco Radial Caliper	23-13843-070	SCREW-CAP,SKT HD,M20X1.5X70	4 ea
FL783D Front & Rear Axle Bendix Radial Caliper	23-13315-110	SCRW HX,SCKTHD,M16-2X110,12.9	6 ea

January 2019  
FL783A-M  
NHTSA #18V-525  
Transport Canada #2018-418  
REVISED NOTICE

Campaign Number	Part Number	Part Description	Qty. per Caliper
FL783E Front Axle Bendix Radial Caliper	23-13315-110	SCRW HX,SCKTHD,M16-2X110,12.9	6 ea
FL783E Rear Axle Bendix Axial Caliper	N210931 020001	SCREW-CAP,HEX,M20X60,10.9,P/O	6 ea
	23-09114-004	WASHER-HRDN,0.81X1.47X.177,ZN	
FL783F Front Axle Bendix Axial Caliper	N210931 020001	SCREW-CAP,HEX,M20X60,10.9,P/O	6 ea
	23-09114-004	WASHER-HRDN,0.81X1.47X.177,ZN	
FL783F Rear Axle Bendix Radial Caliper	23-13315-110	SCRW HX,SCKTHD,M16-2X110,12.9	6 ea
FL783G Front & Rear Axle Bendix Axial Caliper	N210931 020001	SCREW-CAP,HEX,M20X60,10.9,P/O	6 ea
	23-09114-004	WASHER-HRDN,0.81X1.47X.177,ZN	
FL783H Front & Rear Axle Meritor Radial Caliper	TDA 41X1801	CAPSCREW M20	2 ea
FL783I Front Axle Meritor Radial Caliper	TDA 41X1801	CAPSCREW M20	2 ea
FL783I Rear Axle Meritor Axial Caliper	N210931 020001	SCREW-CAP,HEX,M20X60,10.9,P/O	6 ea
	23-09114-004	WASHER-HRDN,0.81X1.47X.177,ZN	
FL783J Front & Rear Axle Meritor Axial Caliper	N210931 020001	SCREW-CAP,HEX,M20X60,10.9,P/O	6 ea
	23-09114-004	WASHER-HRDN,0.81X1.47X.177,ZN	
FL783K Front & Rear Axle Wabco Radial Caliper	23-13843-070	SCREW-CAP,SKT HD,M20X1.5X70	4 ea
FL783L Front Axle Wabco Radial Caliper	23-13843-070	SCREW-CAP,SKT HD,M20X1.5X70	4 ea
FL783L Rear Axle Wabco Axial Caliper	N210931 020001	SCREW-CAP,HEX,M20X60,10.9,P/O	6 ea
	23-09114-004	WASHER-HRDN,0.81X1.47X.177,ZN	
FL783M Front & Rear Axle Wabco Axial Caliper	N210931 020001	SCREW-CAP,HEX,M20X60,10.9,P/O	6 ea
	23-09114-004	WASHER-HRDN,0.81X1.47X.177,ZN	
FL783A-M	TDA 3256B1354 or DSNCHA018005	TOOL-ADAPTER, WRENCH, ADB 225 or TOOL-ADAPTER, WRENCH	1 ea
FL783A-M	WAR260	BLANK COMPLETION STICKER	1 ea

Table 1. Cont. from page 1

## Removed Parts

U.S. and Canadian Dealers, please follow Warranty Failed Parts Tracking shipping instructions for the disposition of all removed parts. Export distributors, please destroy removed parts unless otherwise advised.

## Labor Allowance

Table 2 - Labor Allowance

Campaign Number	Procedure	Time Allowed (hours)	SRT Code	Corrective Action
FL783A-C	Inspect caliper bolts, Front axle only	1.0	996-R050F	06-Inspect Recall/Campaign
FL783C-M	Inspect caliper bolts, 2 axles	2.0	996-R050A	06-Inspect Recall/Campaign
FL783C-M	Inspect caliper bolts, second rear axle Claim this SRT once for each additional rear axle, up to 2 times)	1.1	996-R050B	06-Inspect Recall/Campaign
FL783A-C	Torque/Replace caliper bolts, Front axle only	1.0	996-R050G	12-Repair Recall/Campaign
FL783C-M	Torque/Replace caliper bolts 2 axles	2.0	996-R050D	12-Repair Recall/Campaign

January 2019  
FL783A-M  
NHTSA #18V-525  
Transport Canada #2018-418  
REVISED NOTICE

Campaign Number	Procedure	Time Allowed (hours)	SRT Code	Corrective Action
FL783C-M	Torque/Replace caliper bolts, second rear axle (Claim this SRT once for each additional rear axle, up to 2 times)	1.1	996-R050E	12-Repair Recall/Campaign
FL783A-M	Replace caliper bolts, 1 caliper (claim this SRT once for each caliper requiring new bolts, up to 8 times)	0.5	996-R050C	12-Repair Recall/Campaign

**Table 2**

**IMPORTANT:** When the Recall has been completed, locate the base completion label in the appropriate location on the vehicle, and attach the red completion sticker provided in the recall kit (Form WAR260). If the vehicle does not have a base completion label, clean a spot on the appropriate location of the vehicle and first attach the base completion label (Form WAR259). If a recall kit is not required or there is no completion sticker in the kit, write the recall number on a blank sticker and attach it to the base completion label.

## Claims for Credit

You will be reimbursed for your parts, labor, and handling (landed cost for Export Distributors) by submitting your claim through the Warranty system within 30 days of completing this campaign. Please reference the following information in OWL:

- Claim type is **Recall Campaign**.
- In the FTL Authorization field, enter the campaign number and appropriate condition code (e.g. **FL783-A, FL783-B, etc.**).
- In the Primary Failed Part Number field, enter **25-FL783-000**.
- In the Parts field, enter the appropriate kit or part number(s) as shown in the Replacement Parts Table.
- In the Labor field, first enter the appropriate SRT from the Labor Allowance Table. Administrative time will be included automatically as SRT 939-6010A for 0.3 hours. **Some SRT's are optional and if needed, must be added manually**
- The VMRS Component Code is **013-001-129** and the Cause Code is **A1 - Campaign**.
- **U.S. and Canada -- Reimbursement for Prior Repairs.** When a customer asks about reimbursement, please do the following:
  - Accept the documentation of the previous repair.
  - Make a brief check of the customer's paperwork to see if the repair may be eligible for reimbursement. (See the "Copy of Owner Letter" section of this bulletin for reimbursement guidelines.)
  - Submit an OWL Recall Pre-Approval Request for a decision.
  - Include the approved amount on your claim in the Other Charges section.
  - Attach the documentation to the pre-approval request.
  - If approved, submit a based on claim for the pre-approval.
  - Reimburse the customer the appropriate amount.

**IMPORTANT:** OWL must be viewed prior to performing the recall to ensure the vehicle is involved and the campaign has not been previously completed. Also, check for a completion sticker prior to beginning work.

U.S. and Canadian dealers, contact the Warranty Campaigns Department via Web inquiry at DTNACONNECT.com / WSC, or the Customer Assistance Center at (800) 385-4357, after normal business hours, if you have any questions or need additional information. Export distributors, submit a Web inquiry or contact your International Service Manager.

**January 2019  
FL783A-M  
NHTSA #18V-525  
Transport Canada #2018-418  
REVISED NOTICE**

U.S. and Canadian Dealers: To return excess kit inventory related to this campaign, U.S. dealers must submit a Parts Authorization Return (PAR) to the Memphis PDC. Canadian dealers must submit a PAR to their facing PDC. All kits must be in resalable condition. PAR requests must include the original purchase invoice number. Export Distributors: Excess inventory is not returnable.

The letter notifying U.S. and Canadian vehicle owners is included for your reference.

Please note that the National Traffic and Motor Vehicle Safety Act, as amended (Title 49, United States Code, Chapter 301), requires the owner's vehicle(s) be corrected within a reasonable time after parts are available to you. The Act states that failure to repair a vehicle within 60 days after tender for repair shall be prima facie evidence of an unreasonable time. However, circumstances of a particular situation may reduce the 60 day period. Failure to repair a vehicle within a reasonable time can result in either the obligation to (a) replace the vehicle with an identical or reasonably equivalent vehicle, without charge, or (b) refund the purchase price in full, less a reasonable allowance for depreciation. The Act further prohibits dealers from selling a vehicle unless all outstanding recalls are performed. Any lessor is required to send a copy of the recall notification to the lessee within 10 days. Any subsequent stage manufacturer is required to forward this notice to its distributors and retail outlets within five working days.

January 2019  
FL783A-M  
NHTSA #18V-525  
Transport Canada #2018-418  
REVISED NOTICE

## Copy of Notice to Owners

### Subject: Brake Caliper Mounting Bolts

**For the Notice to U.S. Customers:** This notice is sent to you in accordance with the National Traffic and Motor Vehicle Safety Act. **For the Notice to Canadian Customers:** This notice is sent to you in accordance with the Canadian Motor Vehicle Safety Act.

Daimler Trucks North America LLC (DTNA), on behalf of its Freightliner Trucks Division, has decided that a defect that relates to motor vehicle safety exists on specific Freightliner 108SD, 114SD, 122SD, Business Class M2, Cascadia, Columbia, and Coronado vehicles manufactured January 2, 2017, through July 9, 2018, and equipped with air disc brakes.

On certain vehicles, insufficiently torqued caliper mounting bolts may not provide adequate clamping force between the brake caliper and brake anchor plate, potentially resulting in reduced brake effectiveness, which could increase the risk of a crash.

Caliper mounting bolts will be inspected and replaced as needed.

Please contact an authorized Daimler Trucks North America dealer to arrange to have the Recall performed and to ensure that parts are available at the dealership. To locate an authorized dealer, search online at [www.Daimler-TrucksNorthAmerica.com](http://www.Daimler-TrucksNorthAmerica.com). On the menu tab, select "Contact," scroll down to "Find a Dealer," and select the appropriate brand. The Recall will take up to four hours, depending on the work needed, and will be performed at no charge to you.

You may be liable for any progressive damage that results from your failure to complete the Recall within a reasonable time after receiving notification.

If you do not own the vehicle that corresponds to the identification number(s) which appears on the Recall Notification, please return the notification to the Warranty Campaigns Department with any information you can furnish that will assist us in locating the present owner. If you have leased this vehicle, Federal law requires that you forward this notice to the lessee within 10 days. If you are a subsequent stage manufacturer, Federal law requires that you forward this notice to your distributors and retail outlets within five working days. If you have paid to have this recall condition corrected prior to this notice, you may be eligible to receive reimbursement. Please see the reverse side of this notice for details.

**For the Notice to U.S. Customers:** If you have questions about this Recall, please contact the Warranty Campaigns Department at (800) 547-0712, 7:00 a.m. to 4:00 p.m. Pacific Time, Monday through Friday, e-mail address [DTNA.Warranty.Campaigns@Daimler.com](mailto:DTNA.Warranty.Campaigns@Daimler.com), or the Customer Assistance Center at (800) 385-4357 after normal business hours. If you are not able to have the defect remedied without charge and within a reasonable time, you may wish to submit a complaint to the Administrator, National Highway Traffic Safety Administration, 1200 New Jersey Avenue, SE., Washington, DC 20590; or call the Vehicle Safety Hotline at (888) 327-4236 (TTY: 800-424-9153); or to <http://www.safercar.gov>. **For the Notice to Canadian Customers:** If you have questions about this Recall, please contact the Warranty Campaigns Department at (800) 547-0712, 7:00 a.m. to 4:00 p.m. Pacific Time, Monday through Friday, e-mail address [DTNA.Warranty.Campaigns@Daimler.com](mailto:DTNA.Warranty.Campaigns@Daimler.com), or the Customer Assistance Center at (800) 385-4357 after normal business hours.

We regret any inconvenience this action may cause but feel certain you understand our interest in motor vehicle safety.

WARRANTY CAMPAIGNS DEPARTMENT

Enclosure

January 2019  
FL783A-M  
NHTSA #18V-525  
Transport Canada #2018-418  
REVISED NOTICE

## **Reimbursement to Customers for Repairs Performed Prior to Recall**

If you have already **paid** to have this recall condition corrected you may be eligible to receive reimbursement.

Requests for reimbursement may include parts and labor. Reimbursement may be limited to the amount the repair would have cost if completed by an authorized Daimler Trucks North America LLC dealer. The following documentation must be presented to your dealer for consideration for reimbursement.

Please provide original or clear copies of all receipts, invoices, and repair orders that show:

- The name and address of the person who paid for the repair
- The Vehicle Identification Number (VIN) of the vehicle that was repaired
- What problem occurred, what repair was done, when the repair was done
- Who repaired the vehicle
- The total cost of the repair expense that is being claimed
- Proof of payment for the repair (such as the front and back of a cancelled check or a credit card receipt)

Reimbursement will be made by check from your Daimler Trucks North America LLC dealer.

Please speak with your Daimler Trucks North America LLC authorized dealer concerning this matter.

January 2019  
FL783A-M  
NHTSA #18V-525  
Transport Canada #2018-418  
REVISED NOTICE

## Work Instructions

### Subject: Caliper Mounting Bolts

**Models Affected: Specific Freightliner 108SD, 114SD, 122SD, Business Class M2, Cascadia, Columbia, and Coronado vehicles manufactured January 2, 2017, through July 9, 2018, and equipped with air disc brakes.**

### General Procedure

**IMPORTANT:** Vehicles may have both **axial and radial** mounted calipers. Please follow work instructions based on the type of calipers on the vehicle.

Vehicles in groups A-C require work on the front calipers only. Lift the front axle, remove the front wheels and work on the front calipers. Select the applicable SRT for front caliper work when submitting the claim.

1. Check the base label (Form WAR259) for a completion sticker for FL783 (Form WAR260) indicating this work has been done. The base label is usually located on the passenger-side door, about 12 inches (30 cm) below the door latch. If a sticker is present for FL783, no work is needed. If there is no sticker, proceed with the next step.
2. Park the vehicle on a level surface, shut down the engine, and set the parking brake. Chock the tires.

### **DANGER**

**When working on the vehicle, shut down the engine, set the parking brake, and chock the tires. Before working under the vehicle, always place jack stands under the frame rails to ensure the vehicle cannot drop. Failure to follow these steps could result in serious personal injury or death.**

3. Raise the vehicle and support it on jack stands.
4. Remove all of the wheel assemblies.

**NOTE: For Bendix axial caliper work instructions, go to page 8 and Bendix radial caliper instructions, page 10. For Meritor axial caliper work instructions, go to page 13 and Meritor radial caliper instructions, page 14. For Wabco axial caliper work instructions, go to page 16, and Wabco radial caliper instructions, page 17.**

January 2019  
FL783A-M  
NHTSA #18V-525  
Transport Canada #2018-418  
REVISED NOTICE

## Front and Rear Caliper/Carrier Assembly Inspection and Installation - Bendix Axial Mounted Calipers

1. Set a torque wrench to  $375 \pm 25$  lbf·ft ( $508 \pm 34$  N·m) and tighten the caliper mounting bolts. If they do not turn, go to step 7. If they turn, go to step 2. It may be necessary to use Meritor extension tool TDA 3256B1354 or DTNA tool DSNCHA018005 to access the bolts. If an extension tool is used, see [Table 3](#).

**Torque Compensation with Meritor Extension Tool TDA 3256B1354\***



09/28/2018

f580518

All torque settings are  $\pm 40$  lbf·ft ( $\pm 54$  N·m)

Angle View	Extension Angle (degrees)	Wrench Length [inches (cm)]	Target Torque [lbf·ft (N·m)]	Tool Setting [lbf·ft (N·m)]
<p>0° 11/28/2016 f422613</p>	0	43.5 (110.5)	400 (542)	334 (453)
<p>45° 11/28/2016 f422614</p>	45			364 (494)
<p>90° 11/28/2016 f422615</p>	90			400 (542)
<p>135° 11/28/2016 f422616</p>	135			444 (602)

\* Compensation is calculated for a 43.5 inch (110.5 cm) nominal torque wrench using Meritor extension tool TDA 3256B1354 at various angles.

**Table 3, Torque Compensation with Meritor Extension Tool TDA 3256B1354**

January 2019  
FL783A-M  
NHTSA #18V-525  
Transport Canada #2018-418  
REVISED NOTICE

2. Remove the retainer pin, cotter pin, and brake pad retainer. Inspect the brake pad hardware to ensure it is in good condition. If it is not, file a WSC ticket for instructions.
3. Remove the brake pads.
4. Remove caliper bolts.

**IMPORTANT:** The caliper/carrier assemblies are left and right handed. Ensure that the correct assembly is installed on the right side of the vehicle.

5. Align each caliper/carrier assembly with the rotor by pushing the caliper against the shelf on the torque plate, then install the caliper/carrier assembly using new caliper mounting bolts. See **Fig. 1**.

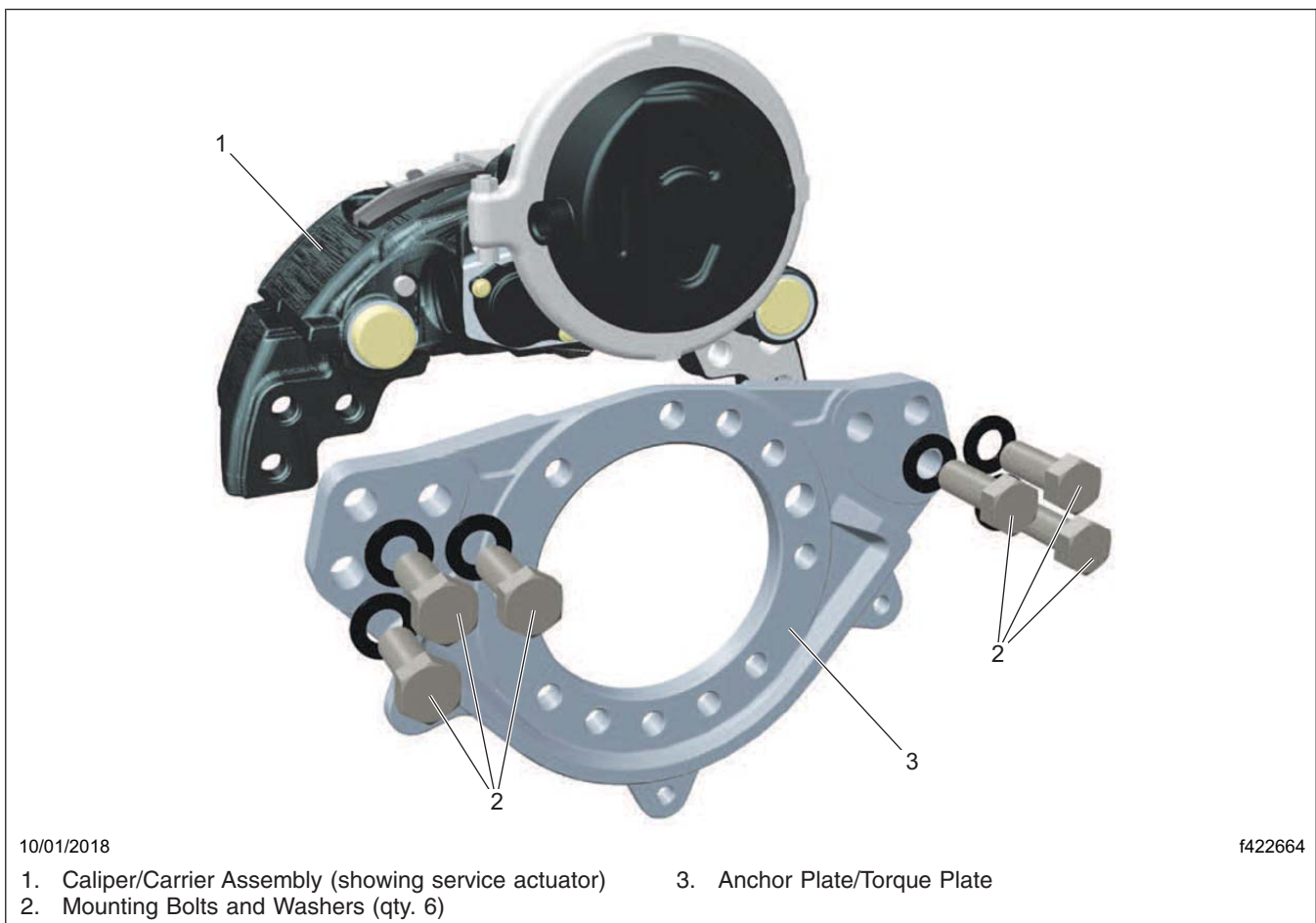

**Fig. 1, Bendix Axial Mounted Caliper**

6. Tighten the carrier mounting bolts in two steps as follows. See **Fig. 2**.



**Fig. 2, Tightening Pattern, Bendix Axial Caliper**

January 2019  
FL783A-M  
NHTSA #18V-525  
Transport Canada #2018-418  
REVISED NOTICE

- 6.1 Start on one side of the caliper and tighten all three bolts  $40\pm 20$  lbf·ft ( $54\pm 27$  N·m), beginning with the outer-most bolt and moving to the inner-most bolt. Then tighten the three bolts on the other side of the caliper  $40\pm 20$  lbf·ft ( $54\pm 27$  N·m), beginning with the inner-most bolt and moving to the outer-most bolt.
- 6.2 Repeat this process, increasing the torque value to  $375\pm 25$  lbf·ft ( $508\pm 34$  N·m).

---

## NOTICE

---

7. Install the brake pads. Provided it is good condition, use the brake pad hardware removed earlier.
8. Back off the adjuster nut three clicks.
9. Install the wheel assemblies.
10. Raise the vehicle, remove the jack stands, then lower the vehicle.
11. Charge the air system and check for leaks.

 **WARNING**

**Do not operate the vehicle until the brakes have been adjusted and checked for proper operation. To do so could result in inadequate or no braking ability, which could cause personal injury or death, and property damage.**

12. In a safe area, check for proper brake operation, as follows, before putting the vehicle in service.
  - 12.1 Apply and release the brakes several times to check for air leaks and proper operation.
  - 12.2 Perform six low-speed stops to ensure proper parts replacement and full vehicle control.
  - 12.3 Immediately after doing the above stops, check the rotor temperatures. Any rotors that are significantly cooler than others indicate a lack of braking effort on those wheels.
13. Clean a spot on the base label (Form WAR259). Write the recall number, FL783, on a completion sticker (Form WAR260), and attach it to the base label to indicate this recall has been completed.

## Front and Rear Caliper/Carrier Assembly Inspection and Installation - Bendix Radial Mounted Calipers

1. Set a torque wrench to  $225\pm 22.5$  lbf·ft ( $305\pm 31$  N·m) and tighten the caliper mounting bolts. If they do not turn, go to step 7. If they turn, go to step 2.
2. Remove the retainer pin, cotter pin, and brake pad retainer. Inspect the brake pad hardware to ensure it is in good condition. If it is not, file a WSC ticket for instructions.
3. Remove the brake pads.
4. Remove caliper bolts.

January 2019  
FL783A-M  
NHTSA #18V-525  
Transport Canada #2018-418  
REVISED NOTICE

IMPORTANT: The caliper/carrier assemblies are left and right handed. Ensure that the correct assembly (left or right) is installed on each side of the vehicle.

- Align each caliper/carrier assembly with the rotor by pushing the fixed pin side of the caliper against the shelf on the torque plate, then install the caliper/carrier assembly using new caliper mounting bolts. See [Fig. 3](#).

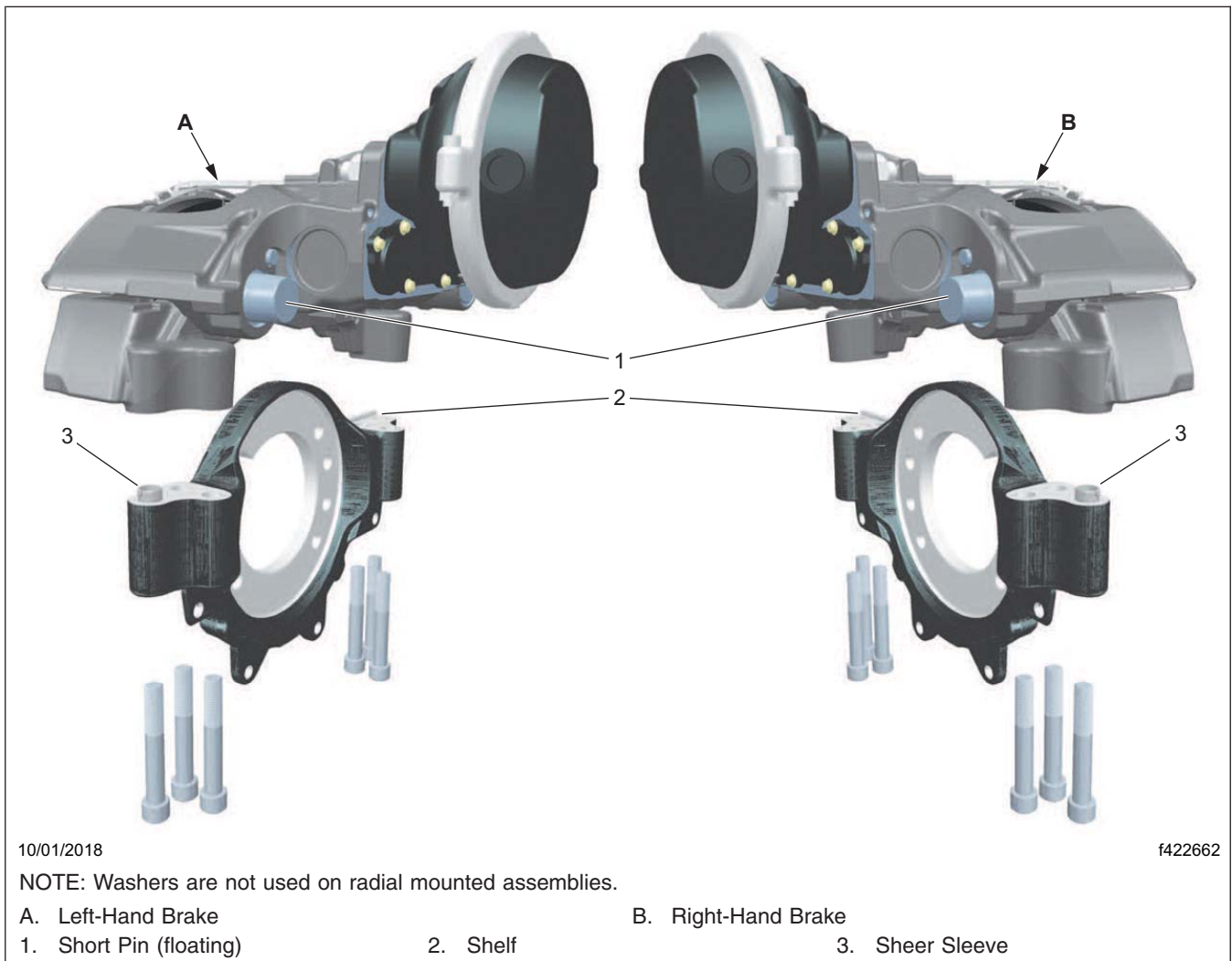
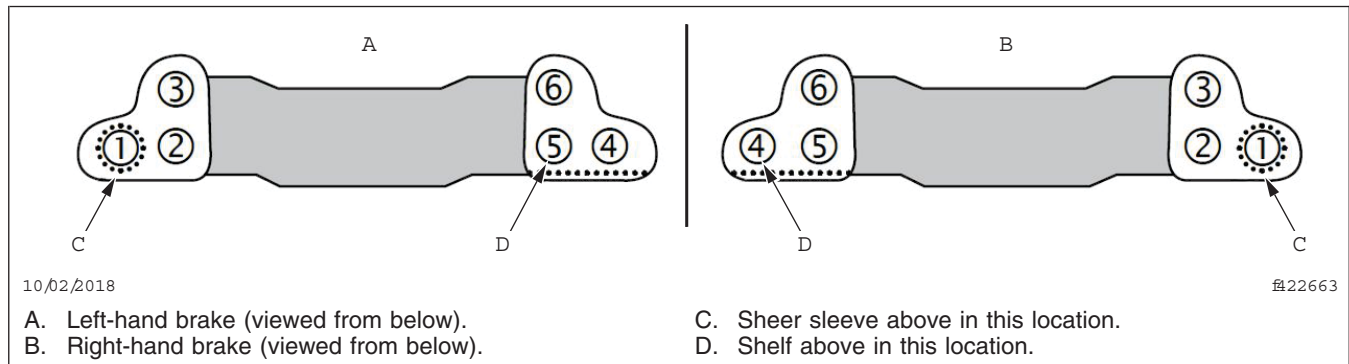

**Fig. 3, Bendix Radial Mounted Caliper**

January 2019  
FL783A-M  
NHTSA #18V-525  
Transport Canada #2018-418  
REVISED NOTICE

NOTE: The tightening pattern will always start on the short (floating) pin side, with the bolt that passes through the shear sleeve.

6. Tighten the carrier mounting bolts in two steps, using the pattern shown in Fig. 4.



**Fig. 4, Tightening Pattern, Bendix Radial Mounted Caliper**

- 6.1 Initially tighten all six bolts  $45 \pm 5$  lbf-ft ( $61 \pm 7$  N-m). Slide the caliper inboard and outboard, through the center of the chamber or brake. The caliper must have a minimum of 20 mm of travel. If the brake assembly does not move, or requires more than 40 pounds of force to move, the caliper has a binding issue. File a WSC ticket for instructions.
- 6.2 Perform a final tightening spec of  $225 \pm 22.5$  lbf-ft ( $305 \pm 31$  N-m). Slide the caliper inboard and outboard, through the center of the chamber or brake. The caliper must have a minimum of 20 mm of travel. If the brake assembly does not move, or requires more than 40 pounds of force to move, the caliper has a binding issue. File a WSC ticket for instructions.

## NOTICE

**Do not use a motor driven tool to tighten the manual brake adjuster nut, or use excessive force to tighten the nut. Doing so could damage the manual brake adjuster nut.**

7. Install the brake pads. Provided it is good condition, use the brake pad hardware removed earlier.
8. Back off the adjuster nut three clicks.
9. Install the wheel assemblies.
10. Raise the vehicle, remove the jack stands, then lower the vehicle.
11. Charge the air system and check for leaks.

## WARNING

**Do not operate the vehicle until the brakes have been adjusted and checked for proper operation. To do so could result in inadequate or no braking ability, which could cause personal injury or death, and property damage.**

12. In a safe area, check for proper brake operation, as follows, before putting the vehicle in service.
  - 12.1 Apply and release the brakes several times to check for air leaks and proper operation.
  - 12.2 Perform six low-speed stops to ensure proper parts replacement and full vehicle control.
  - 12.3 Immediately after doing the above stops, check the rotor temperatures. Any rotors that are significantly cooler than others indicate a lack of braking effort on those wheels.
13. Clean a spot on the base label (Form WAR259). Write the recall number, FL783, on a completion sticker (Form WAR260), and attach it to the base label to indicate this recall has been completed.

January 2019  
FL783A-M  
NHTSA #18V-525  
Transport Canada #2018-418  
REVISED NOTICE

## Front and Rear Caliper/Carrier Assembly Inspection and Installation - Meritor Axial Mounted Calipers

1. Set a torque wrench to  $400\pm 50$  lbf-ft ( $542\pm 68$  N-m) and tighten the caliper mounting bolts. If they do not turn go to step 7. If they turn, go to step 2. It may be necessary to use Meritor extension tool TDA 3256B1354 or DTNA tool DSNCHA018005 to access the bolts. If an extension tool is used, see [Table 3](#).
2. Remove the retainer pin, cotter pin, and brake pad retainer. Inspect the brake pad hardware to ensure it is in good condition. If it is not, file a WSC ticket for instructions.
3. Remove the brake pads.
4. Remove caliper bolts.

**IMPORTANT:** The caliper/carrier assemblies are left and right handed. Ensure that the correct assembly is installed on the right side of the vehicle.

**NOTE:** The Meritor axial mounted caliper is similar to the Bendix axial mounted caliper shown in [Fig. 1](#).

5. Align each caliper/carrier assembly with the rotor by pushing the caliper against the shelf on the torque plate, then install the caliper/carrier assembly using new caliper mounting bolts.
6. Tighten the carrier mounting bolts in two steps as follows.
  - 6.1 Start on one side of the caliper and tighten all of the bolts  $45\pm 5$  lbf-ft ( $61\pm 7$  N-m). Then tighten the bolts on the other side of the caliper  $45\pm 5$  lbf-ft ( $61\pm 7$  N-m). See [Fig. 2](#).
  - 6.2 Repeat this process, increasing the torque value to  $400\pm 50$  lbf-ft ( $542\pm 68$  N-m).

---

### NOTICE

---

**Do not use a motor driven tool to tighten the manual brake adjuster nut, or use excessive force to tighten the nut. Doing so could damage the manual brake adjuster nut.**

7. Install the brake pads. Provided it is good condition, use the brake pad hardware removed earlier.
8. Back off the adjuster nut three clicks.
9. Install the wheel assemblies.
10. Raise the vehicle, remove the jack stands, then lower the vehicle.
11. Charge the air system and check for leaks.

 **WARNING**

**Do not operate the vehicle until the brakes have been adjusted and checked for proper operation. To do so could result in inadequate or no braking ability, which could cause personal injury or death, and property damage.**

12. In a safe area, check for proper brake operation, as follows, before putting the vehicle in service.
  - 12.1 Apply and release the brakes several times to check for air leaks and proper operation.
  - 12.2 Perform six low-speed stops to ensure proper parts replacement and full vehicle control.
  - 12.3 Immediately after doing the above stops, check the rotor temperatures. Any rotors that are significantly cooler than others indicate a lack of braking effort on those wheels.
13. Clean a spot on the base label (Form WAR259). Write the recall number, FL783, on a completion sticker (Form WAR260), and attach it to the base label to indicate this recall has been completed.

January 2019  
FL783A-M  
NHTSA #18V-525  
Transport Canada #2018-418  
REVISED NOTICE

## Front and Rear Caliper/Carrier Assembly Inspection and Installation - Meritor Radial Mounted Calipers

1. Set a torque wrench to  $400\pm 50$  lbf-ft ( $542\pm 68$  N-m) and tighten the caliper mounting bolts. If they do not turn, go to step 7. If they turn, go to step 2.
2. Remove the retainer pin, cotter pin, and brake pad retainer. Inspect the brake pad hardware to ensure it is in good condition. If it is not, file a WSC ticket for instructions.
3. Remove the brake pads.
4. Remove caliper bolts.

**IMPORTANT:** The caliper/carrier assemblies are left and right handed. Ensure that the correct assembly (left or right) is installed on each side of the vehicle.

5. Align each caliper/carrier assembly with the rotor by pushing the fixed pin side of the caliper against the shelf on the torque plate, then install the caliper/carrier assembly using new caliper mounting bolts. See [Fig. 5](#) and [Fig. 6](#).

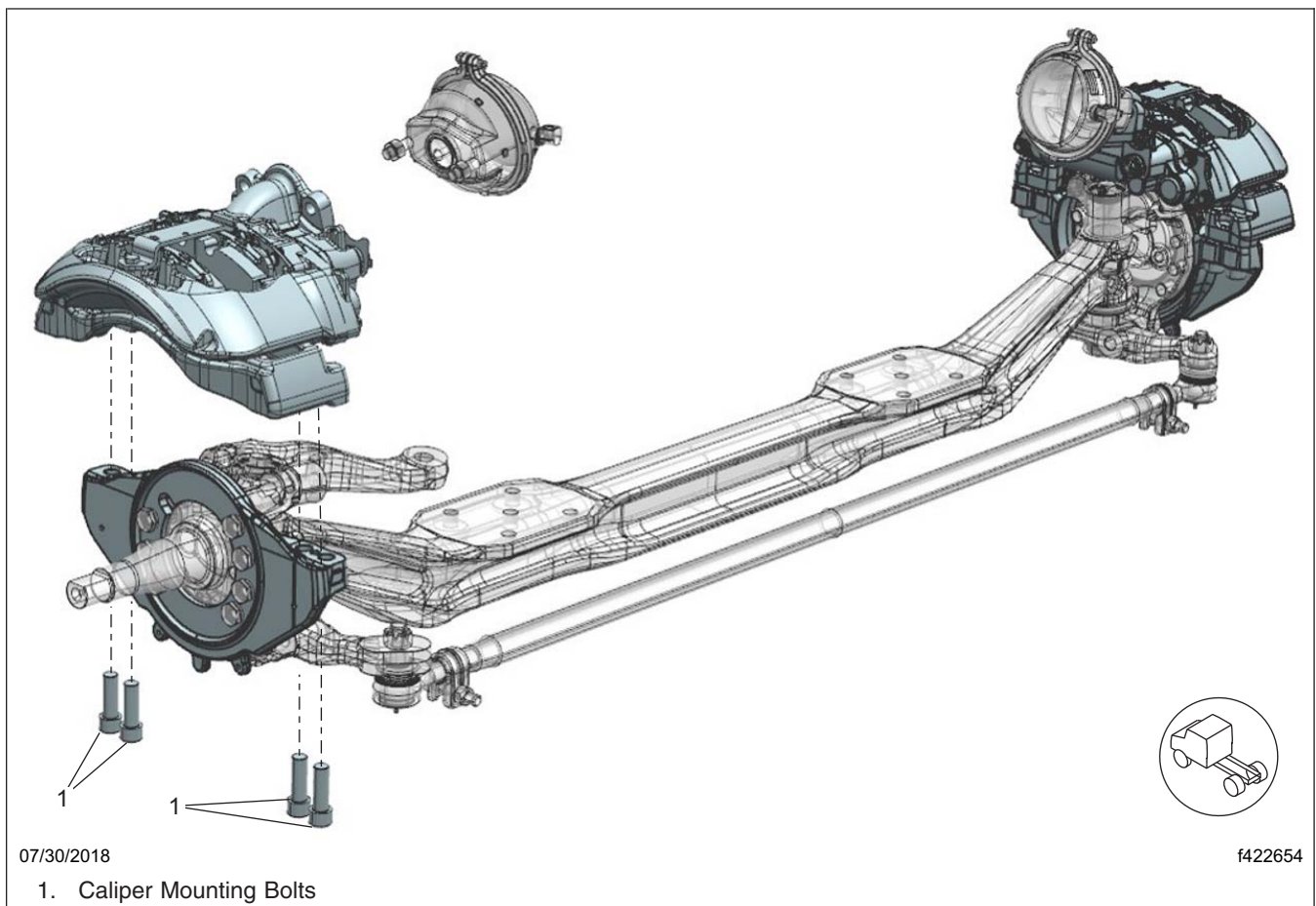
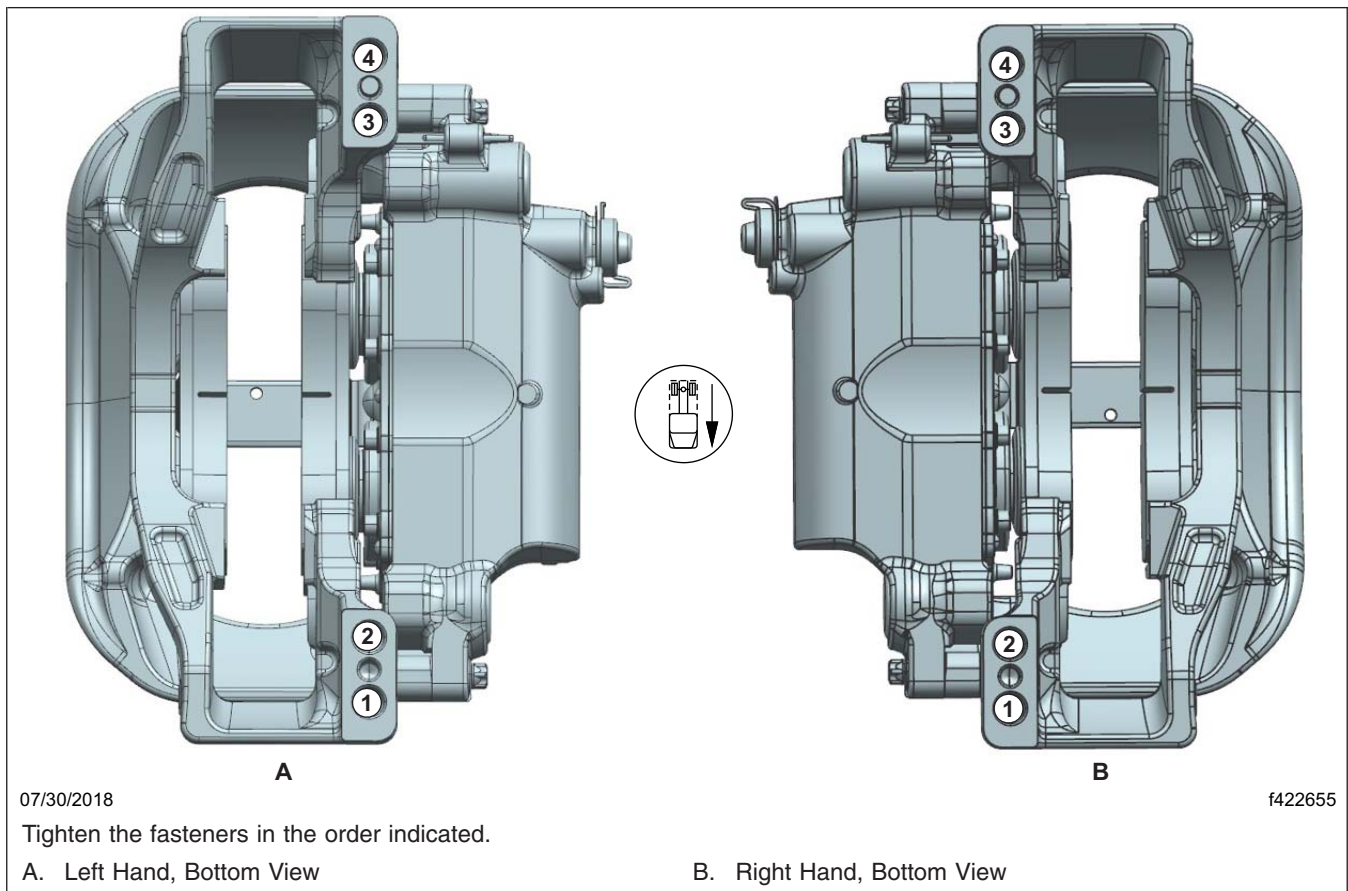

**Fig. 5, Meritor Radial Mounted Caliper**

January 2019  
FL783A-M  
NHTSA #18V-525  
Transport Canada #2018-418  
REVISED NOTICE

NOTE: The tightening pattern will always start on the short (floating) pin side, with the bolt that passes through the shear sleeve.

6. Tighten the carrier mounting bolts in two steps, using the pattern shown in **Fig. 6**.
  - 6.1 Initially tighten all bolts  $45\pm 5$  lbf-ft ( $61\pm 7$  N-m). Slide the caliper inboard and outboard, through the center of the chamber or brake. The caliper must have a minimum of 20 mm of travel. If the brake assembly does not move, or requires more than 40 pounds of force to move, the caliper has a binding issue. File a WSC ticket for instructions.
  - 6.2 Perform a final tightening spec of  $400\pm 50$  lbf-ft ( $542\pm 68$  N-m). Slide the caliper inboard and outboard, through the center of the chamber or brake. The caliper must have a minimum of 20 mm of travel. If the brake assembly does not move, or requires more than 40 pounds of force to move, the caliper has a binding issue. File a WSC ticket for instructions.



**Fig. 6, Tightening Pattern, Meritor Caliper**

## NOTICE

**Do not use a motor driven tool to tighten the manual brake adjuster nut, or use excessive force to tighten the nut. Doing so could damage the manual brake adjuster nut.**

7. Install the brake pads. Provided it is good condition, use the brake pad hardware removed earlier.
8. Back off the adjuster nut three clicks.

January 2019  
FL783A-M  
NHTSA #18V-525  
Transport Canada #2018-418  
REVISED NOTICE

9. Install the wheel assemblies.
10. Raise the vehicle, remove the jack stands, then lower the vehicle.
11. Charge the air system and check for leaks.

## WARNING

**Do not operate the vehicle until the brakes have been adjusted and checked for proper operation. To do so could result in inadequate or no braking ability, which could cause personal injury or death, and property damage.**

12. In a safe area, check for proper brake operation, as follows, before putting the vehicle in service.
  - 12.1 Apply and release the brakes several times to check for air leaks and proper operation.
  - 12.2 Perform six low-speed stops to ensure proper parts replacement and full vehicle control.
  - 12.3 Immediately after doing the above stops, check the rotor temperatures. Any rotors that are significantly cooler than others indicate a lack of braking effort on those wheels.
13. Clean a spot on the base label (Form WAR259). Write the recall number, FL783, on a completion sticker (Form WAR260), and attach it to the base label to indicate this recall has been completed.

## Front and Rear Caliper/Carrier Assembly Inspection and Installation - Wabco Maxxus Axial Mounted Calipers

1. Set a torque wrench to  $375\pm 25$  lbf-ft ( $508\pm 34$  N·m) and tighten the caliper mounting bolts. If they do not turn, go to step 7. If they turn, go to step 2. It may be necessary to use Meritor extension tool TDA 3256B1354 or DTNA tool DSNCHA018005 to access the bolts. If an extension tool is used, see [Table 3](#).
2. Remove the retainer pin, cotter pin, and brake pad retainer. Inspect the brake pad hardware to ensure it is in good condition. If it is not, file a WSC ticket for instructions.
3. Remove the brake pads.
4. Remove caliper bolts.

**IMPORTANT:** The caliper/carrier assemblies are left and right handed. Ensure that the correct assembly is installed on the right side of the vehicle.

**NOTE:** The Wabco axial mounted caliper is similar to the Bendix axial mounted caliper shown in [Fig. 1](#).

5. Align each caliper/carrier assembly with the rotor by pushing the caliper against the shelf on the torque plate, then install the caliper/carrier assembly using new caliper mounting bolts.
6. Tighten the carrier mounting bolts in two steps as follows.
  - 6.1 Start on one side of the caliper and tighten all of the bolts  $45\pm 5$  lbf-ft ( $61\pm 7$  N·m). Then tighten the bolts on the other side of the caliper  $45\pm 5$  lbf-ft ( $61\pm 7$  N·m). See [Fig. 2](#).
  - 6.2 Repeat this process, increasing the torque value to  $375\pm 25$  lbf-ft ( $508\pm 34$  N·m).

## NOTICE

**Do not use a motor driven tool to tighten the manual brake adjuster nut, or use excessive force to tighten the nut. Doing so could damage the manual brake adjuster nut.**

7. Install the brake pads. Provided it is good condition, use the brake pad hardware removed earlier.
8. Back off the adjuster nut three clicks.
9. Install the wheel assemblies.

January 2019  
FL783A-M  
NHTSA #18V-525  
Transport Canada #2018-418  
REVISED NOTICE

10. Raise the vehicle, remove the jack stands, then lower the vehicle.
11. Charge the air system and check for leaks.

 **WARNING**

**Do not operate the vehicle until the brakes have been adjusted and checked for proper operation. To do so could result in inadequate or no braking ability, which could cause personal injury or death, and property damage.**

12. In a safe area, check for proper brake operation, as follows, before putting the vehicle in service.
  - 12.1 Apply and release the brakes several times to check for air leaks and proper operation.
  - 12.2 Perform six low-speed stops to ensure proper parts replacement and full vehicle control.
  - 12.3 Immediately after doing the above stops, check the rotor temperatures. Any rotors that are significantly cooler than others indicate a lack of braking effort on those wheels.
13. Clean a spot on the base label (Form WAR259). Write the recall number, FL783, on a completion sticker (Form WAR260), and attach it to the base label to indicate this recall has been completed.

## Front and Rear Caliper/Carrier Assembly Inspection and Installation - Wabco Maxxus Radial Mounted Calipers

1. Set a torque wrench to  $295 \pm 22$  lbf·ft ( $400 \pm 30$  N·m) and tighten the caliper mounting bolts. If they do not turn, go to step 7. If they turn, go to step 2.
2. Remove the retainer pin, cotter pin, and brake pad retainer. Inspect the brake pad hardware to ensure it is in good condition. If it is not, file a WSC ticket for instructions.
3. Remove the brake pads.
4. Remove caliper bolts.

January 2019  
FL783A-M  
NHTSA #18V-525  
Transport Canada #2018-418  
REVISED NOTICE

IMPORTANT: The caliper/carrier assemblies are left and right handed. Ensure that the correct assembly (left or right) is installed on each side of the vehicle.

5. Align each caliper/carrier assembly with the rotor by pushing the fixed pin side of the caliper against the shelf on the torque plate, then install the caliper/carrier assembly using new caliper mounting bolts. See [Fig. 7](#) and [Fig. 8](#).

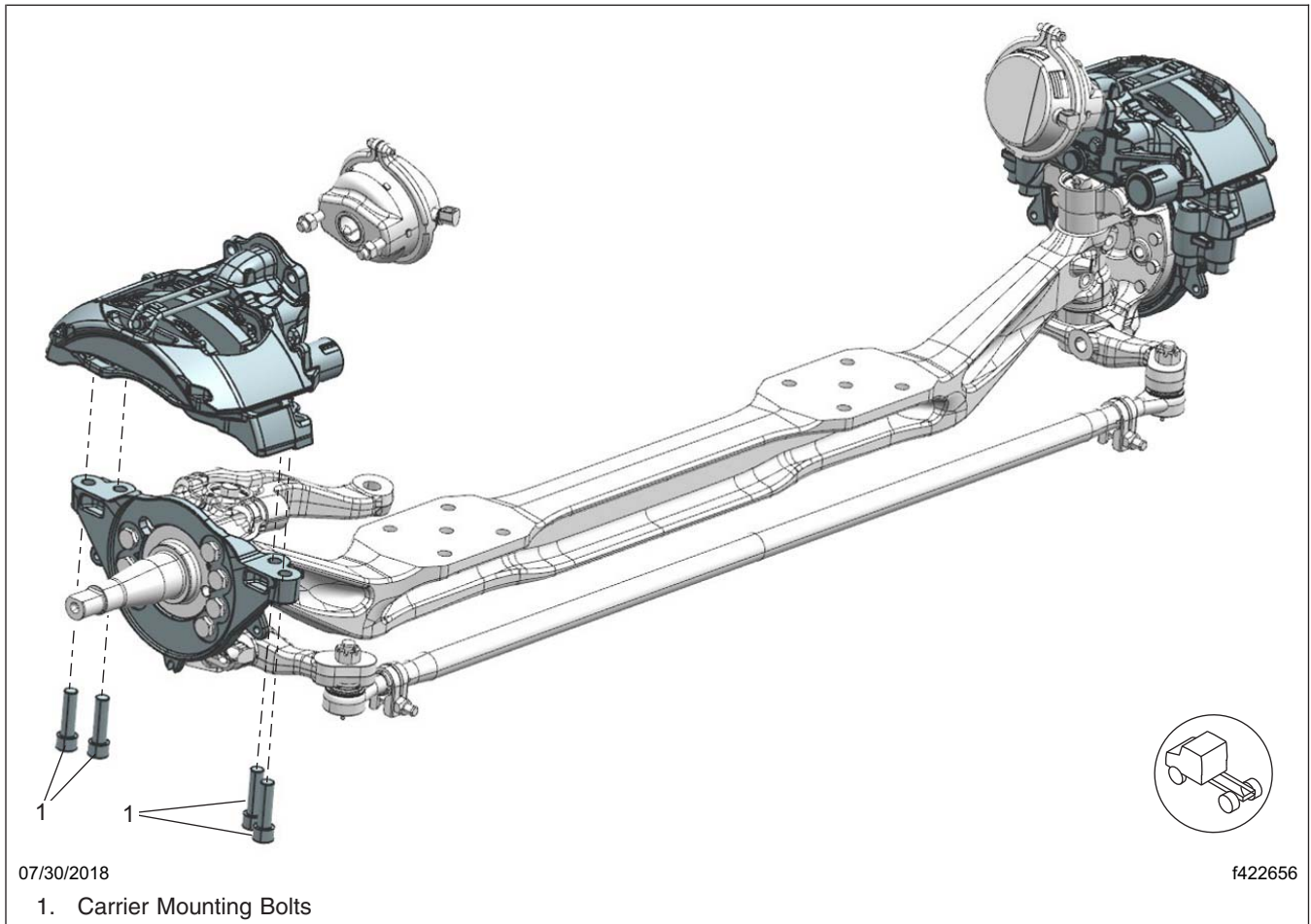

Fig. 7, Wabco Maxxus Radial Mounted Calipers

January 2019  
FL783A-M  
NHTSA #18V-525  
Transport Canada #2018-418  
REVISED NOTICE

NOTE: The tightening pattern will always start on the short (floating) pin side, with the bolt that passes through the shear sleeve.

6. Tighten the carrier mounting bolts in two steps, using the pattern shown in **Fig. 8**.
  - 6.1 Initially tighten all bolts  $45\pm 5$  lbf-ft ( $61\pm 7$  N·m). Slide the caliper inboard and outboard, through the center of the chamber or brake. The caliper must have a minimum of 20 mm of travel. If the brake assembly does not move, or requires more than 40 pounds of force to move, the caliper has a binding issue. File a WSC ticket for instructions.
  - 6.2 Perform a final tightening spec of  $295\pm 22$  lbf-ft ( $400\pm 30$  N·m). Slide the caliper inboard and outboard, through the center of the chamber or brake. The caliper must have a minimum of 20 mm of travel. If the brake assembly does not move, or requires more than 40 pounds of force to move, the caliper has a binding issue. File a WSC ticket for instructions.

## NOTICE

Do not use a motor driven tool to tighten the manual brake adjuster nut, or use excessive force to tighten the nut. Doing so could damage the manual brake adjuster nut.

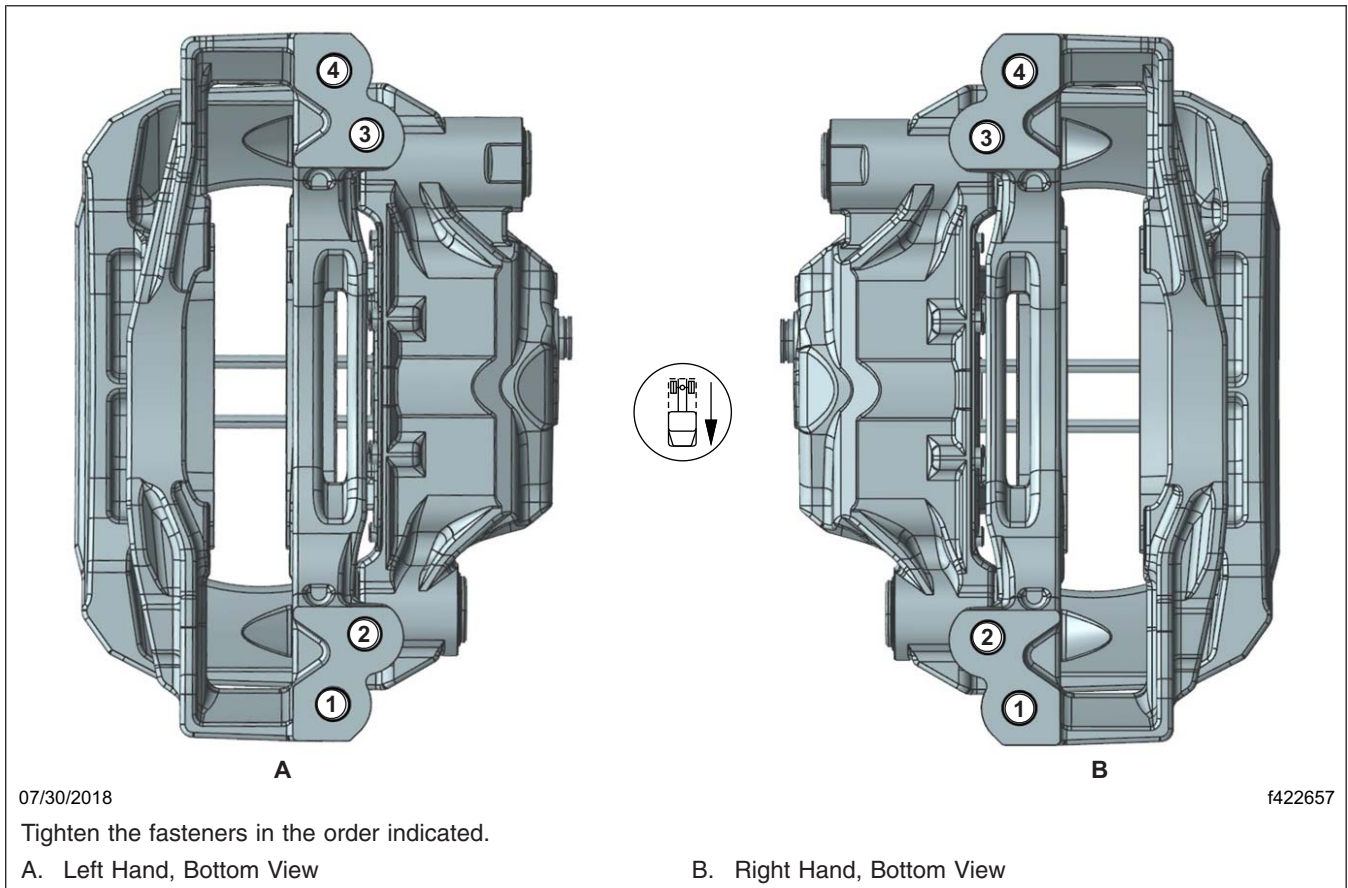

**Fig. 8, Wabco Maxxus Radial Mounted Caliper Tightening Pattern**

January 2019  
FL783A-M  
NHTSA #18V-525  
Transport Canada #2018-418  
**REVISED NOTICE**

7. Install the brake pads. Provided it is good condition, use the brake pad hardware removed earlier.
8. Back off the adjuster nut three clicks.
9. Install the wheel assemblies.
10. Raise the vehicle, remove the jack stands, then lower the vehicle.
11. Charge the air system and check for leaks.

 **WARNING**

**Do not operate the vehicle until the brakes have been adjusted and checked for proper operation. To do so could result in inadequate or no braking ability, which could cause personal injury or death, and property damage.**

12. In a safe area, check for proper brake operation, as follows, before putting the vehicle in service.
  - 12.1 Apply and release the brakes several times to check for air leaks and proper operation.
  - 12.2 Perform six low-speed stops to ensure proper parts replacement and full vehicle control.
  - 12.3 Immediately after doing the above stops, check the rotor temperatures. Any rotors that are significantly cooler than others indicate a lack of braking effort on those wheels.
13. Clean a spot on the base label (Form WAR259). Write the recall number, FL783, on a completion sticker (Form WAR260), and attach it to the base label to indicate this recall has been completed.