

March 5, 2019

Version 7

Product Update: 2017-18 CR-V: Software and A/C Control Unit Update, DTC P0300, P0301, P0302, P0303, P0304, or P0172Supersedes 18-114, dated February 1, 2019, to revise the information highlighted in **yellow****REVISION SUMMARY**

- Under **BACKGROUND**, information was updated
- Under **SOFTWARE INFORMATION**, information was updated
- Under **REPAIR PROCEDURE**, information was updated.

AFFECTED VEHICLES

Year	Model	Trim	VIN Range
2017-18	CR-V	EX, EX-L, Touring	Check the iN VIN status for eligibility.

BACKGROUND

Under certain circumstances, the vehicle may experience driveability issues, which may result in DTCs P0300 (random misfire detected), P0301 (No. 1 cylinder misfire detected), P0302 (No. 2 cylinder misfire detected), P0303 (No. 3 cylinder misfire detected), P0304 (No. 4 cylinder misfire detected), or P0172 (fuel system too rich) to set.

There are one of two updates that can be done. Check the iN VIN status inquiry for applicability.

- 18-114, *Product Update: 2017-18 CR-V Software and A/C Control Unit Update, DTC P0300, P0301, P0302, P0303, P0304, or P0172*
- OR
- 18-124, *Product Update: 2017-18 CR-V Software Update, DTC P0300, P0301, P0302, P0303, P0304, or P0172*

NOTE

If an affected vehicle is brought in for repair or is in your inventory and your dealership is located outside of the cold weather states listed below, repair the vehicle using S/B 19-026 *2017-18 CR-V: Software Update with A/C Control Unit Replacement; DTC P0300, P0301, P0302, P0303, P0304, or P0172*.

For this product update, American Honda has identified vehicles located or registered in the following cold-weather states as being affected: Alaska, Connecticut, Iowa, Illinois, Indiana, Massachusetts, Maine, Michigan, Minnesota, Montana, North Dakota, Nebraska, New Hampshire, New Jersey, New York, Ohio, Pennsylvania, Rhode Island, South Dakota, Vermont, Wisconsin

CUSTOMER INFORMATION: The information in this bulletin is intended for use only by skilled technicians who have the proper tools, equipment, and training to correctly and safely maintain your vehicle. These procedures should not be attempted by "do-it-yourselfers," and you should not assume this bulletin applies to your vehicle, or that your vehicle has the condition described. To determine whether this information applies, contact an authorized Honda automobile dealer.

CUSTOMER NOTIFICATION

Owners of affected vehicles will be sent a notification of this campaign.

Do an iN VIN status inquiry to make sure the vehicle is shown as eligible.

Some vehicles affected by this campaign may be in your new or used vehicle inventory. Repair these vehicles before they are sold.

CORRECTIVE ACTION

Reset the maintenance minder and replace only the engine oil without replacing the oil filter. Clear any DTC's and update the PGM-FI, TCM, and A/C control unit software to the latest version. Reset the throttle position learned values and do the PCM idle learn procedure.

WARRANTY CLAIM INFORMATION

If you did Service Bulletin 18-114 prior to February 1st, 2019, use the Warranty Claim Information provided on page 3 that is shaded in grey.

Use the warranty information below **only if dealerships is a participant of the bulk oil program.**

Operation Number	Description	Flat Rate Time	Defect Code	Symptom Code	Template ID	Failed Part Number
1245B1	Reset the maintenance minder. Update PGM-FI, TCM, and A/C control unit software. Replace the engine oil, and perform the throttle position reset and the PCM idle learn procedure.	0.7 hr	6DU00	V2Y00	A18114C	37805-5PA-A68

If your dealerships is not a participant of the bulk oil program, use the warranty information below.

Operation Number	Description	Flat Rate Time	Defect Code	Symptom Code	Template ID	Failed Part Number
1245B1	Reset the maintenance minder. Update PGM-FI, TCM, and A/C control unit software. Replace the engine oil, and perform the throttle position reset and the PCM idle learn procedure.	0.7 hr	6DU00	V2Y00	A18114D	37805-5PA-A68

If you did Service Bulletin 18-114 prior to February 1st, 2019, use the Warranty Claim Information provided below that is shaded in grey.

Use the warranty information below **only if dealerships is a participant of the bulk oil program.**

Operation Number	Description	Flat Rate Time	Defect Code	Symptom Code	Template ID	Failed Part Number
1245A2	Reset the maintenance minder light. Update PGM-FI and TCU software. Replace the engine oil, the A/C control unit, and perform the throttle position reset and PCM idle learn procedure.	0.8 hr	6DU00	V2Y00	A18114A	37805-5PA-A68

If your dealerships is not a participant of the bulk oil program, use the warranty information below.

Operation Number	Description	Flat Rate Time	Defect Code	Symptom Code	Template ID	Failed Part Number
1245A2	Reset the maintenance minder light. Update PGM-FI and TCU software. Replace the engine oil, the A/C control unit, and perform the throttle position reset and PCM idle learn procedure.	0.8 hr	6DU00	V2Y00	A18114B	37805-5PA-A68

For your reference, below is the part that was needed to complete the old repair procedure:

- A/C Control Unit, **79600-TLA-A62**

PARTS INFORMATION

Part Name	Part Number	Quantity
Drain Plug Washer (14 mm)	94109-14000	1

TOOL INFORMATION

Part Name	Part Number	Quantity
A/C Control Unit Reflash Kit	070AL-TBAA100	1

NOTE

The box that the tool will arrive in has a part number of **070AL-TBAA1Z0**. This box will contain two A/C Control Unit Reflash Kits and two spare A/C Reflash Sub Cables (P/N **07AAJ-TBAA110**) to be used for this campaign.

MATERIAL INFORMATION

Part Name	Part Number	Quantity
0W-20 (Bulk Oil Participants) (Gallons)	FS020-BAS-N0L	1
0W-20 (Non-Bulk Oil Participants) (Quarts)	08798-9063	4
A/C Reflash Sub Cable	07AAJ-TBAA110	1 (One sub cable will repair about 50 vehicles)

NOTE

The A/C Reflash Sub Cable is listed under MATERIAL INFORMATION section so that dealers can receive the correct reimbursement for each repair. Each repair can be reimbursed for 1/50th of the price of a replacement sub cable. Dealers deciding not to use a template to file claims can be reimbursed for the sub cable by selecting "OTHERS" in the Material Type drop-down, enter the part number (P/N **07AAJ-TBAA110**), a quantity of one, and \$0.24 in the unit price field. If you are experiencing issues stated in the REPAIR PROCEDURE, order a new sub cable through the parts system, which will be good for about 50 uses.

SOFTWARE INFORMATION

NOTE

Unnecessary or incorrect repairs resulting from a failure to update the i-HDS are not covered under warranty.

i-HDS Software Version: **1.004.064 or later**

J2534 Software Information:

- PC Application Version **1.1.0.6 or later**
- Database update **27-DEC-2018 or later**

Before beginning the repair, make sure that both the i-HDS and J2534 software are updated as listed above.

For more information about updating the i-HDS, the MVCI, and vehicle systems, refer to Service Bulletin 01-023, *Updating Control Units/Modules*.

Year/Model	Software System	Program ID (or later)	Program P/N (or later)
2017 CR-V (2WD)	PGM-FI	PA3060	37805-5PA-306
2017 CR-V (AWD)	PGM-FI	PA3080	37805-5PA-308
2018 CR-V (2WD)	PGM-FI	PAA690	37805-5PA-A69
2018 CR-V (AWD)	PGM-FI	PAA890	37805-5PA-A89
2017-18 CR-V (2WD)	TCM	RHA040	28101-5RH-A04
2017-18 CR-V (AWD)	TCM	RGA040	28101-5RG-A04

REPAIR PROCEDURE

1. Reset maintenance minder main code A. Refer to the service information.
2. Drain and refill the engine oil. Do not replace the oil filter. (3.4 quarts)
3. Connect a fully charged jumper battery to the vehicle and leave it connected during the entire procedure to maintain steady voltage.
4. Connect the i-HDS and click on the **Body Electrical**. From there, select **HVAC** and open **Data List/Snapshot** to check if the A/C control unit has been updated. One of three options will appear; **Not Complete**, **Completed**, or **Not Applicable**.
 - If it reads **Completed** or **Not Applicable**, skip to step 6.
 - If it reads **Not Complete**, go to step 5.
5. Update the A/C control unit.

NOTE

Make sure that both the power switch and ignition are **OFF** before you continue.

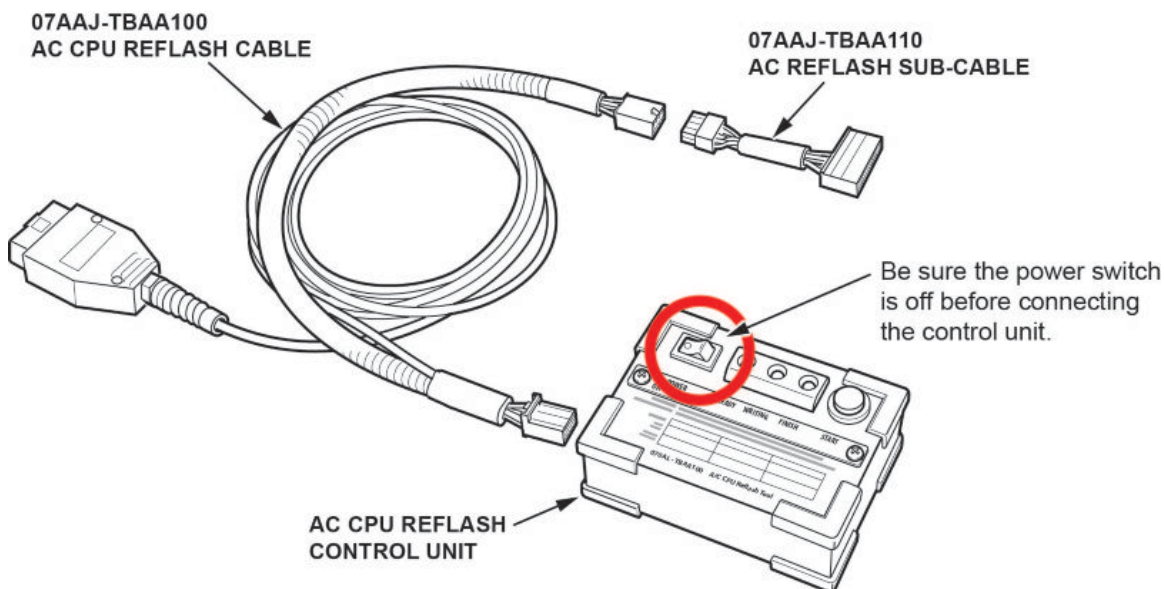

- 5.1. Remove the passenger's dashboard undercover. This will expose the A/C control unit on the right-hand side.

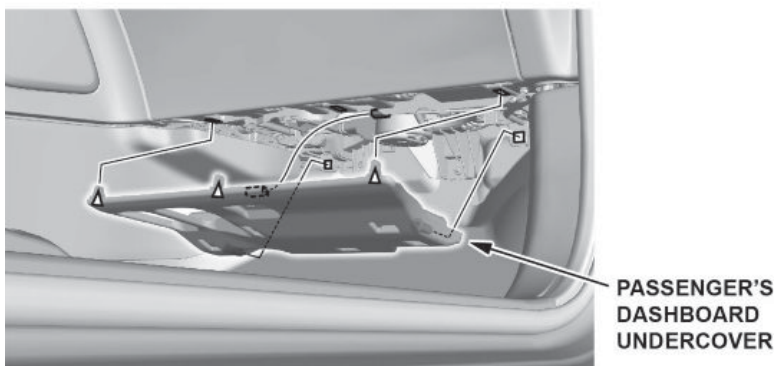

5.2. Disconnect the 32 pin connector from the A/C control unit and plug in the sub cable.

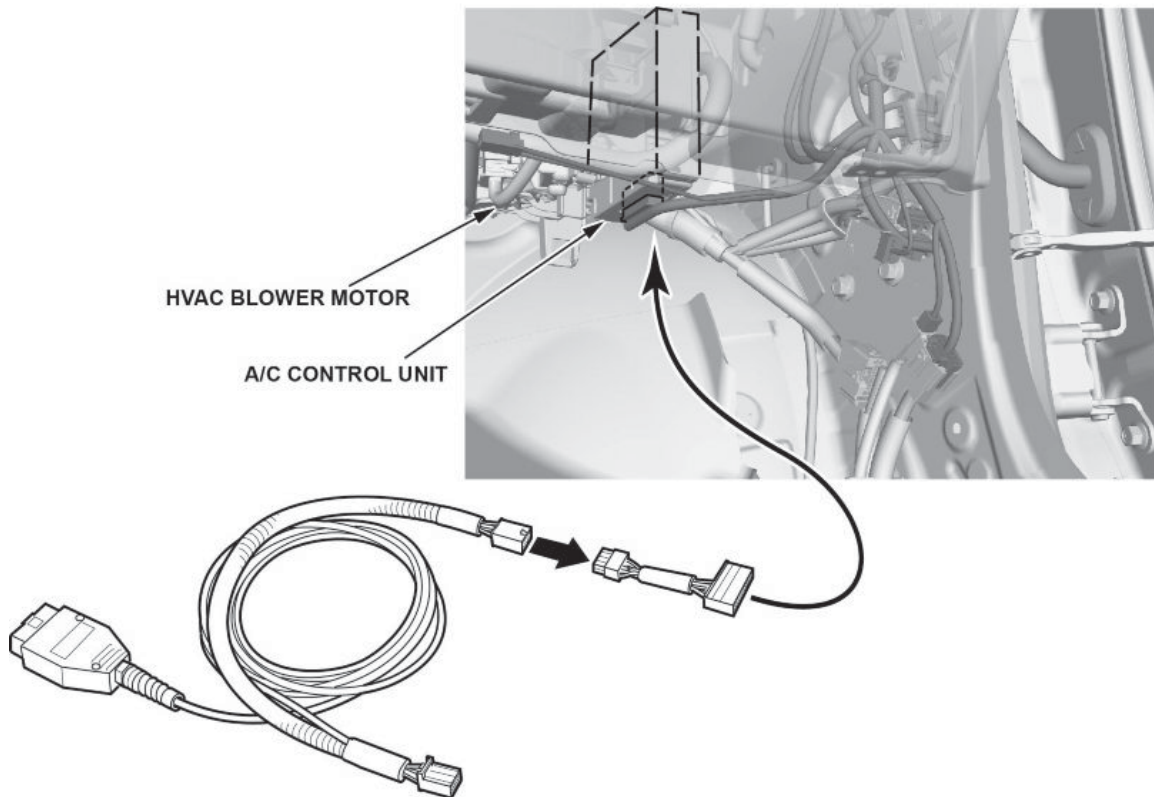

5.3. Plug the A/C reflash sub cable to the A/C CPU reflash cable.

5.4. Plug the A/C CPU reflash cable to the tool.

5.5. Connect the A/C CPU reflash cable to the OBD2 connector to supply power to the tool.

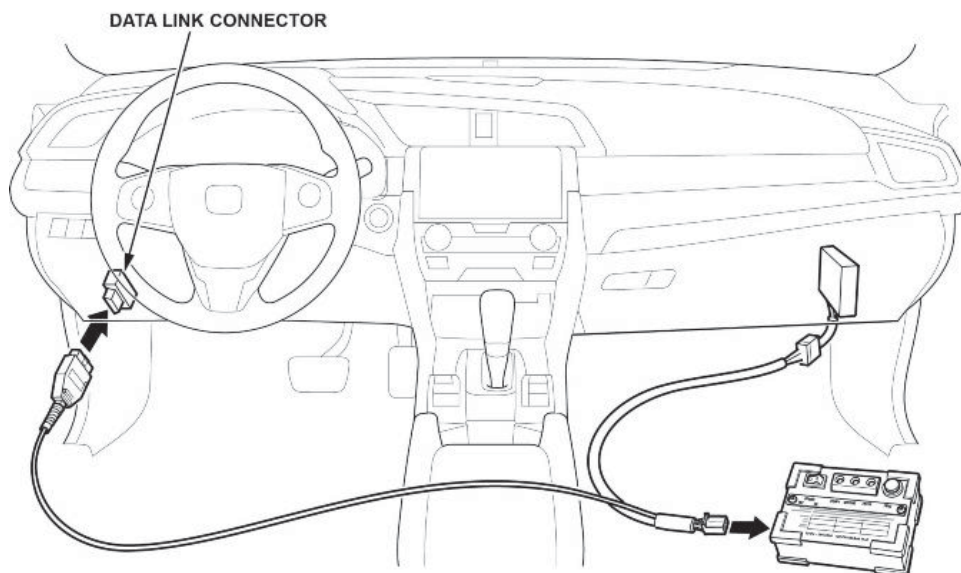

- 5.6. Turn the power switch to **ON**. A solid green LED should come on.

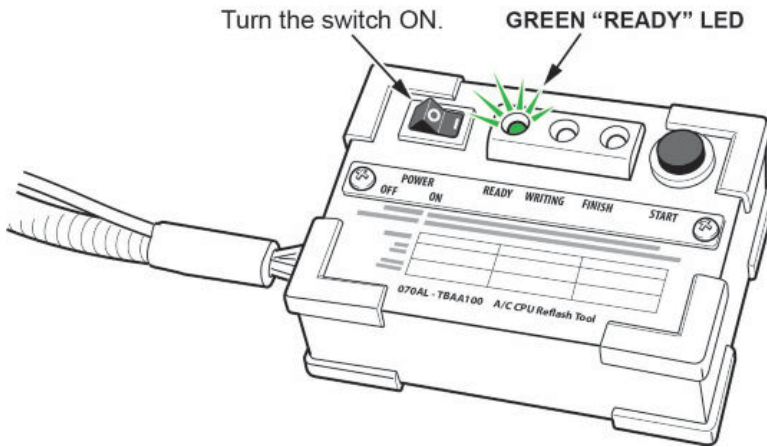

NOTE

If the green LED starts flashing, there might be an issue with the tool. Use a different or known good cable or tool as needed and try again.

- 5.7. Once the solid green LED is on, press the black "start" button on the right-hand side to start the rewriting process.
- 5.8. A solid yellow LED should appear, which means that the tool is rewriting the A/C control unit.

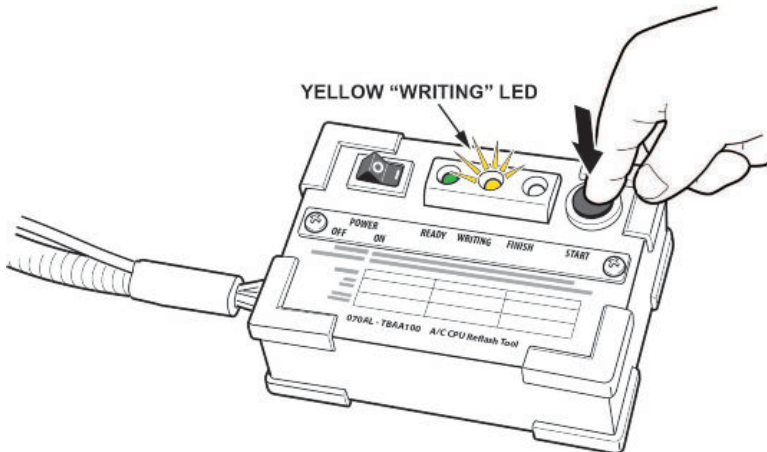

NOTE

If the yellow LED is flashing, the vehicle may have been updated previously or is ineligible for the update, or the sub cable is worn out. If the sub cable is worn out, replace it and try again. The 32 pin connector on the sub cable is expected to last about 50 connections. **If the yellow LED is still flashing after replacement of the sub cable, refer to S/B 19-026, 2017-18 CR-V: Software Update with A/C Control Unit Replacement; DTC P0300, P0301, P0302, P0303, P0304, or P0172 for further instructions.**

5.9. Once complete, a solid blue LED should come on, which means the procedure is complete.

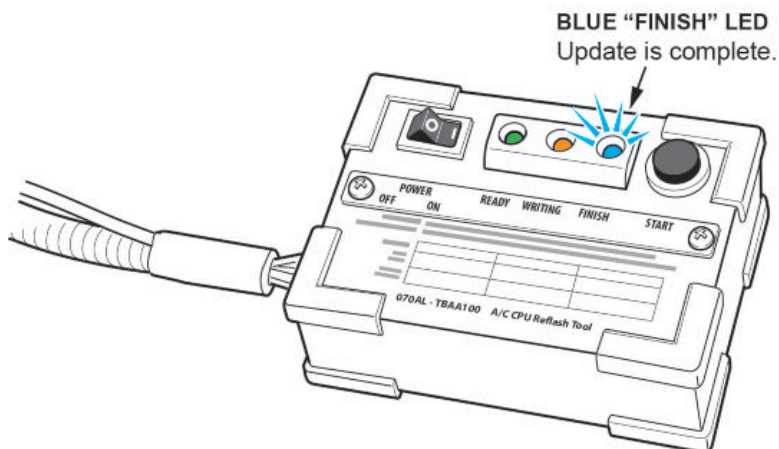

NOTE

If the blue LED is flashing, the update has failed. Power off the tool and repeat the procedure again. If the error is consistent, replace the sub cable and try again. The 32 pin connector on the sub cable is expected to last about 50 connections.

5.10. Turn the tool **OFF**, connect the factory harness to the A/C control unit, and install the passenger's dashboard undercover.

NOTE

If you have questions or concerns with the tool, please call Special Tools Hotline at (800) 346-6327.

6. Update the PGM-FI and TCM software using the i-HDS J2534 rewrite software with the MVCI or DST-i. Refer to Service Bulletin 01-023, *Updating Control Units/Modules*.

NOTES

- Never turn the ignition to OFF or ACCESSORY during the update. If there is a problem with the update, leave the ignition turned to ON.
 - To prevent control unit damage, do not operate anything electrical (headlights, audio system, brakes, A/C, power windows, door locks, etc.) during the update.
 - Do not use the MongoosePro VCI tool.
7. Reset the throttle position learned values by referencing the throttle body removal and installation in the service information, then do the PCM idle learn procedure. Refer to service information for additional instructions.

NOTE

More information on this procedure can be found in the Tech2Tech video titled, *A Look at PCM Idle Learn*.

END